



Light Commercial Vehicles

Leichte Nutzfahrzeuge

Véhicules utilitaires légers

Vehículos comerciales ligeros

Veicoli commerciali leggeri

Samochody dostawcze

































Легкий коммерческий транспорт



2020/2021

SCHAEFFLER

Part groups

	Axle journal, axle beam
	Axial joint, tie rod
	Torsion bar set
	Torsion bar
	Steering gaiter set
	Strut mount
	Adjustable coupling sleeve set
	Master and slave cylinder set
	Master cylinder
	CV joint kit
	Overrunning alternator pulley
	Encoder, crankshaft
	V-belt
	Multi-ribbed belt
	Multi-ribbed belt set
	Oil pump drive chain
	Timing chain kit for oil pump drive
	LuK RepSet
	LuK RepSet with Concentric Slave Cylinder (CSC)
	Bearing journal, tensioner pulley lever
	Track control arm
	Ball joint kit
	Axle journal kit
	Slave cylinder
	Camshaft
	Camshaft kit
	Variable camshaft phaser
	Wheel bearing
	Wheel bearing kit
	WheelPro – contains 2x wheel bearing kits
	Axle beam repair kit
	Axle journal repair kit
	Strut mount repair kit

Leichte Nutzfahrzeuge: ein Wachstumsmarkt	4
Produkthighlights von Schaeffler im Automotive Aftermarket	6
Artikelgruppen	12
Seitenaufbau	13
Informationen zur Artikelverwendung	14

CITROËN	114
BERLINGO	114
JUMPER	127
FIAT	139
DOBLO	139
DUCATO	151
FIORINO	176
SCUDO	178
TALENTO	182
FORD	183
TRANSIT	183
FUSO (MITSUBISHI)	216
CANTER	216
GAZ	216
GAZELLE	216
HYUNDAI	217
H-1	217
H200	221
IVECO	222
DAILY	222

MAN	289
TGE	289
MERCEDES-BENZ	290
SPRINTER	290
VITO	357
MITSUBISHI	375
CANTER	375
L200	376
L300	376
NISSAN	376
CABSTAR	376
INTERSTAR	377
NT400	386
NV200	386
NV300	388
NV400	390
PRIMASTAR	401
OPEL	410
COMBO	410
MOVANO	418

VIVARO	444
PEUGEOT	463
BOXER	463
EXPERT	474
PARTNER	481
RENAULT	495
KANGOO	495
MASTER	508
TRAFIC	543
TOYOTA	563
HIACE	563
VAUXHALL	569
COMBO	569
MOVANO	576
VIVARO	597
VW	615
CADDY	615
CRAFTER	635
LT	641
TRANSPORTER	642



Content ... 19



Contenu ... 35



Índice ... 51



Indice ... 67



Spis treści ... 83



Содержание ... 99

Numerische Liste	678
------------------	-----

Nachdruck, auch auszugsweise, nur mit unserer Genehmigung.
Ersatzansprüche aufgrund von Angaben in diesem Katalog sind ausgeschlossen. Sofern auf die Ersatzteilnummern der

Fahrzeughersteller Bezug genommen wird, dient dies nur zu Vergleichszwecken.

Eine Verwendung derartiger Angaben in Rechnungen an den Fahrzeugbesitzer ist nicht statthaft.

Leichte Nutzfahrzeuge: ein Wachstumsmarkt

Branche mit Aufwind

Schon heute sind leichte Nutzfahrzeuge nicht mehr aus unserem Alltag wegzudenken. Transporter aller Art sind gefragt wie nie. Mit einem prognostizierten Marktwachstum von acht Prozent jährlich sind sie das am stärksten wachsende Fahrzeugsegment und das Rückgrat des gewerblich genutzten Transportgeschäftes. Tendenz stark steigend, denn die Beliebtheit des Onlinehandels nimmt rasant zu und schnellere Lieferungen bis vor die Haustür sind gefragt wie nie.

Auf diesem Abschnitt vom letzten Verteilzentrum bis zum Verbraucher, auch „last mile“ genannt, findet das größte Wachstum im so genannten KEP-Markt (Kurier, Express und Paket) statt: Prognosen zufolge wird sich die Paketgröße verkleinern, die Paketanzahl mehr als verdoppeln und Express-Lieferungen am selben Tag werden Realität. Als Effekt steigt die Nachfrage nach Transportern zur gewerblichen Nutzung, die schnell und wendig ihre Lieferungen zustellen können. Ein wichtiges Kriterium insbesondere für Stadtgebiete, denn bereits im Jahr 2025 wird ein Viertel der gesamten Weltbevölkerung in den 600 größten Städten leben und mehr als die Hälfte der weltweiten Wirtschaftsleistung generieren.

Potenziale erkennen

Das boomende Transporter-Geschäft birgt ein enormes Potenzial für freie Werkstätten und eröffnet neue Geschäftsmodelle. Denn: Transportfahrzeuge müssen im Stadtverkehr schnell und flexibel sein, hohe Laufleistungen erbringen, schwere Ladungen transportieren und teilweise unter härtesten Bedingungen einwandfrei funktionieren. Es sind Paketdienstleister, Kurierfahrer, Handwerksbetriebe und Einzelhändler, deren Fahrzeuge pro Tag bis zu 120 Stopps anfahren. Auch Laufleistungen von über 100.000 Kilometer im Jahr sind

keine Seltenheit – und das unter ständigem Termindruck. Da bleibt ein hoher Verschleiß und Reparaturaufwand nicht aus.

Freie Werkstätten können an diesem stetig wachsenden Markt partizipieren, indem sie ihren bisherigen Kundstamm um gewerbliche Kunden erweitern und neue Serviceleistungen für Transporter anbieten. Für die schnelle und einfache Reparatur von leichten Nutzfahrzeugen bietet die Schaeffler-Sparte Automotive Aftermarket Reparaturlösungen für Antrieb, Motor und Fahrwerk, die sich durch einen unkomplizierten und schnellen Einbau auszeichnen, wodurch Standzeiten verkürzt werden.

Der Verkauf von zusätzlichen Werkstattdienstleistungen und Ersatzteilen schafft mehr Auslastung in der Werkstatt und bietet gute Voraussetzungen, um sich als Transporter-Spezialist zu positionieren: Während die Modellvielfalt im Pkw-Bereich sehr groß ist, können mit den gängigen Transportern, wie dem Ford Transit, Mercedes-Benz Sprinter, Fiat Ducato und VW Transporter, der Großteil des Marktes abgedeckt werden. Dabei ist der Ford Transit das mit Abstand beliebteste Modell bei den leichten Nutzfahrzeugen. Jedes zehnte Fahrzeug in Europa 37 ist ein Transit, gefolgt von Mercedes-Benz Sprinter und VW Transporter.

Insbesondere für Lkw-Werkstätten ergeben sich neue Geschäftsmöglichkeiten unter bekannten Rahmenbedingungen: Für Gewerbekunden zählen eine schnelle und verlässliche Reparatur, um das Fahrzeug zügig wieder einsetzen zu können. Stillstand ist teuer. Bis zu 1.000 Euro kann ein Ausfalltag den Fahrzeugbetreiber kosten. Somit werden die Betriebskosten zum dominierenden Wettbewerbsvorteil in einer Branche, die geprägt ist durch Zeit- und Kostendruck.



Die Transportbranche boomt. Das starke Wachstum des Onlinehandels befeuert Kurier-Express- und Paket-Dienstleistungen und somit auch die Nachfrage nach leichten Nutzfahrzeugen.



Der Marktanteil und das Marktwachstum der Transporter ist so hoch, dass es für jede Nkw-Werkstatt eine Überlegung wert ist, diesen Servicebereich in das Werkstattportfolio aufzunehmen und aktiv zu vermarkten.

Markenübergreifendes Portfolio für gewerblich genutzte Fahrzeuge

Rund um die Uhr, sieben Tage die Woche: Gewerblich genutzte Fahrzeuge wie Kastenwagen, Kipper, Pritsche oder Bus verlangen täglich ein Höchstmaß an Betriebsbereitschaft unter härtesten Bedingungen. Dabei unterliegen sie einem höheren Verschleiß und müssen häufiger repariert werden als Pkw.

Genau hier setzt Schaeffler mit seinen einfach und schnell einzubauenden Reparaturlösungen an. Neben den Reparaturkosten sind im Business-to-Business-Umfeld vor allem die reparaturbedingten Ausfallzeiten entscheidend. Je einbaufreundlicher die Reparaturlösung, desto schneller ist das Fahrzeug wieder auf der Straße. Qualitativ hochwertige Produkte mit einer hohen Lebensdauer sorgen zudem für verlängerte Serviceintervalle. Diese speziellen Anforderungen hat Schaeffler im Automotive Aftermarket erkannt und richtet sein Portfolio über alle vier Marken – LuK, INA, FAG und Ruville – hinweg, künftig noch stärker auf die Kundenbedürfnisse von Transportunternehmen und Flottenbetreibern aus. Das Sortiment umfasst Komponenten und Reparaturlösungen für Antrieb, Motor und Fahrwerk – in höchster Qualität, alles aus einer Hand.

Alle Produkte für leichte Nutzfahrzeuge werden mit dem Ziel entwickelt, die Mobilität zu erhöhen und die Betriebskosten zu reduzieren. Im Fokus stehen langlebige und kostenoptimierende Reparaturlösungen und ein markenübergreifendes Portfolio für die wichtigsten Fahrzeuge wie den Ford Transit und den Mercedes-Benz Sprinter zu etablieren und auszubauen. Davon profitieren Fuhrparkmanager, Fahrzeugbetreiber, Werkstätten, aber auch der Teilehandel gleichermaßen.

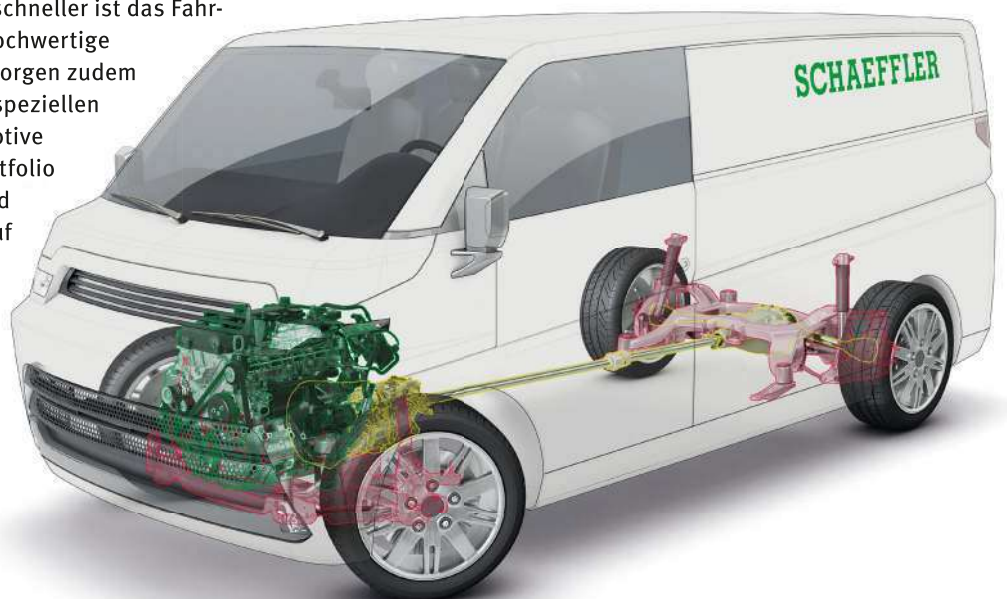

Alles aus einer Hand – Reparaturlösungen für Antrieb, Motor und Fahrwerk.

Produkthighlights von Schaeffler im Automotive Aftermarket

Impact Torque Limiter

Längere Lebensdauer dank Überlastschutz

Leichte Nutzfahrzeuge unterliegen extremen Belastungen: maximale Beladung bis an die Grenze des zulässigen Gesamtgewichts, ein besonders langer und damit empfindlicher Antriebstrang bei Hecktrieblern sowie ein Fahrverhalten, das geprägt ist vom immensen Kosten- und Zeitdruck in der Transportbranche. Häufiger Fahrertausch und Stop-and-go sind bei leichten Nutzfahrzeugen nicht untypisch und erhöhen die Beanspruchung.

Um den Antriebstrang vor Überlastung und somit vor vorzeitigem Ausfall des Fahrzeugs zu schützen, entwickelte Schaeffler einen Mechanismus zur Begrenzung von Spitzenmomenten im Antriebstrang: Den so genannten Impact Torque Limiter – eine Sonderausstattung des Zweimassenschwungrads (ZMS).

Beim Versuch, die Motordrehzahl besonders schnell an die Drehzahl der Getriebeeingangswelle anzupassen, entstehen schlagartige Spitzenbelastungen mit kurzzeitigen Drehmomentwerten, die um ein vielfaches höher sind als das maximale Motordrehmoment.

Solche „Impacts“ können auf Dauer das ZMS schädigen und sich negativ auf Motor und Antriebstrang auswirken. Bei leichten Nutzfahrzeugen sind diese Drehmomentspitzen im vollen Beladungszustand nochmals höher.

Der Impact Torque Limiter ermöglicht ein kurzzeitiges Durchrutschen des Flansches, wodurch die schlagartigen Spitzenbelastungen im Antriebsstrang abgebaut werden.

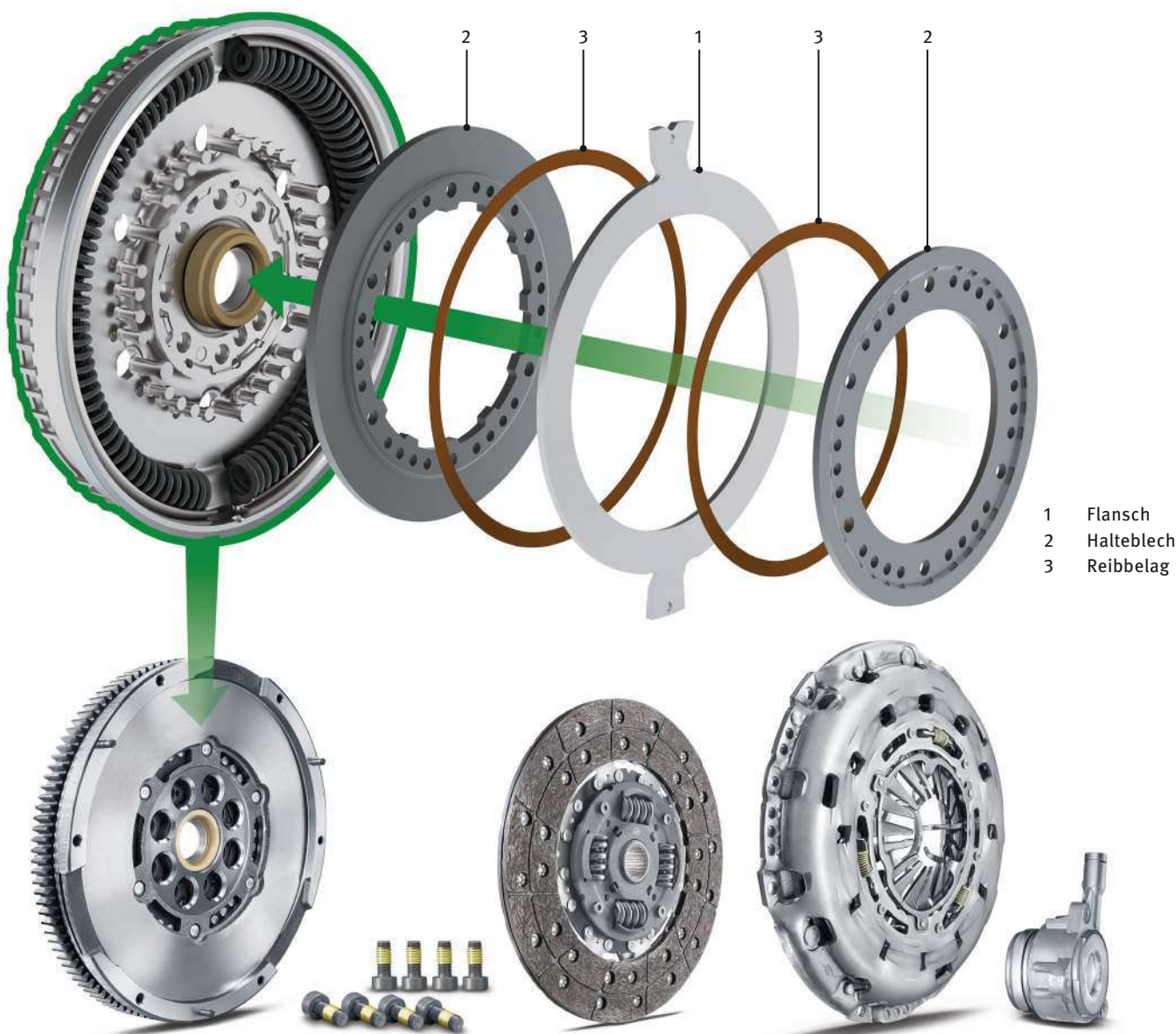

Schaeffler bietet das impactsichere Zweimassenschwungrad speziell im Segment leichte Nutzfahrzeuge an, zum Beispiel für den Ford Transit und IVECO Daily, und ist hier der einzige Anbieter im Markt.



Flottenbetreiber im Fokus: Da fehlt absolut nichts – LuK GearBOX

Unsere kostenoptimierende Lösung lautet hier: LuK GearBOX

Jeder Getriebetyp – gleich welchen Herstellers – weist ein individuelles Verschleißverhalten auf. Bei leichten Nutzfahrzeugen, bei denen Laufleistungen von über 100.000 Kilometern im Jahr keine Seltenheit sind, tritt der Verschleiß entsprechend früher ein. Hohe Beladung und häufig wechselndes Fahrverhalten belasten das Getriebe zusätzlich. In der Regel beginnt es mit einem Lagerschaden, der sich durch ein rauschendes oder schleifendes Geräusch im Getriebe bemerkbar macht. Ohne geeignete Gegenmaßnahmen droht der teure Ausfall des Nutzfahrzeugs.

Das Konzept der LuK GearBOX basiert auf intensiver Analyse der Hauptausfallgründe von manuellen Schaltgetrieben. Die Reparaturlösung umfasst individuelle Komponenten zur Beseitigung spezieller Ausfallursachen.

Ergänzt wird die LuK GearBOX durch Hauptlager, Dichtelemente und weitere Verschleißteile, die im Rahmen einer fachgerechten Reparatur ersetzt werden sollten, da sie im Betrieb hohen Beanspruchungen unterliegen. Spezialwerkzeuge für einen einfachen Reparaturablauf runden das Angebot ab.



Die LuK GearBOX beinhaltet individuelle Komponenten zur Beseitigung spezieller Ausfallursachen, inklusive Hauptlager, Dichtelemente und Verschleißteile.

Motor und Nebenaggregatetrieb

Nachhaltig und perfekt verzahnt für ihren Erfolg

Täglich bis zu 120 Start-Stopp-Vorgänge, ständig schwankende Drehzahlen im Stadtverkehr, lange Leerlaufphasen, z. B. an Ampeln oder parkend in zweiter Reihe, führen zu extremen Vibrationen. Die Motoren leichter Nutzfahrzeuge sind ständiger Belastung ausgesetzt, die letztlich zu erhöhtem Verschleiß führen. Hinzu kommen Laufleistungen von bis zu zehn Stunden am Tag und zum Teil über 100.000 Kilometer im Jahr. In Europa sind außerdem gut 85 Prozent aller leichten Nutzfahrzeuge mit einem Dieselmotor ausgestattet, einem trotz vieler Vorteile zumindest in Sachen Vibration eher unruhigen System.

Trotz aller Widrigkeiten gilt: Gewerbliche Betreiber dieser Fahrzeuge können sich keinerlei Ausfälle leisten. Schaeffler bietet daher sowohl für den Steuertrieb als auch für den stets an Bedeutung wachsenden Nebenaggregatetrieb optimale Produktlösungen.

Schaeffler fokussiert mit seinem „Vehicle Solutions“-Ansatz immer das komplette Fahrzeug und hält mit seinen Marken LuK, INA und FAG für die gängigsten Modelle Lösungen für Antrieb, Motor und Fahrwerk bereit.

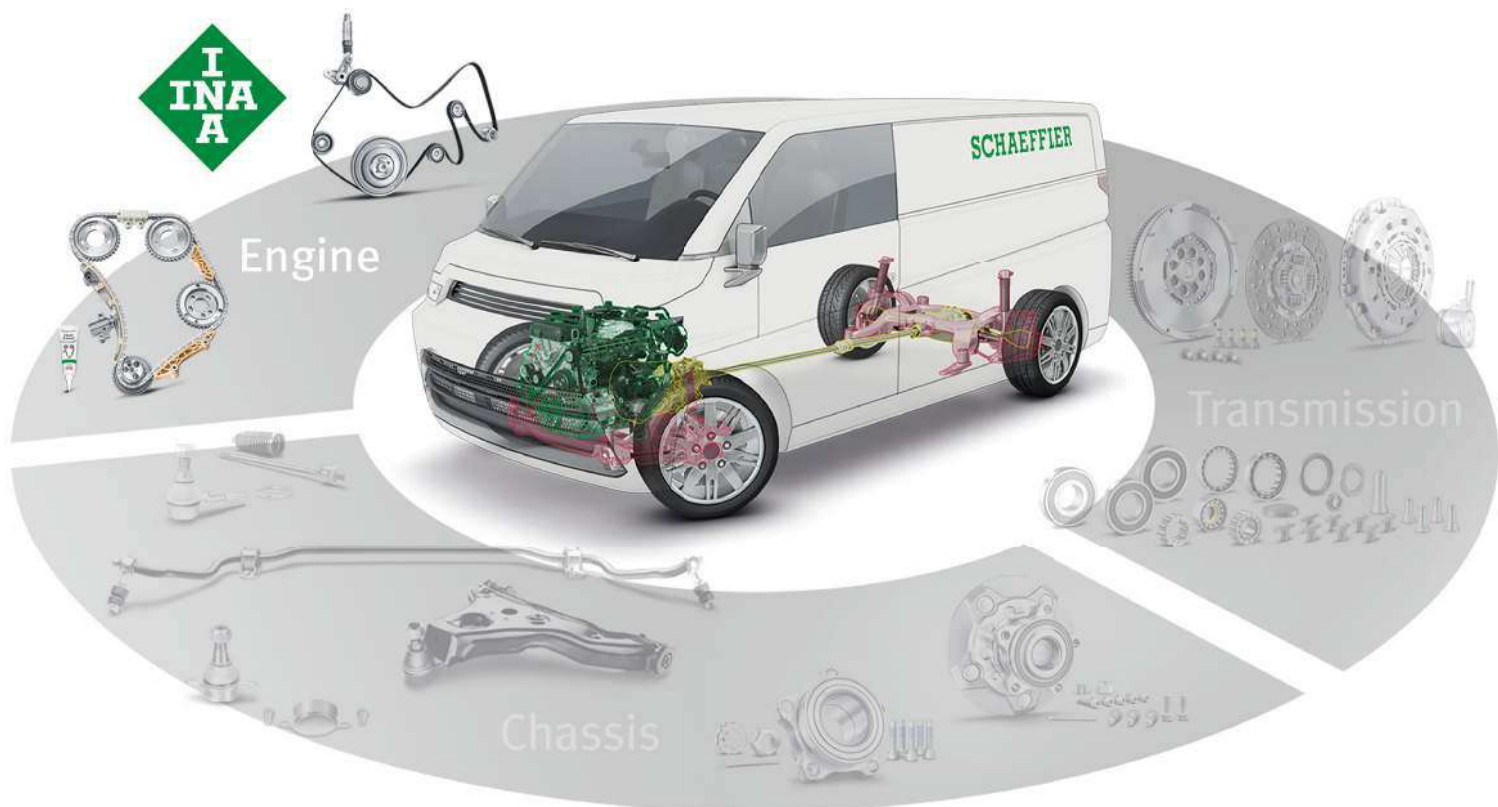

Mit den INA FEAD KIT bietet Schaeffler perfekt aufeinander abgestimmte Komplettlösungen für eine nachhaltige Reparatur des Nebenaggregatetriebs an. Zu seinen Hauptkomponenten gehören stets der Riemen, Spann- und Umlenkrollen sowie alle notwendigen Zubehörteile.

Bauteile im Steuertrieb sind einer extremen Belastung ausgesetzt. Ein Grund mehr, im Reparaturfall stets das komplette System auszutauschen. Schaeffler bietet mit seiner Marke INA ein umfangreiches Portfolio an Steuerketten-KIT-Lösungen.



Steuertrieb

Gut ein Drittel aller Top-Modelle im leichten Nutzfahrzeuge-Segment in Europa haben aktuell im Steuertrieb die Kette im Einsatz, Tendenz steigend. Präzision und Passgenauigkeit sind für den „Taktgeber“ des Motors unerlässlich. Da alle Teile perfekt miteinander harmonisieren müssen, bietet es sich zudem an stets das gesamte System auszutauschen. Alle Steuerketten-KIT-Lösungen sind individuell auf jeden Motor und jede Abwandlung des Motors eingestellt – millimetergenau. Die OE-Qualität ist hierbei durch die gemeinsame Entwicklung mit Schaeffler Engineering sichergestellt. Unser gemeinsam mit Liqui Moly entwickeltes Steuerketten-Additiv „Chain Protect“ garantiert darüber hinaus eine längere Lebensdauer des Steuertriebes.

Steuerketten-Kits (Beispiele):

- | | |
|---|---|
| <ul style="list-style-type: none"> • Ford Transit (2,0L, 2,2L, 2,4L)
Bj. bis 2006
und 2006–2014
559018730
559018830
559015230
559017630
559018930
559019330
559018430 | <ul style="list-style-type: none"> • Mercedes Benz Sprinter (T1N, NCV, VS30)
Bj. bis 2006
und 2006–2018
559003910
559004510
559004010
559005110
559004910
559005010
559004610 |
|---|---|



Nebenaggregatetrieb

Auch der Nebenaggregatetrieb wird bei leichten Nutzfahrzeugen immer bedeutsamer. Da das Fahrzeug oftmals als Arbeitsplatz fungiert, haben Komfort und Ausstattung der Fahrzeuge längst ein Niveau erreicht, das bislang nur Oberklassen-Pkw erreichten. Zwar bedeutet ein Ausfall des Systems nicht gleich einen Stillstand des Fahrzeugs, dennoch sind die durch den Nebenaggregatetrieb angetriebenen Komponenten mittlerweile unerlässlich – egal ob Generator, Klimakompressor oder Wasserpumpe. Sobald also am Motor etwas repariert wird, bietet sich ein Ausfall vorbeugender Wechsel der Baugruppe an.

Auch hier sind natürlich die starken Belastungen durch Vibrationen und der Dauereinsatz des Nutzfahrzeugs Grund für den Verschleiß. Schaeffler begegnet dieser Thematik mit einem auf diese Anforderungen ausgelegten Sortiment. So sorgen beispielsweise spezielle Fette, ausgelegt von tiefen

Temperaturen in den Wintermonaten, bis hin zu höchsten Anforderungen im Dauerbetrieb für eine zuverlässige Funktion. Widerstandsfähige Dichtungsmaterialien sowie kompromisslos sichergestellte Qualität der Ersatzteile garantieren eine langlebige und nachhaltige Reparatur.

Nebenaggregate-Kits (Beispiele):

- | | |
|---|---|
| <ul style="list-style-type: none"> • Ford Transit (2,0L, 2,2L, 2,4L)
Bj. bis 2006
und 2006–2014
529030110
529030130 (inkl. Wasserpumpe)
529036410
529036430 (inkl. Wasserpumpe)
529039010 | <ul style="list-style-type: none"> • Mercedes Benz Sprinter (T1N, NCV, VS30)
Bj. bis 2006
und 2006–2018
529014010
529013910
529033310
529005010
529036110 |
|---|---|





FAG Radlager Reparaturlösung für leichte Nutzfahrzeuge

Schnelle Reparatur des Radlagers

Optimalen Kundennutzen bietet die Radlager-Reparaturlösung von FAG für die Modelle Mercedes-Benz Sprinter, Viano, Vito und Volkswagen Crafter. Statt den kompletten Achsschenkel auszutauschen, entwickelte Schaeffler ein Spezialwerkzeug, mit dem der Achsschenkel bei der Radlagerreparatur am Fahrzeug verbleibt. Nur das Radlager wird getauscht und die sonst erforderliche Achsvermessung nach der Montage entfällt.

Dieses ausgeklügelte Reparaturverfahren spart Werkstätten mehrere Arbeitsschritte und reduziert die erforderliche Arbeitszeit gegenüber konventionellen Radlagerreparaturen um bis zu 60 Prozent.

Optimierte Reparaturverfahren dieser Art bedeuten für die freie Werkstatt neue Geschäftspotenziale: Flottenbetreiber und Transportunternehmen profitieren von minimierten Stillstandzeiten und einer höheren Einsatzzeit des Nutzfahrzeugs, was die Kundenbindung stärkt. Der bisherige Kundenstamm erweitert sich um Gewerbekunden und eröffnet die Verkaufsmöglichkeit von zusätzlichen Werkstattleistungen und Ersatzteilen.

FAG Radlagersätze

- 713 6680 10
Mercedes-Benz Sprinter/VW Crafter bis 1850 kg Achslast
- 713 6680 20
Mercedes-Benz Sprinter/VW Crafter ab 1850 kg Achslast
- 713 6680 50 Mercedes-Benz Vito und Viano



FAG Spezialwerkzeug

- 400 6199 10

Für die korrekte Demontage und Montage der FAG Radlagersätze ist das FAG Spezialwerkzeug unerlässlich.



Lenkungs- und Fahrwerksteile

Kompromisslose Qualität für die härtesten Anforderungen

Um den alltäglichen Herausforderungen im Transportgeschäft standhalten zu können, sind Lenkungs- und Fahrwerksteile von Schaeffler intelligent konzipiert und absolut zuverlässig. Jedes Produkt durchläuft einen besonders intensiven Prüfprozess, bevor es auf den Markt kommt. Im eigenen Schaeffler-Labor werden alle Bauteile hinsichtlich Dimension, Funktion und Werkstoffqualität auf den Prüfstand gestellt. Zusätzlich wird die Qualität der Bauteile durch Prüfungen unabhängiger Institute wie der Rheinisch-Westfälischen Technischen Hochschule (RWTH) Aachen, dem TÜV und der Det Norske Veritas Germanische Lloyd (DNV GL) kontrolliert.

In Puncto Qualität und verschleißarmer Betrieb spielt die richtige Materialauswahl und -kombination eine maßgebliche Rolle. Daher ist ein hohes Qualitätsniveau oberstes Gebot bei Schaeffler. Zwei Jahre Garantie ohne Kilometerbegrenzung für jedes Bauteil sind deshalb für Schaeffler eine Selbstverständlichkeit.

Ein Beispiel für dieses Qualitätsversprechen sind die Ruville Staubschutzmanschetten. Dank der Verwendung von thermoplastischem Polyurethan (TPU) anstelle des marktüblichen Neopren (CR) wird bei diesem Bauteil eine dauerhafte Abdichtung des Gelenkes erreicht – so hält es deutlich länger Einflüssen wie Wasser, Sand, Staub, UV-Strahlen oder gar Chemikalien stand.

Zudem minimiert die robuste Verarbeitung mögliche Folgen von Montagefehlern und das Material bleibt auch in einem großen Temperaturbereich maximal flexibel.



Um Rostunterwanderung der Oberflächen und damit eine Materialschwächung der Bauteilkörper zu verhindern, werden die Bauteile im Vergleich zu anderen Anbietern im Markt zudem galvanisiert. So kann garantiert werden, dass alle sicherheitsrelevanten Bauteile jederzeit optimal funktionieren.



Galvanisierte Oberflächen und die Verwendung des hochmodernen Manschettenmaterials TPU sorgen für eine verlängerte Lebensdauer.

Artikelgruppen

	Achszapfen, Achskörper	GearBOX	Reparatursatz, Schaltgetriebe
	Axialgelenk, Spurstange		Reparatursatz, Spannarm-Keilrippenriemen
	Drehstäbe Satz		Riemenscheibe, Generator
	Drehstab		Riemenscheibe, Kurbelwelle
	Faltenbaldsatz, Antriebswelle		Riemenscheibensatz, Kurbelwelle
	Federbeinstützlager		Riemenspanner, Zahnriemen
	Flexible Kupplungsmuffe-Satz		Schlepphebel, Motorsteuerung
	Geber-/Nehmerzylindersatz, Kupplung		Schraubensatz, Schwungrad
	Geberzylinder, Kupplung		Schwingungsdämpfer, Keilrippenriemen
	Gelenksatz, Antriebswelle		Schwingungsdämpfer, Zahnriemen
	Generatorfreilauf		Schwungrad
	Impulsgeber, Kurbelwelle		Spannarm, Keilrippenriemen
	Keilriemen		Spannarm, Zahnriemen
	Keilrippenriemen		Spannrolle, Keilriemen
	Keilrippenriemensatz		Spannrolle, Keilrippenriemen
	Kette, Ölpumpenantrieb		Spannrolle, Zahnriemen
	Kettensatz, Ölpumpenantrieb		Spurstange
	Kupplungssatz		Spurstangenkopf
	Kupplungssatz Pro		Stabilisator, Fahrwerk
	Lagerzapfen, Spannrollenhebel		Stange/Strebe, Stabilisator
	Lenker, Radaufhängung		Steuerkettensatz
	Montagesatz, Trag-/Führungsgelenk		Steuerventil, Nockenwellenverstellung
	Montagewerkzeugsatz, Achszapfen (Achskörper)		Stößel, Hochdruckpumpe
	Nehmerzylinder, Kupplung		Trag-/Führungsgelenk
	Nockenwelle		Umlenk-/Führungsrolle
	Nockenwellensatz		Ventilstößel
	Nockenwellenversteller		Wasserpumpe
	Radlager		Wasserpumpe + Keilrippenriemensatz
	Radlagersatz		Wasserpumpe + Zahnriemensatz
	WheelPro – enthält 2x Radlagersatz		Werkzeugsatz, Steuerzeiten
	Reparatursatz, Achskörper		Wälzlager, Federbeinstützlager
	Reparatursatz, Achszapfen (Achskörper)		Zahnriemensatz
	Reparatursatz, Federbeinstützlager		Zentralventil, Nockenwellenverstellung

Seitenaufbau

- a Modell
- d Artikelnummer-/gruppe
- g Artikelspezifische Fahrzeuginformationen
- b Baujahr
- e Seitenzahl für numerische Liste/ Stückliste
- f Motorcode
- c Informationen zur Artikelverwendung

a	b	c	d	e
		i	SCHAEFFLER	
FORD				
TRANSIT / TOURNEO CUSTOM				
2.2 TDCi CVFF; CYF4; CYFF; DRF4; DRFF; DRFG; (74-114kW) f	04.12-	SAC excl.	626 3093 33 415 0562 10 411 0120 10 532 0470 10 532 0477 10 534 0308 10 535 0160 10 FB 4EPK922 FB 6EPK873 538 0465 10 OILP 553 0223 10	
		A/C A/C # F-554766.XX g A/C 1x	713 6791 20 713 6791 50 713 6791 60	
		FAG 250, 260, 270, 280 290, 300, 310 330, 350, 390, 410 470	713 6791 20 713 6791 50 713 6791 60	
		RUVILLE ↔ ↔; STANDARD ↔	915272 915274 915297	

Beispiel

Sie haben ein Fahrzeug und suchen das richtige Ersatzteil – Beispiel: Ford Transit, Baujahr 2012, Vorderachse

- 1 Fahrzeug im Katalog suchen
- 2 evtl. Vorderachse oder andere Kriterien berücksichtigen
- 3 Artikelnummer suchen











a	b	c	d	e
		i	SCHAEFFLER	
FORD				
TRANSIT / TOURNEO CUSTOM				
2.2 TDCi CVFF; CYF4; CYFF; DRF4; DRFF; DRFG; (74-114kW) 1	04.12-	SAC excl.	626 3093 33 415 0562 10 411 0120 10 532 0470 10 532 0477 10 534 0308 10 535 0160 10 FB 4EPK922 FB 6EPK873 538 0465 10 OILP 553 0223 10	
		A/C A/C # F-554766.XX A/C 1x	713 6791 20 3 713 6791 50 713 6791 60	
		FAG 250, 260, 270, 280 290, 300, 310 2 330, 350, 390, 410 470	713 6791 20 713 6791 50 713 6791 60	
		RUVILLE ↔ ↔; STANDARD ↔	915272 915274 915297	

Informationen zur Artikelverwendung

	Benötigte Stückzahl		nicht für Achsbaumuster
	Einbauseite außen		für Herstellernummer
	Einbauseite innen		Herstellereinschränkung
	Einbauseite beidseitig		Generatornummer
	Einbauseite Hinterachse		Achsausführung
	Einbauseite Vorderachse		Motorcode/-bauart
	Einbauseite Getriebeseitig		Nutzlast (kg)
	Einbauseite vorne links / Vorderachse links		erhöhte Nutzlast
	Einbauseite vorne rechts / Vorderachse rechts		nicht für erhöhte Nutzlast
	Einbauseite hinten links / Hinterachse links		Sondereinsatzfahrzeug
	Einbauseite hinten rechts / Hinterachse rechts		nicht für Sondereinsatzfahrzeuge
	Einbauseite links		für Artikelnummer / OE Nummer
	Einbauseite rechts		nicht für Artikelnummer / OE Nummer
	Einbauseite oben		für Fahrgestellnummer
	Einbauseite unten		für Pendelachse
	Einbauseite radseitig		für Starrachse
	Einbauseite stirnseitig		für Lenkachse
	für Getriebe-ID		für Einzelradaufhängung
	Angetriebene Aggregate: Generator		für Baumuster
	Angetriebene Aggregate: Spannrolle		nicht für Baumuster
TURBOC	Angetriebene Aggregate: Turbokompressor	EURO 4	für Abgasnorm Euro 4
	Angetriebene Aggregate: Wasserpumpe	EURO 5	für Abgasnorm Euro 5
	Angetriebene Aggregate: Lüfter	EURO 5	nicht für Abgasnorm Euro 5
A/C	Angetriebene Aggregate: Klimakompressor	EURO 6	für Abgasnorm Euro 6
	Angetriebene Aggregate: Servopumpe	EURO 6	nicht für Abgasnorm Euro 6
	Angetriebene Aggregate: Zwischenscheibe		Zähnezahl ABS-Ring
	Angetriebene Aggregate: Nockenwelle		für Ausstattungsvariante
FWD	Antriebsart Frontantrieb		nicht für Ausstattungsvariante
RWD	Antriebsart Heckantrieb		für Getriebenummer
4WD	Antriebsart Allrad		nicht für Getriebenummer
	Felgengröße (Zoll)		für Getriebtyp
	nicht für Felgengröße (Zoll)		für Schaltgetriebe
BM	Achsbaumuster		für Rippenanzahl

 SEQU	für Schaltgetriebe Sequentiell	 SPORT	für Fahrzeuge ohne Sportfahrwerk
 SEQU	nicht Schaltgetriebe Sequentiell	ISTANDARD	für Fahrzeuge mit Standardfahrwerk
 SEMI	Getriebe: Halbautomatik		für Fahrzeuge mit verstärktem Fahrwerk
 SEMI	Getriebe: nicht für Halbautomatik		für Fahrzeuge ohne verstärktes Fahrwerk
G5	für Schaltgetriebe 5-Gang	PTO	für Fahrzeuge mit Motorzapfwelle
G6	für Schaltgetriebe 6-Gang	 PTO	für Fahrzeuge ohne Motorzapfwelle
+	nur in Verbindung mit		für starren Nebenabtrieb
	Form: Rund		für / mit Nebenantrieb
	Form: Oval		mit Freilaufriemenscheibe
	Außendurchmesser (mm)		mit Kurbelwellenriemenscheibe
ABS	für Fahrzeuge mit ABS		Bereifung: mit Einfachbereifung
 ABS	nicht für Fahrzeuge mit ABS		Bereifung: mit Doppelbereifung
	Außentorx		Bereifung: nicht für Doppelbereifung
	Befestigungsart: 3-Punkt Befestigung	OPTION	wahlweise
LHD	Linkslenker		verlängerter Radstand
RHD	Rechtslenker		nicht für verlängerter Radstand
A/C	für Fahrzeuge mit Klimaanlage		verkürzter Radstand
 A/C	für Fahrzeuge ohne Klimaanlage		nicht für verkürzten Radstand
	für Fahrzeuge mit Diesel-Partikel-Filter (DPF)		ABS Lochsegment
 	für Fahrzeuge ohne Diesel-Partikel-Filter (DPF)		ABS Zahnsegment
	für Fahrzeuge mit elektr. Zusatzheizung		für Motoren mit Zweimassenschwungrad
	für Fahrzeuge ohne elektr. Zusatzheizung		für Motoren ohne Zweimassenschwungrad
	für Fahrzeuge mit Servolenkung	 TR	für Länderausführung Türkei
	für Fahrzeuge ohne Servolenkung	 TR	Länderausführung nicht für Türkei
	für Fahrzeuge mit Servotronic-Lenkung / mit elektr. Servolenkung		Radnabe / Radnabendurchmesser
	für Fahrzeuge ohne Servotronic-Lenkung / ohne elektr. Servolenkung		Achslast
 A/C	für Fahrzeuge mit Dachklimaanlage		für Brems Scheibendurchmesser [mm]
	für Fahrzeuge mit Riemenstpanndämpfer		Koppelstange
	für Fahrzeuge ohne Riemenstpanndämpfer		Gelenkart: Tripodegelenk
START/STOP	für Fahrzeuge mit Start-Stopp-Funktion		Gelenkart: Kugelgleichlaufgelenk
 START/STOP	für Fahrzeuge ohne Start-Stopp-Funktion		Einbauseite: an Querlenker
	für Fahrzeuge mit Stabilisator		Einbauseite: an Drehstab
SPORT	für Fahrzeuge mit Sportfahrwerk		für Fahrzeuge mit verstärktem Stabilisator

Informationen zur Artikelverwendung

	Besondere Aufbauform		Dichtung
	für Fahrzeuge mit Starter-generator		Kurbelwellendichtring
	für Fahrzeuge ohne Starter-generator		Zahnrad
	für Schwungradhersteller LuK		Vollsatz
	für Schwungradhersteller Sachs		Einzelteile siehe Stückliste
	für Schwungradhersteller Valeo		

Abkürzungen

SAC	Selbstnachstellende kupplung	ORGA	Organummer
DC	Gleichstrom	VERSION	Version
BS	Ausgleichwelle	VET	VET-Nummer
HYDP	Hydraulikpumpe	ACC	Klimaautomatik
AirComp	Luftkompressor	HA	Halter
VP	Vakuumpumpe	V	Spannung (Volt)
OILP	Ölpumpe	incl.	Inklusive
MY	Modelljahr	excl.	Exklusive
INJP	Einspritzpumpe	+	mit
HD	Verstärkt	—	ohne



Die Servicemarke für Werkstattprofis.

Mit REPERT bieten wir umfassende Serviceleistungen rund um unsere Produkte und Reparaturlösungen von LuK, INA, FAG und Ruville an. Sie suchen gezielte Informationen zur Schadensdiagnose? Oder benötigen Sie konkrete Arbeitshilfen, die Ihnen den Werkstattalltag erleichtern? Ob Onlineportal, Servicehotline oder Events – REPERT bietet Ihnen alle technischen Serviceleistungen.

ARBEITEN

- Produktsortiment
- repxpert Online-Katalog
- Einbauanleitungen
- Produktvorteile
- Verbesserter Bonusshop
- Schadensdiagnose

LERNEN

- Produktwissen
- Trainingsangebote und Trainingsinhalte
- How-to-Videos

INFORMIEREN

- Eventkalender
- Neuigkeiten zu Produkten, Services und vielem mehr

Registrieren Sie sich jetzt – mit wenigen Klicks und kostenfrei unter: www.repxpert.de

Tagesaktuelle Informationen zu den Produkten der Marken LuK, INA, FAG und Ruville: 0800 1 753-333*

*kostenfreie Rufnummer, Mo. – Fr. von 8.00 – 17.00 Uhr

TecDoc



Katalog-Aktualisierung/Nachträge? Zukünftig kein Problem!

Nutzen Sie die Möglichkeiten, die Ihnen die TecDoc-DVD bietet. Damit ist gewährleistet, dass Ihnen vierteljährlich die aktuellen Katalogdaten für Ihr Tagesgeschäft zur Verfügung stehen.

Bestellungen richten Sie bitte an:

TecAlliance GmbH
Arnikaweg 3
D-51109 Köln
Tel. +49 (0) 221/66 00-112
Fax +49 (0) 221/66 00-100
e-mail: tecdoc@tecalliance.net

Online Garantiebearbeitung durch TecWarranty



Light Commercial Vehicles – a developing market	20
Product highlights from Schaeffler in the Automotive Aftermarket	22
Part groups	28
Page layout	29
Part use information	30

CITROËN	114
BERLINGO	114
JUMPER	127
FIAT	139
DOBLO	139
DUCATO	151
FIORINO	176
SCUDO	178
TALENTO	182
FORD	183
TRANSIT	183
FUSO (MITSUBISHI)	216
CANTER	216
GAZ	216
GAZELLE	216
HYUNDAI	217
H-1	217
H200	221
IVECO	222
DAILY	222

MAN	289
TGE	289
MERCEDES-BENZ	290
SPRINTER	290
VITO	357
MITSUBISHI	375
CANTER	375
L200	376
L300	376
NISSAN	376
CABSTAR	376
INTERSTAR	377
NT400	386
NV200	386
NV300	388
NV400	390
PRIMASTAR	401
OPEL	410
COMBO	410
MOVANO	418

VIVARO	444
PEUGEOT	463
BOXER	463
EXPERT	474
PARTNER	481
RENAULT	495
KANGOO	495
MASTER	508
TRAFIC	543
TOYOTA	563
HIACE	563
VAUXHALL	569
COMBO	569
MOVANO	576
VIVARO	597
VW	615
CADDY	615
CRAFTER	635
LT	641
TRANSPORTER	642

 Inhalt ... 3

 Contenu ... 35

 Índice ... 51

 Indice ... 67

 Spis treści ... 83

 Содержание ... 99

Numerical list	678
----------------	-----

This catalogue, or any part of it, may not be copied without our written permission. We cannot accept any responsibility,

or claim, for errors which may occur. We reserve the right to alter specifications and/or construction.

Light Commercial Vehicles – a developing market

Delivering growth

Light Commercial Vehicles are already an indispensable part of our everyday lives. Every type of delivery van is more in demand than ever before. With a projected market growth of eight percent per year, it is the fastest growing vehicle segment and the backbone of the commercial transport business. And this trend is accelerating rapidly, because the popularity of online trade is increasing dramatically and the demand for ever faster deliveries straight to the front door is higher than ever.

That stretch of road from the final distribution center to the consumer – also known as the “last mile” – is where the biggest growth is happening, in the so-called “CEP” market (Courier, Express and Parcel): Industry experts predict that parcel sizes will reduce, the number of packages sent will more than double, and same-day express deliveries will become a reality. As a result, there is a rising demand for smaller vans that will enable fast and versatile deliveries. An important criterion, especially for urban areas: because, by 2025, one quarter of the world’s population will live in the 600 largest cities and generate more than half of the global economic output.

Identifying potentials

The booming delivery van business holds out tremendous potential for independent service garages and opens up new business opportunities. Because delivery vehicles must be fast and flexible in urban traffic, perform reliably in high-mileage service, transport heavy loads, and operate perfectly, sometimes under extremely harsh conditions. There are parcel delivery services, couriers, craftsmen and retailers, whose vehicles can make up to 120 stops per day. Exceeding 100,000 kilometers per year is not unusual – often under constant

deadline pressure. Under these circumstances, high wear and regular repairs are inevitable.

Independent garages can become part of this continuously growing market by expanding their previous customer base to include commercial customers and offering new services for delivery vans. For the fast and easy repair of Light Commercial Vehicles, Schaeffler’s Automotive Aftermarket division offers transmission, engine and chassis solutions designed for simple and efficient installation, reducing downtime.

The sale of additional garage services and spare parts can increase workshop efficiency and provides a good basis for positioning your business as a delivery van specialist: Unlike the passenger car segment, with its very large range of models, much of the delivery van market can be covered with a few standard models such as the Ford Transit, the Mercedes-Benz Sprinter, the Fiat Ducato and the VW Transporter. One of every ten European LCVs is a Ford Transit, making it by far the most popular model, followed by the Mercedes-Benz Sprinter and the VW Transporter.

New business opportunities are also emerging for existing commercial vehicle repairers: For commercial and fleet customers, what counts is a fast and reliable repair that gets the vehicle back out on the road again as soon as possible, because downtime is expensive. One lost day can cost the vehicle operator up to 1,000 Euros. That makes operating costs the dominant competitive advantage in a sector fraught by time and cost pressure.



The transport industry is booming. The strong growth of online trade is fueling Courier, Express and Parcel services and also an increasing demand for Light Commercial Vehicles.



Delivery vans have such high market share and market growth that every commercial vehicle garage should consider integrating the associated services into their portfolio and actively marketing them.

Cross-brand portfolio for commercial-use vehicles

Around the clock, seven days a week: Commercial-use vehicles such as panel vans, dump trucks, flat-bed trucks and buses demand extremely high availability under the harshest conditions, day in and day out. As a result, they are subjected to higher wear than passenger cars and therefore must be repaired more often.

This is precisely where Schaeffler makes a real difference with its easily and rapidly installed repair solutions. Along with repair costs, what matters above all in the business-to-business environment is repair-related downtime. The easier the repair solution is to install, the faster the vehicle will be out on the road again. High-quality products with a long service life also result in extended service intervals. Schaeffler has identified these specific automotive aftermarket requirements and in the future will orient its portfolio across all four brands – LuK, INA, FAG and Ruville – even more towards the customer needs of transport companies and fleet operators. The range includes components and repair solutions for transmission, engine and chassis – all in the highest quality and all from a single source.

All products for Light Commercial Vehicles are developed with the aim of increasing mobility and reducing operating costs. Schaeffler is focused on establishing and expanding a range of durable and cost-optimized repair solutions and a cross-brand portfolio for popular vehicles such as the Ford Transit and the Mercedes-Benz Sprinter. Fleet managers, vehicle operators, service garages and also the parts trade can all benefit from this in equal measure.

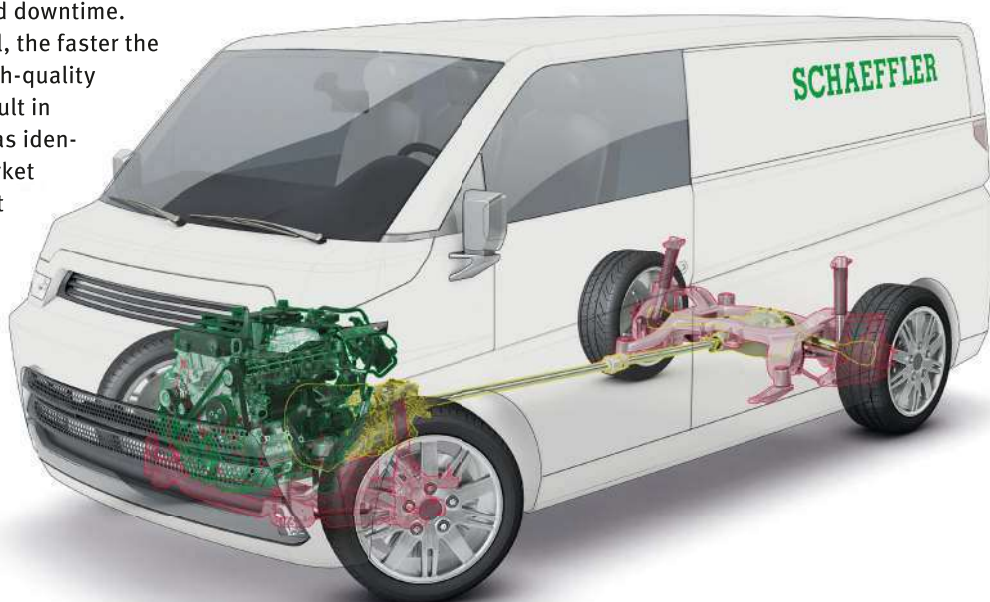

Everything from a single source – repair solutions for transmission, engine and chassis.



Product highlights from Schaeffler in the Automotive Aftermarket

Impact Torque Limiter

Longer service life thanks to overload protection

LCVs are subjected to extreme stresses: maximum loading up to the limit of the gross vehicle weight and an unusually long and therefore sensitive drivetrain in rear-wheel drive configurations, along with driving practices that mirror the tremendous cost and time pressures in the transport sector. Frequent driver changes and stop-and-go traffic are not unusual, adding further to the stress placed on LCVs.

In order to protect the drivetrain from overload, and the resulting premature failure of the vehicle, Schaeffler developed a device to limit peak torques in the drivetrain: the so-called Impact Torque Limiter – a special equipment option for the dual mass flywheel (DMF).

When attempting to match engine speed to the speed of the transmission input shaft very rapidly, sudden peak loads occur at intermittent torque values several times higher than the maximum engine torque.

Over the long term, such impacts can damage the DMF and adversely affect the engine and the drivetrain. In LCVs, those torque peaks are even greater in the fully loaded condition.

The Impact Torque Limiter allows the flange to slip through briefly, thereby absorbing the sudden peak stresses in the drivetrain.

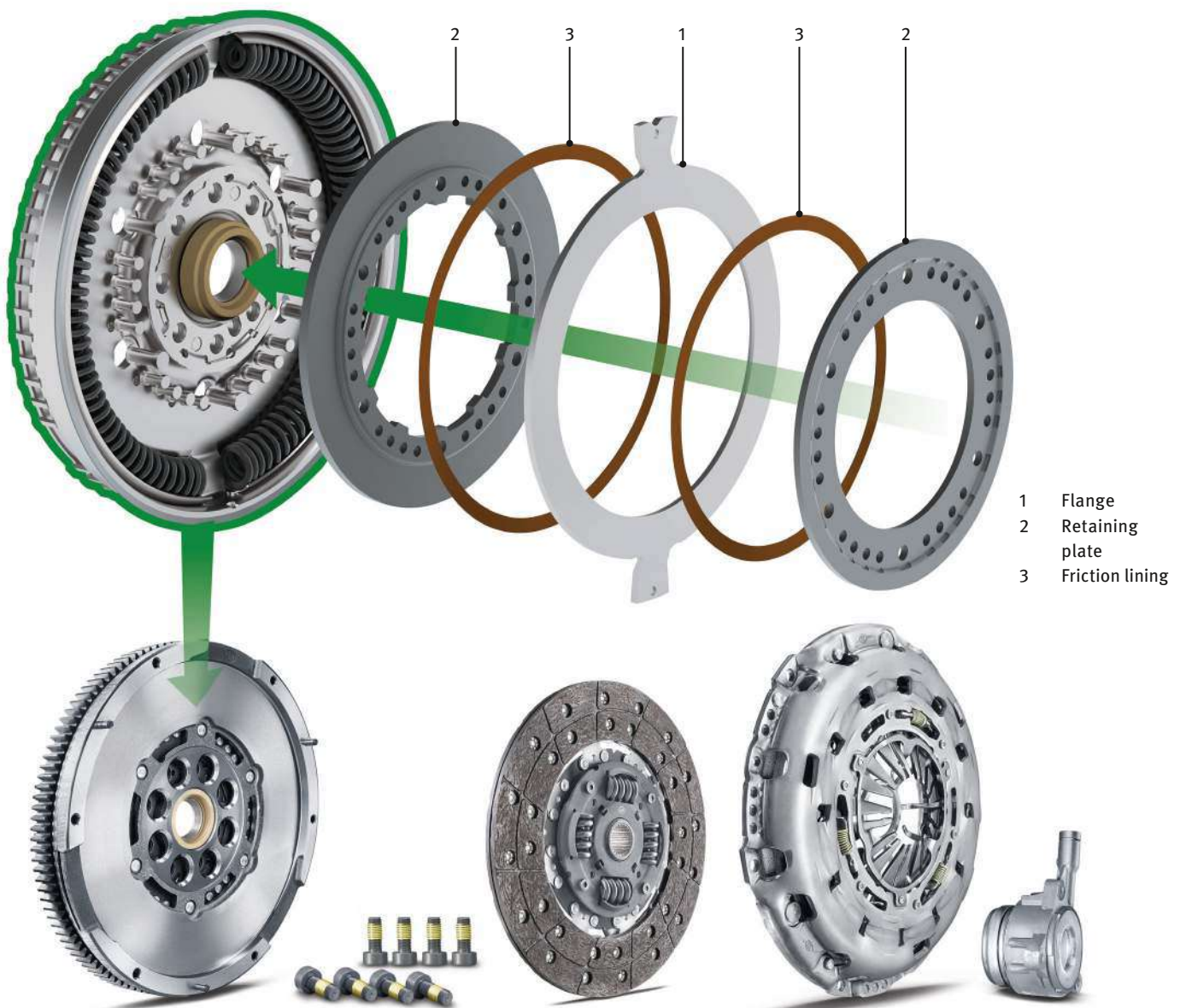

Schaeffler offers the impact-resistant dual mass flywheel specially for the LCV sector, for the Ford Transit and the IVECO Daily for example, and is the only supplier in the market to do so.



Focus on fleet operators – It's got absolutely everything you need: LuK GearBOX

LuK GearBOX: the cost efficient repair solution

Every type of gearbox – regardless of the manufacturer – has its own wear characteristics. In LCVs, which often travel more than 100,000 kilometers per year, it stands to reason that wear occurs earlier. Heavy loads and frequently changing driving styles put additional stress on the gearbox. As a rule, it starts with bearing damage, which becomes noticeable when the gearbox makes a hissing or grinding noise. Without taking suitable action, this could result in a costly vehicle breakdown.

The LuK GearBOX concept is based on an intensive analysis of the primary causes of manual transmission failures. The repair solution includes separate components for eliminating these specific causes of failure.

The LuK GearBOX contains all of the main bearings, seal elements and other wear parts that should be replaced during a professional repair, because they are subjected to high operational stresses. Special tools designed to simplify each repair complete the offer.



The LuK GearBOX includes separate components for eliminating specific causes of failure, including main bearings, sealing elements and wear parts.

Engine and front end auxiliary drive

Sustainable perfectly attuned for your success

Daily up to 120 start-stop operations, constantly fluctuating rotational speeds in city traffic, long idling phases e.g. at traffic lights lead to extreme vibrations – the engines of light commercial vehicles are exposed to constant stress, which ultimately lead to increased wear. Mileages of up to 10 hours a day and in some cases more than 100,000 kilometers a year come on top of this. In Europe, about 85% of all light commercial vehicles are equipped with a diesel engine, a rather unsteady system despite many advantages, at least in terms of vibration.

Despite all the adversities, commercial vehicle operators cannot afford any downtime. Schaeffler therefore offers comprehensive product solutions both for the timing drive and for the auxiliary drive, which is becoming increasingly important.

With its “vehicle solutions” approach, Schaeffler always focuses on the complete vehicle and offers transmission, engine and chassis repair solutions for the most common models.

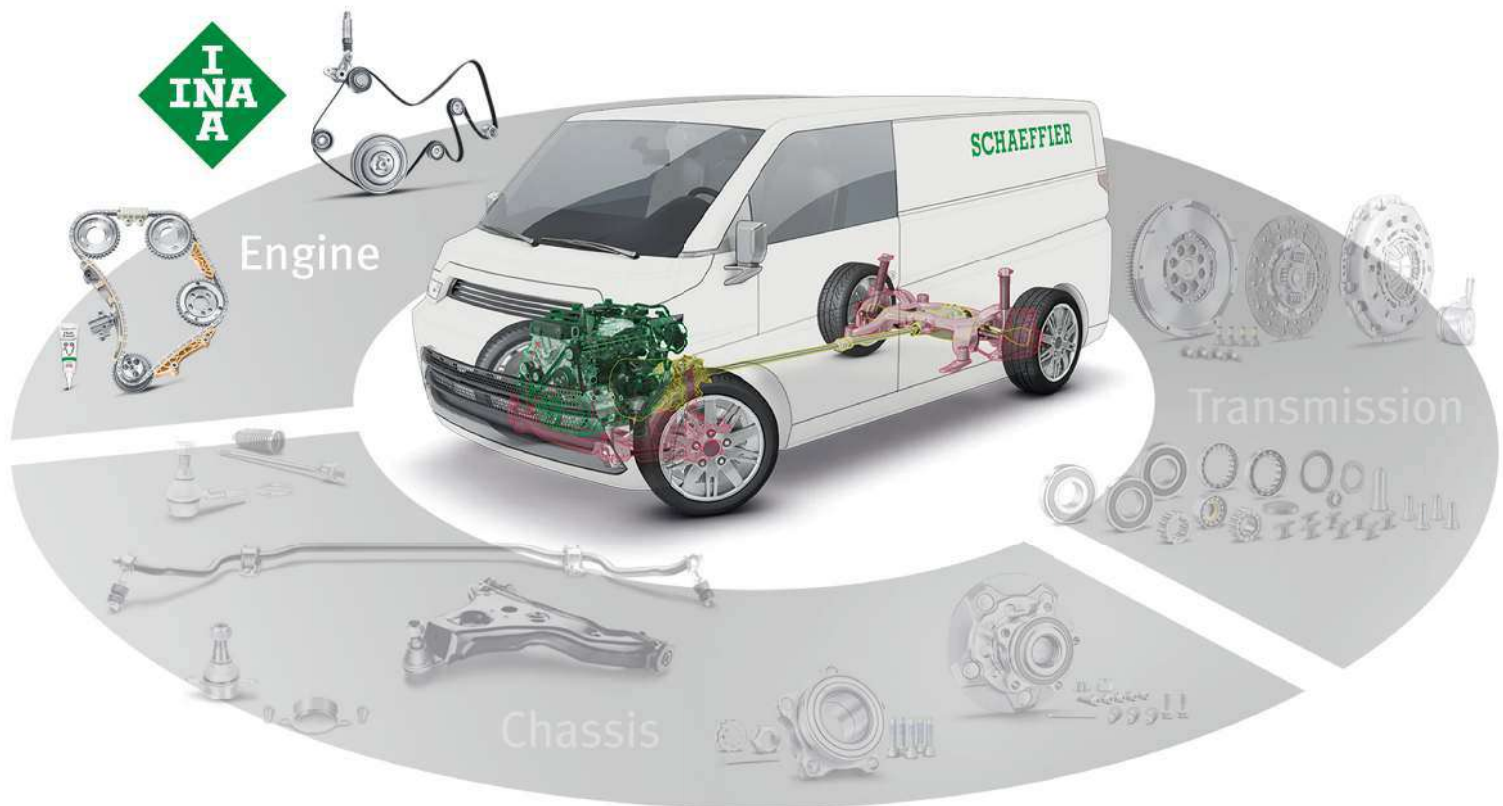

With the INA FEAD KIT, Schaeffler offers perfectly attuned complete solutions for sustainable repairs of front end auxiliary drives. The repair kit always includes belt, tensioner and idler pulleys as well as all necessary accessory parts. Components in the timing drive are exposed to extreme loads. One more reason to replace the complete system whenever repairs are required. With its INA brand, Schaeffler offers an extensive portfolio of timing drive repair solutions.

Timing Drive

Around 1/3 of the most common models in the light commercial vehicle segment in Europe are currently equipped with a chain in the timing drive and the numbers are rising. Precision and fitting accuracy are essential for the engine. Since all parts must harmonize perfectly with each other, it makes sense to replace the entire system whenever repair is necessary. All INA Chain Drive KITS are individually adjusted to each engine variation. OE quality is ensured by the co-development with Schaeffler Engineering. Additionally our additiv “Chain Protect” developed together with Liqui Moly guarantees higher durability of the timing drive.

Chain Drive KITS (excerpt):

- | | |
|--|--|
| <ul style="list-style-type: none"> • Ford Transit (2,0L, 2,2L, 2,4L)
Models until 2006 and 2006–2014
559018730
559018830
559015230
559017630
559018930
559019330
559018430 | <ul style="list-style-type: none"> • Mercedes Benz Sprinter (T1N, NCV, VS30)
Models until 2006 and 2006–2018
559003910
559004510
559004010
559005110
559004910
559005010
559004610 |
|--|--|



Front end auxiliary drive

The front end auxiliary drive is also becoming increasingly important for light commercial vehicles. As the vehicle often functions as workplace, comfort and equipment have reached a level that only upper-class cars have reached so far. Although a failure of the system does not automatically result in a breakdown of the vehicle, the components powered by the front end auxiliary drive are indispensable, whether generator, air conditioning compressor or water pump. So as soon as the engine is repaired, a preventive replacement of the assembly groups might be a good opportunity. The heavy loads caused by vibrations and the continuous operation of the commercial vehicle are of course the reason for the wear. Schaeffler is addressing this issue with a range of products designed to meet these requirements. Special lubricants designed for very low temperatures during winter or continuous operation throughout the year, ensure reliable function.

INA FEAD KITS (excerpt):

- | | |
|--|--|
| <ul style="list-style-type: none"> • Ford Transit (2,0L, 2,2L, 2,4L)
Models until 2006 and 2006–2014
529030110
529030130 (incl. waterpump)
529036410
529036430 (incl. waterpump)
529039010 | <ul style="list-style-type: none"> • Mercedes Benz Sprinter (T1N, NCV, VS30)
Models until 2006 and 2006–2018
529014010
529013910
529033310
529005010
529036110 |
|--|--|





FAG wheel bearing repair solution for LCVs

Rapid wheel bearing replacement

The FAG wheel bearing solution for Mercedes-Benz Sprinter, Viano and Vito models, as well as the VW Crafter, is designed to save both time and money. Instead of replacing the entire steering knuckle, Schaeffler developed a special tool that allows the knuckle to remain on the vehicle during a wheel bearing replacement. Replacing just the wheel bearing eliminates the need for wheel alignment after installation.

This clever repair procedure saves the garage several work steps and takes up to 60 percent less time than a conventional wheel bearing replacement.

Optimized repair procedures like this create new business opportunities for the independent garage: fleet operators and transport companies benefit from minimized downtimes and the increased availability of their commercial vehicles, which builds customer loyalty. The previous customer base expands to include commercial customers and opens up sales opportunities for additional garage services and spare parts.

FAG wheel bearing sets

- 713 6680 10
Mercedes-Benz Sprinter/VW Crafter up to 1850 kg axle load
- 713 6680 20
Mercedes-Benz Sprinter/VW Crafter above 1850 kg axle load
- 713 6680 50 Mercedes-Benz Vito and Viano



FAG special tool

- 400 6199 10

The FAG special tool is indispensable for the correct removal and installation of the FAG LCV wheel bearing sets.



Steering and chassis parts

Uncompromising quality for the toughest requirements

In order to be able to withstand the everyday challenges of the transport business, steering and chassis parts from Schaeffler are intelligently designed and absolutely reliable. Each product undergoes an intensive testing process before it reaches the market. All components are checked on a test stand in Schaeffler's own laboratory with regard to dimensions, function and material quality. Component quality is also monitored through inspections by independent institutions such as the Rhine-Westphalia Institute of Technology (RWTH) in Aachen, TÜV and Det Norske Veritas Germanische Lloyd (DNV GL).

When it comes to quality, reliability and durability, the right choice and combination of materials play an essential role. That's why high quality is Schaeffler's top priority, so it goes without saying that Schaeffler provides a two-year unlimited mileage warranty on every component.

One example of this quality claim is Ruville dust cover sleeves. Thanks to the use of thermoplastic polyurethane (TPU) instead of the neoprene (CR) typically found on the market, Ruville sleeves provide a durable steering system seal that is able to withstand the effects of water, sand, dust, UV radiation and even chemicals for a much longer period.

In addition, the robust construction minimizes the possible consequences of installation errors and the material also retains maximum flexibility over a wide range of temperatures.



In order to prevent the formation of rust on the surfaces, and an accompanying material degradation of the component body, the components are galvanized – unlike parts offered by the other suppliers on the market. This guarantees that all safety-related components function optimally at all times.



Galvanized surfaces and the use of state-of-the-art TPU sleeve material extend the service life.



Part groups

	Axle journal, axle beam	GearBOX	LuK GearBOX manual gearbox repair kit
	Axial joint, tie rod		Multi-ribbed belt tensioner lever repair kit
	Torsion bar set		Alternator pulley
	Torsion bar		Crankshaft pulley
	Steering gaiter set		Crankshaft pulley kit
	Strut mount		Timing belt tensioner
	Adjustable coupling sleeve set		Valve train finger follower
	Master and slave cylinder set		Flywheel bolt kit
	Master cylinder		Multi-ribbed belt vibration damper
	CV joint kit		Timing belt vibration damper
	Overrunning alternator pulley		Flywheel
	Encoder, crankshaft		Multi-ribbed belt tensioner lever
	V-belt		Timing belt tensioner lever
	Multi-ribbed belt		V-belt tensioner pulley
	Multi-ribbed belt set		Multi-ribbed belt tensioner pulley
	Oil pump drive chain		Timing belt tensioner pulley
	Timing chain kit for oil pump drive		Tie rod
	LuK RepSet		Tie rod end
	LuK RepSet with Concentric Slave Cylinder (CSC)		Stabilizer
	Bearing journal, tensioner pulley lever		Rod/strut, stabilizer
	Track control arm		Timing chain kit
	Ball joint kit		Camshaft phaser solenoid valve/Camshaft phaser solenoid valve with housing
	Axle journal kit		Roller type mechanical tappet
	Slave cylinder		Ball joint
	Camshaft		Deflection/guide pulley
	Camshaft kit		Rocker/tappet
	Variable camshaft phaser		Water pump
	Wheel bearing		Multi-ribbed belt kit with water pump
	Wheel bearing kit		Timing belt kit with water pump
	WheelPro – contains 2x wheel bearing kits		Tool set, timing settings
	Axle beam repair kit		Strut mount bearing
	Axle journal repair kit		Timing belt kit
	Strut mount repair kit		Central valve

Page layout

- a** Model
- b** Year of manufacture
- c** Information for using items
- d** Item group/number
- e** Page number for numerical list/
parts list
- f** Engine code
- g** Item-specific vehicle information

a	b	c	d	e
			SCHAEFFLER	
FORD				
TRANSIT / TOURNEO CUSTOM				
2.2 TDCi CVFF; CYF4; CYFF; DRF4; DRFF; DRFG; (74-114kW) f	04.12-	SAC excl.	626 3093 33 415 0562 10 411 0120 10 532 0470 10 532 0477 10 534 0308 10 535 0160 10 FB 4EPK922 FB 6EPK873 538 0465 10 OILP 553 0223 10	
		; A/C ; A/C # F-554766.XX g ; A/C 1x	713 6791 20 713 6791 50 713 6791 60	
		250, 260, 270, 280 290, 300, 310 330, 350, 390, 410 470	713 6791 20 713 6791 50 713 6791 60	
		↔ ↔; STANDARD ↔	915272 915274 915297	

Example

You have a vehicle and are looking for the correct spare part – example: Ford Transit, 2012, front axle

- 1** Search for vehicle in the catalog
- 2** Take into account any type of axle or other specifications
- 3** Search for item number

a	b	c	d	e
			SCHAEFFLER	
FORD				
TRANSIT / TOURNEO CUSTOM				
2.2 TDCi CVFF; CYF4; CYFF; DRF4; DRFF; DRFG; (74-114kW) 1	04.12-	SAC excl.	626 3093 33 415 0562 10 411 0120 10 532 0470 10 532 0477 10 534 0308 10 535 0160 10 FB 4EPK922 FB 6EPK873 538 0465 10 OILP 553 0223 10	
		; A/C ; A/C # F-554766.XX ; A/C 1x	713 6791 20 3 713 6791 50 713 6791 60	
		250, 260, 270, 280 290, 300, 310 2 330, 350, 390, 410 470	713 6791 20 713 6791 50 713 6791 60	
		↔ ↔; STANDARD ↔	915272 915274 915297	













Part use information

	Quantity		Not for axle construction
	Installation position: exterior		For manufacturer number
	Installation position: interior		Manufacturer constraint
	Installation position: on both sides		Alternator number
	Installation position: rear axle		Axle design
	Installation position: front axle		Engine code/engine model
	Installation position: gearbox side		Payload (kg)
	Installation position: left front axle		Increased payload
	Installation position: right front axle		Not for increased payload
	Installation position: left rear axle		Service vehicle
	Installation position: right rear axle		Not for service vehicles
	Installation position: left side		For item number / OE number
	Installation position: right side		Not for item number / OE number
	Installation position: top		For chassis number
	Installation position: bottom		For floating axle
	Installation position: wheel side		For rigid axle
	Installation position: front		For steering axle
	Gearbox ID		For single wheel suspension
	Driven unit: alternator		For model
	Driven unit: tensioner pulley		Not for model
TURBOC	Driven unit: Turbocharger	EURO 4	For vehicles with Euro 4
	Driven unit: Water pump	EURO 5	For vehicles with Euro 5
	Driven unit: fan	EURO 5	Not for vehicles with Euro 5
A/C	Driven unit: air-conditioning compressor	EURO 6	For vehicles with Euro 6
	Driven unit: steering pump	EURO 6	Not for vehicles with Euro 6
	Driven unit: intermediate disc		Number of teeth for ABS encoder
	Driven unit: camshaft		For equipment variant
FWD	Front wheel drive		Not for equipment variant
RWD	Rear wheel drive		Gearbox number
4WD	Four wheel drive		Not for gearbox number
	Rim size (inches)		For gearbox type
	Not for rim size (inches)		For manual gearboxes
BM	Axle construction		Number of belt ribs

	For sequential manual gearboxes	SPORT	For vehicles without sport chassis
SEQU	Not for sequential manual gearboxes	STANDARD	For vehicles with standard chassis
	For semi-automatic systems		With reinforced chassis
SEMI	Not for semi-automatic systems		Without reinforced chassis
G5	5-speed gearboxes	PTO	For vehicles with PTO
G6	6-speed gearboxes	PTO	For vehicles without PTO
+	Only for use in connection with		For rigid power take-off
	Shape: round		Auxiliary drive
	Shape: oval		Overrunning alternator pulley
	Bearing outer diameter [mm]		Crankshaft pulley
ABS	For vehicles with ABS		For single wheel axle
ABS	For vehicles without ABS		For twin wheel axle
	External Torx		Not for twin wheel axle
	Mounting type: 3-point mounting	OPTION	Optional
LHD	For left hand drive vehicles		For extended wheelbase
RHD	For right hand drive vehicles		Not for extended wheelbase
A/C	For vehicles with air-conditioning		Shortened wheelbase
A/C	For vehicles without air-conditioning		Not for shortened wheelbase
	For vehicles with diesel particulate filter (DPF)		ABS hole segment
	For vehicles without diesel particulate filter (DPF)		ABS tooth segment
	For vehicles with electric auxiliary heater		For vehicles with a dual mass flywheel
	For vehicles without electric auxiliary heater		For vehicles without a dual mass flywheel
	For vehicles with power steering		Country version: Turkey
	For vehicles without power steering		Country version: not for Turkey
	For vehicles with servotronic steering		Wheel hub
	For vehicles without servotronic steering		axle load
	For vehicles with roof air-conditioning unit		For brake disc diameter [mm]
	For vehicles with belt tension damper		Coupling rod
	For vehicles without belt tension damper		Tripod joint
START/STOP	Vehicles with start/stop		Installation position: CV joint
START/STOP	Vehicles without start/stop		Installation position: track control arm
	For vehicles with stabilizer		Installation position: torsion bar
SPORT	For vehicles with sport chassis		With reinforced stabilizer



Part use information

	Special body variant		Gasket / seal
	For vehicles with starter alternator		Crankshaft seal
	For vehicles without starter alternator		toothed sprocket
	For LuK manufactured flywheels		Complete kit
	For Sachs manufactured flywheels		List of components
	For Valeo manufactured flywheels		

Abbreviations

SAC	self-adjusting clutch	ORGA	ORGA/DAM number
DC	direct current	VERSION	version
BS	Balancer shaft	VET	From VET-number / to VET-number
HYDP	hydraulic pump	ACC	automatic climate control
AirComp	air compressor	HA	With holder
VP	vacuum pump	V	voltage (volt)
OILP	oil pump	incl.	including
MY	model year	excl.	excluding
INJP	injection pump	+	with
HD	heavy-duty	—	without



The service brand for garage professionals.

Under the REPERT brand we offer a comprehensive package of services for the products and repair solutions of the LuK, INA, FAG, and Ruville brands. Looking for specific information or damage diagnosis? Are you in need of particular tools to make your everyday garage routine easier? Whether online portal, service hotline, installation instructions and videos, training seminars, or events – all technical services are provided in just one place.

WORK

- Product range
- REPERT online catalog
- Repair instructions
- Product advantages
- Improved bonus shop
- Failure diagnosis

LEARN

- Product knowledge
- Training opportunities and training content
- How-to-videos

INFORM

- Event calendar
- The latest product updates and service information

Become a member free of charge at www.repxpert.com

TecDoc



Catalog updates/additions? No problem in the future!

Benefit from the opportunities offered by the TecDoc DVD. This ensures that you receive quarterly updates of the catalogue data for your daily operations.

Send your orders to:

TecAlliance GmbH
Arnikaweg 3
D-51109 Köln
Phone +49 (0) 221/66 00-112
Fax +49 (0) 221/66 00-100
e-mail: tecdoc@tecalliance.net

Online warranty processing by TecWarranty





Véhicules Utilitaires Légers : un marché en expansion	36
Produits phares de Schaeffler sur le marché de la rechange automobile	38
Groupes d'articles	44
Mise en page	45
Informations sur l'utilisation du véhicule	46

CITROËN	114
BERLINGO	114
JUMPER	127
FIAT	139
DOBLO	139
DUCATO	151
FIORINO	176
SCUDO	178
TALENTO	182
FORD	183
TRANSIT	183
FUSO (MITSUBISHI)	216
CANTER	216
GAZ	216
GAZELLE	216
HYUNDAI	217
H-1	217
H200	221
IVECO	222
DAILY	222

MAN	289
TGE	289
MERCEDES-BENZ	290
SPRINTER	290
VITO	357
MITSUBISHI	375
CANTER	375
L200	376
L300	376
NISSAN	376
CABSTAR	376
INTERSTAR	377
NT400	386
NV200	386
NV300	388
NV400	390
PRIMASTAR	401
OPEL	410
COMBO	410
MOVANO	418

VIVARO	444
PEUGEOT	463
BOXER	463
EXPERT	474
PARTNER	481
RENAULT	495
KANGOO	495
MASTER	508
TRAFIC	543
TOYOTA	563
HIACE	563
VAUXHALL	569
COMBO	569
MOVANO	576
VIVARO	597
VW	615
CADDY	615
CRAFTER	635
LT	641
TRANSPORTER	642

 Inhalt ... 3

 Content ... 19

 Índice ... 51

 Indice ... 67

 Spis treści ... 83

 Содержание ... 99

Liste numérique	678
-----------------	-----

Reproduction, en totalité ou en partie, uniquement avec notre permission. Les demandes d'indemnisation fondées sur les informations contenues dans ce catalogue ne sont pas autorisées. S'il est fait référence aux numéros de pièces des

fabricants de véhicules, ceci est uniquement à des fins de comparaison. L'utilisation de ces informations dans les factures adressées au propriétaire du véhicule n'est pas autorisée.

Véhicules Utilitaires Légers : un marché en expansion

Un segment porteur

De nos jours, les véhicules utilitaires légers font partie intégrante de notre quotidien. Les transporteurs de toutes sortes connaissent une demande sans précédent. Avec une croissance du marché prévue à 8% chaque année, ils constituent le segment automobile à la plus forte croissance et l'épine dorsale du marché des transports à usage commercial. La tendance est à la hausse, car la popularité du commerce en ligne s'accroît de jour en jour et les livraisons plus rapides jusqu'au domicile sont demandées plus que jamais.

Cette section allant du dernier centre de distribution au consommateur, également appelée « dernier kilomètre », connaît la plus forte croissance dans le marché dit CEP (courrier, express et colis). Selon les pronostics, la taille des paquets va réduire, le nombre de paquets va doubler et les livraisons express en un jour vont devenir de plus en plus courantes. En conséquence, la demande de transporteurs qui permettent d'effectuer des livraisons rapides et efficaces augmente. Il s'agit là d'un critère important, surtout pour les zones urbaines. En effet, d'ici à 2025, un quart de la population mondiale vivra dans les 600 plus grandes villes et générera plus de la moitié de la production économique mondiale.

Détecter les potentiels

Le marché des transporteurs en plein essor représente un énorme potentiel pour les garages indépendants et ouvre de nouveaux modèles économiques. En effet : les véhicules de transport doivent faire preuve de rapidité et de flexibilité dans le trafic urbain, présenter des kilométrages élevés, transporter des charges lourdes et dans certains cas fonctionner parfaitement dans les conditions les plus difficiles. Les services d'envoi de colis, les livreurs, les entreprises de commerce de détail et les artisans effectuent jusqu'à 120 arrêts par jour à bord de ce type de véhicule. Il n'est pas rare non plus qu'ils dépassent les 100 000 kilomètres par an, le tout sous une pression

constante. Ces véhicules sont alors sujets à une forte usure et à des frais de réparation élevés.

Les garages indépendants peuvent participer à ce marché en croissance constante en élargissant leur base de clients existants pour y inclure des clients professionnels et en offrant de nouveaux services pour les transporteurs. Pour une réparation rapide et facile des véhicules utilitaires légers, Schaeffler propose pour le marché de la rechange indépendante, des solutions de réparation pour la transmission, le moteur et le châssis, qui se distinguent par une installation simple et rapide, ce qui réduit les temps d'immobilisation.

La vente de prestations supplémentaires d'atelier et de pièces de rechange crée plus de capacité dans le garage et lui offre de bonnes conditions pour se positionner en tant que spécialiste des transports. Tandis que le secteur des véhicules légers présente des modèles très variés, la majorité du marché des transporteurs est couverte par les modèles courants, tels que le Ford Transit, le Mercedes Benz Sprinter, le Fiat Ducato et le VW Transporter. Parmi les véhicules utilitaires légers, le Ford Transit est un des modèles les plus courants. En Europe, un véhicule utilitaire sur dix est un Transit. Ce dernier est suivi par le Mercedes Benz Sprinter et le VW Transporter.

Surtout pour les ateliers de poids lourds, de nouvelles opportunités d'affaires apparaissent dans des conditions connues : pour les clients professionnels, une réparation rapide et fiable revêt une grande importance afin de pouvoir utiliser de nouveau un véhicule dans les plus brefs délais. L'arrêt est onéreux. Un jour d'arrêt d'un véhicule peut coûter jusqu'à 1 000 euros à son opérateur. Par conséquent, les coûts d'exploitation deviennent l'avantage concurrentiel dominant dans une industrie caractérisée par des contraintes de temps et de coûts.



Le secteur des transports est en plein essor. La forte croissance du commerce en ligne alimente les services de livraison express et d'envoi de colis, et par conséquent la demande de véhicules utilitaires légers.



La part de marché et la croissance du marché des transporteurs sont si élevées qu'il serait avantageux pour tout garage de véhicules utilitaires de prendre en compte ce secteur de services dans son portefeuille et de le commercialiser activement.

Un portefeuille couvrant toutes les marques de véhicules utilisés commercialement

24 heures sur 24, 7 jours sur 7. Les véhicules à usage commercial, tels que les fourgons, les camions à benne, les bennes basculantes ou les autobus exigent une disponibilité opérationnelle maximale au quotidien, dans les conditions les plus difficiles. Ils sont soumis à une usure plus élevée et doivent être réparés plus fréquemment que les voitures particulières.

C'est là que Schaeffler intervient, avec ses solutions de réparation faciles et rapides d'installation. Outre les coûts de réparation, les temps d'arrêt liés aux réparations sont particulièrement décisifs dans l'environnement Business to business. Plus la solution de réparation est facile à installer, plus la remise en service du véhicule est rapide. Les produits de haute qualité ayant une longue durée de vie garantissent également des intervalles de maintenance plus espacés. Schaeffler a su reconnaître ces exigences spécifiques dans le marché automobile secondaire et concentre son portefeuille sur les quatre marques - LuK, INA, FAG et Ruville - et prévoit à l'avenir de cibler son activité davantage sur les besoins des clients des entreprises de transports et des gestionnaires de flotte. La gamme comprend des composants et des solutions de réparation pour l'entraînement, le moteur et le châssis - un service tout compris de très haute qualité.

Tous les produits de véhicules utilitaires légers sont conçus dans le but d'accroître la mobilité et de réduire les coûts d'exploitation. L'accent est mis sur l'établissement et le développement de solutions de réparation durables et rentables, ainsi que d'un portefeuille couvrant toutes les marques importantes de véhicules, tels que le Ford Transit ou le Mercedes-Benz Sprinter. Ceci profite aux gestionnaires de flotte, aux opérateurs de véhicules, aux garages et au commerce de pièces détachées.

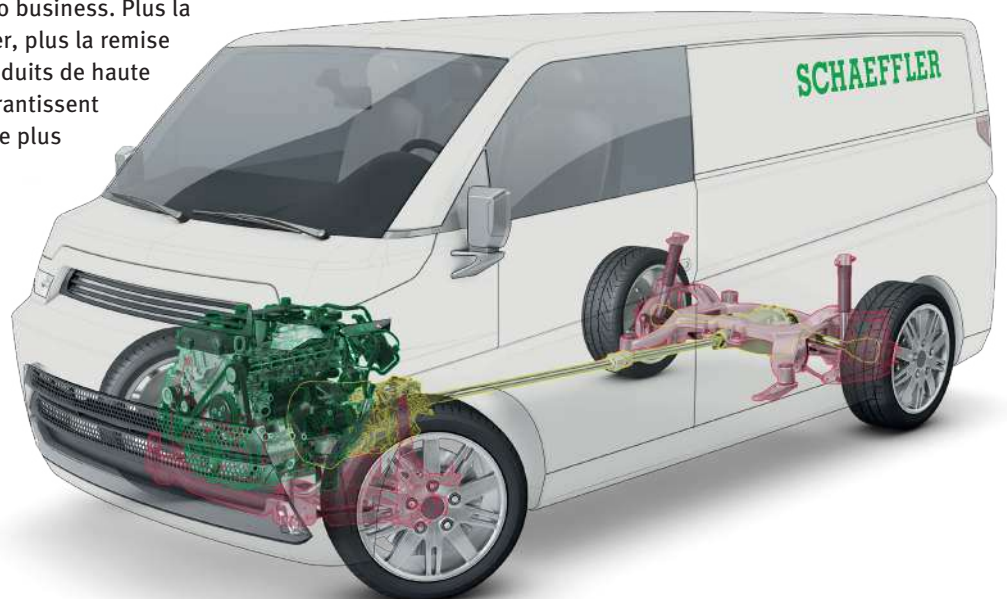

Un service tout-en-un – des solutions de réparation pour la transmission, le moteur et le châssis.

Produits phares de Schaeffler sur le marché de la rechange automobile

Impact Torque Limiter (Flasque avec garniture de friction)

Une longévité accrue grâce à une protection contre les surcharges

Les véhicules utilitaires légers sont soumis à des charges extrêmes : un chargement maximal dans la limite du poids total autorisé, un groupe motopropulseur particulièrement long et donc sensible pour les véhicules à propulsion, ainsi qu'une conduite caractérisée par une pression de temps et de coût énorme dans le secteur des transports. Le changement régulier de conducteur et le système start/stop sont monnaie courante pour les véhicules utilitaires légers, et augmentent donc leur sollicitation.

Schaeffler a mis au point un mécanisme de limitation des couples de pointe dans le groupe motopropulseur, afin de le

protéger contre la surcharge et donc de prévenir une défaillance prématurée du véhicule : L'Impact Torque Limiter - un équipement en option pour le volant bimasse.

Lorsqu'on essaie d'adapter rapidement la vitesse du moteur à la vitesse de l'arbre d'entrée de la boîte de vitesses, des pics de charge brutaux se produisent avec des valeurs de couple temporaires, qui surpassent de beaucoup le couple maximal du moteur.

De tels impacts peuvent endommager de manière permanente le volant bimasse et affecter le moteur, ainsi que le groupe motopropulseur. Pour les véhicules utilitaires légers, ces pics de couple sont encore plus élevés en pleine charge.

L'Impact Torque Limiter permet à la flasque de glisser pendant une courte période, ce qui réduit les pics de charge soudains dans le groupe motopropulseur.

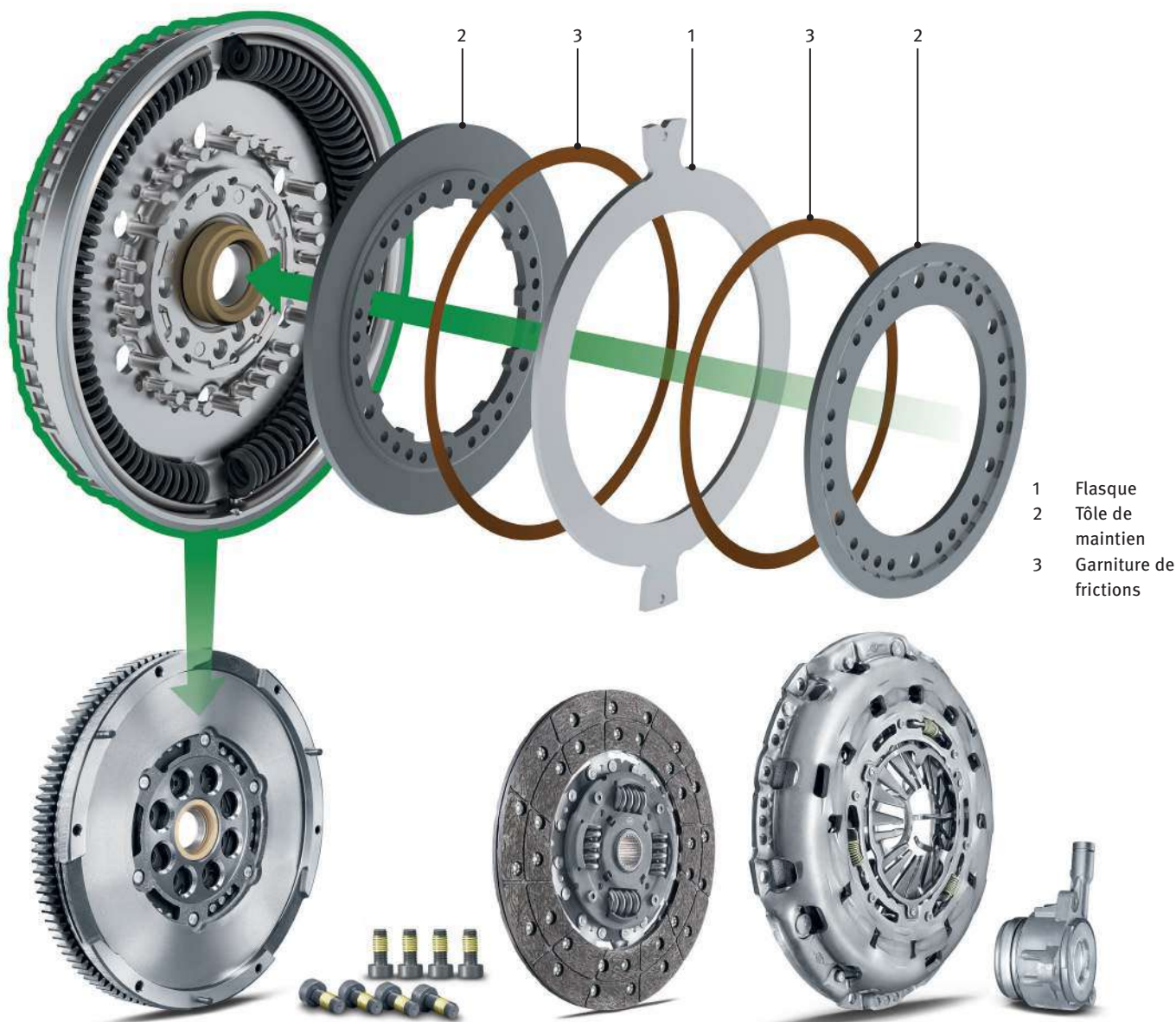

- 1 Flasque
- 2 Tôle de maintien
- 3 Garniture de frictions

Schaeffler propose le volant bimasse en particulier dans le secteur des véhicules utilitaires légers, par exemple pour le Ford Transit et IVECO Daily et constitue le seul fournisseur pour ce segment du marché.



Les gestionnaires de flotte en ligne de mire : La LuK GearBOX répond à tous les besoins

Chaque type de boîte de vitesses - quel que soit le fabricant - présente une tenue à l'usure individuelle. Dans le cas des véhicules utilitaires légers, pour lesquels les kilométrages habituels sont supérieurs à 100 000 kilomètres par an, l'usure se manifeste plus tôt. Un chargement élevé et une conduite souvent variable surchargent la boîte de vitesses. En règle générale, cela commence par un endommagement du palier, qui est perceptible par un bruit de grincement ou de grésillement dans la boîte de vitesses. Sans mesure préventive appropriée, le véhicule utilitaire est susceptible de développer une défaillance coûteuse.

Notre solution d'optimisation des coûts est : La LuK GearBOX.

Le concept de la LuK GearBOX repose sur une analyse approfondie des principales causes de défaillance des transmissions manuelles. La solution de réparation comprend des composants individuels servant à éliminer les causes particulières de défaillance.

La LuK GearBOX est complétée par des paliers principaux, des éléments d'étanchéité et d'autres pièces d'usure, qui doivent être remplacés dans le cadre d'une réparation professionnelle, car ils sont soumis à de fortes contraintes pendant le fonctionnement. Des outils spéciaux pour un processus de réparation simple viennent compléter l'offre.



La LuK GearBOX contient des composants individuels permettant l'élimination des causes particulières de défaillance, incluant les principaux roulements, des éléments d'étanchéité et des pièces d'usure.

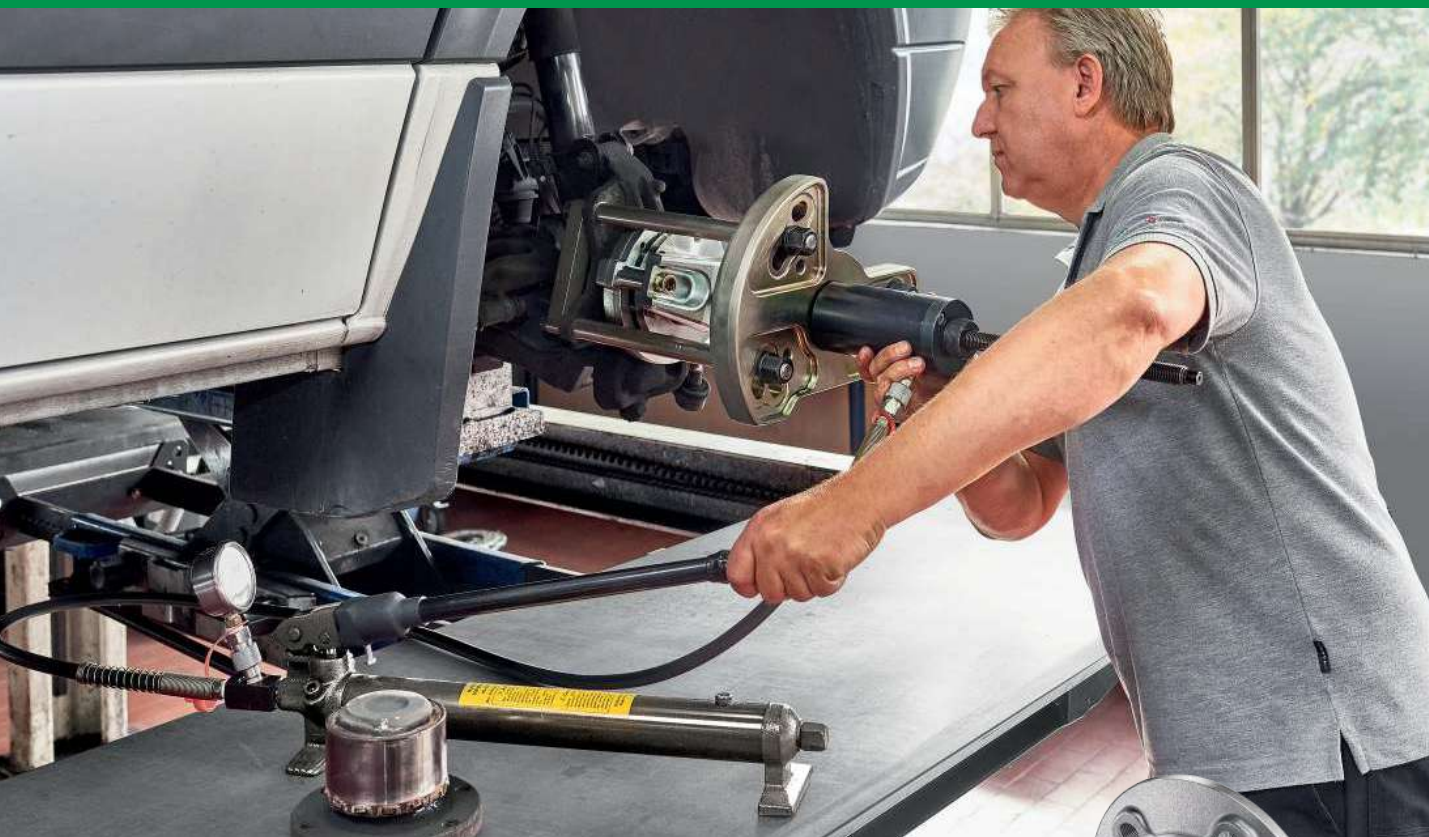

Solution de réparation FAG pour les roulements de roue VUL

Réparation rapide du roulement de roue

La solution de réparation FAG de roulement de roue pour les modèles Sprinter, Viano, Vito et Volkswagen Crafter de Mercedes-Benz offre à la clientèle des avantages optimaux. Au lieu de remplacer intégralement la fusée d'essieu, Schaeffler a développé un outil spécial, grâce auquel la fusée d'essieu reste sur le véhicule pendant la réparation du roulement de roue. Seul le roulement de roue est remplacé et la géométrie du train avant requise après l'assemblage n'est plus nécessaire.

Ce processus de réparation ingénieux permet aux garages d'économiser des étapes de réparation et réduit le temps de travail requis jusqu'à 60 % par rapport aux réparations classiques de roulements de roues.

Ce type de procédure de réparation optimisée crée un nouveau potentiel commercial pour les garages indépendants. Les gestionnaires de flottes et les entreprises de transports bénéficient d'une réduction des temps d'immobilisation et d'un accroissement de la durée de vie du véhicule utilitaire, ce qui participe à la fidélisation des clients. La clientèle existante s'étend aux professionnels et ouvre la possibilité de vendre des prestations de garages supplémentaires, ainsi que des pièces de rechange.

Kits de roulement FAG

- 713 6680 10 Mercedes Benz Sprinter/VW Crafter avec une charge à l'essieu maximale de 1 850 kg
- 713 6680 20 Mercedes Benz Sprinter/VW Crafter avec une charge à l'essieu minimale de 1 850 kg
- 713 6680 50 Mercedes Benz Vito et Viano



Outillage spécial FAG

- 400 6199 10

Pour monter et démonter correctement les kits de roulement de roue FAG, il est essentiel d'utiliser l'outillage spécial FAG.



Pièces de suspension et de direction

Une qualité irréprochable capable de satisfaire les exigences les plus pointues

Les pièces de suspension et de direction Schaeffler sont intelligemment conçues et totalement fiables pour pouvoir faire face aux défis quotidiens du secteur du transport. Chaque produit est soumis à un processus de test particulièrement intensif avant d'être mis sur le marché. Dans le laboratoire Schaeffler, tous les composants sont mis sur le banc d'essai en ce qui concerne la dimension, la fonctionnalité et la qualité des matériaux. En outre, la qualité des composants est vérifiée par des instituts indépendants tels que l'Université technique de Rhénanie-Westphalie (RWTH) à Aix-la-Chapelle, l'association d'inspection technique TÜV et la Det Norske Veritas Germanische Lloyd (DNV GL).

Le bon choix de matériaux et leur combinaison adéquate jouent un rôle décisif en termes de qualité et de fonctionnement résistant à l'usure. Par conséquent, Schaeffler place un niveau de qualité élevé au centre de ses priorités. Assurer une garantie de deux ans sans limite de kilométrage pour chaque composant va donc de soi pour Schaeffler.

Un exemple représentatif de cet engagement qualité est le soufflet cache-poussière Ruville. Grâce à l'utilisation de polyuréthane thermoplastique (par exemple Elastollan®) au lieu du néoprène habituel (CR), ce composant assure une étanchéité permanente du joint - il résiste beaucoup plus longtemps aux influences extérieures, telles que l'eau, le sable, la poussière, les rayons UV ou même les produits chimiques.

De plus, la conception robuste minimise les conséquences possibles d'erreurs de montage et le matériau garde une flexibilité maximale dans une très large plage de températures.



Afin d'éviter l'infiltration de la rouille sur les surfaces et donc l'affaiblissement des matériaux du corps du composant, les composants sont également galvanisés, contrairement à ceux d'autres fournisseurs du marché. Cela garantit à tout moment un fonctionnement optimal des composants essentiels à la sécurité.



































La galvanisation des surfaces et l'utilisation du matériau de soufflet Elastollan® à la pointe de la technologie permettent d'augmenter la durée de vie.

Groupes d'articles

	Tourillon, essieu	GearBOX	Solution de réparation pour boîtes de vitesses
	Rotule axiale, barre de direction		Kit de réparation pour bras tendeur de courroie d'accessoires
	Kit de barre de torsion		Poulie d'alternateur
	Barre de torsion		Poulie/Découpleur de vilebrequin
	Kit de soufflet, arbre d'entraînement		Poulie damper avec vis
	Butée Mc Pherson		Tendeur de courroie
	Kit de manchon d'accouplement ajustable		Linguet, commande du moteur
	Kit de cylindres émetteur/récepteur		Kit de vis, volant bimasse
	Cylindre émetteur		Amortisseur de vibrations, courroie d'accessoires
	Kit de joints homocinétiques		Amortisseur de vibrations, courroie de distribution
	Poulie à roue libre d'alternateur		Volant bimasse
	Impulseur, vilebrequin		Bras tendeur, courroie d'accessoires
	Courroie trapézoïdale		Bras tendeur, courroie de distribution
	Courroie multi-stries		Galet tendeur, courroie trapézoïdale
	Kit d'accessoires		Galet tendeur, courroie multi-stries
	Chaîne pour entraînement de pompe à huile		Galet tendeur, courroie de distribution
	Kit de chaîne pour entraînement de pompe à huile		Rotule de direction
	LuK RepSet		Biellette de direction
	LuK RepSet avec butée hydraulique (CSV)		Stabilisateur, châssis
	Tourillon, levier de rouleau tendeur		Barre/entretoise, stabilisateur
	Bras de suspension		Kit de distribution par chaîne
	Kit de montage, rotule de suspension		Electrovanne pour déphaseur d'arbre à cames
	Kit de montage pour tourillon		Type de roulement pour poussoir mécanique
	Cylindre récepteur		Rotule de suspension et de direction
	Arbre à cames		Galet de renvoi/de guidage
	Kit arbre à cames		Linguet / Poussoir
	Déphaseur d'arbre à cames à commande variable		Pompe à eau
	Roulement de roue		Kit d'accessoires + pompe à eau
	Kit de roulement de roue		Kit de distribution par courroie + pompe à eau
	WheelPro – contient 2 kits de roulement de roue		Outils, calage de distribution
	Kit de réparation, Essieu		Roulement de butée Mc Pherson
	Kit de réparation, tourillon		Kit de distribution par courroie
	Kit de réparation, Butée Mc Pherson		Soupape centrale, distribution variable

Mise en page































- a** Modèle
- b** Année de construction
- c** Informations sur l'utilisation de l'article
- d** Numéro d'article/groupe d'articles
- e** Nombre de pages pour liste numérique/nomenclature
- f** Code moteur
- g** Données du véhicules spécifiques à l'article

a	b	c	d	e
			SCHAEFFLER	
FORD				
TRANSIT / TOURNEO CUSTOM				
2.2 TDCi CVFF; CYF4; CYFF; DRF4; DRFF; DRFG; (74-114kW) f	04.12-	 SAC excl. 	 626 3093 33  415 0562 10  411 0120 10  532 0470 10  532 0477 10  534 0308 10  535 0160 10  FB 4EPK922  FB 6EPK873  538 0465 10  OILP 553 0223 10	
		 A/C  A/C  A/C # F-554766.XX g  A/C 1x	 Set 713 6791 20  Set 713 6791 50  Set 713 6791 60	
		 FAG  250, 260, 270, 280 290, 300, 310  330, 350, 390, 410 470	 Set 915272  Set 915274  915297	
		 RUVILLE  ↔  ↔; I STANDARD  ↔		

Exemple













































Vous disposez d'un véhicule et recherchez la pièce de rechange adéquate - exemple : Ford Transit, année de construction 2012, essieu avant

- 1** Rechercher le véhicule dans le catalogue
- 2** prendre éventuellement en considération l'essieu avant ou d'autres critères
- 3** Rechercher le numéro d'article











a	b	c	d	e
			SCHAEFFLER	
FORD				
TRANSIT / TOURNEO CUSTOM				
2.2 TDCi CVFF; CYF4; CYFF; DRF4; DRFF; DRFG; (74-114kW) 1	04.12-	 SAC excl. 	 626 3093 33  415 0562 10  411 0120 10  532 0470 10  532 0477 10  534 0308 10  535 0160 10  FB 4EPK922  FB 6EPK873  538 0465 10  OILP 553 0223 10	
		 A/C  A/C  A/C # F-554766.XX  A/C 1x	 Set 713 6791 20 3  Set 713 6791 50  Set 713 6791 60	
		 FAG  250, 260, 270, 280 290, 300, 310 2  330, 350, 390, 410 470		
		 RUVILLE  ↔  ↔; I STANDARD  ↔		

Informations sur l'utilisation du véhicule

... X	Quantité nécessaire		pas pour type d'essieu
	Côté d'assemblage extérieur		pour numéro de fabricant
	Côté d'assemblage intérieur		Restrictions du fabricant
	Côté d'assemblage bilatéral		N° de l'alternateur
	Côté d'assemblage essieu arrière		Version d'essieu
	Côté d'assemblage essieu avant		Code moteur/modèle de moteur
	Côté d'assemblage côté transmission		Charge utile (kg)
	Côté d'assemblage avant gauche / essieu avant gauche		Charge utile élevée
	Côté d'assemblage avant droit / essieu avant droit		pas pour charge utile élevée
	Côté d'assemblage arrière gauche / essieu arrière gauche		véhicule d'intervention spéciale
	Côté d'assemblage arrière droit / essieu arrière droit		pas pour véhicule d'intervention spéciale
	Côté d'assemblage gauche		pour numéro d'article/numéro OE
	Côté d'assemblage droit		pas pour numéro d'article/numéro OE
	Assemblage en haut		pour numéro de châssis
	Assemblage en bas		pour essieu oscillant
	Assemblage côté roue		pour essieu rigide
	Côté d'assemblage à l'avant		pour essieu de direction
	N° de boîte de vitesses		pour suspension indépendante
	Organe entraîné : Alternateur		pour modèle
	Organe entraîné : Galet tendeur		pas pour modèle
TURBOC	Organe entraîné : Turbocompresseur	EURO 4	pour norme d'émission Euro 4
	Organe entraîné : Pompe à eau	EURO 5	pour norme d'émission Euro 5
	Organe entraîné : Ventilateur	EURO 5	pas pour norme d'émission Euro 5
A/C	Organe entraîné : Compresseur de climatisation	EURO 6	pour norme d'émission Euro 6
	Organe entraîné : Pompe de direction assistée	EURO 6	pas pour norme d'émission Euro 6
	Organe entraîné : Disque intermédiaire		Nombre de dents anneau ABS
	Organe entraîné : Arbre à cames		pour variante d'équipement
FWD	Traction avant		pas pour variante d'équipement
RWD	Propulsion		N° de boîte de vitesses
4WD	Quatre roues motrices		pas pour type de boîte de vitesses
	Dimensions des jantes (en pouces)		pour type de boîte de vitesses
	pas pour dimension des jantes (en pouces)		pour boîtes de vitesses manuelles
BM	Type d'essieu		pour nombre de nervures

 SEQU	pour boîte séquentielle	TSPORT	pour véhicules sans châssis sport
 SEQU	pas pour boîte séquentielle	I STANDARD	pour véhicules avec châssis standard
 SEMI	pour système semi-automatique		pour véhicules avec châssis renforcé
 SEMI	pas pour système semi-automatique		pour véhicules sans châssis renforcé
G5	pour transmission manuelle 5 vitesses	PTO	pour véhicules avec prise de force
G6	pour transmission manuelle 6 vitesses	PTO	pour véhicules sans prise de force
+	Uniquement avec		pour un entraînement auxiliaire fixe
	Forme : ronde		pour système d'entraînement des accessoires
	Forme : ovale		poulie à roue libre d'alternateur
	Diamètre extérieur (mm)		poulie de vilebrequin
ABS	pour véhicules avec ABS		Pneumatique : pneus simples
ABS	pour véhicules sans ABS		Pneumatique : pneus doubles
	Torx extérieur		Pneumatique : pas pour pneus doubles
	Type de fixation : Fixation 3 points	OPTION	au choix
LHD	Conduite à gauche		Empattement prolongé
RHD	Conduite à droite		pas pour empattement prolongé
A/C	pour véhicules avec climatisation		Empattement raccourci
A/C	pour véhicules sans climatisation		pas pour empattement raccourci
	pour véhicules avec un filtre à particules (FAP) diesel		Secteur d'attelage ABS
	pour véhicules sans filtre à particules (FAP) diesel		Segment denté ABS
	pour véhicules avec chauffage d'appoint électrique		pour moteurs avec volant bimasse
	pour véhicules sans chauffage d'appoint électrique		pour moteurs sans volant bimasse
	pour véhicules avec direction assistée		adapté à une utilisation en Turquie
	pour véhicules sans direction assistée		non adapté à une utilisation en Turquie
	pour véhicules avec direction assistée servotronic/avec direction assistée électr.		Moyeu/diamètre du moyeu
	pour véhicules sans direction assistée servotronic/sans direction assistée électr.		Charge à l'essieu
	pour véhicules avec climatiseur de toit		pour diamètre de disque de frein [mm]
	pour véhicules avec amortisseur de tension de courroie		Barre d'accouplement
	pour véhicules sans amortisseur de tension de courroie		Joint tripode
START/STOP	pour véhicules avec fonction start/stop		Endroit d'assemblage : Joint homocinétique
START/STOP	pour véhicules sans fonction start/stop		Endroit d'assemblage : Triangle/ Bras de suspension
	pour véhicules avec stabilisateur		Endroit d'assemblage : côté barre de torsion
I SPORT	pour véhicules avec châssis sport		pour véhicules avec stabilisateur renforcé

Informations sur l'utilisation du véhicule

	Structure particulière		Joint
	pour véhicules avec alternateur		Bague d'étanchéité de carter
	pour véhicules sans alternateur		Roue dentée/Pignon
	pour fabricant volant moteur LuK		Kit complet
	pour fabricant volant moteur Sachs		Pièces au détail voir nomenclature
	pour fabricant volant moteur Valeo		

Abréviations

SAC	Embrayage à compensation automatique d'usure (Self Adjusting Clutch)	ORGA	Code date fabrication
DC	Courant continu	VERSION	Version
BS	Arbre d'équilibrage	VET	numéro VET
HYDP	Pompe hydraulique	ACC	Climatiseur automatique
AirComp	Compresseur d'air	HA	Support
VP	Pompe à vide	V	Tension (volts)
OILP	Pompe à huile	incl.	Inclus
MY	Année du modèle	excl.	Exclu
INJP	Pompe de carburant	+	avec
HD	Renforcé	-	sans



La marque de service dédiée réparateurs.

Sous la marque Schaeffler REPERT, nous proposons des services exhaustifs qui couvrent tous nos produits et solutions des marques LuK, INA, FAG et Ruville. Vous cherchez des enseignements spécifiques relatifs au diagnostic des pannes ? Vous avez besoin d'outillages spécifiques pour faciliter votre travail quotidien ? Qu'il s'agisse du portail en ligne, de la hotline technique, des instructions ou vidéos de montage ou encore de formations ou de manifestations – vous y trouverez tous les services techniques regroupés sur un seul site.

TRAVAILLER

- Gamme de produit
- Catalogue en ligne
- Manuels de réparation
- Bénéfices produit
- Bonus Shop
- Diagnostic des pannes

APPRENDRE

- Informations produit
- Offre de formations
- Vidéos d'installation

S'INFORMER

- Calendrier évènementiel
- Dernières informations produit et service

Inscrivez-vous gratuitement sur : www.repxpert.fr

TecDoc



Mise à jour de catalogue/compléments ? Dorénavant cela ne vous posera plus de problèmes !

Profitez des possibilités offertes par le DVD TecDoc. Il vous garantit la mise à jour trimestrielle du catalogue, utile à votre activité.

Commandez cet article auprès de :

TecAlliance GmbH
Arnikaweg 3
D-51109 Köln
Tél. +49 (0) 221/66 00-112
Fax +49 (0) 221/66 00-100
e-mail : tecdoc@tecalliance.net

Traitement de garantie en ligne via TecWarranty





La marque de service dédiée réparateurs.

Sous la marque Schaeffler REPERT, nous proposons des services exhaustifs qui couvrent tous nos produits et solutions des marques LuK, INA, FAG et Ruville. Vous cherchez des enseignements spécifiques relatifs au diagnostic des pannes ? Vous avez besoin d'outillages spécifiques pour faciliter votre travail quotidien ? Qu'il s'agisse du portail en ligne, de la hotline technique, des instructions ou vidéos de montage ou encore de formations ou de manifestations – vous y trouverez tous les services techniques regroupés sur un seul site.

TRAVAILLER

- Gamme de produit
- Catalogue en ligne
- Manuels de réparation
- Bénéfices produit
- Bonus Shop
- Diagnostic des pannes

APPRENDRE

- Informations produit
- Offre de formations
- Vidéos d'installation

S'INFORMER

- Calendrier évènementiel
- Dernières informations produit et service

Inscrivez-vous gratuitement sur : www.repxpert.fr

TecDoc



Mise à jour de catalogue/compléments ? Dorénavant cela ne vous posera plus de problèmes !

Profitez des possibilités offertes par le DVD TecDoc. Il vous garantit la mise à jour trimestrielle du catalogue, utile à votre activité.

Commandez cet article auprès de :

TecAlliance GmbH
Arnikaweg 3
D-51109 Köln
Tél. +49 (0) 221/66 00-112
Fax +49 (0) 221/66 00-100
e-mail : tecdoc@tecalliance.net

Traitement de garantie en ligne via TecWarranty





La marque de service dédiée réparateurs.

Sous la marque Schaeffler REPERT, nous proposons des services exhaustifs qui couvrent tous nos produits et solutions des marques LuK, INA, FAG et Ruville. Vous cherchez des enseignements spécifiques relatifs au diagnostic des pannes ? Vous avez besoin d'outillages spécifiques pour faciliter votre travail quotidien ? Qu'il s'agisse du portail en ligne, de la hotline technique, des instructions ou vidéos de montage ou encore de formations ou de manifestations – vous y trouverez tous les services techniques regroupés sur un seul site.

TRAVAILLER

- Gamme de produit
- Catalogue en ligne
- Manuels de réparation
- Bénéfices produit
- Bonus Shop
- Diagnostic des pannes

APPRENDRE

- Informations produit
- Offre de formations
- Vidéos d'installation

S'INFORMER

- Calendrier évènementiel
- Dernières informations produit et service

Inscrivez-vous gratuitement sur : www.repxpert.fr

TecDoc



Mise à jour de catalogue/compléments ? Dorénavant cela ne vous posera plus de problèmes !

Profitez des possibilités offertes par le DVD TecDoc. Il vous garantit la mise à jour trimestrielle du catalogue, utile à votre activité.

Commandez cet article auprès de :

TecAlliance GmbH
Arnikaweg 3
D-51109 Köln
Tél. +49 (0) 221/66 00-112
Fax +49 (0) 221/66 00-100
e-mail : tecdoc@tecalliance.net

Traitement de garantie en ligne via TecWarranty



Vehículos comerciales ligeros: un mercado en crecimiento	52
Productos destacados de Schaeffler en el mercado de recambios de automoción	54
Grupos de artículos	60
Configuración de la página	61
Información sobre el uso del artículo	62

CITROËN	114
BERLINGO	114
JUMPER	127
FIAT	139
DOBLO	139
DUCATO	151
FIORINO	176
SCUDO	178
TALENTO	182
FORD	183
TRANSIT	183
FUSO (MITSUBISHI)	216
CANTER	216
GAZ	216
GAZELLE	216
HYUNDAI	217
H-1	217
H200	221
IVECO	222
DAILY	222

MAN	289
TGE	289
MERCEDES-BENZ	290
SPRINTER	290
VITO	357
MITSUBISHI	375
CANTER	375
L200	376
L300	376
NISSAN	376
CABSTAR	376
INTERSTAR	377
NT400	386
NV200	386
NV300	388
NV400	390
PRIMASTAR	401
OPEL	410
COMBO	410
MOVANO	418

VIVARO	444
PEUGEOT	463
BOXER	463
EXPERT	474
PARTNER	481
RENAULT	495
KANGOO	495
MASTER	508
TRAFIC	543
TOYOTA	563
HIACE	563
VAUXHALL	569
COMBO	569
MOVANO	576
VIVARO	597
VW	615
CADDY	615
CRAFTER	635
LT	641
TRANSPORTER	642

 Inhalt ... 3

 Content ... 19

 Contenu ... 35

 Indice ... 67

 Spis treści ... 83

 Содержание ... 99

Listado numérico	678
------------------	-----

La reproducción, incluso parcial, solo está permitida con nuestra autorización. Las reclamaciones de indemnización basadas en la información de este catálogo quedan excluidas. Cuando se haga referencia a los números de piezas de re-

cambio de los fabricantes de vehículos, se hará únicamente a efectos comparativos. No se permite el uso de dicha información en las facturas al propietario del vehículo.

Vehículos comerciales ligeros: un mercado en crecimiento

Sector en auge

En la actualidad, es imposible imaginar la vida cotidiana sin vehículos comerciales ligeros. Los vehículos de transporte de todo tipo están más solicitados que nunca. Con un crecimiento previsto del mercado del ocho por ciento anual, representan el segmento de vehículos de mayor crecimiento y la columna vertebral del negocio del transporte comercial. La popularidad del comercio en línea está al alza y las entregas urgentes en puerta están en auge.

En esta sección desde el último centro de distribución hasta el consumidor, también denominado «last mile», el mayor crecimiento se produce en el denominado mercado CEP (mensajería, mensajería urgente y paquetería). Según las previsiones, el tamaño del paquete disminuirá, la cantidad de paquetes se duplicará y las entregas en el mismo día se volverán realidad. Como resultado, está en aumento la demanda de vehículos de transporte comerciales que puedan realizar entregas de forma rápida y flexible.

Se trata de un criterio importante, especialmente para zonas urbanas, ya que en 2025 una cuarta parte de la población mundial vivirá en las 600 ciudades más grandes y generará más de la mitad de la producción económica mundial.

Reconocimiento del potencial

El floreciente negocio de los vehículos de transporte ofrece un enorme potencial para los talleres independientes y abre nuevos modelos de negocio. La causa: los vehículos de transporte deben ser rápidos y flexibles en el tráfico de la ciudad, garantizar kilometrajes elevados, transportar cargas pesadas y, en ocasiones, funcionar perfectamente en las condiciones más exigentes. Se trata de empresas de paquetería, transportistas, empresas artesanales y minoristas cuyos vehículos realizan hasta 120 paradas diarias. Incluso los kilometrajes de más de 100 000 kilómetros al año no son poco frecuentes, siempre

bajo la continua presión de los plazos de entrega. Es decir, implican un elevado desgaste y esfuerzo de mantenimiento.

Los talleres independientes pueden participar en este mercado en constante crecimiento al ampliar su base de clientes existente para incluir clientes comerciales y ofrecer nuevos servicios para vehículos de transporte. Para la reparación rápida y sencilla de vehículos comerciales ligeros, la división Automotive Aftermarket de Schaeffler ofrece soluciones de mantenimiento para la transmisión, el motor y el chasis, que se caracterizan por una instalación rápida y sencilla, lo que reduce los períodos de inactividad.

La venta de servicios de taller adicionales y piezas de repuesto genera una mayor utilización del taller y ofrece buenas condiciones para posicionarse como especialista en vehículos de transporte. Mientras la variedad de modelos en el sector de los turismos es muy amplia, la mayor parte del mercado puede cubrirse con vehículos de transporte convencionales, como Ford Transit, Mercedes-Benz Sprinter, Fiat Ducato y Volkswagen Transporter. El Ford Transit es, con diferencia, el modelo más popular entre los vehículos comerciales ligeros. Uno de cada diez vehículos en los 37 países que conforman Europa es un Transit, seguido por Mercedes-Benz Sprinter y Volkswagen Transporter.

Se abren nuevas oportunidades de negocio, especialmente para los talleres de camiones, con condiciones marco ya conocidas: para los clientes comerciales, las reparaciones rápidas y fiables resultan esenciales para que el vehículo vuelva a estar en servicio a la mayor brevedad. El tiempo de inactividad sale caro. Un día perdido puede costar hasta 1000 euros al operador del vehículo. Por ello, los costes de explotación se están convirtiendo en la principal ventaja competitiva en un sector caracterizado por la presión del tiempo y los costes.



La industria del transporte está en auge. El fuerte crecimiento del comercio electrónico impulsa los servicios de paquetería y mensajería urgente y, por consiguiente, la demanda de vehículos comerciales ligeros.



La cuota de mercado y el crecimiento del mercado de los vehículos de transporte son tan elevados que merece la pena considerar la idea de que cada taller de vehículos comerciales incluya dicho servicio en su oferta y lo comercialice de forma activa.

Catálogo multimarca para vehículos comerciales

24 horas al día, siete días a la semana: los vehículos comerciales, como furgonetas, camiones volquetes, plataformas o autobuses, requieren diariamente la máxima disponibilidad operativa en las condiciones más exigentes. Por ello, están sujetos a un mayor desgaste y deben repararse con mayor frecuencia que los automóviles.

Aquí es justamente donde Schaeffler entra en escena con sus soluciones de mantenimiento rápidas y fáciles de incorporar. Además de los costes de reparación, los períodos de inactividad relacionados con las reparaciones resultan decisivos en el entorno Business-to-Business. Cuanto más fácil sea incorporar la solución de reparación, más rápido volverá el vehículo a la carretera. Además, los productos de alta calidad con una larga vida útil garantizan intervalos de servicio prolongados. Schaeffler ha reconocido estos requisitos especiales del mercado de recambios de automoción y centra su catálogo de productos de las cuatro marcas (LuK, INA, FAG y Ruville) en las necesidades de los clientes de las empresas de transporte y de los operadores de flotas. El catálogo incluye componentes y soluciones de mantenimiento para la transmisión, el motor y el chasis, todo ello en la mayor calidad y de un solo proveedor.

Todos los productos para vehículos comerciales ligeros se desarrollan con el objetivo de aumentar la movilidad y reducir los costes de explotación. La atención se centra en elaborar soluciones de mantenimiento duraderas y rentables, así como en un catálogo multimarca para los vehículos más importantes, como el Ford Transit y el Mercedes-Benz Sprinter. Esto beneficia a los gestores de flotas, a los operadores de vehículos y a los talleres, pero también al comercio de piezas.

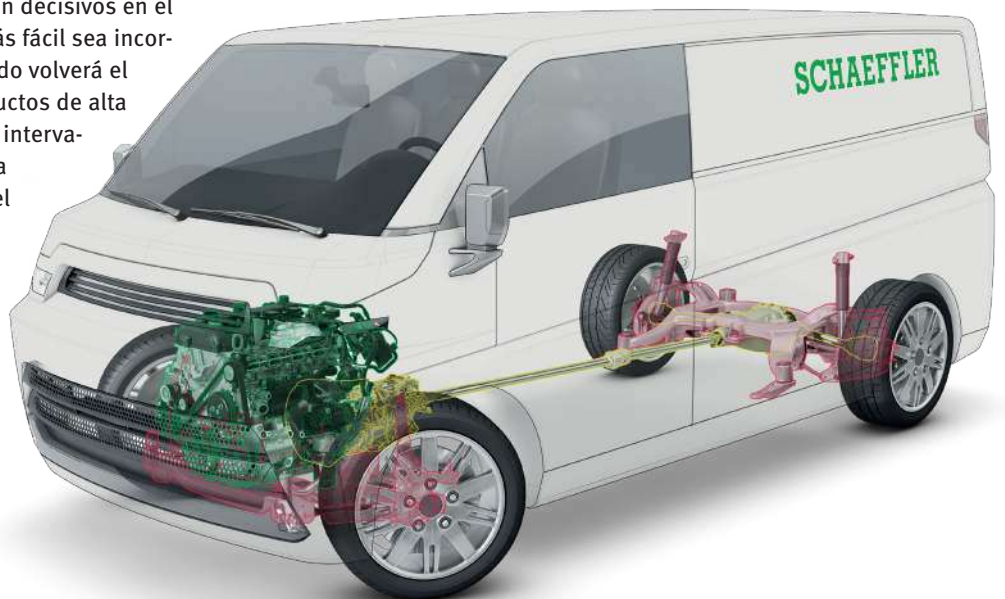

Todo de un solo proveedor: soluciones de mantenimiento para la transmisión, el motor y el chasis.

Productos destacados de Schaeffler en el mercado de recambios de automoción

Limitador de Par

Mayor vida útil gracias a la protección contra sobrecargas

Los vehículos comerciales ligeros están sometidos a cargas extremas: carga máxima hasta el límite del peso total admisible, un tren propulsor especialmente largo y, por lo tanto, sensible para las unidades de tracción trasera y un comportamiento de conducción caracterizado por una enorme presión de costes y tiempo en el sector del transporte. El continuo cambio de conductor y Stop-and-go no resultan atípicos para los vehículos comerciales ligeros y aumentan la presión.

Schaeffler ha desarrollado un mecanismo para limitar los pares máximos en el tren propulsor con el fin de protegerlo contra sobrecargas y, por tanto, contra fallos prematuros del vehículo: el denominado Limitador de par, un equipamiento opcional del volante bimasa.

Al intentar adaptar el número de revoluciones del motor de forma particularmente rápida al número de revoluciones del eje de entrada de la caja de cambios, se generan cargas máximas repentinas con valores de par que, normalmente, son muy superiores al par máximo del motor.

Dichos «impactos» pueden dañar el volante bimasa a largo plazo y tener un efecto negativo en el motor y el tren propulsor. En los vehículos comerciales ligeros, dichos valores máximos de par son aún mayores en caso de carga completa.

El Limitador de par permite que la brida se deslice durante un corto período de tiempo, lo que reduce las cargas máximas repentinas en el tren propulsor.

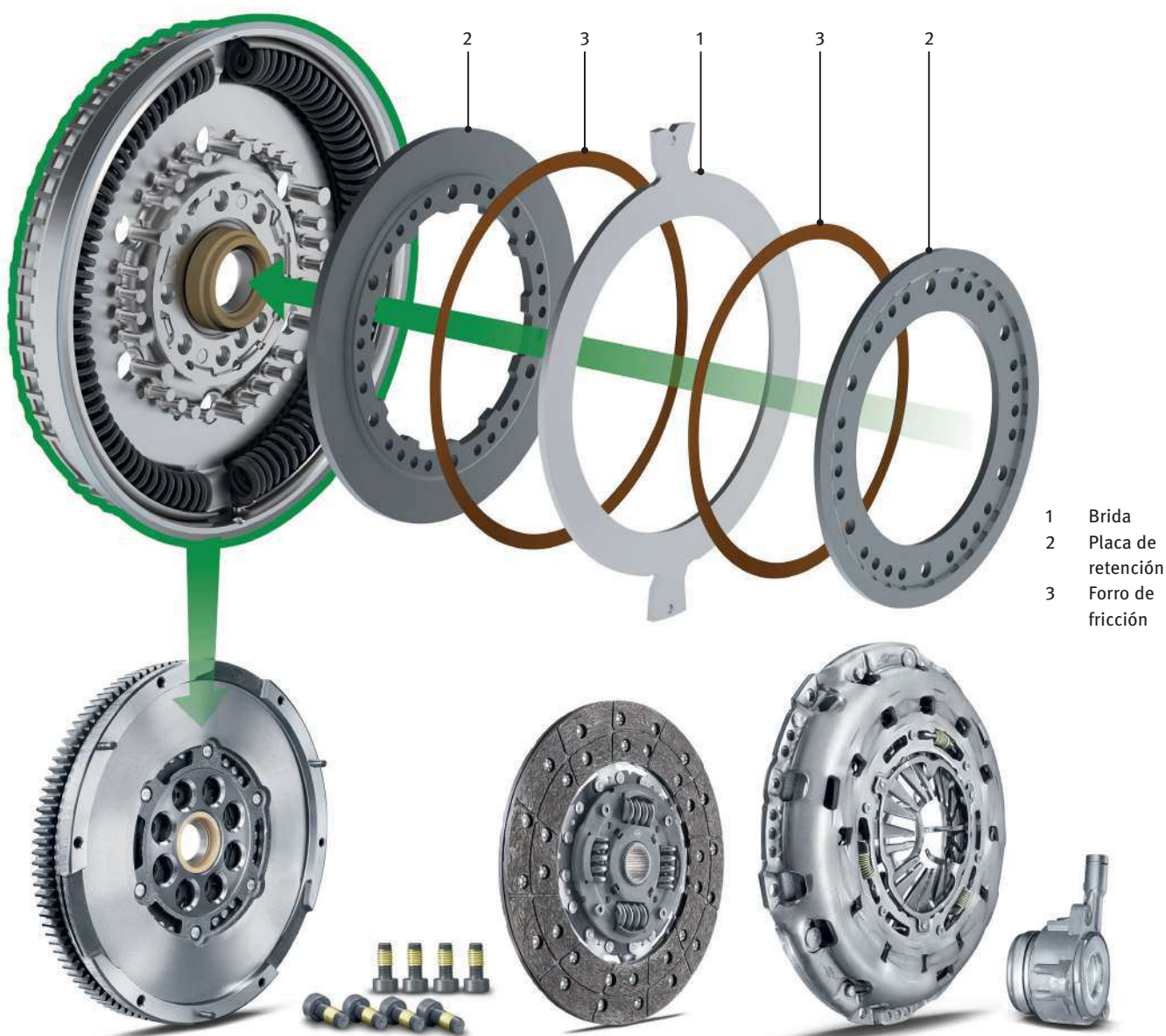

- 1 Brida
- 2 Placa de retención
- 3 Forro de fricción

Schaeffler es el único proveedor del mercado en ofrecer el volante bimasa resistente a los impactos, especialmente en el segmento de los vehículos comerciales ligeros, por ejemplo para el Ford Transit y el IVECO Daily.



Operadores de flotas en primer plano: no falta absolutamente nada, LuK GearBOX

Cada tipo de caja de cambios, independientemente del fabricante, presenta un comportamiento de desgaste único. En los vehículos comerciales ligeros, donde son frecuentes los kilometrajes de más de 100 000 kilómetros al año, el desgaste se produce antes. Las elevadas cargas y los frecuentes cambios en el comportamiento de conducción suponen una carga adicional para la caja de cambios. Por norma general, se empieza por daños en los rodamientos, que se manifiestan por un ruido de rozamiento o esmerilado en la caja de cambios. Si no se toman las medidas adecuadas, se corre el riesgo de que se produzca una avería grave en el vehículo industrial.

Nuestra solución de optimización de costes está aquí: LuK GearBOX.

El concepto de LuK GearBOX se basa en un análisis intensivo de las principales causas de fallo de las transmisiones manuales. La solución de mantenimiento incluye componentes individuales para eliminar causas especiales de fallos.

LuK GearBOX se complementa con rodamientos principales, elementos de obturación y otras piezas de desgaste, que deben sustituirse como parte de un mantenimiento profesional ya que están sometidos a grandes esfuerzos durante el funcionamiento. Las herramientas especiales para un sencillo proceso de reparación completan la oferta.



LuK GearBOX contiene componentes individuales para eliminar las causas de fallos específicas, incluyendo rodamientos principales, los elementos de obturación y las piezas de desgaste.



Procedimiento de cambio de rodamientos de rueda para comerciales ligeros

Reparación rápida del rodamiento

El procedimiento de cambio de rodamientos de rueda de FAG para los modelos Mercedes-Benz Sprinter, Viano, Vito y Volkswagen Crafter ofrece un beneficio óptimo para el cliente. En lugar de sustituir la mangueta completa, Schaeffler desarrolló una herramienta especial con la que la mangueta permanece en el vehículo durante el cambio de los rodamientos. Solo se sustituye el rodamiento y se suprime la alineación de ruedas tras el montaje.

Este ingenioso proceso de mantenimiento ahorra numerosos pasos de trabajo a los talleres y reduce el tiempo de trabajo necesario hasta en un 60 por ciento en comparación con las reparaciones de rodamientos convencionales.

Los procesos de mantenimiento optimizados de este tipo suponen un nuevo potencial de negocio para los talleres independientes: los operadores de flotas y las empresas de transporte se benefician de la reducción de los tiempos de inactividad y de una mayor vida útil del vehículo comercial, lo que refuerza la fidelidad de los clientes. La base de clientes existente se amplía para incluir clientes comerciales y abre la posibilidad de vender servicios de taller adicionales y piezas de repuesto.

Juegos de rodamientos FAG

- 713 6680 10 Mercedes-Benz Sprinter/Volkswagen Crafter hasta 1850 kg de carga por eje
- 713 6680 20 Mercedes-Benz Sprinter/Volkswagen Crafter desde 1850 kg de carga por eje
- 713 6680 50 Mercedes-Benz Vito y Viano



Herramienta especial FAG

- 400 6199 10

La herramienta especial FAG resulta indispensable para el correcto desmontaje y montaje de los juegos de rodamientos FAG.



Piezas de suspensión y dirección

Calidad sin concesiones para los requisitos más exigentes

Los componentes de suspensión y dirección de Schaeffler están diseñados de forma inteligente y totalmente fiable para poder soportar los retos diarios del sector del transporte. Cada producto se somete a un proceso de pruebas especialmente intenso antes de su lanzamiento al mercado. En nuestro propio laboratorio Schaeffler, se someten a pruebas a todos los componentes en cuanto a dimensiones, función y calidad del material. Además, la calidad de los componentes se controla mediante pruebas de institutos independientes como la Rheinisch-Westfälische Technische Hochschule (RWTH) de Aquisgrán, el TÜV y la Det Norske Veritas Germanischer Lloyd (DNV GL).

En términos de calidad y desgaste reducido, la elección y combinación del material desempeñan un papel decisivo. Por lo tanto, la máxima prioridad de Schaeffler es lograr un elevado nivel de calidad. Schaeffler considera la garantía de dos años sin límite de kilometraje para cada componente una cuestión de costumbre.

Un ejemplo de esta promesa de calidad son los guardapolvos Ruville. Gracias al uso de poliuretano termoplástico (Elastollan®) en lugar del neopreno estándar (CR), este componente consigue una estanqueidad permanente de la articulación, por lo que soporta influencias más prolongadas como el agua, la arena, el polvo, los rayos UV o, incluso, los productos químicos.

Además, el robusto procesamiento minimiza las posibles consecuencias de los errores de montaje y el material permanece lo más flexible posible en un amplio rango de temperaturas.



Para evitar la corrosión de las superficies y, por lo tanto, el debilitamiento del material de los cuerpos de los componentes, los componentes también están galvanizados en comparación con otros proveedores del mercado. Esto garantiza que todos los componentes relevantes para la seguridad funcionen de forma óptima en todo momento.



Las superficies galvanizadas y el uso del moderno material Elastollan® garantizan una larga vida útil.

Grupos de artículos

	Muñón del eje, cuerpo del eje	GearBOX	Juego de reparación, transmisión manual
	Articulación axial, tirante		Juego de reparación, correa acanalada de brazo tensor
	Juego de barras de torsión		Polea, generador
	Barra de torsión		Polea, cigüeñal
	Juego de fuelles, eje de accionamiento		Juego de poleas, cigüeñal
	Rodamiento de apoyo del amortiguador		Tensor de correa, correa dentada
	Juego de manguitos de acoplamiento flexibles		Balancín, control del motor
	Conjunto de cilindros transmisor/receptor, acoplamiento		Juego de tornillos, control del motor
	Cilindro transmisor, acoplamiento		Amortiguador de vibraciones, correa acanalada
	Conjunto de articulaciones, eje de accionamiento		Amortiguador de vibraciones, correa dentada
	Polea libre del generador		Volante
	Generador de impulsos, cigüeñal		Brazo tensor, correa acanalada
	Correa trapezoidal		Brazo tensor, correa dentada
	Correa acanalada		Polea tensora, correa trapezoidal
	Juego de correas acanaladas		Polea tensora, correa acanalada
	Cadena, accionamiento de bomba de aceite		Polea tensora, correa dentada
	Conjunto de cadena, accionamiento de bomba de aceite		Bieleta
	Conjunto de acoplamiento		Cabezal del tirante
	Conjunto de acoplamiento Pro		Articulación bieleta
	Muñón del cojinete, palanca de polea tensora		Barra/puntal, estabilizador
	Manillar, suspensión de ruedas		Juego de cadenas de control
	Juego de montaje, articulación de soporte/guía		Válvula de control, ajuste del árbol de levas
	Juego de herramientas de montaje, muñón del eje (cuerpo del eje)		Émbolo, bomba de alta presión
	Cilindro receptor, acoplamiento		Articulación de soporte/guía
	Árbol de levas		Rodillo de desviación/guía
	Conjunto de árboles de levas		Émbolo de válvula
	Ajuste del árbol de levas		Bomba de agua
	Rodamiento		Bomba de agua + juego de correas acanaladas
	Juegos de rodamientos		Bomba de agua + juego de correas dentadas
	WheelPro, contiene 2 juegos de rodamientos		Juego de herramientas, tiempos de control
	Juego de reparación, cuerpo del eje		Rodamiento de apoyo del amortiguador
	Juego de reparación, muñón del eje (cuerpo del eje)		Juego de correas dentadas
	Juego de reparación, rodamiento de apoyo del amortiguador		Válvula central, ajuste del árbol de levas

Configuración de la página

- a Modelo de fabricación
- b Año de fabricación
- c Información sobre el uso del artículo
- d Referencia de artículo
- e Número de página para listado de piezas/listado numérico
- f Código del motor
- g Información sobre el vehículo específica del artículo

a	b	c	d	e
			SCHAEFFLER	
FORD				
TRANSIT / TOURNEO CUSTOM				
2.2 TDCi CVFF; CYF4; CYFF; DRF4; DRFF; DRFG; (74-114kW)	04.12-	SAC excl.	626 3093 33 415 0562 10 411 0120 10 532 0470 10 532 0477 10 534 0308 10 535 0160 10 FB 4EPK922 FB 6EPK873 538 0465 10 OILP 553 0223 10	
			; A/C ; A/C # F-554766.XX ; A/C 1x	
		; 250, 260, 270, 280 290, 300, 310 ; 330, 350, 390, 410 470	Set 713 6791 20 Set 713 6791 50 Set 713 6791 60	
			↔ ↔; I STANDARD ↔	915272 915274 915297

Ejemplo

Ud. tiene un vehículo y busca el repuesto apropiado, por ejemplo: Ford Transit, año de fabricación 2012, eje delantero

- 1 Buscar un vehículo en la lista
- 2 tener en cuenta el posible número de motor u otras especificaciones
- 3 tener en cuenta el posible número











a	b	c	d	e
			SCHAEFFLER	
FORD				
TRANSIT / TOURNEO CUSTOM				
2.2 TDCi CVFF; CYF4; CYFF; DRF4; DRFF; DRFG; (74-114kW)	04.12-	SAC excl.	626 3093 33 415 0562 10 411 0120 10 532 0470 10 532 0477 10 534 0308 10 535 0160 10 FB 4EPK922 FB 6EPK873 538 0465 10 OILP 553 0223 10	
			; A/C ; A/C # F-554766.XX ; A/C 1x	
		; 250, 260, 270, 280 290, 300, 310 ; 330, 350, 390, 410 470	Set 713 6791 20 Set 713 6791 50 Set 713 6791 60	
			↔ ↔; I STANDARD ↔	915272 915274 915297

Información sobre el uso del artículo

... X	Cantidad necesaria		no para modelo de eje
	Lado de montaje exterior		para número de fabricante
	Lado de montaje interior		Limitación del fabricante
	Lado de montaje en ambos lados		Número de generador
	Lado de montaje en eje trasero		Modelo de eje
	Lado de montaje en eje delantero		Tipo/código de motor
	Lado de montaje en lado de la caja de cambios		Carga útil (kg)
	Lado de montaje delantero izquierda/eje delantero izquierda		mayor carga útil
	Lado de montaje delantero derecha/eje delantero derecha		no para mayor carga útil
	Lado de montaje trasero izquierda/eje trasero izquierda		Vehículo especial
	Lado de montaje trasero derecha/eje trasero derecha		no para vehículo especial
	Lado de montaje izquierdo		para número de artículo/número OE
	Lado de montaje derecho		no para número de artículo/número OE
	Lado de montaje superior		para número de bastidor
	Lado de montaje inferior		para eje oscilante
	Lado de montaje en el lado de la rueda		para eje rígido
	Lado de montaje frontal		para eje de dirección
	para ID de caja de cambios		para suspensión independiente
	Grupos accionados: generador		para modelo
	Grupos accionados: polea tensora		no para modelo
TURBOC	Grupos accionados: turbocompresor	EURO 4	para norma de emisión Euro 4
	Grupos accionados: bomba de agua	EURO 5	para norma de emisión Euro 5
	Grupos accionados: ventilador	EURO 5	no para norma de emisión Euro 5
A/C	Grupos accionados: compresor de aire acondicionado	EURO 6	para norma de emisión Euro 6
	Grupos accionados: servobomba	EURO 6	no para norma de emisión Euro 6
	Grupos accionados: arandela intermedia		Número de dientes de anillo ABS
	Grupos accionados: árbol de levas		para variante de equipamiento
FWD	Tipo de propulsión, tracción delantera		no para variante de equipamiento
RWD	Tipo de propulsión, propulsión trasera		para número de caja de cambios
4WD	Tipo de propulsión, tracción total		no para número de caja de cambios
	Tamaño de llanta (pulgadas)		para tipo de caja de cambios
	no para tamaño de llanta (pulgadas)		para transmisión manual
BM	Modelo de eje		para cantidad de aletas

	para transmisión secuencial	SPORT	para vehículos sin chasis deportivo
	no para transmisión secuencial	ISTANDARD	para vehículos con chasis estándar
	Transmisión: semiautomática		para vehículos con chasis reforzado
	Transmisión: no para semiautomática		para vehículos sin chasis reforzado
G5	para transmisión de 5 marchas	PTO	para vehículos con toma de fuerza del motor
G6	para transmisión de 6 marchas	PTO	para vehículos sin toma de fuerza del motor
+	solo en combinación con		para accionamiento auxiliar rígido
	Forma: redonda		para/con accionamiento auxiliar
	Forma: ovalada		para polea libre
	Diámetro exterior (mm)		con polea de cigüeñal
ABS	para vehículos con ABS		Neumáticos: con neumáticos simples
ABS	no para vehículos con ABS		Neumáticos: con neumáticos dobles
	Torx exterior		Neumáticos: no para neumáticos dobles
	Tipo de fijación: Fijación de 3 puntos	OPTION	a elegir
LHD	Vehículo con volante a la izquierda		distancia entre ruedas ampliada
RHD	Vehículo con volante a la derecha		no para distancia entre ruedas ampliada
A/C	para vehículos con aire acondicionado		distancia entre ruedas reducida
A/C	para vehículos sin aire acondicionado		no para distancia entre ruedas reducida
	para vehículos con filtro de partículas diésel (FPD)		Segmento perforado ABS
	para vehículos sin filtro de partículas diésel (FPD)		Segmento dentado ABS
	para vehículos con calefacción adicional eléctrica		para motores con volante de inercia de doble masa
	para vehículos sin calefacción adicional eléctrica		para motores sin volante de inercia de doble masa
	para vehículos con dirección asistida	TR	para la versión de país de Turquía
	para vehículos sin dirección asistida	TR	versión de país no para Turquía
	para vehículos con dirección Servotronic/con dirección asistida eléctrica		Diámetro del cubo de la rueda/cubo de la rueda
	para vehículos sin dirección Servotronic/sin dirección asistida eléctrica		Carga por eje
	para vehículos con aire acondicionado de techo		para el diámetro del disco de freno [mm]
	para vehículos con amortiguador de correa		Barra de acoplamiento
	para vehículos sin amortiguador de correa		Tipo de articulación: articulación trípode
START/STOP	para vehículos con función arranque/parada		Tipo de articulación: articulación con junta esférica
START/STOP	para vehículos sin función arranque/parada		Posición de montaje: sobre barra transversal
	para vehículos con estabilizador		Posición de montaje: sobre barra de torsión
SPORT	para vehículos con chasis deportivo		para vehículos con estabilizador reforzado

Información sobre el uso del artículo

	Diseño especial		Junta
	para vehículos con generador de arranque		Retén del cigüeñal
	para vehículos sin generador de arranque		Rueda dentada
	para el fabricante de volantes de inercia LuK		Juego completo
	para el fabricante de volantes de inercia Sachs		Piezas individuales, véase el listado de piezas
	para el fabricante de volantes de inercia Valeo		

Abreviaturas

SAC	Acoplamiento autoajustable	ORGA	Número de órgano
CC	Corriente continua	VERSION	Versión
BS	Eje de compensación	VET	Número VET
HYDP	Bomba hidráulica	ACC	Aire acondicionado
AirComp	Compresor de aire	HA	Soporte
VP	Bomba de vacío	V	Tensión (voltios)
OILP	Bomba de aceite	incl.	incluido
MY	Año del modelo	excl.	excluido
INJP	Bomba de inyección	+	con
HD	Reforzado	—	sin



La marca de servicios para talleres profesionales.

A través de REPERT ofrecemos numerosos servicios para todos nuestros productos y soluciones de reparación de LuK, INA, FAG y Ruville. ¿Busca información específica para el diagnóstico de averías? ¿O necesita herramientas concretas que faciliten el trabajo diario en el taller? Portal en línea, línea de atención técnica, eventos... REPERT pone a su disposición todo tipo de servicios técnicos.

PARA TRABAJAR

- Gama de productos
- Catálogo en línea de REPERT
- Instrucciones de montaje
- Ventajas de productos
- Programa de puntos mejorado
- Diagnóstico de averías

PARA APRENDER

- Conocimiento del producto
- Oferta y contenidos de formación
- Vídeos de ayuda

PARA INFORMARTE

- Calendario de eventos
- Novedades en productos, servicios y mucho más

Regístrese ahora, en pocos clics y de forma gratuita: www.repxpert.es

TecDoc



¿Actualización o ampliaciones del catálogo? ¡Se acabaron los problemas!

Aproveche las posibilidades que le brinda el DVD TecDoc. Ud. tiene así la seguridad de disponer trimestralmente de los datos de catálogo actualizados para su actividad diaria.

Para sus pedidos diríjase a:

TecAlliance GmbH
Arnikaweg 3
D-51109 Köln
Tel. +49 (0) 221/66 00-112
Fax +49 (0) 221/66 00-100
correo electrónico
tecdoc@tecalliance.net

Procesamiento de garantía en línea por TecWarranty





La marca de servicios para talleres profesionales.

A través de REPERT ofrecemos numerosos servicios para todos nuestros productos y soluciones de reparación de LuK, INA, FAG y Ruville. ¿Busca información específica para el diagnóstico de averías? ¿O necesita herramientas concretas que faciliten el trabajo diario en el taller? Portal en línea, línea de atención técnica, eventos... REPERT pone a su disposición todo tipo de servicios técnicos.

PARA TRABAJAR

- Gama de productos
- Catálogo en línea de REPERT
- Instrucciones de montaje
- Ventajas de productos
- Programa de puntos mejorado
- Diagnóstico de averías

PARA APRENDER

- Conocimiento del producto
- Oferta y contenidos de formación
- Vídeos de ayuda

PARA INFORMARTE

- Calendario de eventos
- Novedades en productos, servicios y mucho más

Regístrese ahora, en pocos clics y de forma gratuita: www.repxpert.es

TecDoc



¿Actualización o ampliaciones del catálogo? ¡Se acabaron los problemas!

Aproveche las posibilidades que le brinda el DVD TecDoc. Ud. tiene así la seguridad de disponer trimestralmente de los datos de catálogo actualizados para su actividad diaria.

Para sus pedidos diríjase a:

TecAlliance GmbH
Arnikaweg 3
D-51109 Köln
Tel. +49 (0) 221/66 00-112
Fax +49 (0) 221/66 00-100
correo electrónico
tecdoc@tecalliance.net

Procesamiento de garantía en línea por TecWarranty





La marca de servicios para talleres profesionales.

A través de REPERT ofrecemos numerosos servicios para todos nuestros productos y soluciones de reparación de LuK, INA, FAG y Ruville. ¿Busca información específica para el diagnóstico de averías? ¿O necesita herramientas concretas que faciliten el trabajo diario en el taller? Portal en línea, línea de atención técnica, eventos... REPERT pone a su disposición todo tipo de servicios técnicos.

PARA TRABAJAR

- Gama de productos
- Catálogo en línea de REPERT
- Instrucciones de montaje
- Ventajas de productos
- Programa de puntos mejorado
- Diagnóstico de averías

PARA APRENDER

- Conocimiento del producto
- Oferta y contenidos de formación
- Vídeos de ayuda

PARA INFORMARTE

- Calendario de eventos
- Novedades en productos, servicios y mucho más

Regístrese ahora, en pocos clics y de forma gratuita: www.repxpert.es

TecDoc



¿Actualización o ampliaciones del catálogo? ¡Se acabaron los problemas!

Aproveche las posibilidades que le brinda el DVD TecDoc. Ud. tiene así la seguridad de disponer trimestralmente de los datos de catálogo actualizados para su actividad diaria.

Para sus pedidos diríjase a:

TecAlliance GmbH
Arnikaweg 3
D-51109 Köln
Tel. +49 (0) 221/66 00-112
Fax +49 (0) 221/66 00-100
correo electrónico
tecdoc@tecalliance.net

Procesamiento de garantía en línea por TecWarranty





Veicoli commerciali leggeri: un mercato in crescita	68
Prodotti di punta Schaeffler per il mercato aftermarket	70
Categoria articolo	76
Struttura della pagina	77
Informazioni sull'uso dell'articolo	78

CITROËN	114
BERLINGO	114
JUMPER	127
FIAT	139
DOBLO	139
DUCATO	151
FIORINO	176
SCUDO	178
TALENTO	182
FORD	183
TRANSIT	183
FUSO (MITSUBISHI)	216
CANTER	216
GAZ	216
GAZELLE	216
HYUNDAI	217
H-1	217
H200	221
IVECO	222
DAILY	222

MAN	289
TGE	289
MERCEDES-BENZ	290
SPRINTER	290
VITO	357
MITSUBISHI	375
CANTER	375
L200	376
L300	376
NISSAN	376
CABSTAR	376
INTERSTAR	377
NT400	386
NV200	386
NV300	388
NV400	390
PRIMASTAR	401
OPEL	410
COMBO	410
MOVANO	418

VIVARO	444
PEUGEOT	463
BOXER	463
EXPERT	474
PARTNER	481
RENAULT	495
KANGOO	495
MASTER	508
TRAFIC	543
TOYOTA	563
HIACE	563
VAUXHALL	569
COMBO	569
MOVANO	576
VIVARO	597
VW	615
CADDY	615
CRAFTER	635
LT	641
TRANSPORTER	642

 Inhalt ... 3

 Content ... 19

 Contenu ... 35

 Índice ... 51

 Spis treści ... 83

 Содержание ... 99

Elenco numerico	678
-----------------	-----

Ristampa, anche per estratto, soltanto con la nostra autorizzazione. Sono esclusi diritti al risarcimento sulla base di dati contenuti nel presente catalogo. Qualora si faccia riferimento ai numeri dei pezzi di ricambio dei produttori del vei-

colo, il fine è esclusivamente comparativo. Non è consentito un utilizzo di simili dati nelle fatture emesse al proprietario del veicolo.

Veicoli commerciali leggeri: un mercato in crescita

Settore in ripresa

Al giorno d'oggi è impossibile immaginare la vita di tutti i giorni senza i veicoli commerciali leggeri. Questa tipologia di veicoli è più che mai diffusa. Con una previsione di crescita del mercato dell'otto per cento annuo, rappresentano il segmento di veicoli in più rapida crescita e la spina dorsale del trasporto commerciale. La popolarità del commercio online è in forte aumento e consegne sempre più veloci fin alla porta di casa sono oggi più richieste che mai.

Su questo ultimo tratto di strada, dal centro di distribuzione fino al consumatore, detto anche "ultimo miglio", si pongono le basi per la crescita del cosiddetto mercato CEP (corriere, espresso e pacchi): Le stime prevedono una riduzione delle dimensioni dei pacchi e un raddoppiamento della quantità, le consegne espresse in giornata diverranno una realtà. Come risultato si ha un aumento della domanda di veicoli commerciali, che possano effettuare le consegne in modo agile e veloce. Si tratta di un requisito importante soprattutto per le aree urbane, poiché entro il 2025 un quarto della popolazione mondiale vivrà nelle 600 città più grandi e genererà più della metà del prodotto economico mondiale.

Riconoscere il potenziale

Il boom del mercato dei veicoli commerciali si traduce in un enorme potenziale per le officine indipendenti e apre la porta a nuovi modelli d'impresa. I furgoni devono circolare nel traffico in modo rapido e flessibile, garantire un chilometraggio elevato, trasportare carichi pesanti e talvolta operare impeccabilmente nelle condizioni più difficili. Stiamo parlando di spedizionieri, corrieri, imprese artigianali e venditori al dettaglio, i cui veicoli effettuano fino a 120 fermate ogni giorno. Non è raro che il chilometraggio annuo superi i 100.000 km, facendo

fronte a scadenze sempre più pressanti. Per questo motivo l'usura e i costi di riparazione sono elevati.

Le officine indipendenti possono entrare in questo mercato in costante crescita ampliando la loro base clienti esistente per includere i clienti aziendali e offrendo loro nuovi servizi per i furgoni. Per la riparazione rapida e semplice dei veicoli commerciali leggeri, la divisione Automotive Aftermarket di Schaeffler offre soluzioni di riparazione per la trasmissione, il motore e il telaio, caratterizzate da un'installazione semplice e rapida che riduce i tempi di fermo del mezzo.

La vendita di servizi accessori e di pezzi di ricambio sfrutta al meglio la capacità dell'officina e pone buoni presupposti per potersi posizionare come specialista nella riparazione dei furgoni: mentre la gamma delle applicazioni autovettura è molto vasta, il mercato dei furgoni si concentra su pochi marchi, quali Ford Transit, Mercedes Benz Sprinter, Iveco Daily e VW Transporter. In particolare il Ford Transit resta di gran lunga il modello più amato nel settore dei veicoli commerciali leggeri. Nelle 37 nazioni europee, un veicolo su dieci è un Transit, seguito dal Mercedes Benz Sprinter e dal VW Transporter.

Nuove opportunità commerciali si aprono soprattutto per le officine per autocarri: per i clienti aziendali è importante effettuare una riparazione in modo rapido e affidabile, per poter rendere nuovamente operativo il mezzo in breve tempo. Stare fermi è dispendioso. Un guasto può costare all'operatore del mezzo fino a 1.000 euro al giorno. Di conseguenza, i costi operativi stanno diventando il vantaggio competitivo dominante, in un settore caratterizzato da una pressione sulle tempistiche e sui costi.



Il settore dei trasporti è in forte crescita. Il boom del commercio online sta stimolando i servizi dei corrieri espressi e di consegna di pacchi, aumentando di conseguenza anche la domanda di veicoli commerciali leggeri.



Il segmento di mercato dei furgoni è così vasto e la sua crescita tanto elevata, che per ogni officina ha senso valutare se offrire e promuovere attivamente servizi in questo settore.

Portfolio multibrand per veicoli commerciali

24 ore su 24, 7 giorni su 7: i veicoli commerciali come i furgoni, i ribaltabili, i pianali o gli autobus richiedono la massima prontezza operativa nelle condizioni più difficili ogni giorno. In questo settore vi sono una maggiore usura e una più frequente necessità di riparazioni che per i veicoli ad uso personale.

Proprio in tale contesto Schaeffler propone soluzioni di riparazione semplici e pratiche. Oltre ai costi di riparazione, nel contesto business-to-business sono decisivi soprattutto i costi di fermo del mezzo. Quanto più facile è l'impiego della soluzione di riparazione, tanto più velocemente il veicolo può tornare su strada. Prodotti di alta qualità con una lunga vita operativa garantiscono inoltre intervalli di manutenzione più lunghi. Schaeffler ha riconosciuto queste esigenze nel mercato dell'Automotive Aftermarket e focalizzerà il suo portfolio su tutti e quattro i marchi - LuK, INA, FAG e Ruville - in modo ancora più mirato alle esigenze delle imprese di trasporto e degli operatori di flotta. La gamma comprende componenti e soluzioni di riparazione per la trasmissione, il motore e il telaio – massima qualità da un unico fornitore.

Tutti i prodotti per veicoli commerciali leggeri sono sviluppati con l'obiettivo di aumentare la mobilità e ridurre i costi operativi. L'attenzione è focalizzata su soluzioni di riparazione di lunga durata e costi ottimizzati, e su un portfolio di prodotti per tutti i veicoli più importanti come Ford Transit e Mercedes-Benz Sprinter. Tutto a vantaggio degli operatori di flotta, delle officine, ma anche dei rivenditori al dettaglio.

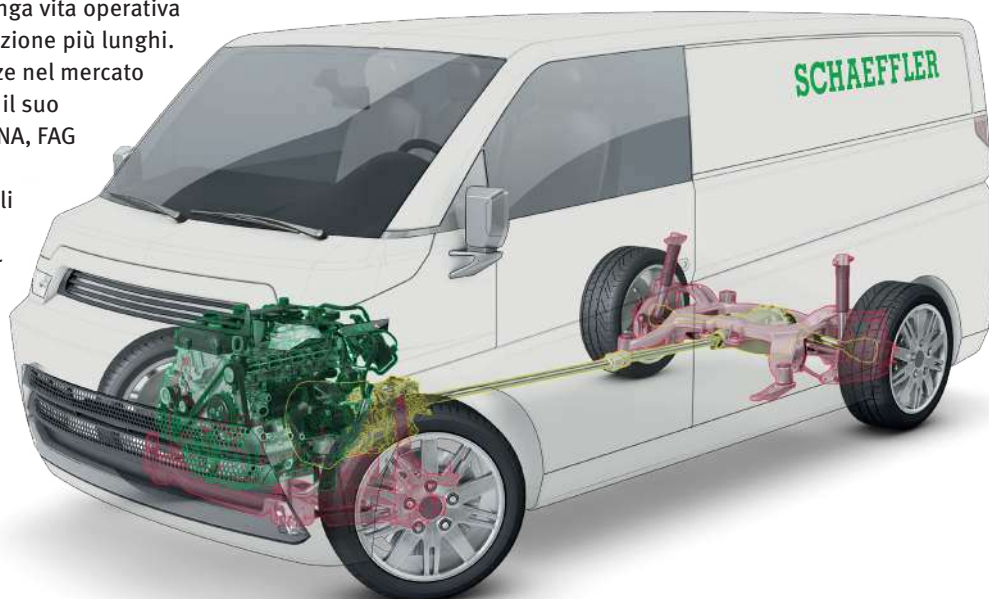

Tutto da un unico fornitore – Soluzioni di riparazione per trasmissione, motore e telaio.

Prodotti di punta Schaeffler per il mercato aftermarket

Limitatore di coppia (Impact Torque Limiter)

Maggiore longevità grazie alla protezione dal sovraccarico

I veicoli commerciali leggeri sono soggetti a carichi estremi: carico massimo fino al limite del peso totale ammesso, una trasmissione particolarmente lunga e quindi sensibile per le unità a trazione posteriore e un utilizzo caratterizzato da un'enorme pressione sui costi e sui tempi. La frequente sostituzione del guidatore e le ripetute soste e ripartenze non sono rare per i veicoli commerciali e aumentano le sollecitazioni sui mezzi.

Per limitare i picchi di coppia negli organi di trasmissione e quindi proteggerli dall'usura, Schaeffler ha sviluppato un meccanismo per la limitazione della coppia di trasmissione: il cosiddetto limitatore di coppia (Impact Torque Limiter) – una dotazione speciale del volano a doppia massa (DMF).

Quando si cerca di adattare la velocità del motore in modo particolarmente rapido alla velocità dell'albero di trasmissione si generano carichi improvvisi con valori di coppia molto più elevati della coppia massima del motore.

Tali carichi nel lungo periodo possono danneggiare il DMF e avere un effetto negativo sul motore e sugli organi di trasmissione. Nei veicoli commerciali leggeri, questi picchi di coppia sono ancora più elevati in condizioni di pieno carico.

Il limitatore di coppia permette alla flangia di scorrere momentaneamente, riducendo i carichi improvvisi negli organi di trasmissione.

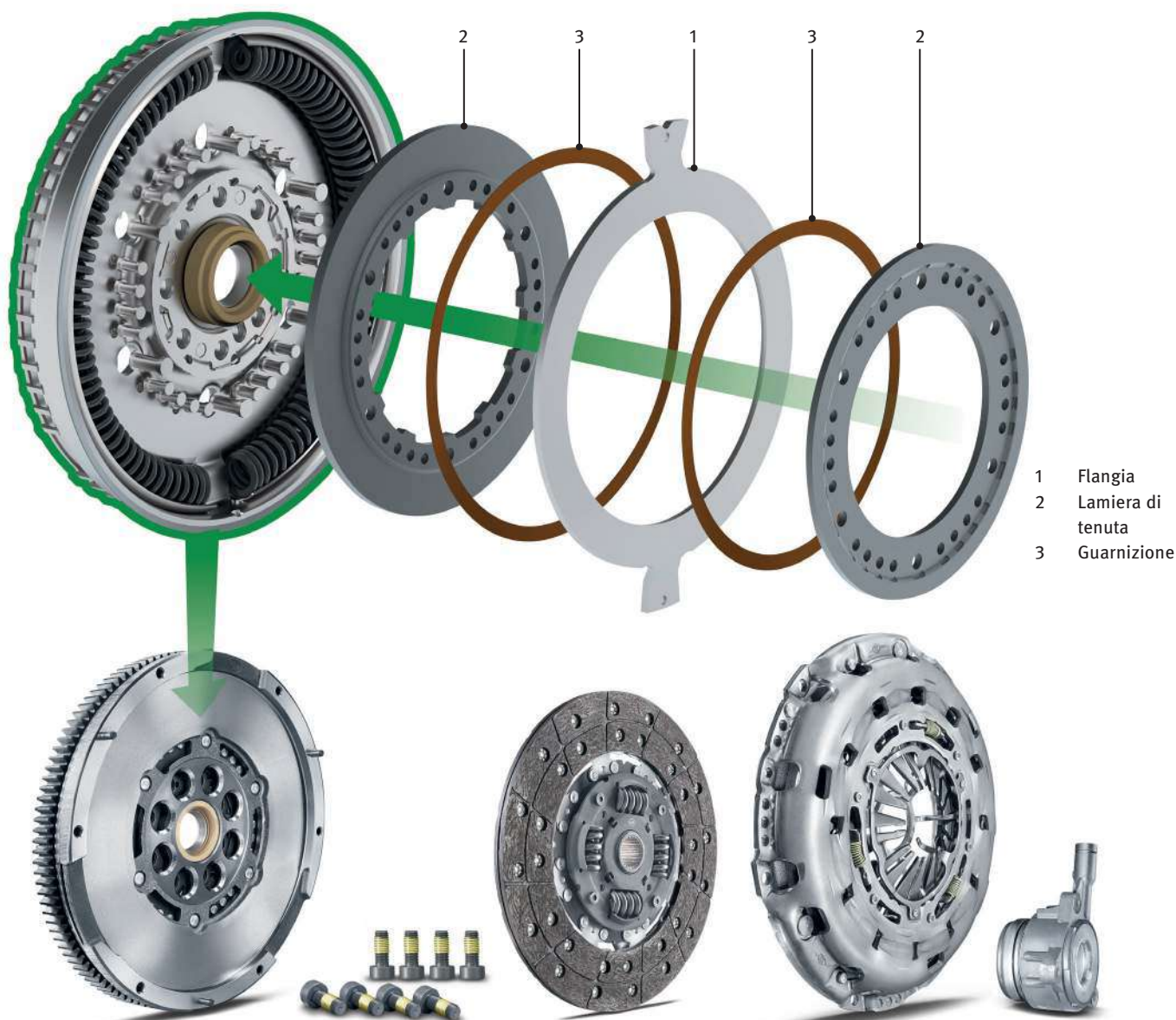

Schaeffler offre il volano a doppia massa con dispositivo anti vibrazioni specificatamente per il segmento dei veicoli commerciali leggeri, ad esempio per il Ford Transit e IVECO Daily, ed è l'unico fornitore di questo prodotto sul mercato.



Focus sugli operatori di flotta: qui non manca assolutamente nulla – LuK GearBOX

Ogni tipo di trasmissione, indipendentemente dal produttore, è soggetta all'usura in modo diverso. Nei veicoli commerciali leggeri, per i quali non è raro percorrere più di 100.000 km all'anno, l'usura si presenta prima. I carichi elevati e il comportamento di guida soggetto a frequenti variazioni sollecitano ulteriormente la trasmissione. Normalmente si comincia con danni ai cuscinetti, che sono identificabili da un rumore di sfregamento o abrasione nella trasmissione. Senza adeguate contromisure, vi è il rischio di un costoso guasto al veicolo.

La nostra soluzione per l'ottimizzazione dei costi è qui: LuK GearBOX.

Il concetto di LuK GearBOX si basa su un'analisi approfondita delle principali cause di guasto dei cambi manuali. La soluzione di riparazione comprende i singoli componenti necessari per eliminare i guasti più comuni.

Il LuK GearBOX include i cuscinetti principali, gli elementi di tenuta e altre parti soggette ad usura, che devono essere sostituiti durante una riparazione professionale, in quanto sono soggetti a forti sollecitazioni durante il funzionamento. Attrezzi speciali per un intervento di riparazione semplice completano l'offerta.



Il LuK GearBOX contiene i singoli componenti necessari per l'eliminazione di particolari cause di guasto, e include i cuscinetti principali, gli elementi di tenuta e le parti soggette ad usura per quella specifica trasmissione.

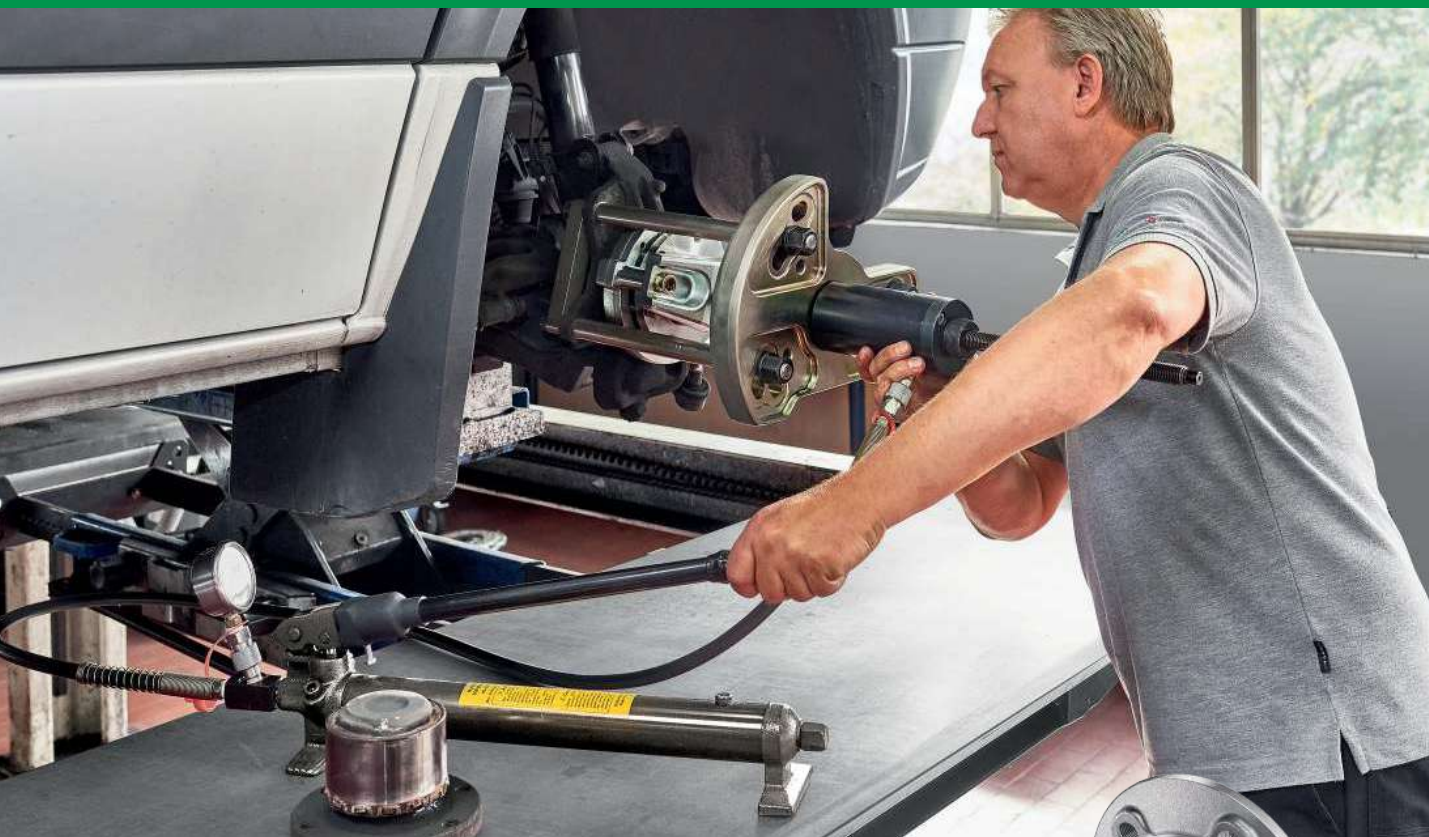

Soluzioni di riparazione FAG dei cuscinetti ruota per veicoli commerciali leggeri

Riparazione rapida dei cuscinetti ruota

La soluzione di riparazione FAG per cuscinetti ruota per i modelli Mercedes-Benz Sprinter, Vito e Volkswagen Crafter offre molti vantaggi per il cliente. Anziché sostituire l'intero fusello, Schaeffler ha sviluppato uno speciale strumento, che permette di lasciare il fusello in posizione durante la riparazione dei cuscinetti ruota. Viene sostituito solamente il cuscinetto ruota e il controllo della convergenza dopo il montaggio non è necessario.

Questo ingegnoso kit di riparazione consente alle officine di risparmiare diverse fasi di lavoro e riduce il tempo dell'intervento fino al 60% rispetto alle tradizionali riparazioni dei cuscinetti ruota.

Processi di riparazione ottimizzati significano un nuovo potenziale commerciale per le officine indipendenti: operatori di flotta e aziende di trasporti beneficiano di tempi di fermo veicolo ridotti al minimo e di una maggiore vita operativa del veicolo commerciale, il che rafforza la fidelizzazione della clientela. La base clienti esistente viene ampliata per includere i clienti aziendali e offre la possibilità di vendere ulteriori servizi di officina e pezzi di ricambio.

Sostituzione cuscinetti ruota FAG

- 713 6680 10 Mercedes Benz Sprinter/VW Crafter fino a 1850 kg di carico assiale
- 713 6680 20 Mercedes Benz Sprinter/VW Crafter a partire da 1850 kg di carico assiale
- 713 6680 50 Mercedes Benz Vito e Viano



Utensile speciale FAG

- 400 6199 10

Per il corretto smontaggio e montaggio dei cuscinetti ruota FAG è indispensabile l'utensile speciale FAG.



Gamma tiranteria

Qualità senza compromessi per i clienti più esigenti

I componenti dello sterzo e del telaio di Schaeffler sono progettati in modo intelligente e assolutamente affidabile per resistere alle sfide quotidiane del settore dei trasporti. Ogni prodotto è sottoposto ad un processo di verifica molto intenso prima di essere lanciato sul mercato. Tutti i componenti sono testati nel laboratorio di Schaeffler per quanto riguarda dimensione, funzionalità e qualità dei materiali. Inoltre, la qualità dei componenti è controllata da test effettuati da istituti indipendenti come la Rheinisch-Westfälische Technische Hochschule (RWTH) di Aquisgrana, il TÜV e il Det Norske Veritas Germanischer Lloyd (DNV GL).

Per quanto riguarda la qualità e la minore usura, la scelta dei materiali e la giusta combinazione giocano un ruolo decisivo. Un elevato livello di qualità è la priorità assoluta di Schaeffler. Perciò Schaeffler offre una garanzia di due anni senza limiti di chilometraggio per ogni componente.

Un esempio di questa qualità sono i manicotti di protezione dalla polvere a marchio Ruville. Grazie all'utilizzo di poliuretano termoplastico (es. Elastollan®) al posto del neoprene standard (CR), questo componente raggiunge una tenuta permanente del giunto - in modo da resistere molto più a lungo ad agenti quali acqua, sabbia, polvere, raggi UV o anche sostanze chimiche.

Inoltre, la robustezza riduce al minimo le possibili conseguenze di errori di montaggio e il materiale rimane il più flessibile possibile ad ogni temperatura.

















Rispetto ad altri fornitori nel mercato, per evitare la corrosione delle superfici e quindi l'indebolimento del materiale dei componenti, questi ultimi vengono galvanizzati. In questo modo si garantisce che tutti i componenti importanti per la sicurezza operino sempre in modo ottimale.



Superfici galvanizzate e l'uso del più moderno materiale per i manicotti di protezione, Elastollan® garantiscono una vita operativa maggiore.

Categoria articolo

	Perno dell'asse, corpo dell'asse	GearBOX	Kit riparazione, Cambio manuale
	Giunto assiale, Asta trasversale		Kit riparazione, Braccio tenditore cinghie poly V
	Set barre di torsione		Puleggia, generatore
	Barra di torsione		Puleggia cinghia, albero a gomito
	Set guaine parapolvere, Semiasse		Kit puleggia cin, Asse a gomito
	Supporto ammortizzatore a molla		Tendicinghia, cinghia dentata
	Set di manicotti flessibili frizione		Bilancere a dito, treno valvole
	Kit cilindro trasmettitore/secondario frizione		Set viti, Volano
	Cilindro trasmettitore frizione		Smorzatore vibrazioni, cinghia poly V
	Kit giunti, Semiasse		Smorzatore vibrazioni, cinghiadentata
	Ruota Libera Alternatore		Volano
	Generatore di impulsi, Asse a gomito		Braccio tenditore, cinghia poly V
	Cinghie trapezoidali		Braccio tenditore, cinghia dentata
	Cinghia poly V		Rullo tenditore, cinghia trapezoidale
	Set cinghia poly V		Rullo tenditore, cinghia poly V
	Catena, Azionamento pompa olio		Rullo tenditore, cinghia dentata
	Set catene, Azionamento pompa olio		Barra d'accoppiamento
	Kit frizione		Testa barra accoppiamento
	Kit frizione Pro		Stabilizzatore, Telai
	Perno di banco, Leva rullo tenditore		Asta/puntone, Stabilizzatore
	Braccio oscillante, Sospensione ruota		Kit catena di distribuzione
	Kit di montaggio, Giunto di supporto/guida		Valvola magnetica del variatore di fase
	Kit attrezzo montaggio, perno dell'asse (corpo dell'asse)		Puntone, Pompa alta pressione
	Cilindro ricevitore, Frizione		Giunto di supporto/guida
	Albero a camme		Galoppino
	Kit albero a camme		Punteria
	Variatore di fase		Pompa acqua
	Cuscinetto ruota		Pompa acqua + set cinghia poly V
	Serie cuscinetti ruota		Pompa acqua + cinghia dentata
	WheelPro – contiene 2 serie cuscinetti ruota		Set utensili, Tempi di controllo
	Kit riparazione, Corpo dell'asse		Cuscinetto volvente, cuscinetto supporto ammortizzatore a molla
	Kit riparazione, Perno dell'asse (corpo dell'asse)		Set cinghie dentate
	Kit riparazione, Supporto ammortizzatore a molla		Valvola centrale, Variatore di fase

Struttura della pagina

- a** Modello
b Anno di produzione
c Informazioni sull'utilizzo degli articoli
d Codice articolo
e N. pagina utensile speciale/ lista componenti
f Codice motore
g Informazioni sul veicolo relativamente all'articolo

a	b	c		d	e
				SCHAEFFLER	
FORD					
TRANSIT / TOURNEO CUSTOM					
2.2 TDCi CVFF; CYF4; CYFF; DRF4; DRFF; DRFG; (74-114kW) f	04.12-		SAC excl.		626 3093 33
					415 0562 10
					411 0120 10
			; A/C		532 0470 10
					532 0477 10
			; A/C		534 0308 10
			# F-554766.XX g		535 0160 10
					FB 4EPK922
			; A/C		FB 6EPK873
			1x		538 0465 10
					OILP 553 0223 10
			; 250, 260, 270, 280 290, 300, 310		Set 713 6791 20
			; 330, 350, 390, 410 470		Set 713 6791 50
			↔		915272
			↔; I STANDARD		915274
			↔		915297























































Esempio



Avete un veicolo e state cercando il pezzo di ricambio giusto - ad esempio: Ford Transit, anno di costruzione 2012, asse anteriore

- 1 Cercare l'autoveicolo nell'elenco
- 2 eventualmente considerare l'asse anteriore o altri criteri
- 3 Cercare il codice articolo









a	b	c		d	e
				SCHAEFFLER	
FORD					
TRANSIT / TOURNEO CUSTOM					
2.2 TDCi CVFF; CYF4; CYFF; DRF4; DRFF; DRFG; (74-114kW) 1	04.12-		SAC excl.		626 3093 33
					415 0562 10
					411 0120 10
			; A/C		532 0470 10
					532 0477 10
			; A/C		534 0308 10
			# F-554766.XX		535 0160 10
					FB 4EPK922
			; A/C		FB 6EPK873
			1x		538 0465 10
					OILP 553 0223 10
			; 250, 260, 270, 280 290, 300, 310 2		Set 713 6791 20 3
			; 330, 350, 390, 410 470		Set 713 6791 50
			↔		915272
			↔; I STANDARD		915274
			↔		915297

Informazioni sull'uso dell'articolo

... X	Quantità richiesta		non per prototipo asse
	Istruzioni di montaggio esterno		per riferimento tecnico
	Istruzioni di montaggio interno		Limitazione da parte del costruttore
	Istruzioni di montaggio entrambi i lati		Numero generatore
	Istruzioni di montaggio asse posteriore		Azionamento asse
	Istruzioni di montaggio asse anteriore		Codice/tipologia motore
	Istruzioni di montaggio lato trasmissione		Peso (kg)
	Istruzioni di montaggio anteriore sinistro / asse anteriore sinistro		Peso maggiorato
	Istruzioni di montaggio anteriore destro / asse anteriore destro		non per peso maggiorato
	Istruzioni di montaggio posteriore sinistro / asse posteriore sinistro		Veicoli per uso speciale
	Istruzioni di montaggio posteriore destro / asse posteriore destro		non per veicoli per uso speciale
	Istruzioni di montaggio sinistra		per numero articolo / OE Numero
	Istruzioni di montaggio destra		non per numero articolo / OE Numero
	Istruzioni di montaggio superiore		per N° telaio
	Istruzioni di montaggio inferiore		per asse oscillante
	Istruzioni di montaggio lato ruota		per asse rigido
	Istruzioni di montaggio lato frontale		per asse sterzante
	per ID trasmissione		per ammortizzatore a molla indipendente
	Gruppo motore: Generatore		per prototipo
	Gruppo motore: Rullo tenditore		non per prototipo
TURBOC	Gruppo motore: Turbocompressore	EURO 4	per norma sulle emissioni Euro 4
	Gruppo motore: Pompa dell'acqua	EURO 5	per norma sulle emissioni Euro 5
	Gruppo motore: Compressore	EURO 5	non per norma sulle emissioni Euro 5
A/C	Gruppo motore: Compressore climatizzatore	EURO 6	per norma sulle emissioni Euro 6
	Gruppo motore: Servopompa	EURO 6	non per norma sulle emissioni Euro 6
	Gruppo motore: Piastra intermedia		Numero denti anello ABS
	Gruppo motore: Albero a camme		per variante equipaggiamento
FWD	Trazione anteriore		non per variante equipaggiamento
RWD	Trazione posteriore		per numero trasmissione
4WD	Trazione integrale		non per N° trasmissione
	Dimensione cerchi (pollici)		per tipo trasmissione
	non per dimensioni cerchi (pollici)		per cambio manuale
	Prototipo asse		per numero di nervature

 SEQU	per cambio sequenziale	TSPORT	per veicoli senza telaio sportivo
 SEQU	non per cambio sequenziale	I STANDARD	per veicoli con telaio standard
 SEMI	Trasmissione: semi automatica		per veicoli con telaio rinforzato
 SEMI	Trasmissione: non per semi automatica		per veicoli senza telaio rinforzato
G5	per cambio manuale 5 marce	PTO	per veicoli con presa di potenza
G6	per cambio manuale 6 marce	PTO	per veicoli senza presa di potenza
+	solo assieme a		per presa di potenza rigida
	Forma: circolare		per / con presa di potenza
	Forma: ovale		con puleggia a ruota libera alternatore
	Diametro esterno medio (mm)		con puleggia cinghia albero motore
ABS	per veicoli con ABS		Pneumatici: con pneumatici singoli
ABS	non per veicoli con ABS		Pneumatici: con pneumatici doppi
	Torx esterno		Pneumatici: non per pneumatici doppi
	Tipo di fissaggio: fissaggio a 3 punti	OPTION	opzionalmente
LHD	Sterzo a sinistra		interasse maggiorato
RHD	Sterzo a destra		non per interasse maggiorato
A/C	per veicoli con impianto di climatizzazione		interasse ridotto
A/C	per veicoli senza impianto di climatizzazione		non per interasse ridotto
	per veicoli filtro diesel antiparticolato (DPF)		Segmento forato ABS
	per veicoli senza filtro diesel antiparticolato (DPF)		Segmento dentato ABS
	per veicoli con riscaldamento elettrico supplementare		per motori con volano a doppia massa
	per veicoli senza riscaldamento elettrico supplementare		per motori senza volano a doppia massa
	per veicoli con servosterzo		per modello per la Turchia
	per veicoli senza servosterzo		Modello non per la Turchia
	per veicoli con sterzo servotronic/servosterzo elettrico		Mozzo ruota / Diametro mozzo ruota
	per veicoli senza sterzo servotronic/servosterzo elettrico		Massa asse
	per veicoli con impianto di climatizzazione a tetto		per diametro disco freno (mm)
	per veicoli con ammortizzatore tensionatore cinghia		Asta di accoppiamento
	per veicoli senza ammortizzatore tensionatore cinghia		Tipo di giunto: giunto tripode
START/STOP	per veicoli con funzione start&stop		Tipo di giunto: Giunto omocinetico
START/STOP	per veicoli senza funzione start&stop		Istruzioni per montaggio: braccio trasversale
	per veicoli con stabilizzatore		Lato montaggio: barra di torsione
I SPORT	per veicoli con telaio sportivo		per veicoli con stabilizzatore rinforzato

Informazioni sull'uso dell'articolo

	Costruzione speciale		Guarnizione
	per veicoli con generatore di avviamento		Guarnizione ad anello per albero motore
	per veicoli senza generatore di avviamento		Ruota dentata
	per produttore volano LuK		Kit completo
	per produttore volano Sachs		Per pezzi singoli vedi la lista pezzi
	per produttore volano Valeo		

Abbreviazioni

SAC	Frizione autoregistrante	ORGA	Numero Orga
DC	Corrente continua	VERSION	Versione
BS	Contralbero	VET	Numero VET
HYDP	Pompa idraulica	ACC	Climatizzatore automatico
AirComp	Compressore aria	HA	Supporto
VP	Pompa vuoto	V	Tensione (Volt)
OILP	Pompa olio	incl.	Incluso
MY	Anno modello	excl.	Escluso
INJP	Pompa iniettore	+	con
HD	Rinforzato	—	senza



Il marchio di servizio per tutti i meccanici.

Con il brand REPERT offriamo un pacchetto completo di servizi per i prodotti e le soluzioni di riparazione LuK, INA, FAG e Ruville. Vi serve un'informazione dettagliata o una diagnosi del guasto? Siete alla ricerca di un utensile particolare che semplifichi il lavoro quotidiano? Portale online, hotline di assistenza, video e istruzioni di installazione, seminari ed eventi: tutti questi servizi fanno capo ad un'unica struttura.

LAVORARE

- Gamma prodotti
- Catalogo TECDOC
- Bollettini tecnici
- Diagnosi dei danni
- Manuali d'officina TECRMI
- Programma fedeltà

AGGIORNARSI

- Formazione
- Dimostrazioni tecniche
- Video di montaggio

INFORMARSI

- Calendario eventi
- Rivista REPERT
- Novità su prodotti, servizi e molto altro ancora

Registrarsi è gratis e richiede solo pochi click: www.repxpert.it

TecDoc



Aggiornamenti del catalogo? D'ora in avanti niente più problemi!

Approfittate delle possibilità che vi offre il DVD TecDoc. Il DVD vi mette a disposizione ogni tre mesi l'aggiornamento dei dati del catalogo per la vostra attività.

Potete ordinare a:

TecAlliance GmbH
Arnikaweg 3
D-51109 Colonia
Tel. +49 (0) 221/66 00-112
Fax +49 (0) 221/66 00-100
e-mail: tecdoc@tecalliance.net

Elaborazione on line della garanzia attraverso TecWarranty





Il marchio di servizio per tutti i meccanici.

Con il brand REPERT offriamo un pacchetto completo di servizi per i prodotti e le soluzioni di riparazione LuK, INA, FAG e Ruville. Vi serve un'informazione dettagliata o una diagnosi del guasto? Siete alla ricerca di un utensile particolare che semplifichi il lavoro quotidiano? Portale online, hotline di assistenza, video e istruzioni di installazione, seminari ed eventi: tutti questi servizi fanno capo ad un'unica struttura.

LAVORARE

- Gamma prodotti
- Catalogo TECDOC
- Bollettini tecnici
- Diagnosi dei danni
- Manuali d'officina TECRMI
- Programma fedeltà

AGGIORNARSI

- Formazione
- Dimostrazioni tecniche
- Video di montaggio

INFORMARSI

- Calendario eventi
- Rivista REPERT
- Novità su prodotti, servizi e molto altro ancora

Registrarsi è gratis e richiede solo pochi click: www.repxpert.it

TecDoc



Aggiornamenti del catalogo? D'ora in avanti niente più problemi!

Approfittate delle possibilità che vi offre il DVD TecDoc. Il DVD vi mette a disposizione ogni tre mesi l'aggiornamento dei dati del catalogo per la vostra attività.

Potete ordinare a:

TecAlliance GmbH
Arnikaweg 3
D-51109 Colonia
Tel. +49 (0) 221/66 00-112
Fax +49 (0) 221/66 00-100
e-mail: tecdoc@tecalliance.net

Elaborazione on line della garanzia attraverso TecWarranty





Il marchio di servizio per tutti i meccanici.

Con il brand REPERT offriamo un pacchetto completo di servizi per i prodotti e le soluzioni di riparazione LuK, INA, FAG e Ruville. Vi serve un'informazione dettagliata o una diagnosi del guasto? Siete alla ricerca di un utensile particolare che semplifichi il lavoro quotidiano? Portale online, hotline di assistenza, video e istruzioni di installazione, seminari ed eventi: tutti questi servizi fanno capo ad un'unica struttura.

LAVORARE

- Gamma prodotti
- Catalogo TECDOC
- Bollettini tecnici
- Diagnosi dei danni
- Manuali d'officina TECRMI
- Programma fedeltà

AGGIORNARSI

- Formazione
- Dimostrazioni tecniche
- Video di montaggio

INFORMARSI

- Calendario eventi
- Rivista REPERT
- Novità su prodotti, servizi e molto altro ancora

Registrarsi è gratis e richiede solo pochi click: www.repxpert.it

TecDoc



Aggiornamenti del catalogo? D'ora in avanti niente più problemi!

Approfittate delle possibilità che vi offre il DVD TecDoc. Il DVD vi mette a disposizione ogni tre mesi l'aggiornamento dei dati del catalogo per la vostra attività.

Potete ordinare a:

TecAlliance GmbH
Arnikaweg 3
D-51109 Colonia
Tel. +49 (0) 221/66 00-112
Fax +49 (0) 221/66 00-100
e-mail: tecdoc@tecalliance.net

Elaborazione on line della garanzia attraverso TecWarranty





Samochody dostawcze: rynek wzrostu	84
Produkty flagowe Schaeffler dla rynku motoryzacyjnych części zamiennych	86
Grupy artykułów	92
Struktura strony	93
Informacje dot. wykorzystania artykułów	94

CITROËN	114
BERLINGO	114
JUMPER	127
FIAT	139
DOBLO	139
DUCATO	151
FIORINO	176
SCUDO	178
TALENTO	182
FORD	183
TRANSIT	183
FUSO (MITSUBISHI)	216
CANTER	216
GAZ	216
GAZELLE	216
HYUNDAI	217
H-1	217
H200	221
IVECO	222
DAILY	222

MAN	289
TGE	289
MERCEDES-BENZ	290
SPRINTER	290
VITO	357
MITSUBISHI	375
CANTER	375
L200	376
L300	376
NISSAN	376
CABSTAR	376
INTERSTAR	377
NT400	386
NV200	386
NV300	388
NV400	390
PRIMASTAR	401
OPEL	410
COMBO	410
MOVANO	418

VIVARO	444
PEUGEOT	463
BOXER	463
EXPERT	474
PARTNER	481
RENAULT	495
KANGOO	495
MASTER	508
TRAFIC	543
TOYOTA	563
HIACE	563
VAUXHALL	569
COMBO	569
MOVANO	576
VIVARO	597
VW	615
CADDY	615
CRAFTER	635
LT	641
TRANSPORTER	642

 Inhalt ... 3

 Content ... 19

 Contenu ... 35

 Índice ... 51

 Indice ... 67

 Содержание ... 99

Listy numerycznej	678
-------------------	-----

Kopiowanie tego katalogu, zarówno w całości lub we fragmentach bez uprzedniej pisemnej zgody jest zabronione. Schaeffler nie ponosi odpowiedzialności w związku z błędami

mogącymi pojawić się w niniejszym katalogu. Zastrzegamy sobie prawo do wprowadzania zmian, dotyczących zarówno treści, jak i struktury katalogu.

Samochody dostawcze: rynek wzrostu

Rozwijająca się branża

Dziś nie jesteśmy w stanie sobie wyobrazić naszego życia codziennego bez samochodów dostawczych. Transportery wszelkiego rodzaju są popularne jak nigdy dotąd. Z prognozowanym wzrostem rynku na poziomie ośmiu procent rocznie są najszybciej rozwijającym się segmentem pojazdów i podstawą transportu wykorzystywanego komercyjnie. Tendencja mocno wzrostowa, gdyż popularność handlu online dynamicznie wzrasta, a szybsze dostawy pod same drzwi są obecnie bardzo popularne.

Na odcinku od centrum dystrybucji do odbiorcy, zwanym również „last mile“, ma miejsce największy wzrost na tak zwanym rynku KEP (Kurier, Ekspres i Paczka): Zgodnie z prognozami wielkość paczek ulegnie zmniejszeniu, ilość paczek wzrośnie ponad dwukrotnie, a dostawy ekspresowe tego samego dnia staną się rzeczywistością. W efekcie wzrośnie popyt na samochody dostawcze, które będą w stanie szybko i sprawnie dostarczyć towary. Ważne kryterium, w szczególności w obszarach miejskich, gdyż już w roku 2025 jedna czwarta całej światowej populacji będzie mieszkać w 600 największych miastach i generować ponad połowę światowej produkcji dóbr i usług.

Zauważanie potencjałów

Przeżywająca boom branża aut dostawczych stwarza ogromny potencjał dla niezależnych warsztatów i tworzy nowe modele biznesowe. Pojazdy użytkowe w ruchu miejskim muszą być szybkie i zdolne do przystosowania się, dodatkowo muszą osiągać wysokie przebiegi, transportować ciężkie ładunki i działać niezawodnie częściowo w najtrudniejszych warunkach. To właśnie pojazdy firm logistycznych, kurierów, zakładów rzemieślniczych i handlu detalicznego zaliczają dziennie do 120 przystanków.

Również przebiegi sięgające ponad 100 000 kilometrów rocznie nie są rzadkością, i to pod ciągłą presją czasu. W takich sytuacjach duże zużycie i naprawy są nieuniknione.

Niezależne warsztaty mogą uczestniczyć w tym stale rozwijającym się rynku, mając w ofercie nowe usługi serwisowe. Schaeffler oferuje kompleksowe rozwiązania naprawcze przeniesienia napędu, elementów silnika, łożysk kół i zawieszania - co efektywnie skraca czas przestoju auta dostawczego w warsztacie.

Sprzedaż dodatkowych usług warsztatowych i części zamiennych skutkuje większym obciążeniem warsztatu i umożliwia zaprezentowanie swoich umiejętności w zakresie naprawy aut dostawczych. Różnorodność modeli w obszarze samochodów osobowych jest bardzo duża, ale w przypadku aut dostawczych jest prościej. Najpopularniejsze to: Ford Transit, Mercedes Benz Sprinter, Fiat Ducato i VW Transporter. Co dziesiąty pojazd w Europie to Ford Transit, następne w kolejności to Mercedes-Benz Sprinter i VW Transporter.

W szczególności dla warsztatów samochodów ciężarowych powstają nowe możliwości biznesowe na znanych warunkach ramowych: Dla klientów komercyjnych liczy się szybka i niezawodna naprawa, aby móc szybko ponownie eksploatować pojazd. Przystój kosztuje - może to być nawet 1000 euro za każdy dzień. Tym samym koszty utrzymania stały się kluczowe dla osiągnięcia przewagi nad konkurencją w branży, dla której charakterystyczna jest presja czasu i kosztów.



Branża transportowa przeżywa boom. Silny wzrost handlu online napędza usługi kurierskie, ekspresowe i przesyłkowe, a tym samym również popyt na samochody dostawcze.



Samochody dostawcze mają coraz większy udział w rynku i każdy warsztat samochodów ciężarowych i osobowych powinien dołączyć ten zakres usług do swojej oferty.

Portfolio obejmujące wiele marek w zakresie pojazdów użytkowanych komercyjnie

Przez całą dobę, siedem dni w tygodniu: Eksploatowane komercyjnie pojazdy takie jak wywrotki, platformy, autobusy, czy samochody z nadwoziem pełnym, wymagają codziennie najwyższej gotowości eksploatacyjnej w najtrudniejszych warunkach. Ulegają one przy tym większemu zużyciu i muszą być naprawiane częściej niż samochody osobowe.

Schaeffler dzięki swoim łatwym i szybkim w montażu rozwiązaniom naprawczym wychodzi naprzeciw tym oczekiwaniom. Oprócz kosztów utrzymania pojazdu decydujące są przede wszystkim czasy przestoju spowodowane naprawami. Im łatwiejsze w montażu jest dane rozwiązanie, tym szybciej pojazd wróci na drogę. Wysokiej jakości produkty o długiej żywotności zapewniają dodatkowo dłuższe interwały serwisowe. Schaeffler dostrzega te specjalne oczekiwania i ukierunkowuje swoje portfolio za pomocą wszystkich czterech marek – LuK, INA, FAG i Ruville – jeszcze mocniej na potrzeby klientów z zakresu przedsiębiorstw transportowych i operatorów flot pojazdów. Asortyment obejmuje podzespoły i rozwiązania w zakresie napraw napędu, silnika i zawieszenia – najwyższej jakości, wszystko z jednego źródła.

Wszystkie produkty do samochodów dostawczych są produkowane po to, aby zwiększyć mobilność i zmniejszyć koszty eksploatacyjne. Celem jest stworzenie i rozwijanie trwałych i optymalizujących koszty rozwiązań w zakresie napraw oraz portfolio obejmującego wiele marek najważniejszych pojazdów, takich jak Ford Transit i Mercedes-Benz Sprinter. Jest to korzystne w takim samym stopniu dla zarządców flot, operatorów pojazdów, warsztatów, jak również hurtowni motoryzacyjnych.

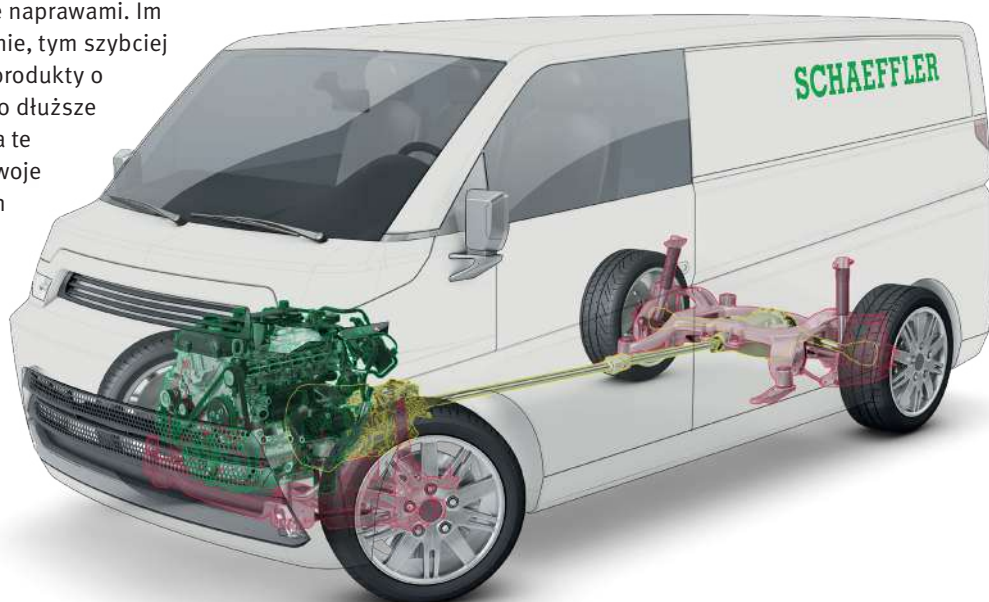

Wszystko z jednego źródła – rozwiązania w zakresie napraw układu napędu, silnika i zawieszenia.

Produkty flagowe Schaeffler dla rynku motoryzacyjnych części zamiennych

Sprzęgło zrywne w DKZ

Dłuższa żywotność dzięki ochronie przeciążeniowej

Samochody dostawcze podlegają ekstremalnym obciążeniom: maksymalne załadowanie do granic dopuszczalnej masy całkowitej, szczególnie długi, a tym samym wrażliwy układ przeniesienia napędu w przypadku pojazdów z napędem na tył oraz styl jazdy wymuszany ogromną presją kosztów i czasu w branży transportowej. Częsta zmiana kierowców oraz tryb pracy Stop-and-go nie są rzadkością w przypadku pojazdów dostawczych. Zwiększa to dodatkowo obciążenie.

Aby chronić układ przeniesienia napędu przed przeciążeniem, a tym samym przed przedwczesną awarią pojazdu, Schaeffler opracował mechanizm zabezpieczający układ napędowy przed szczytowymi skokami momentu obrotowego: Tak zwane sprzęgło zrywne – wyposażenie dodatkowe dwumasowego koła zamachowego (DKZ).

Podczas próby szczególnie szybkiego dopasowania prędkości obrotowej silnika do prędkości obrotowej wału wejściowego skrzyni biegów powstają uderzeniowe obciążenia szczytowe o krótkotrwałych wartościach momentu obrotowego wielokrotnie większych niż maksymalny moment obrotowy silnika.

Takie „uderzenia“ na dłuższą metę mogą uszkodzić DKZ i mieć negatywny wpływ na silnik i układ przeniesienia napędu.

W przypadku lekkich pojazdów użytkowych te momenty szczytowe są jeszcze wyższe przy pełnym załadowaniu.

Sprzęgło zrywne umożliwia krótkotrwałe prześlizgnięcie się kołnierza, dzięki czemu zredukowane są uderzeniowe obciążenia szczytowe w układzie przeniesienia napędu.

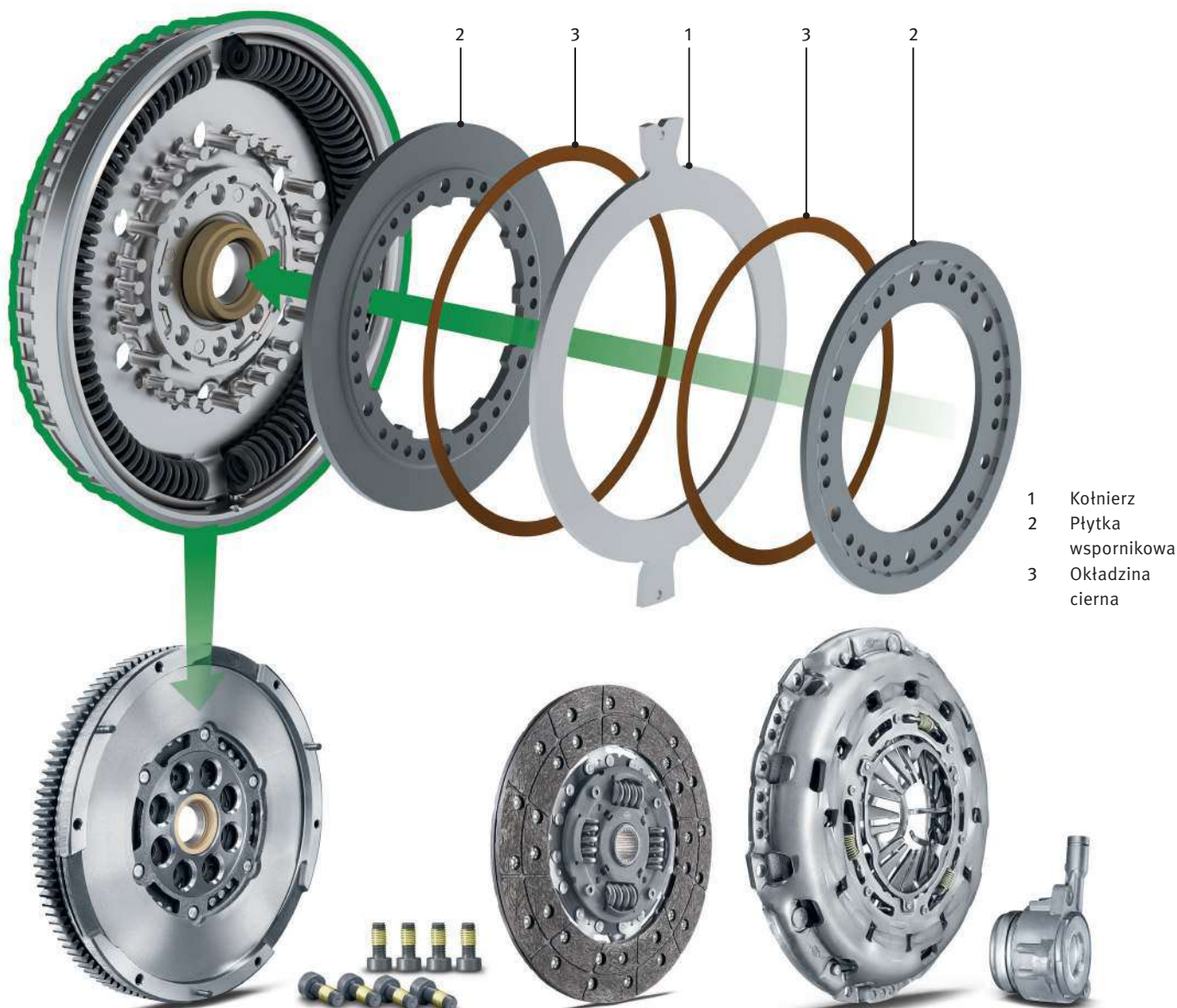

Schaeffler jako jedyny na rynku ma w swojej ofercie dwumasowe koła zamachowe z dodatkowym zabezpieczeniem układu napędowego (sprzęgło zrywne) do takich aut jak np. Ford Transit lub IVECO Daily.



Operatorzy flot w centrum zainteresowania: Tutaj absolutnie niczego nie brakuje – LuK GearBOX

Skrzynia biegów każdego typu – nieważne jakiego producenta – wykazuje indywidualne zużycie. Samochody dostawcze, w przypadku których przebiegi przekraczające 100 000 rocznie nie są rzadkością, wykazują zwiększone zużycie odpowiednio szybciej. Częste załadunki i często zmieniający się styl jazdy dodatkowo obciążają skrzynię biegów. Z reguły zaczyna się od uszkodzenia łożyska, uwidaczniającego się przez odgłos szumu lub szorowania dochodzący ze skrzyni biegów. Bez zastosowania odpowiednich środków zaradczych wzrasta ryzyko kosztownej awarii pojazdu.

Naszym rozwiązaniem tego problemu jest: LuK GearBOX.

Koncepcja zestawu LuK GearBOX bazuje na intensywnej analizie głównych przyczyn awarii skrzyń biegów. Rozwiązanie w zakresie naprawy obejmuje indywidualne podzespoły do usuwania przyczyn awarii.

W skład zestawu LuK GearBOX wchodzi najważniejsze łożyska, elementy uszczelniające i inne części które ulegają zużyciu, a które należy wymienić w ramach profesjonalnej naprawy, ponieważ podczas eksploatacji podlegają dużym obciążeniom. Ofertę dopełniają narzędzia specjalistyczne umożliwiające prostą naprawę.



LuK GearBOX zawiera dedykowane podzespoły do usuwania wszystkich możliwych przyczyn awarii, m.in. najważniejsze łożyska, elementy uszczelniające i części eksploatacyjne.

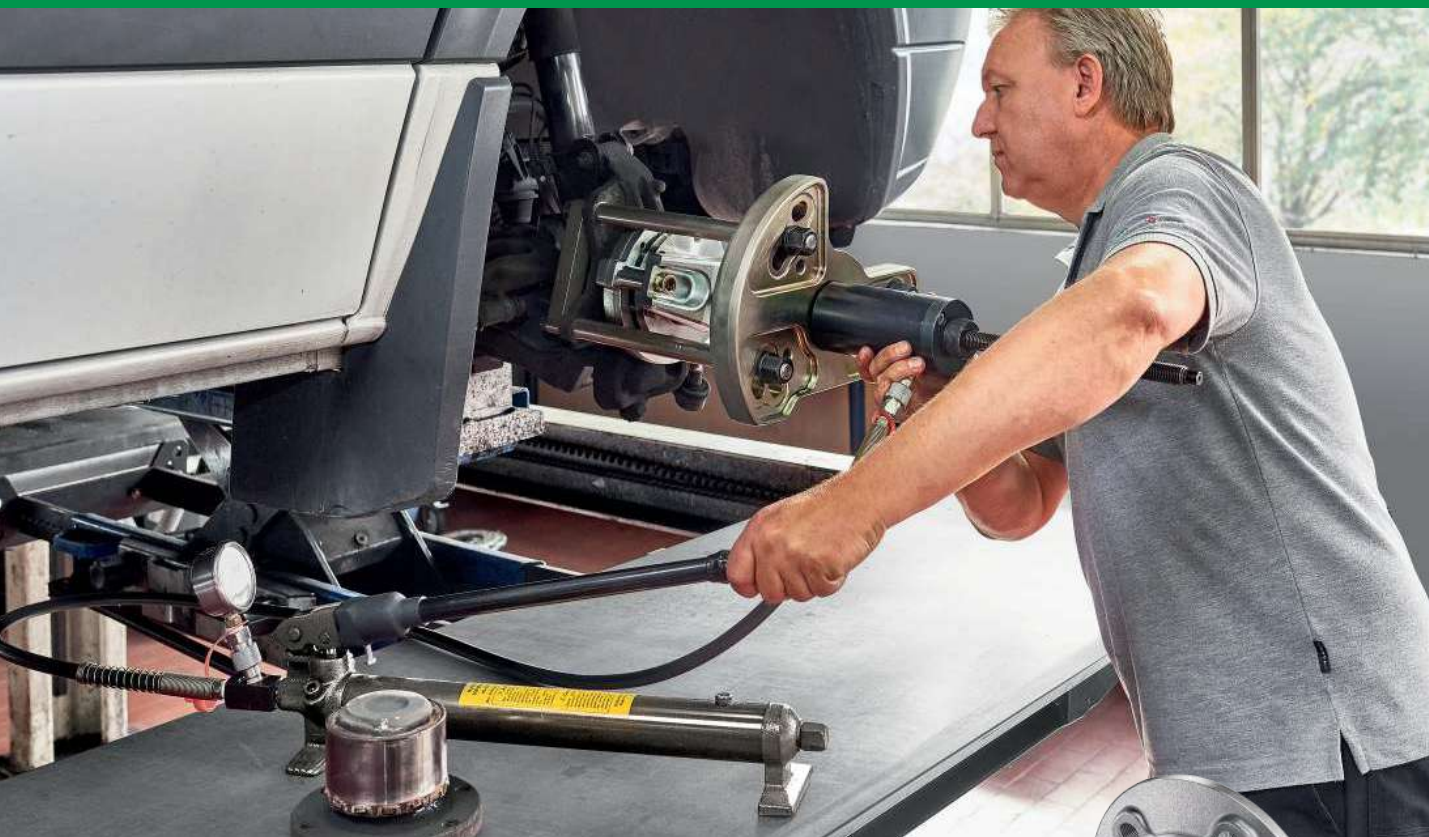

Łożysko koła FAG-Rozwiązanie w zakresie naprawy samochodów dostawczych

Szybka naprawa łożyska koła

Optymalną korzyść dla klienta oferuje rozwiązanie łożyska koła FAG do modeli Mercedes-Benz Sprinter, Viano, Vito i Volkswagen Crafter. Zamiast wymieniać kompletną zwrotnicę koła, Schaeffler opracował specjalne narzędzie, dzięki któremu zwrotnica koła podczas naprawy łożyska pozostaje w pojeździe. Wymienione zostaje tylko łożysko i nie ma konieczności przeprowadzenia pomiaru geometrii kół.

Ten pomysłowy proces naprawczy zaoszczędza warsztatom kilka kroków roboczych i ogranicza konieczny czas pracy w stosunku do konwencjonalnych napraw łożysk kół nawet o 60 procent.

Zoptymalizowane procesy naprawcze tego rodzaju oznaczają dla niezależnego warsztatu nowe potencjały: Operatorzy flot i przedsiębiorstwa transportowe profitują ze zminimalizowanych czasów przestojów i wydłużonego czasu eksploatacji, co wzmacnia przywiązanie klienta. Dotychczasowa baza poszerza się o klientów komercyjnych i stwarza nowe możliwości sprzedaży dodatkowych usług warsztatowych i części zamiennych.

Zestawy łożysk FAG

- 713 6680 10
Mercedes Benz Sprinter/VW Crafter do 1850 kg nacisku na oś
- 713 6680 20
Mercedes Benz Sprinter/VW Crafter od 1850 kg nacisku na oś
- 713 6680 50 Mercedes Benz Vito i Viano



Narzędzie specjalne FAG

- 400 6199 10

Narzędzie specjalne FAG jest niezbędne do prawidłowego demontażu i montażu łożysk kół FAG.



Części układu kierowniczego i zawieszenia

Jakość która sprosta najwyższym wymaganiom

Aby sprostać codziennym wyzwaniom w branży transportowej, części układu kierowniczego i zawieszenia Schaeffler zostały zaprojektowane w sposób innowacyjny i są absolutnie niezawodne. Każdy produkt przechodzi szczególnie intensywny proces kontroli, zanim zostanie wprowadzony na rynek. Laboratorium Schaeffler, wyposażone w najnowsze urządzenia badawcze, zajmuje się kontrolą pod względem wymiarów, budowy, poprawności działania i składu materiałowego wszystkich części. Dodatkowo jakość części konstrukcyjnych kontrolowana jest w ramach badań przeprowadzanych przez niezależne instytuty, jak Rheinisch-Westfälische Technische Hochschule (RWTH) Aachen, TÜV oraz Det Norske Veritas Germanische Lloyd (DNV GL).

Pod względem jakości i bezawaryjnej eksploatacji miarodajną rolę odgrywa prawidłowy dobór i połączenie materiałów. Dlatego wysoki poziom jakości jest główną zasadą w Schaeffler. Dwa lata gwarancji bez ograniczenia kilometrowego na każdą część to dla Schaeffler oczywistość.

Przykładem tego zapewnienia jakości są pierścienie uszczelniające Ruville chroniące przed kurzem. Dzięki wykorzystaniu termoplastycznego poliuretanu (np. Elastollan(R)) zamiast zwyczajowego neoprenu (CR) osiągnięte zostało trwałe uszczelnienie przegubu – w ten sposób jest on dłużej odporny na oddziaływanie wody, piasku, pyłu, promieni UV czy nawet chemikaliów.

Dodatkowo, wytrzymała konstrukcja minimalizuje możliwe skutki błędów podczas montażu, a materiał pozostaje elastyczny nawet w dużym zakresie temperatur.



Aby zapobiec podchodzeniu powierzchni rdzą, a tym samym osłabieniu materiału części konstrukcyjnych, są one w odróżnieniu od innych ofert na rynku, dodatkowo galwanizowane. W ten sposób zostaje zagwarantowane optymalne działanie wszystkich części istotnych pod względem bezpieczeństwa.



Galwanizowanie powierzchni i wykorzystanie nowoczesnego materiału na pierścienie uszczelniające (np. Elastollan(R)) zapewniają wydłużoną żywotność.

Grupy artykułów

	Czop osi, korpus osi	GearBOX	Zestaw naprawczy skrzyni biegów
	Przegub, drążek kierowniczy		Zestaw naprawczy napinacza paska
	Zestaw drążków skrętnych		Koło pasowe alternatora
	Drążek skrętny		Koło pasowe wału korbowego
	Zestaw drążka kierowniczego		Zestaw koła pasowego wału korbowego
	Łożysko kolumny McPhersona		Napinacz paska rozrzędu
	Zestaw mocowań		Dźwignienka zaworowa
	Zestaw pompy i wysprzęglika		Zestaw śrub koła zamachowego
	Pompa sprzęgła, sprzęgło		Tłumik drgań paska wielorowkowego
	Zestaw naprawczy pólوسی		Tłumik drgań paska rozrzędu
	Sprzęgiełko alternatora		Koło zamachowe
	Enkoder pólوسی		Ramię napinające, pasek wielorowkowy
	Pasek klinowy		Ramię napinające, pasek rozrzędu
	Paskek wielorowkowy		Rolka napinacza, pasek klinowy
	Zestaw paska wielorowkowego		Rolka napinacza, pasek wielorowkowy
	łańcuch, napęd pompy oleju		Rolka napinacza, pasek rozrzędu
	Zestaw łańcucha, napęd pompy oleju		Drążek kierowniczy
	Zestaw sprzęgła		Końcówka drążka kierowniczego
	Zestaw sprzęgła z wysprzęglikiem		Stabilizator
	Czop łożyska, dźwignia napinacza koła pasowego		Łącznik stabilizatora
	Wahacz, zawieszenie koła		Zestaw łańcucha rozrzędu
	Zestaw montażowy, przegub mocujący / prowadzący		Zawór regulatora zmiennych faz rozrzędu
	Zestaw narzędzi montażowych, czop osi (korpus osi)		Popychacz zaworowy mechaniczny
	Wysprzęglik		Przegub mocujący / prowadzący
	Wał rozrzędu		Rolka prowadząca
	Zestaw wału rozrzędu		Popychacz zaworowy hydrauliczny
	Regulator zmiennych faz rozrzędu		Pompa wody
	Łożysko koła		Zestaw paska wielorowkowego z pompą wody
	Zestaw naprawczy łożyska koła		Zestaw paska rozrzędu z pompą wody
	Zestaw naprawczy łożyska - oś		Zestaw narzędzi, układy rozrzędu
	Zestaw naprawczy, korpus osi		Łożysko toczne, łożysko kolumny McPhersona
	Zestaw naprawczy, czop osi (korpus osi)		Zestaw paska rozrzędu
	Zestaw naprawczy, łożysko kolumny McPhersona		Zawór główny

Struktura strony

- a** Model
- b** Rok produkcji
- c** Informacje dot. wykorzystania artykułów
- d** Numer / grupa artykułów
- e** Numer strony dla listy numerycznej / zestawienia materiałowego
- f** Kod silnika
- g** Informacje dot. pojazdu dla danego artykułu

a	b	c	d	e
			SCHAEFFLER	
FORD				
TRANSIT / TOURNEO CUSTOM				
2.2 TDCi CVFF; CYF4; CYFF; DRF4; DRFF; DRFG; (74-114kW) f	04.12-	SAC excl.	626 3093 33 415 0562 10 411 0120 10 532 0470 10 532 0477 10 534 0308 10 535 0160 10 FB 4EPK922 FB 6EPK873 538 0465 10 OILP 553 0223 10	
		A/C A/C A/C # F-554766.XX g A/C 1x	Set 713 6791 20 Set 713 6791 50 Set 713 6791 60	
		FAG 250, 260, 270, 280 290, 300, 310 330, 350, 390, 410 470	Set 713 6791 50 Set 713 6791 60	
		RUVILLE ↔ ↔; I STANDARD ↔	915272 915274 915297	

Przykład

Dla danego pojazdu poszukiwana jest odpowiednia część zamienna - przykład: Ford Transit, rok produkcji 2012, przednia oś

- 1** Wyszukać pojazd w katalogu
- 2** Ewent. uwzględnić oś przednią lub inne kryteria
- 3** Wyszukać numer artykułu

a	b	c	d	e
			SCHAEFFLER	
FORD				
TRANSIT / TOURNEO CUSTOM				
2.2 TDCi CVFF; CYF4; CYFF; DRF4; DRFF; DRFG; (74-114kW) 1	04.12-	SAC excl.	626 3093 33 415 0562 10 411 0120 10 532 0470 10 532 0477 10 534 0308 10 535 0160 10 FB 4EPK922 FB 6EPK873 538 0465 10 OILP 553 0223 10	
		A/C A/C A/C # F-554766.XX A/C 1x	Set 713 6791 20 3 Set 713 6791 50 Set 713 6791 60	
		FAG 250, 260, 270, 280 290, 300, 310 2 330, 350, 390, 410 470	Set 713 6791 50 Set 713 6791 60	
		RUVILLE ↔ ↔; I STANDARD ↔	915272 915274 915297	

Informacje dot. wykorzystania artykułów

... X	Potrzebna ilość	BM	Nie dla wzorów konstrukcyjnych osi
	Strona montażu zewnątrz		Dla numeru producenta
	Strona montażu wewnątrz		Ograniczenie producenta
	Strona montażu obustronnie		Numer alternatora
	Strona montażu oś tylna		Wersja osiowa
	Strona montażu oś przednia		Kod / typ silnika
	Strona montażu od skrzyni biegów		Obciążenie dopuszczalne (kg)
	Strona montażu przód po lewej / oś przednia po lewej		Zwiększone obciążenie dopuszczalne
	Strona montażu przód po prawej / oś przednia po prawej		Nie dla zwiększonego obciążenia dopuszczalnego
	Strona montażu tył po lewej / oś tylna po lewej		Pojazd specjalny
	Strona montażu tył po prawej / oś tylna po prawej		Nie dla pojazdów specjalnych
	Strona montażu po lewej	#	Dla numeru artykułu / numeru OE
	Strona montażu po prawej	#	Nie dla numeru artykułu / numeru OE
	Strona montażu na górze		Dla numeru podwozia
	Strona montażu na dole		Dla przegubowego mostu pędnego
	Strona montażu od koła		Dla stałego mostu pędnego
	Strona montażu od czoła		Dla osi skrętnej
	Dla ID skrzyni biegów		Dla niezależnego zawieszenia kół
	Elementy napędzane: Alternator		Dla wzorów konstrukcyjnych
	Elementy napędzane: Napinacz		Nie dla wzorów konstrukcyjnych
TURBOC	Elementy napędzane: Turbosprężarka	EURO 4	Dla normy spalinowej Euro 4
	Elementy napędzane: Pompa wodna	EURO 5	Dla normy spalinowej Euro 5
	Elementy napędzane: Wentylator	EURO 5	Nie dla normy spalinowej Euro 5
A/C	Elementy napędzane: Sprężarka klimatyzacji	EURO 6	Dla normy spalinowej Euro 6
	Elementy napędzane: Pompa wspomagania	EURO 6	Nie dla normy spalinowej Euro 6
	Elementy napędzane: Tarcza pośrednia		Liczba zębów pierścienia ABS
	Elementy napędzane: Wał rozrządu		Dla wariantu wyposażenia
FWD	Napęd na przednią oś		Nie dla wariantu wyposażenia
RWD	Napęd na tylną oś		Dla numeru skrzyni biegów
4WD	Napęd na cztery koła		Nie dla numeru skrzyni biegów
	Rozmiar obręczy koła (cale)		Dla typu skrzyni biegów
	Nie dla rozmiaru obręczy koła (cale)		Dla manualnej skrzyni biegów
BM	Wzór konstrukcyjny osi		Dla liczby rowków

	Dla sekwencyjnej skrzyni biegów		Dla pojazdów bez podwozia sportowego
	Nie dla sekwencyjnej skrzyni biegów		Dla pojazdów ze standardowym podwoziem
	Skrzynia biegów: półautomatyczna		Dla pojazdów z wzmocnionym podwoziem
	Skrzynia biegów: nie dla półautomatycznej		Dla pojazdów bez wzmocnionego podwozia
G5	Dla pięciobiegowej manualnej skrzyni biegów	PTO	Dla pojazdów z napędem dodatkowym
G6	Dla sześciobiegowej manualnej skrzyni biegów		Dla pojazdów bez napędu dodatkowego
+	Tylko w połączeniu z		Dla stałego napędu dodatkowego
	Kształt: okrągły		Dla / z napędem dodatkowym
	Kształt: owalny		Z kołem pasowym sprzęgła jednokierunkowego
	Średnica zewnętrzna (mm)		Z kołem pasowym wału korbowego
ABS	Dla pojazdów z ABS		Ogumienie: z pojedynczym ogumieniem
	Nie dla pojazdów z ABS		Ogumienie: z podwójnym ogumieniem
	Torx zewnętrzny		Ogumienie: nie dla podwójnego ogumienia
	Rodzaj ogumienia: mocowanie trzypunktowe	OPTION	do wyboru
LHD	Kierownica lewostronna		Wydłużony rozstaw osi
RHD	Kierownica prawostronna		Nie dla wydłużonego rozstawu osi
A/C	Dla pojazdów z klimatyzacją		Skrócony rozstaw osi
	Dla pojazdów bez klimatyzacji		Nie dla skróconego rozstawu osi
	Dla pojazdów z filtrem cząstek stałych diesla (DPF)		Segment otworowy ABS
	Dla pojazdów bez filtra cząstek stałych diesla (DPF)		Segment zębaty ABS
	Dla pojazdów z elektr. ogrzewaniem dodatkowym		Dla silników z dwumasowym kołem zamachowym
	Dla pojazdów bez elektr. ogrzewania dodatkowego		Dla silników bez dwumasowego koła zamachowego
	Dla pojazdów ze wspomaganiem kierownicy		Dla tureckiej wersji krajowej
	Dla pojazdów bez wspomagania kierownicy		Nie dla tureckiej wersji krajowej
	Dla pojazdów z Servotronic/ z elektr. wsp. kierownicy		Piasta koła / średnica piasty koła
	Dla pojazdów bez Servotronic/ bez elektr. wsp. kierownicy		Nacisk na oś
	Dla pojazdów z klimatyzacją dachową		Dla średnicy tarczy hamulcowej [mm]
	Dla pojazdów z amortyzatorem napinania paska		Łącznik stabilizatora
	Dla pojazdów bez amortyzatora napinania paska		Rodzaj przegubu: trójramienny
START/STOP	Dla pojazdów z funkcją start-stop		Rodzaj przegubu: homokinetyczny kulowy
	Dla pojazdów bez funkcji start-stop		Strona montażu: przy wahaczu
	Dla pojazdów ze stabilizatorem		Strona montażu: przy drążku skrętnym
SPORT	Dla pojazdów z podwoziem sportowym		Dla pojazdów ze wzmocnionym stabilizatorem

Informacje dot. wykorzystania artykułów

	Specjalna konstrukcja		Uszczelnienie
	Dla pojazdów z alternatorem z rozrusznikiem		Uszczelniacz wału korbowego
	Dla pojazdów bez alternatora z rozrusznikiem		Koło zębate
	Dla producentów kół zamachowych LuK		Zestaw kompletny
	Dla producentów kół zamachowych Sachs		Części patrz zestawienie materiałowe
	Dla producentów kół zamachowych Valeo		

Skróty

SAC	Sprzęgło samonastawne	ORGA	Numer organu
DC	Prąd stały	VERSION	Wersja
BS	Wałek wyrównowazający	VET	Numer VET
HYDP	Pompa hydrauliczna	ACC	Klimatyzacja automatyczna
AirComp	Sprężarka powietrza	HA	Właściciel
VP	Pompa próżniowa	V	Napięcie (Volt)
OILP	Pompa oleju	incl.	Łącznie z
MY	Rocznik modelu	excl.	Bez
INJP	Pompa wtryskowa	+	z
HD	Wzmocnione	—	bez



Portal warsztatowy dla fachowców.

W ramach portalu REPERT oferujemy szeroki zakres usług wsparcia technicznego naszych produktów i rozwiązań, związanych z markami LuK, INA, FAG i Ruville. Szukasz konkretnych informacji w zakresie diagnostyki uszkodzenia? Potrzebujesz określonych, praktycznych wskazówek, ułatwiających codzienną działalność warsztatu? Zarówno na portalu online, czy poprzez telefoniczne konsultacje ze specjalistami, lub w trakcie wydarzeń typu np. targi motoryzacyjne – REPERT oferuje pomoc w rozwiązaniu problemów technicznych.

PRAKTYKA

- Przegląd produktów Schaeffler
- Katalog doboru części online - TecDoc
- Instrukcje montażowe
- Zalety produktów
- Ulepszony sklep bonusowy
- Diagnostyka uszkodzeń

WIEDZA

- Wiedza o produktach
- Oferta i tematy szkoleń
- Filmy szkoleniowe

INFORMACJE

- Kalendarz imprez
- Nowości dot. produktów, technologii i wiele więcej

Zarejestruj się teraz – kilkoma kliknięciami - bezpłatnie:
www.rexpert.pl

Codziennie aktualizowane informacje dot. produktów marek LuK, INA, FAG i Ruville: +48 22 245 85 55*

*bezpłatny numer telefonu, pon. – czw. 8.00 – 17.30, piąt. 8.00 – 17.00

TecDoc



Aktualizacja katalogu/późniejsze wpisy? W przyszłości to nie problem!

Skorzystaj z możliwości, które daje Ci płyta DVD TecDoc. Dzięki temu masz gwarancję, że co kwartał będą Ci udostępniane aktualne dane katalogowe niezbędne w Twojej codziennej pracy.

Zamówienia proszę kierować do:

TecAlliance GmbH
Arnikaweg 3
D-51109 Köln
Tel. +49 (0) 221/66 00-112
Fax +49 (0) 221/66 00-100
e-mail: tecdoc@tecalliance.net

Obsługa gwarancyjna online przez TecWarranty





Portal warsztatowy dla fachowców.

W ramach portalu REXPERT oferujemy szeroki zakres usług wsparcia technicznego naszych produktów i rozwiązań, związanych z markami LuK, INA, FAG i Ruville. Szukasz konkretnych informacji w zakresie diagnostyki uszkodzenia? Potrzebujesz określonych, praktycznych wskazówek, ułatwiających codzienną działalność warsztatu? Zarówno na portalu online, czy poprzez telefoniczne konsultacje ze specjalistami, lub w trakcie wydarzeń typu np. targi motoryzacyjne – REXPERT oferuje pomoc w rozwiązaniu problemów technicznych.

PRAKTYKA

- Przegląd produktów Schaeffler
- Katalog doboru części online - TecDoc
- Instrukcje montażowe
- Zalety produktów
- Ulepszony sklep bonusowy
- Diagnostyka uszkodzeń

WIEDZA

- Wiedza o produktach
- Oferta i tematy szkoleń
- Filmy szkoleniowe

INFORMACJE

- Kalendarz imprez
- Nowości dot. produktów, technologii i wiele więcej

Zarejestruj się teraz – kilkoma kliknięciami - bezpłatnie:
www.rexpert.pl

Codziennie aktualizowane informacje dot. produktów marek LuK, INA, FAG i Ruville: +48 22 245 85 55*

*bezpłatny numer telefonu, pon. – czw. 8.00 – 17.30, piąt. 8.00 – 17.00

TecDoc



Aktualizacja katalogu/późniejsze wpisy? W przyszłości to nie problem!

Skorzystaj z możliwości, które daje Ci płyta DVD TecDoc. Dzięki temu masz gwarancję, że co kwartał będą Ci udostępniane aktualne dane katalogowe niezbędne w Twojej codziennej pracy.

Zamówienia proszę kierować do:

TecAlliance GmbH
Arnikaweg 3
D-51109 Köln
Tel. +49 (0) 221/66 00-112
Fax +49 (0) 221/66 00-100
e-mail: tecdoc@tecalliance.net

Obsługa gwarancyjna online przez TecWarranty





Portal warsztatowy dla fachowców.

W ramach portalu REPERT oferujemy szeroki zakres usług wsparcia technicznego naszych produktów i rozwiązań, związanych z markami LuK, INA, FAG i Ruville. Szukasz konkretnych informacji w zakresie diagnostyki uszkodzenia? Potrzebujesz określonych, praktycznych wskazówek, ułatwiających codzienną działalność warsztatu? Zarówno na portalu online, czy poprzez telefoniczne konsultacje ze specjalistami, lub w trakcie wydarzeń typu np. targi motoryzacyjne – REPERT oferuje pomoc w rozwiązaniu problemów technicznych.

PRAKTYKA

- Przegląd produktów Schaeffler
- Katalog doboru części online - TecDoc
- Instrukcje montażowe
- Zalety produktów
- Ulepszony sklep bonusowy
- Diagnostyka uszkodzeń

WIEDZA

- Wiedza o produktach
- Oferta i tematy szkoleń
- Filmy szkoleniowe

INFORMACJE

- Kalendarz imprez
- Nowości dot. produktów, technologii i wiele więcej

Zarejestruj się teraz – kilkoma kliknięciami - bezpłatnie:

www.rexpert.pl

Codziennie aktualizowane informacje dot. produktów marek LuK, INA, FAG i Ruville: +48 22 245 85 55*

*bezpłatny numer telefonu, pon. – czw. 8.00 – 17.30, piąt. 8.00 – 17.00

TecDoc



Aktualizacja katalogu/późniejsze wpisy? W przyszłości to nie problem!

Skorzystaj z możliwości, które daje Ci płyta DVD TecDoc. Dzięki temu masz gwarancję, że co kwartał będą Ci udostępniane aktualne dane katalogowe niezbędne w Twojej codziennej pracy.

Zamówienia proszę kierować do:

TecAlliance GmbH
Arnikaweg 3
D-51109 Köln
Tel. +49 (0) 221/66 00-112
Fax +49 (0) 221/66 00-100
e-mail: tecdoc@tecalliance.net

Obsługa gwarancyjna online przez TecWarranty





Легкий коммерческий транспорт: растущий рынок	100
Краткий обзор продукции компании Schaeffler на вторичном рынке автозапчастей	102
Товарные группы	108
Компоновка страниц	109
Информация по применению артикула	110

CITROËN	114
BERLINGO	114
JUMPER	127
FIAT	139
DOBLO	139
DUCATO	151
FIORINO	176
SCUDO	178
TALENTO	182
FORD	183
TRANSIT	183
FUSO (MITSUBISHI)	216
CANTER	216
GAZ	216
GAZELLE	216
HYUNDAI	217
H-1	217
H200	221
IVECO	222
DAILY	222

MAN	289
TGE	289
MERCEDES-BENZ	290
SPRINTER	290
VITO	357
MITSUBISHI	375
CANTER	375
L200	376
L300	376
NISSAN	376
CABSTAR	376
INTERSTAR	377
NT400	386
NV200	386
NV300	388
NV400	390
PRIMASTAR	401
OPEL	410
COMBO	410
MOVANO	418

VIVARO	444
PEUGEOT	463
BOXER	463
EXPERT	474
PARTNER	481
RENAULT	495
KANGOO	495
MASTER	508
TRAFIC	543
TOYOTA	563
HIACE	563
VAUXHALL	569
COMBO	569
MOVANO	576
VIVARO	597
VW	615
CADDY	615
CRAFTER	635
LT	641
TRANSPORTER	642

 Inhalt ... 3

 Content ... 19

 Contenu ... 35

 Índice ... 51

 Indice ... 67

 Spis treści ... 83

Перечень артикулов	678
--------------------	-----

Любое копирование, тиражирование, а также полное или частичное использование информации из этого каталога запрещены без предварительного письменного согласия правообладателя. Schaeffler Automotive Aftermarket GmbH

& Co. KG не несет ответственности за возможные ошибки и оставляет за собой право на внесение изменений в спецификации и характеристики продукции.

Легкий коммерческий транспорт: растущий рынок

Прогрессивная и перспективная отрасль

Уже сейчас нельзя представить нашу повседневную жизнь без легкого коммерческого транспорта. Грузовые автомобили малой грузоподъемности во всех вариантах исполнения пользуются большой популярностью как никогда раньше. При прогнозируемом ежегодном темпе роста рынка в 8 % они представляют собой наиболее быстрорастущий сегмент автомобильного рынка и основу коммерческих перевозок. Наблюдается тенденция роста, поскольку значительно возросла популярность онлайн-торговли и как никогда востребована быстрая доставка товаров на дом.

На участке от последнего распределительного центра до потребителя, также называемом «последняя миля», наблюдается стремительный рост в сфере курьерской экспресс-доставки грузов и посылок. Согласно прогнозам размер грузов и посылок уменьшится, их количество увеличится более чем в два раза, а экспресс-доставки в день отправления станут реальностью. В результате растет спрос на грузовые автомобили малой грузоподъемности для коммерческого использования, которые могут быстро и удобно доставлять Ваш товар. Это является важным критерием в особенности для городов, поскольку уже в 2025 году четверть населения Земли будет проживать в 600 крупнейших городах, на которые будет приходиться более половины мирового объема производства

Раскрытие потенциала

Быстроразвивающаяся отрасль по производству легкого коммерческого транспорта имеет огромный потенциал для независимых СТО и создает новые бизнес-модели. Это связано с тем, что в городских условиях транспортные средства должны отличаться высокой маневренностью и скоростью движения; они должны выдерживать большие расстояния, перевозить тяжелые грузы и безупречно работать даже в экстремальных условиях. Их эксплуатируют транспортные компании, курьерские службы и предприятия розничной торговли. Эти автомобили могут делать до 120 остановок за день. Также пробег свыше 100 000 километров в год для таких машин не явля-

ется редкостью – и это при условиях постоянной нехватки времени. Поэтому имеют место высокий уровень износа и расходы по ремонту.

Независимые СТО могут занять свою нишу на этом постоянно растущем рынке, для этого им необходимо расширить клиентскую базу, включив в нее коммерческие организации, обеспечивающие логистику, и предоставлять новые услуги, связанные с обслуживанием грузовых автомобилей малой грузоподъемности. Для быстрого и простого ремонта легкого коммерческого транспорта подразделение Schaeffler Automotive Aftermarket предлагает ремонтные решения для трансмиссии, двигателя и ходовой части, которые отличаются быстротой и простотой монтажа и позволяют сократить время простоя.

Предоставление дополнительных услуг и продажа запасных частей обеспечивают большую загрузку СТО и дают возможность зарекомендовать себя как специалиста в области обслуживания легкого коммерческого транспорта. Существует большое разнообразие моделей легковых автомобилей, в то время как большая часть рынка грузовых автомобилей малой грузоподъемности ограничивается следующими ходовыми моделями: Ford Transit, Mercedes Benz Sprinter, Fiat Ducato и VW Transporter. При этом Ford Transit является наиболее популярной моделью легкого коммерческого транспорта. Каждый десятый автомобиль в Европе Ford Transit, затем следуют Mercedes Benz Sprinter и VW Transporter.

В частности для грузовых СТО открываются новые возможности ведения бизнеса: коммерческие организации, обеспечивающие логистику, ценят быстрый и надежный ремонт, чтобы как можно быстрее вернуть транспортное средство в эксплуатацию. Простой транспорта приводит к большим убыткам, и может стоить до 1000 Евро в день. Поэтому эксплуатационные расходы являются ведущим конкурентным преимуществом в отрасли, которая характеризуется дефицитом времени и требованием по сокращению расходов.



Транспортная отрасль быстро развивается. Стремительный рост онлайн-продаж стимулировал развитие курьерской службы экспресс-доставки грузов и посылок, а также спрос на легкий коммерческий транспорт.



Большая доля грузовых автомобилей малой грузоподъемности на рынке, а также высокие темпы роста данного сегмента рынка заставляют любую СТО для грузовых автомобилей задуматься о включении обслуживания данного типа транспорта в перечень оказываемых услуг и его активном продвижении.

Ассортимент для коммерческих автомобилей различных марок

Двадцать четыре часа, семь дней в неделю: от коммерческих автомобилей, таких как цельнометаллические и тентованные фургоны, шасси и автобусы, ежедневно требуется возможность эксплуатации в самых экстремальных условиях. При этом они подвержены более сильному износу и должны чаще ремонтироваться, чем легковые автомобили.

Именно для этого типа транспорта компания Schaeffler предлагает простые и эффективные ремонтные решения. Помимо расходов на ремонт, в сфере B2B решающее значение имеет время простоя при проведении ремонтных работ. Чем проще ремонтное решение в установке, тем быстрее автомобиль может продолжить свой путь. Кроме того, высококачественные компоненты с большим сроком службы позволяют увеличить межсервисный интервал. Эти особые требования компания Schaeffler учла при разработке ассортимента продукции брендов LuK, INA, FAG и Ruville для независимого рынка автозапчастей; в будущем компания планирует еще больше концентрироваться на нуждах транспортных компаний и операторов автопарков. Ассортимент включает в себя высококачественные компоненты и решения по ремонту трансмиссии, двигателя и ходовой части – все от одного производителя.

Вся продукция для легкого коммерческого транспорта разработана с целью повышения мобильности и снижения эксплуатационных расходов. В центре внимания находятся ремонтные решения, которые отличаются длительным сроком службы и обеспечивают оптимизацию затрат, а также ассортимент продукции для основных автомобилей данной отрасли, таких как Ford Transit и Mercedes-Benz Sprinter. Из этого в равной степени извлекают выгоду как менеджеры автопарка, водители автомобилей, СТО, так и компании по продаже запчастей.

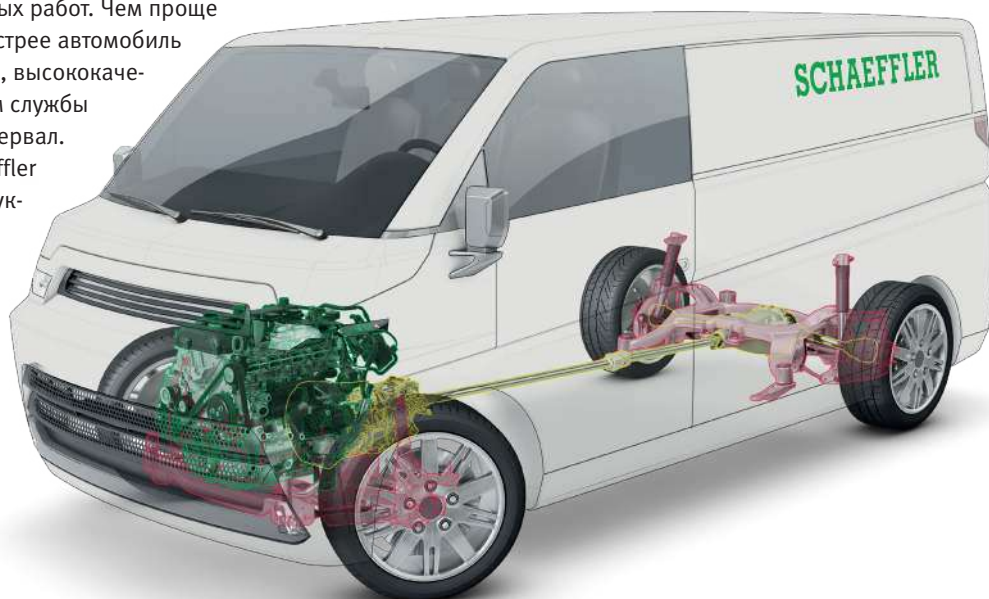

Все от одного производителя – решения по ремонту трансмиссии, двигателя и ходовой части.

Краткий обзор продукции компании Schaeffler на вторичном рынке автозапчастей

Impact Torque Limiter (ограничитель пикового крутящего момента)

Длительный срок службы благодаря защите от перегрузок

Легкий коммерческий транспорт подвергается чрезмерным нагрузкам: загрузка товаров на максимально допустимую полную массу, длинный и тем самым чувствительный приводной механизм в заднеприводных автомобилях, а также манера вождения, которая обусловлена катастрофической нехваткой времени и требованием по сокращению расходов в транспортной отрасли. Частые смена водителей и остановки не являются редкостью для легкого коммерческого транспорта и, таким образом, увеличивают нагрузку.

Для защиты приводного механизма от перегрузок и тем самым от преждевременного выхода автомобиля из строя компания Schaeffler разработала механизм ограничения пиковых моментов в приводном механизме: так называемый Impact Torque Limiter – специальное оснащение двухмассового маховика (DMF).

При попытке быстрого приведения частоты вращения двигателя к частоте вращения входного вала коробки передач возникают кратковременные пиковые нагрузки с мгновенными значениями крутящего момента, которые в несколько раз превышают максимальный крутящий момент двигателя.

Такие нагрузки могут со временем повредить DMF и негативно влияют на работу двигателя и приводного механизма. На легком коммерческом транспорте максимальные значения крутящего момента при полной загрузке еще выше.

Impact Torque Limiter обеспечивает кратковременное проскальзывание фланца, благодаря чему снижаются мгновенные пиковые нагрузки в приводном механизме.

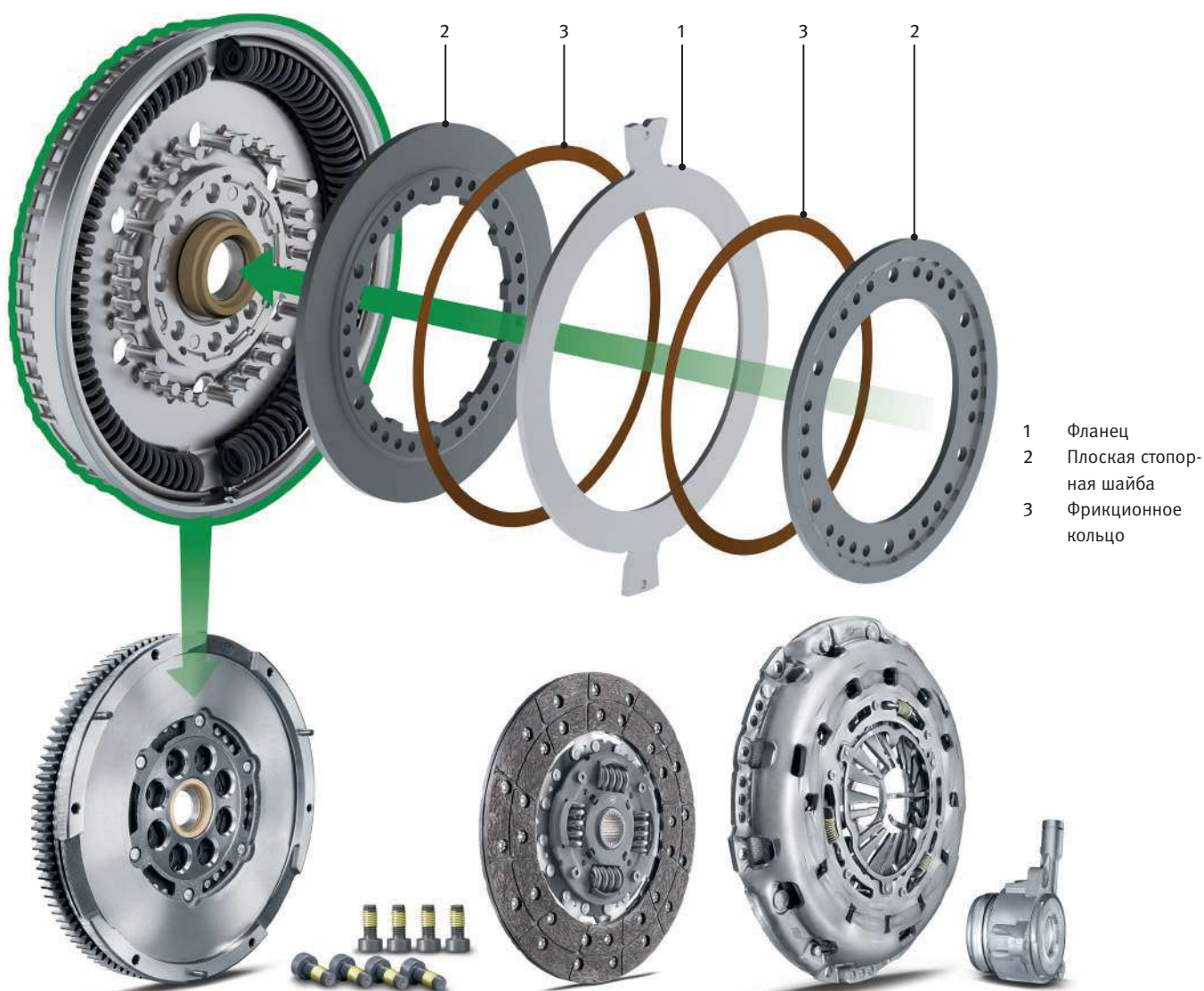

- 1 Фланец
- 2 Плоская стопорная шайба
- 3 Фрикционное кольцо

Компания Schaeffler предлагает устойчивый к ударным нагрузкам двухмассовый маховик, разработанный специально для легкого коммерческого транспорта, например для Ford Transit и IVECO Daily, и является единственным поставщиком этого решения на рынке.



В центре внимания операторы автопарков: здесь все, что Вам нужно – LuK GearBOX

Любая коробка переключения передач, независимо от изготовителя, с течением времени подвержена износу. На легком коммерческом транспорте, где ежегодный пробег свыше 100 000 километров не является редкостью, признаки износа появляются раньше. Высокие нагрузки и частая смена манеры вождения также влияют на работу коробки переключения передач. Как правило, сначала возникает повреждение подшипника, о чем свидетельствует наличие гудящего или скрежущего шума в КПП. Если не принять соответствующие меры, это может привести к выходу из строя автомобиля и большим расходам.

Наше решение, позволяющее оптимизировать затраты: LuK GearBOX.

В основе концепции LuK GearBOX лежит глубокий анализ основных причин выхода из строя ручных КПП. Ремонтное решение включает все компоненты, которые необходимы для устранения основных причин поломок.

Также комплект LuK GearBOX содержит опорные подшипники, уплотнительные элементы и другие быстроизнашивающиеся детали, которые подлежат замене в рамках проведения профессионального ремонта, поскольку в процессе эксплуатации они подвергаются высоким нагрузкам. Для удобства ремонта компания Шэффлер также предлагает комплект специального инструмента.



Комплект LuK GearBOX содержит все компоненты, которые необходимы для устранения основных причин поломок, опорные подшипники, уплотнительные элементы и быстроизнашивающиеся детали.

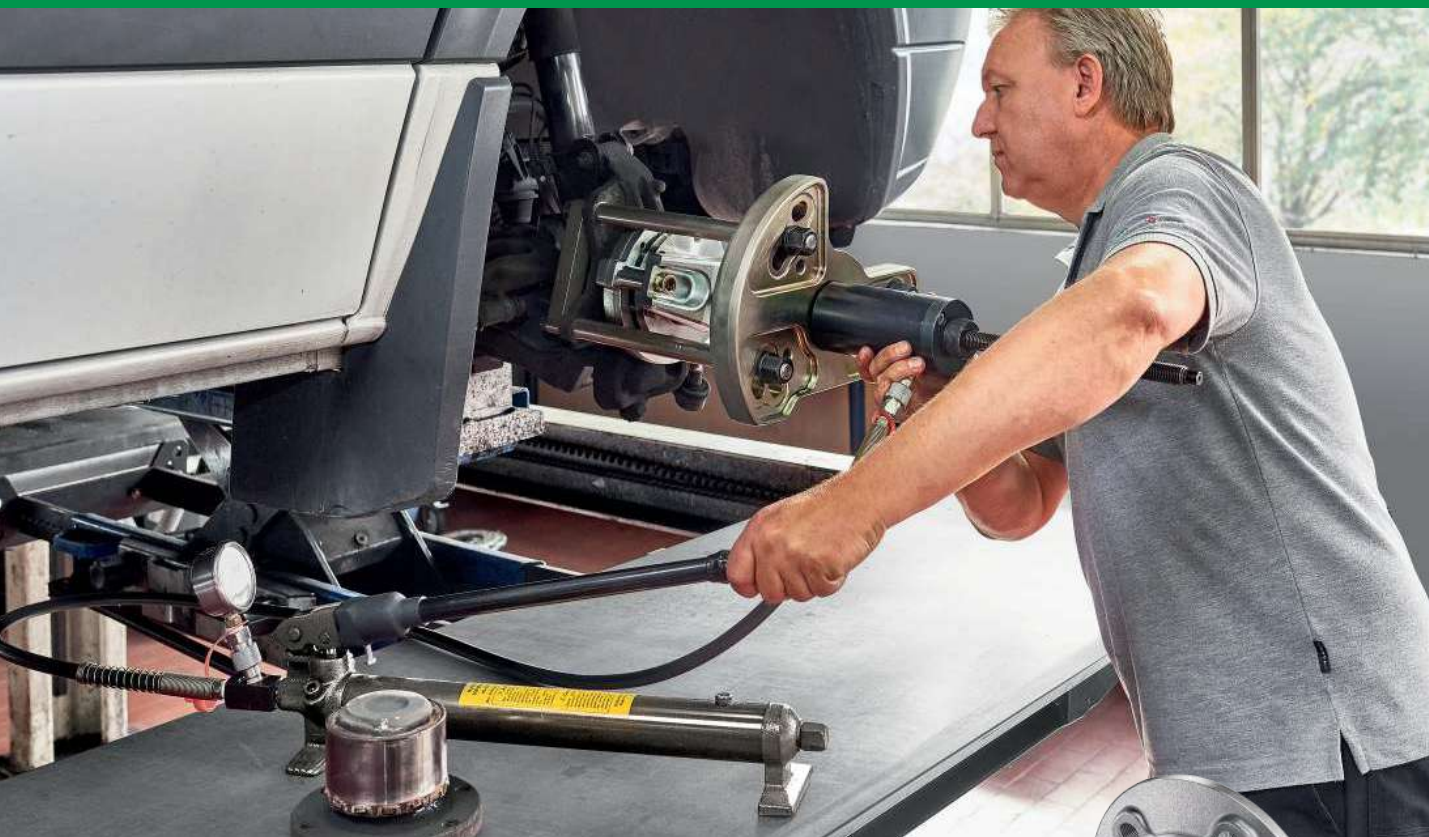

Решение FAG для ремонта ступичных подшипников на легком коммерческом транспорте

Быстрый ремонт ступичного подшипника

Решение FAG для ремонта ступичных подшипников незаменимо при обслуживании автомобилей Mercedes-Benz Sprinter, Viano, Vito и Volkswagen Crafter. Чтобы не производить полную замену поворотного кулака, компания Schaeffler разработала специальный инструмент, благодаря которому не нужно снимать поворотный кулак при ремонте ступичного подшипника. Заменяется только ступичный подшипник, поэтому после монтажа не требуется проведение работ по проверке и регулировке углов установки колес.

Этот уникальный метод ремонта позволяет СТО сократить количество рабочих операций и уменьшить время работы на 60 % по сравнению с традиционным ремонтом ступичного подшипника.

Новый метод ремонта открывает для независимых СТО новые возможности ведения бизнеса. Операторы автопарков и транспортные компании выигрывают, сокращая время простоя и увеличивая время эксплуатации коммерческих автомобилей, что способствует укреплению связей с клиентами. Клиентская база расширяется за счет коммерческих организаций, благодаря чему СТО могут предоставлять дополнительные услуги и запчасти.

Комплекты ступичных подшипников FAG

- 713 6680 10 Mercedes Benz Sprinter/VW Crafter при осевой нагрузке до 1850 кг
- 713 6680 20 Mercedes Benz Sprinter/VW Crafter при осевой нагрузке свыше 1850 кг
- 713 6680 50 Mercedes Benz Vito и Viano



Специальный инструмент FAG

- 400 6199 10

Для правильного монтажа и демонтажа комплектов ступичных подшипников FAG необходимо обязательно использовать специальный инструмент FAG.



Детали ходовой части и рулевого управления

Бескомпромиссное качество для экстремальных условий эксплуатации

Чтобы противостоять ежедневным нагрузкам, возникающим в ходе перевозок, детали ходовой части и рулевого управления производства компании Schaeffler разработаны с использованием интеллектуальных технологий и отличаются абсолютной надежностью.

Каждое изделие подвергается тщательной проверке, прежде чем попасть на рынок. В собственной лаборатории Schaeffler для всех компонентов проводится проверка размеров, функциональных возможностей и качества материала. Дополнительно независимыми институтами, такими как Рейнско-Вестфальский технический университет Ахена (RWTH), TÜV и Det Norske Veritas Germanische Lloyd (DNV GL), выполняется проверка качества.

Что касается качества и износостойкости, то здесь решающую роль играют правильный выбор материалов и их сочетание. Компания Schaeffler строго следит за обеспечением высокого уровня качества. Поэтому два года гарантии без ограничения пробега на каждый компонент является для компании Schaeffler само собой разумеющимся.

Примером гарантии качества являются пылезащитные манжеты Ruville. Благодаря использованию термопластичного полиуретана (например, Elastollan®) вместо обычного неопрена (CR), в этом компоненте обеспечивается уплотнение шарнира в течение длительного времени – он лучше противостоит таким внешним воздействиям, как вода, песок, пыль, ультрафиолетовые лучи и даже химикаты.

Кроме того, благодаря глубокой технологической обработке риск возникновения ошибок при монтаже сводится к минимуму, а материал остается максимально гибким даже при высоких температурах.



Во избежание появления ржавчины на поверхностях и истончения материала основы на компоненты также наносится гальваническое покрытие, что не является характерным для других поставщиков на рынке. Это позволяет гарантировать безупречную работу всех важных с точки зрения безопасности компонентов в любое время.



Гальванизированные поверхности и использование ультрасовременного материала Elastollan® для манжет позволяют увеличить срок их службы.

Товарные группы

	Цапфа оси, балка моста	GearBOX	Ремкомплект LuK Gear Box для МКПП
	Осевой шарнир, поперечная рулевая тяга		Ремкомплект, натяжитель поликлинового ремня
	Комплект торсионов		Ременный шкив, генератор
	Торсион		Ременный шкив, коленчатый вал
	Комплект гофрированных чехлов, первичный вал		Комплект ременных шкивов, коленчатый вал
	Опорный подшипник стойки амортизатора		Натяжитель ремня, зубчатый ремень
	Комплект гибких соединительных муфт		Рокер, механизм газораспределения
	Комплект главного и рабочего цилиндров, сцепление		Комплект винтов, маховик
	Главный цилиндр, сцепление		Гаситель колебаний, поликлиновый ремень
	Комплект шарниров, приводной вал		Гаситель колебаний, зубчатый ремень
	Шкив генератора с обгонной муфтой		Маховик
	Датчик импульсов, коленчатый вал		Натяжитель, поликлиновый ремень
	Клиновой ремень		Натяжитель, зубчатый ремень
	Поликлиновый ремень		Натяжной ролик, клиновой ремень
	Комплект поликлиновых ремней		Натяжной ролик, поликлиновый ремень
	Цепь, привод масляного насоса		Натяжной ролик, зубчатый ремень
	Комплект цепи для масляного насоса		Поперечная рулевая тяга
	Комплект сцепления LuK RepSet		Наконечник поперечной рулевой тяги
	Комплект сцепления с гидравлическим выжимным подшипником		Стабилизатор, ходовая часть
	Цапфа рычага натяжного ролика		Стойка стабилизатора
	Поперечная тяга подвески		Комплект цепи привода распределительного вала
	Монтажный комплект, шаровая опора/шарнир поворотного рычага		Регулирующий клапан, механизм изменения фаз газораспределения
	Комплект монтажного инструмента, цапфа оси (балка моста)		Толкатель, насос высокого давления
	Рабочий цилиндр, сцепление		Шаровая опора/шарнир поворотного рычага
	Распределительный вал		Натяжной/опорный ролик
	Комплект распределительного вала		Компенсатор клапанного зазора двигателя
	Регулятор фаз газораспределения		Водяной насос
	Ступичный подшипник		Водяной насос + комплект поликлиновых ремней
	Комплект ступичных подшипников		Водяной насос + комплект шестерен
	WheelPro – комплект ступичных подшипников для одной оси		Комплект инструментов, фазы газораспределения
	Ремкомплект, балка моста		Подшипник качения, опорный подшипник стойки амортизатора
	Ремкомплект, цапфа оси (балка моста)		Комплект ремня привода газораспределительного механизма
	Ремкомплект, опорный подшипник стойки амортизатора		Центральный клапан, механизм изменения фаз газораспределения

Компоновка страниц

- a Модель
- b Год изготовления
- c Информация по использованию артикула
- d Артикульный номер/группа
- e Количество страниц для нумерационного указателя/ списка деталей
- f Код двигателя
- g Информация о транспортном средстве по артикулу

a	b	c	d	e
			SCHAEFFLER	
FORD				
TRANSIT / TOURNEO CUSTOM				
2.2 TDCi CVFF; CYF4; CYFF; DRF4; DRFF; DRFG; (74-114kW) f	04.12-	SAC excl.	626 3093 33 415 0562 10 411 0120 10 532 0470 10 532 0477 10 534 0308 10 535 0160 10 FB 4EPK922 FB 6EPK873 538 0465 10 OILP 553 0223 10	
			A/C A/C # F-554766.XX g A/C 1x	
			Set 250, 260, 270, 280 290, 300, 310 330, 350, 390, 410 470 Set 713 6791 20 Set 713 6791 50 Set 713 6791 60	
			↔ ↔; I STANDARD ↔ 915272 915274 915297	

Пример

Вы ищете подходящую запасную часть для своего автомобиля. Например, Ford Transit 2012 года выпуска, передняя ось

- 1 Найдите автомобиль в каталоге
- 2 Обратите внимание на тип оси или другие критерии
- 3 Найдите артикульный номер

a	b	c	d	e
			SCHAEFFLER	
FORD				
TRANSIT / TOURNEO CUSTOM				
2.2 TDCi CVFF; CYF4; CYFF; DRF4; DRFF; DRFG; (74-114kW) 1	04.12-	SAC excl.	626 3093 33 415 0562 10 411 0120 10 532 0470 10 532 0477 10 534 0308 10 535 0160 10 FB 4EPK922 FB 6EPK873 538 0465 10 OILP 553 0223 10	
			A/C A/C # F-554766.XX A/C 1x	
			Set 250, 260, 270, 280 290, 300, 310 2 330, 350, 390, 410 470 Set 713 6791 20 3 Set 713 6791 50 Set 713 6791 60	
			↔ ↔; I STANDARD ↔ 915272 915274 915297	

Информация по применению артикула

... X	Нужное количество	BM	Не для типа оси
	Сторона установки – снаружи		Соответствует номеру производителя
	Сторона установки – внутри		Для производителя
	Сторона установки – с обеих сторон		Номер генератора
	Сторона установки – задняя ось		Исполнение оси
	Сторона установки – передняя ось		Код/модель двигателя
	Сторона установки – со стороны КПП		Полезная нагрузка (кг)
	Сторона установки – передняя ось, слева		Повышенная полезная нагрузка
	Сторона установки – передняя ось, справа		Не для повышенной полезной нагрузки
	Сторона установки – задняя ось, слева		Автомобиль специального назначения
	Сторона установки – задняя ось, справа		Не для автомобилей специального назначения
	Сторона установки – слева		Для артикульного номера/номера ОЕ
	Сторона установки – справа		Не для артикульного номера/номера ОЕ
	Сторона установки – вверх		Для номера шасси
	Сторона установки – вниз		Для разрезной оси
	Сторона установки – со стороны колеса		Для цельной оси
	Сторона установки – перед КПП		Для управляемой оси
	Идентификационный номер КПП		Для независимой подвески колес
	Приводимые в действие агрегаты: генератор		Для модели
	Приводимые в действие агрегаты: натяжной ролик		Не для модели
TURBOC	Приводимые в действие агрегаты: турбокомпрессор	EURO 4	Для стандарта Евро-4
	Приводимые в действие агрегаты: водяной насос	EURO 5	Для стандарта Евро-5
	Приводимые в действие агрегаты: вентилятор	EURO 5	Не для стандарта Евро-5
A/C	Приводимые в действие агрегаты: компрессор кондиционера	EURO 6	Для стандарта Евро-6
	Приводимые в действие агрегаты: насос гидроусилителя руля	EURO 6	Не для стандарта Евро-6
	Приводимые в действие агрегаты: прокладочная шайба		Число зубьев кольца АБС
	Приводимые в действие агрегаты: распределительный вал		Для варианта оснащения
FWD	Передний привод		Для номера КПП
RWD	Задний привод		Не для номера КПП
4WD	Полный привод		Для типа КПП
	Размер колеса (в дюймах)		Для МКПП
	Не для размера колеса (в дюймах)		Количество дорожек ремня
BM	Тип оси		

	SEQU	Для секвентальной МКПП		SPORT	Для автомобилей без спортивной настройки шасси
	SEQU	Не для секвентальной МКПП		STANDARD	Для автомобилей со стандартной ходовой частью
	SEMI	КПП: полуавтоматическая			Для автомобилей с усиленной ходовой частью
	SEMI	КПП: не полуавтоматическая			Для автомобилей без усиленной ходовой части
G5		Для пятиступенчатой МКПП	PTO		Для автомобилей с независимым валом отбора мощности
G6		Для шестиступенчатой МКПП	PTO		Для автомобилей без независимого вала отбора мощности
+		Только в комбинации с			Для жесткого механизма отбора мощности
		Форма: круг			Привод вспомогательных агрегатов
		Форма: овал			Шкив генератора с обгонной муфтой
		Внешний диаметр (мм)			Шкив коленчатого вала
ABS		Для автомобилей с АБС			Для стандартной оси
ABS		Для автомобилей без АБС			Для двускатной оси
		Внешний шлиц Tox			Не для двускатной оси
		Тип крепления: трехточечное крепление	OPTION		По желанию
LHD		Автомобиль с левосторонним рулевым управлением			Удлиненная база
RHD		Автомобиль с правосторонним рулевым управлением			Не для удлиненной базы
A/C		Для автомобилей с кондиционером			Укороченная база
A/C		Для автомобилей без кондиционера			Не для укороченной базы
		Для автомобилей с сажевым фильтром (DPF)			Сегмент отверстий АБС
		Для автомобилей без сажевого фильтра (DPF)			Сегмент зубьев АБС
		Для автомобилей с дополнительным электрическим подогревом			Для двигателей с двухмассовым маховиком
		Для автомобилей без дополнительного электрического подогрева			Для двигателей без двухмассового маховика
		Для автомобилей с усилителем рулевого управления	TR		Исполнение: для Турции
		Для автомобилей без усилителя рулевого управления	TR		Исполнение: не для Турции
		Для автомобилей с системой Сервоотроник			Колесная ступица/диаметр колесной ступицы
		Для автомобилей без системы Сервоотроник			Осевая нагрузка
A/C		Для автомобилей с кондиционером на крыше			Для диаметра тормозного диска (мм)
		Для автомобилей с демпфером натяжителя ремня			Соединительная тяга
		Для автомобилей без демпфера натяжителя ремня			Тип шарнира: «трипод»
START/STOP		Для автомобилей с функцией «старт/стоп»			Шарнир равных угловых скоростей
START/STOP		Для автомобилей без функции «старт/стоп»			Сторона установки: к поперечному рычагу
		Для автомобилей со стабилизатором			Сторона установки: торсион
SPORT		Для автомобилей со спортивной настройкой шасси			Для автомобилей с усиленным стабилизатором

Информация по применению артикула

	Особая форма кузова		Уплотнение
	Для автомобилей со стартером-генератором		Уплотнение коленчатого вала
	Для автомобилей без стартера-генератора		Зубчатая шестерня
	Для маховиков производства LuK		Полный комплект
	Для маховиков производства Sachs		Список компонентов
	Для маховиков производства Valeo		

Сокращения

SAC	Саморегулирующееся сцепление	ORGA	Организационный номер
DC	Постоянный ток	VERSION	Версия
BS	Балансирный вал	VET	Номер VET
HYDP	Насос гидроусилителя руля	ACC	Климат-контроль
AirComp	Воздушный компрессор	HA	Держатель
VP	Вакуумный насос	V	Напряжение (Вольт)
OILP	Масляный насос	incl.	Включая
MY	Год выпуска	excl.	Исключая
INJP	Топливный насос высокого давления	+	с
HD	Усиленный	—	без



Сервисный бренд для профессионалов, работающих на СТО.

Под брендом REPERT мы предлагаем комплексные услуги, связанные с применением нашей продукции и ремонтных решений LuK, INA, FAG и Ruville. Ищите ли Вы определенную информацию для диагностики неисправностей? Или Вам требуются конкретные инструменты, которые бы упростили Вашу повседневную работу в СТО? Не важно, идет ли речь об онлайн-портале, «горячей линии» сервисной поддержки или мероприятиях, REPERT предлагает Вам все услуги по техническому обслуживанию.

Работа

- Ассортимент продукции
- Онлайн-каталог REPERT
- Инструкции по монтажу
- Преимущества продукции
- Диагностика неисправностей

Обучение

- Знание продукции
- Доступные программы обучения и их содержание
- Видеоинструкции

Информация

- Календарь событий
- Новости о продукции, услугах и многом другом

Зарегистрируйтесь бесплатно прямо сейчас на сайте:
www.repxpert.ru

TecDoc



Хотите обновить каталог/получить дополнительные сведения? Скоро это не будет проблемой!

Воспользуйтесь возможностями, которые предлагает Вам TecDoc-DVD. Раз в квартал Вы будете получать актуальные данные по каталогу, необходимые для Вашей повседневной работы.

Контактные данные для заказа:

TecAlliance GmbH
Amikaweg 3
D-51109 KØln
Тел +49 (0) 221/66 00-112
Факс +49 (0) 221/66 00-100
Адрес эл. почты:
tecdoc@tecalliance.net

Онлайн-обработка гарантийных случаев осуществляется на основе TecWarranty





Сервисный бренд для профессионалов, работающих на СТО.

Под брендом REPERT мы предлагаем комплексные услуги, связанные с применением нашей продукции и ремонтных решений LuK, INA, FAG и Ruville. Ищите ли Вы определенную информацию для диагностики неисправностей? Или Вам требуются конкретные инструменты, которые бы упростили Вашу повседневную работу в СТО? Не важно, идет ли речь об онлайн-портале, «горячей линии» сервисной поддержки или мероприятиях, REPERT предлагает Вам все услуги по техническому обслуживанию.

Работа

- Ассортимент продукции
- Онлайн-каталог REPERT
- Инструкции по монтажу
- Преимущества продукции
- Диагностика неисправностей

Обучение

- Знание продукции
- Доступные программы обучения и их содержание
- Видеоинструкции

Информация

- Календарь событий
- Новости о продукции, услугах и многом другом

Зарегистрируйтесь бесплатно прямо сейчас на сайте:
www.repxpert.ru

TecDoc



Хотите обновить каталог/получить дополнительные сведения? Скоро это не будет проблемой!

Воспользуйтесь возможностями, которые предлагает Вам TecDoc-DVD. Раз в квартал Вы будете получать актуальные данные по каталогу, необходимые для Вашей повседневной работы.

Контактные данные для заказа:

TecAlliance GmbH
Amikaweg 3
D-51109 KØln
Тел +49 (0) 221/66 00-112
Факс +49 (0) 221/66 00-100
Адрес эл. почты:
tecdoc@tecalliance.net

Онлайн-обработка гарантийных случаев осуществляется на основе TecWarranty





Сервисный бренд для профессионалов, работающих на СТО.

Под брендом REPERT мы предлагаем комплексные услуги, связанные с применением нашей продукции и ремонтных решений LuK, INA, FAG и Ruville. Ищите ли Вы определенную информацию для диагностики неисправностей? Или Вам требуются конкретные инструменты, которые бы упростили Вашу повседневную работу в СТО? Не важно, идет ли речь об онлайн-портале, «горячей линии» сервисной поддержки или мероприятиях, REPERT предлагает Вам все услуги по техническому обслуживанию.

Работа

- Ассортимент продукции
- Онлайн-каталог REPERT
- Инструкции по монтажу
- Преимущества продукции
- Диагностика неисправностей

Обучение

- Знание продукции
- Доступные программы обучения и их содержание
- Видеоинструкции

Информация

- Календарь событий
- Новости о продукции, услугах и многом другом

Зарегистрируйтесь бесплатно прямо сейчас на сайте:
www.repxpert.ru

TecDoc



Хотите обновить каталог/получить дополнительные сведения? Скоро это не будет проблемой!

Воспользуйтесь возможностями, которые предлагает Вам TecDoc-DVD. Раз в квартал Вы будете получать актуальные данные по каталогу, необходимые для Вашей повседневной работы.

Контактные данные для заказа:

TecAlliance GmbH
Amikaweg 3
D-51109 KØln
Тел +49 (0) 221/66 00-112
Факс +49 (0) 221/66 00-100
Адрес эл. почты:
tecdoc@tecalliance.net































































































Онлайн-обработка гарантийных случаев осуществляется на основе TecWarranty



			SCHAEFFLER
--	---	--	-------------------

CITROËN

BERLINGO





























































































































Electric  (28kW)	07.03-12.05	FAG	right right; ORGA →07972 right; ORGA 7973→ left left ; ORGA 7973→  82 mm  ; ABS  ; ABS  ;   ;  ↓down; ORGA 7973→  ; ISTANDARD  ; 2x  50,17 mm  ; 2x  50,2 mm  ; + 965900; OPTION  ; + 965901; OPTION  	 821 0465 10  821 0466 10  821 0470 10  821 0464 10  821 0469 10  713 6401 80  713 6305 30  713 6404 60  815 0004 30  815 0005 30  818 0278 10  825 0223 10  830 0038 30  830 0039 30  830 0042 30  830 0051 30  840 0264 10  840 0922 10  1002226
Electric  Y4F1; (35-49kW)	01.11-	FAG	right left  82 mm  62 mm    right left	 821 0429 10  821 0428 10  713 6307 60  713 6406 10  815 0071 30  818 0243 10  825 0192 10  840 0321 10  840 1018 10  840 1017 10
1.4 bivalent  KFW (TU3JP); (48kW)	11.02-12.11	LUK  FAG	G5;  MA →12.09;  MA    ; →10.05; A/C  ; 10.05→09.11; A/C  ; A/C A/C   ; A/C  ; A/C  A/C  ; OPTION A/C   ; A/C   ; A/C  ; 09.11→; A/C  ; A/C  1x; ORGA 04193→	GearBOX  462 0151 10  620 3084 00  530 0335 10  530 0335 30  531 0572 10  529 0109 10  529 0149 10  529 0216 10  531 0241 10  532 0331 10  534 0179 10  544 0145 10  FB 4PK863  FB 5PK1219  FB 5PK1255  FB 5PK725  FB 5PK860  FB 6PK1718  FB 10X710  538 0055 10  553 0128 10 821 0465 10 821 0466 10 821 0470 10 821 0464 10 821 0469 10 713 6401 80 713 6305 30 713 6404 20 713 6404 50



			SCHAEFFLER
--	--	--	-------------------

CITROËN

BERLINGO

1.4 bivalent KFW (TU3JP); (48kW)	11.02-12.11	FAG	 ; 11.04→; ABS	 Set	713 6404 60			
			 ; 	 SET	772 0292 30			
				 REP	815 0004 30			
				 REP	815 0005 30			
				 —	818 0278 10			
			 ↓down; ORGA 7973→	 —	825 0223 10			
			 ; ISTANDARD	 REP	830 0038 30			
			 ; 2x	 —	830 0039 30			
			 50,17 mm					
			 ; 2x	 —	830 0042 30			
			 50,2 mm					
			 ; + 965900; OPTION	 REP	830 0051 30			
			 ; + 965901; OPTION					
				 —	840 0264 10			
				 —	840 0922 10			
				 —	1002226			
			1.4 i bivalent (MBKFW) KFW (TU3JP); (55kW)	04.03-10.05	LUK	G5 ;  MA	GearBOX	462 0151 10
							 —	620 3084 00
	 —	530 0335 10						
	 —	530 0335 30						
	 —	531 0572 10						
 ; A/C	 —	529 0109 10						
 ; A/C	 —	529 0216 10						
A/C	 —	531 0241 10						
								
	 —	544 0145 10						
	 —	FB 4PK863						
A/C  ; OPTION	 —	FB 5PK1219						
A/C 	 —	FB 5PK1255						
 ; A/C 	 —	FB 5PK725						
 ; A/C	 —	FB 5PK860						
 ; A/C 	 —	FB 10X710						
	 —	538 0055 10						
1x ; ORGA 04193→	 —	553 0128 10						
FAG						 right	 —	821 0465 10
						 right; ORGA →07972	 —	821 0466 10
						 right; ORGA 7973→	 —	821 0470 10
						 left	 —	821 0464 10
						 left; ORGA 7973→	 —	821 0469 10
							 Set	713 6401 80
						 82 mm		
						 ; ABS	 Set	713 6305 30
						 ; ABS ;  29; →10.04	 Set	713 6404 20
						 ; →10.04; ABS ;  48	 Set	713 6404 50
						 ; 11.04→; ABS	 Set	713 6404 60
						 ; 	 SET	772 0283 30
						 ; G5	 SET	772 0292 30
						 ; ABS ; →8029; ABS	 SET	772 0285 30
						 ; ABS ; →8029	 SET	772 0286 30
						 ; →8029; ABS	 SET	772 0295 30
						 ; ABS ; →8029	 SET	772 0341 30
							 REP	815 0004 30
				 REP	815 0005 30			
				 —	818 0278 10			
			 ↓down; ORGA 7973→	 —	825 0223 10			
			 ; ISTANDARD	 REP	830 0038 30			
			 ; 2x	 —	830 0039 30			
			 50,17 mm					
			 ; 2x	 —	830 0042 30			
			 50,2 mm					
			 ; + 965900; OPTION	 REP	830 0051 30			
			 ; + 965901; OPTION					
				 —	840 0264 10			
				 —	840 0922 10			
				 —	1002226			
			1.6 HDI 75 (MB9HW) 9HW (DV6BTED4); DV6B; (55kW)	07.05-12.11	LUK	 DV6B ;  BE4R	 —	624 3218 00



			SCHAEFFLER
--	---	--	-------------------

CITROËN

BERLINGO

1.6 HDi 75 (MB9HW)
 9HW (DV6BTED4); DV6B; (55kW)

07.05-12.11



DV6B; BE4R; RHD
 incl. 



624 3218 21



530 0375 10



530 0375 30



531 0555 10



532 0321 10



529 0012 10



529 0046 10



529 0186 10



529 0404 10



532 0538 10



534 0180 10



534 0400 10



535 0059 10



535 0062 10



535 0149 10



535 0179 10



535 0194 10



544 0104 10



544 0104 20



538 0037 10



428 0032 30



559 0106 10

FAG

right



821 0468 10

left



821 0467 10



713 6401 80

82 mm



713 6305 30

ABS



713 6404 60

ABS



771 0146 30



771 0436 30

90 mm



772 0444 30



815 0004 30

G5; BE4R



815 0005 30



818 0278 10



830 0038 30

ISTANDARD



830 0039 30

2x



830 0042 30

50,17 mm



830 0051 30

2x



840 0265 10

50,2 mm



840 0922 10

+ 965900; OPTION



1002226

+ 965901; OPTION



624 3218 00



530 0375 10



530 0375 30



531 0555 10



532 0321 10



529 0046 10



529 0404 10



532 0538 10



534 0400 10



535 0059 10



535 0062 10



535 0149 10



535 0179 10



535 0194 10



544 0104 10



544 0104 20



538 0037 10



428 0032 30



559 0106 10



821 0429 10



821 0428 10

1.6 HDi 75
 9HT (DV6BTED4); 9HT (DV6BU-
 TED4); (55kW)

04.08-



DV6BUTED4; BE4R



624 3218 00



530 0375 10



530 0375 30



531 0555 10



532 0321 10



529 0046 10



529 0404 10



532 0538 10



534 0400 10



535 0059 10



535 0062 10



535 0149 10



535 0179 10



535 0194 10



544 0104 10



544 0104 20



538 0037 10



428 0032 30



559 0106 10

FAG

right



821 0429 10

left



821 0428 10



			SCHAEFFLER
--	--	--	-------------------

CITROËN

BERLINGO





























































































































1.6 HDi 75 	04.08-	FAG	82 mm	Set	713 6307 60
			62 mm	Set	713 6406 10
			; BE4R	SET	772 0444 30
				REP	815 0071 30
					818 0243 10
					825 0192 10
					840 0321 10
			right		840 1018 10
			left		840 1017 10
					623 3325 00
					623 3727 00
			DV6ETED4; BE4R		530 0578 10
			DV6FE; BE4R		530 0612 10
			DV6ETED; + ;		530 0698 10
DV6FE		530 0698 10			
DV6ETED; + ;		530 0578 30			
DV6ETED; + ;		530 0612 30			
DV6FE		530 0698 30			
DV6FE		531 0829 10			
DV6ETED; + ;		531 0850 10			
DV6ETED; + ;		531 0884 10			
		532 0624 10			
; DV6ETED; A/C		529 0261 10			
; DV6FE; A/C		529 0335 10			
; A/C START/STOP ; DVETED		532 0773 10			
; DV6ETED		534 0075 20			
; DV6FE		534 0654 10			
START ; DV6FE		534 0655 10			
DV6ETED		535 0194 10			
# F-236591.05/.07		535 0308 10			
START ; DV6FE		544 0104 10			
# 920725 1008725		544 0104 20			
DV6ETED		FB 6APK1005			
DV6ETED		FB 6PK800			
; A/C		538 0037 10			
8x		420 0086 10			
12 mm		422 0018 10			
8x		428 0183 10			
1x		821 0429 10			
right		821 0428 10			
left		713 6307 60			
82 mm	Set	713 6406 10			
62 mm	Set	772 0444 30			
; BE4R	SET	815 0071 30			
	REP	818 0243 10			
		825 0192 10			
		840 0321 10			
right		840 1018 10			
left		840 1017 10			
		530 0578 10			
		530 0612 10			
		530 0578 30			
		530 0612 30			
		531 0850 10			
		531 0884 10			
		532 0624 10			
; A/C		529 0261 10			
		534 0075 20			
START		534 0427 10			
		544 0104 10			
		544 0104 20			
START		FB 6APK1020			
; A/C		FB 6PK800			



			SCHAEFFLER
--	--	--	-------------------

CITROËN

BERLINGO























































































































1.6 HDi 75 4x4 9HN (DV6ETED); (55kW)	02.12-	 FAG	8x		420 0086 10			
			8x		422 0018 10			
			1x		428 0183 10			
			 right		821 0429 10			
			 left		821 0428 10			
					713 6307 60			
					713 6406 10			
			 62 mm		713 6406 10			
			 82 mm		713 6406 10			
			 ; G5 ;  BE4R		772 0444 30			
					815 0071 30			
					818 0243 10			
					840 0321 10			
			 right		840 1018 10			
			 left		840 1017 10			
					624 3218 00			
			 BE4R; RHD		624 3218 21			
			incl. 		624 3218 21			
			1.6 HDi 90 (MB9HX, MC9HX) 9HX (DV6ATED4); (66kW)	07.05-12.11	 FAG			530 0375 10
								530 0375 30
		531 0555 10						
		532 0321 10						
 ; →10.05; A/C		529 0012 10						
 ; 10.05→; A/C		529 0046 10						
 ; →10.05; A/C		529 0186 10						
 ; 10.05→; A/C		529 0404 10						
 ; 10.05→; A/C; 1x		532 0538 10						
 ; 10.05→; A/C; 2x		532 0538 10						
 ; →10.05		534 0180 10						
 ; 10.05→		534 0400 10						
 # F-232369.04/.05/.07 F-232369.08		535 0059 10						
 # F-236591.01/.02/.04 F-236591.06		535 0062 10						
 # F-550426.XX		535 0149 10						
 # F-232369/.02/.03 F-232369.09/.11		535 0179 10						
 # F-236591.05/.07		535 0194 10						
→10.05		544 0079 10						
10.05→		544 0104 10						
→10.05		544 0079 20						
10.05→		544 0104 20						
		538 0037 10						
ORGA 10586→		428 0032 30						
1x		559 0106 10						
 right		821 0468 10						
 left		821 0467 10						
		713 6401 80						
		713 6305 30						
 ; ABS		713 6305 30						
 ; ABS		713 6404 60						
		771 0436 30						
		771 0146 30						
 90 mm		771 0146 30						
 ; G5 ;  BE4R		772 0444 30						
		815 0004 30						
		815 0005 30						
		818 0278 10						
 ; I STANDARD		830 0038 30						
 ; 2x		830 0039 30						
 50,17 mm		830 0042 30						
 ; 2x		830 0042 30						
 50,2 mm		830 0042 30						
 ; + 965900; OPTION		830 0051 30						
 ; + 965901; OPTION		830 0051 30						
		840 0265 10						
		840 0922 10						
1.6 NFR (TU5JP4B); (66kW)	04.08-	  			1002226			
					620 3087 00			
					530 0379 10			
					530 0379 30			



			SCHAEFFLER
--	---	--	-------------------

CITROËN

BERLINGO



















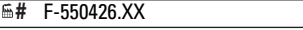
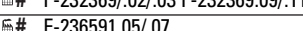

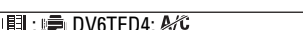
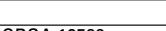





























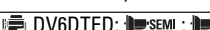



























































1.6  NFR (TU5JP4B); (66kW)	04.08-				531 0632 10
					532 0395 10
					532 0331 10
					534 0447 10
					544 0145 10
					FB 6PK1203
					FB 6PK1698
					538 0052 10
					428 0033 30
			1x		553 0272 10
		FAG	 right		821 0429 10
			 left		821 0428 10
			 82 mm		Set 713 6307 60
			 62 mm		Set 713 6406 10
			  G5;  BE4R		SET 772 0444 30
					REP 815 0071 30
					818 0243 10
					825 0192 10
					840 0321 10
			 right		840 1018 10
 left		840 1017 10			
1.6 HDi 90 16V  9HX (DV6ATED4); (66kW)	04.08-		RHD		624 3218 00
			incl. 		624 3218 21
			→11.09;  BE4R		415 0396 10
					530 0375 10
					530 0375 30
					531 0555 10
					532 0321 10
					529 0046 10
			 1x		529 0404 10
			 2x		532 0538 10
				534 0400 10	
				544 0104 10	
				544 0104 20	
				538 0037 10	
				428 0032 30	
		FAG	 right		821 0429 10
			 left		821 0428 10
			 82 mm		Set 713 6307 60
			 62 mm		Set 713 6406 10
			  G5;  BE4R		SET 772 0444 30
			REP 815 0071 30		
			818 0243 10		
			825 0192 10		
			840 0321 10		
 right			840 1018 10		
 left		840 1017 10			
1.6 HDi 90 16V  9HS (DV6TED4BU); 9HX (DV6AUTED4); (66kW)	04.08-		 DV6TED4BU; →11.09;  BE4R		600 0084 00
			incl. 		623 3241 00
			 DV6TED4BU; →11.09;  BE4R		623 3325 00
			 DV6TED4BU; 12.09→;  BE4R		624 3218 00
			 DV6ATED4 DV6AUTED4;  BE4R		624 3218 21
			 DV6ATED4 DV6AUTED4;  BE4R; RHD		624 3218 21
			incl. 		415 0396 10
			 DV6TED4BU; →11.09;  BE4R		411 0166 10
			 DV6TED4BU;  BE4R; →11.09		530 0375 10
					530 0375 30
		531 0555 10			
		532 0321 10			
 DV6ATED4; A/C		529 0046 10			
DV6TED4; A/C		529 0261 10			
DV6ATED4; A/C		529 0404 10			



			SCHAEFFLER
--	---	--	-------------------

CITROËN



























































BERLINGO

<p>1.6 HDi 90 16V  9HS (DV6TED4BU); 9HX (DV6AUTED4); (66kW)</p>	<p>04.08-</p>	<p></p>	<p> ;  DV6ATED4; A/C ; 1x  ;  DV6ATED4; A/C ; 2x  DV6TED4  DV6ATED4  F-232369.04/.05/.07 F-232369.08  F-236591.01/.02/.04 F-236591.06  F-550426.XX  F-232369/.02/.03 F-232369.09/.11  F-236591.05/.07  DV6TED4; A/C ORGA 10586 → 1x</p>	<p> 532 0538 10  534 0075 20  534 0400 10  535 0059 10  535 0062 10  535 0149 10  535 0179 10  535 0194 10  544 0104 10  544 0104 20  FB 6PK800  538 0037 10  428 0032 30  559 0106 10  821 0429 10  821 0428 10  713 6307 60  713 6406 10  772 0444 30  815 0071 30  818 0243 10  825 0192 10  840 0321 10  840 1018 10  840 1017 10</p>
<p>1.6 HDi 90  9HE (DV6DBM); 9HF (DV6DTED); (66kW)</p>	<p>07.10-</p>	<p></p>	<p> DV6DTED; SEMI ; MC EGS6 ; START/STOP  DV6DTED; MANU ; BE4R  DV6ATED4; BE4R  DV6DTED; SEMI ; MC EGS6 ; START/STOP  DV6DTED; SEMI ; MC EGS6 ; START/STOP   530 0578 10  530 0612 10  530 0578 30  530 0612 30  531 0850 10  531 0884 10  532 0624 10  529 0261 10  534 0075 20  534 0427 10  535 0194 10  544 0104 10  544 0104 20  FB 6APK1020  FB 6PK800  420 0086 10  422 0018 10  428 0183 10 <p>FAG</p>  right  left  82 mm  62 mm  G5 ; BE4R  815 0071 30  818 0243 10  825 0192 10  840 0321 10  840 1018 10  840 1017 10</p>	<p> 623 3241 34  623 3325 00  624 3218 00  415 0396 10  411 0166 10  530 0578 10  530 0612 10  530 0578 30  530 0612 30  531 0850 10  531 0884 10  532 0624 10  529 0261 10  534 0075 20  534 0427 10  535 0194 10  544 0104 10  544 0104 20  FB 6APK1020  FB 6PK800  420 0086 10  422 0018 10  428 0183 10 <p>FAG</p>  821 0429 10  821 0428 10  713 6307 60  713 6406 10  772 0444 30  815 0071 30  818 0243 10  825 0192 10 840 0321 10 840 1018 10 840 1017 10</p>
<p>1.6 HDi 90 4x4  9HF (DV6DTED); (66kW)</p>	<p>02.12-</p>	<p></p>	<p> 530 0578 10  530 0612 10</p>	<p> 530 0578 10  530 0612 10</p>



			SCHAEFFLER
--	---	--	-------------------

CITROËN

























































































































BERLINGO				
1.6 HDi 90 4x4 9HF (DV6DTED); (66kW)	02.12-		+ ;	 530 0578 30
			+ ;	 530 0612 30
			+ ;	 531 0850 10
			+ ;	 531 0884 10
				 532 0624 10
			; A/C	 529 0261 10
				 534 0075 20
			START	 534 0427 10
				 544 0104 10
				 544 0104 20
		START	FB 6APK1020	
		; A/C	FB 6PK800	
		8x	420 0086 10	
		12 mm		
		8x	 422 0018 10	
		1x	 428 0183 10	
		FAG	right	 821 0429 10
			left	 821 0428 10
				 713 6307 60
			82 mm	
	 713 6406 10			
62 mm				
; G5 G6 ; BE4R	 772 0444 30			
	 815 0071 30			
	 818 0243 10			
	 840 0321 10			
right	 840 1018 10			
left	 840 1017 10			
1.6 HDi 90 9HJ (DV6DTEDM); 9HP (DV6DTED); (68kW)	07.10-		DV6DTED; SEMI ; MC EGS6 ; START/STOP	 623 3241 34
			DV6DTED; MANU ; BE4R	 623 3325 00
			DV6DTED; SEMI ; MC EGS6 ; START/STOP	 415 0396 10
			DV6DTED; SEMI ; MC EGS6 ; START/STOP	 411 0166 10
			+ ;	 530 0578 10
			+ ;	 530 0612 10
			+ ;	 530 0578 30
			+ ;	 530 0612 30
			+ ;	 531 0850 10
			+ ;	 531 0884 10
	 532 0624 10			
; A/C	 529 0261 10			
; A/C START/STOP	 532 0773 10			
	 534 0075 20			
START	 534 0427 10			
START/STOP	 535 0194 10			
# F-236591.05/.07				
	 544 0104 10			
	 544 0104 20			
START	FB 6APK1020			
; A/C	FB 6PK800			
	 538 0037 10			
8x	420 0086 10			
12 mm				
8x	 422 0018 10			
1x	 428 0183 10			
FAG	right	 821 0429 10		
	left	 821 0428 10		
		 713 6307 60		
	82 mm			
		 713 6406 10		
	62 mm			
	; G5 G6 ; BE4R	 772 0444 30		
		 815 0071 30		
		 818 0243 10		
		 825 0192 10		
	 840 0321 10			
right	 840 1018 10			
left	 840 1017 10			
1.6 HDi 92 9HJ (DV6DTEDM); (68kW)	07.10-			 623 3325 00



			<p>SCHAEFFLER</p>
--	--	--	--------------------------

CITROËN

BERLINGO



















































































































<p>1.6 HDi 92  9HJ (DV6DTEDM); (68kW)</p>	<p>07.10-</p>	<p></p>	<p>+  ; </p> <p>+  ; </p> <p>+  ; </p> <p>+  ; </p> <p>+  ; </p> <p>+  ; </p> <p> ; A/C</p> <p></p> <p> START</p> <p></p> <p> START</p> <p> ; A/C</p> <p> ; A/C</p> <p>8x  12 mm</p> <p>8x </p> <p>1x </p> <p>FAG  right</p> <p> left</p> <p> 82 mm</p> <p> 62 mm</p> <p></p> <p></p> <p></p> <p> right</p> <p> left</p>	<p> 530 0578 10</p> <p> 530 0612 10</p> <p> 530 0578 30</p> <p> 530 0612 30</p> <p> 531 0850 10</p> <p> 531 0884 10</p> <p> 532 0624 10</p> <p> 529 0261 10</p> <p> 534 0075 20</p> <p> 534 0427 10</p> <p> 544 0104 10</p> <p> 544 0104 20</p> <p> FB 6APK1020</p> <p> FB 6PK800</p> <p> FB 6PK962</p> <p> 420 0086 10</p> <p> 422 0018 10</p> <p> 428 0183 10</p> <p> 821 0429 10</p> <p> 821 0428 10</p> <p> Set 713 6307 60</p> <p> Set 713 6406 10</p> <p> REP 815 0071 30</p> <p> 818 0243 10</p> <p> 840 0321 10</p> <p> 840 1018 10</p> <p> 840 1017 10</p> <p> 623 3323 00</p>
<p>1.6 VTi 95  5FK (EP6CB); (72kW)</p>	<p>07.10-</p>	<p></p> <p></p>	<p> ; A/C</p> <p> ; A/C</p> <p> ; A/C</p> <p></p> <p></p> <p></p> <p> # F-560565.XX</p> <p> # F-556533.XX</p> <p> # F-560968.XX</p> <p></p> <p> EP6C</p> <p>8x;  12 mm</p> <p>8x;  12 mm</p> <p></p> <p></p> <p></p> <p></p> <p></p> <p></p> <p>8x;  12 mm</p> <p>1x </p> <p>1x </p> <p>FAG  right</p> <p> left</p> <p> 82 mm</p> <p> 62 mm</p> <p> ; G5 ; BE4R</p> <p></p> <p></p> <p></p> <p> right</p> <p> left</p>	<p> 529 0266 10</p> <p> 529 0308 10</p> <p> 531 0866 10</p> <p> 532 0912 10</p> <p> 532 0676 10</p> <p> 534 0425 10</p> <p> 535 0166 10</p> <p> 535 0178 10</p> <p> 535 0193 10</p> <p> 544 0096 10</p> <p> 538 0466 10</p> <p> 420 0226 10</p> <p> 420 0229 10</p> <p> 422 0221 10</p> <p> 422 0222 10</p> <p> 422 0223 10</p> <p> 422 0224 10</p> <p> 422 0225 10</p> <p> 422 0226 10</p> <p> 553 0237 10</p> <p> KIT 559 0104 10</p> <p> 821 0429 10</p> <p> 821 0428 10</p> <p> Set 713 6307 60</p> <p> Set 713 6406 10</p> <p> SET 772 0444 30</p> <p> REP 815 0071 30</p> <p> 818 0243 10</p> <p> 825 0192 10</p> <p> 840 0321 10</p> <p> 840 1018 10</p> <p> 840 1017 10</p> <p> 623 3727 00</p>
<p>1.6 BlueHDi 100  BHJ (DV6FD); (73kW)</p>	<p>12.14-</p>	<p></p>	<p> BE4R</p>	<p> 623 3727 00</p>



			SCHAEFFLER
--	--	--	-------------------

CITROËN

BERLINGO

1.6 BlueHDi 100  BHY (DV6FD); (73kW)	12.14-				530 0698 10	
					530 0698 30	
					531 0829 10	
					532 0624 10	
					529 0335 10	
					534 0654 10	
					534 0655 10	
					535 0308 10	
			 # 920725 1008725			
					FB 6APK1005	
				FB 6PK800		
				538 0037 10		
				538 0037 10		
		8x		420 0086 10		
		 12 mm				
		8x		422 0018 10		
		1x		428 0183 10		
		FAG	 right		821 0429 10	
			 left		821 0428 10	
					713 6307 60	
 82 mm						
 62 mm			713 6406 10			
 G5 ;  BE4R			772 0444 30			
			815 0071 30			
			818 0243 10			
			825 0192 10			
			840 0321 10			
 right		840 1018 10				
 left		840 1017 10				
1.6 BlueHDi 100 4x4  BHY (DV6FD); (73kW)	12.14-	LUK			623 3727 00	
						530 0698 10
						530 0698 30
						531 0829 10
						532 0624 10
						529 0335 10
						534 0654 10
						534 0655 10
						535 0308 10
				 # 920725 1008725		
					FB 6APK1005	
				FB 6PK800		
		8x		420 0086 10		
		 12 mm				
		8x		422 0018 10		
		1x		428 0183 10		
		FAG	 right		821 0429 10	
			 left		821 0428 10	
					713 6307 60	
			 82 mm			
 62 mm			713 6406 10			
 G5 ;  BE4R			772 0444 30			
			815 0071 30			
			818 0243 10			
			840 0321 10			
 right			840 1018 10			
 left		840 1017 10				
1.6  NFU (TU5JP4); (80kW)	04.08-	LUK			620 3087 00	
						530 0379 10
						530 0379 30
						531 0632 10
						532 0395 10
						532 0331 10
						534 0447 10
						544 0145 10
						FB 6PK1203
						FB 6PK1698
		538 0052 10				
		428 0033 30				



			SCHAEFFLER
--	--	--	-------------------

CITROËN

BERLINGO















































































































1.6 NFU (TU5JP4); (80kW)	04.08-	 FAG	1x		553 0272 10		
					821 0429 10		
					821 0428 10		
					713 6307 60		
					713 6406 10		
					772 0444 30		
					815 0071 30		
					818 0243 10		
					825 0192 10		
					840 0321 10		
					840 1018 10		
					840 1017 10		
					600 0084 00		
					623 3241 00		
			1.6 HDi 110 9HZ (DV6TED4); (80kW)	04.08-		→11.09; BE4R	
incl. ; incl.		415 0396 10					
→11.09; BE4R		411 0166 10					
12.09 →; BE4R		530 0375 30					
→11.09; BE4R		531 0555 10					
→11.09; BE4R		532 0321 10					
; # F-232369.04/.05 F-232369.07/.08; ; A/C		529 0061 10					
; # F-232369 /02 F-232369.03/.09; ; A/C		529 0062 10					
; # F-236591.01/.02 F-236591.04/.06; ; A/C		529 0065 10					
; # F-236591.05/.07; ; A/C		529 0066 10					
; A/C		529 0261 10					
		534 0075 20					
# F-232369.04/.05/.07 F-232369.08		535 0059 10					
# F-236591.01/.02/.04 F-236591.06		535 0062 10					
# F-550426.XX		535 0149 10					
# F-232369.02/.03 F-232369.09/.11		535 0179 10					
# F-236591.05/.07		535 0194 10					
		544 0104 10					
		544 0104 20					
; A/C		FB 6PK800					
		538 0037 10					
		428 0032 30					
1.6 16V NFU (TU5JP4); (81kW)	08.05-12.07				1x		559 0106 10
							821 0429 10
							821 0428 10
							713 6307 60
							713 6406 10
					772 0444 30		
					815 0071 30		
					818 0243 10		
					825 0192 10		
					840 0321 10		
					840 1018 10		
					840 1017 10		
					530 0237 10		
					530 0379 10		
					530 0237 30		
		530 0379 30					
		531 0478 10					
		531 0632 10					
		532 0142 10					
		532 0395 10					
		529 0149 10					
		529 0216 10					
		531 0241 10					
		544 0145 10					
		FB 4PK863					



			SCHAEFFLER
--	---	--	-------------------

CITROËN

BERLINGO











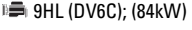































































































1.6 16V NFU (TU5JP4); (81kW)	08.05-12.07	 FAG	A/C ⇄ ; OPTION		FB 5PK1219
			A/C ⇄		FB 5PK1255
			⇄ ; A/C		FB 5PK860
			1x		428 0033 30
			 right; ORGA →13383		553 0272 10
			 right; ORGA →13383		821 0465 10
			 left; ORGA →13383		821 0470 10
			 left; ORGA →13383		821 0464 10
			 82 mm		821 0469 10
			 ; ABS		713 6401 80
			 ; ABS ; ORGA 08099→		713 6305 30
			 ; G5		713 6404 20
			 ; G5 ; BE4R		772 0292 30
			 ;		772 0444 30
			 ;		815 0004 30
			 ;		815 0005 30
			 818 0278 10		818 0278 10
			 ⇄ ; ORGA →13383		825 0223 10
			 ; ; STANDARD		830 0038 30
			 ; 2x		830 0039 30
			 50,17 mm		
			 ; 2x		830 0042 30
			 50,2 mm		
			 ; + 965900; OPTION		830 0051 30
			 ; + 965901; OPTION		
			 840 0264 10		840 0264 10
			 840 0922 10		840 0922 10
			 623 3325 00		623 3325 00
1.6 HDi 110 9HL (DV6C); 9HR (DV6C); (82kW)	07.10-	 	+ ; ;		530 0578 10
			+ ; ;		530 0612 10
			+ ; ;		530 0578 30
			+ ; ;		530 0612 30
			+ ; ;		531 0850 10
			+ ; ;		531 0884 10
					532 0624 10
			 ; A/C		529 0261 10
			 ; A/C START/STOP		532 0773 10
			 ;		534 0075 20
			 # F-236591.05/07		535 0194 10
					544 0104 10
					544 0104 20
			 ; A/C		FB 6PK800
					538 0037 10
			8x		420 0086 10
			 12 mm		
			8x		422 0018 10
			1x		428 0183 10
		FAG	 right		821 0429 10
			 left		821 0428 10
			 82 mm		713 6307 60
			 62 mm		713 6406 10
			 ; G5 ; BE4R		772 0444 30
			 ;		815 0071 30
			 818 0243 10		818 0243 10
			 825 0192 10		825 0192 10
			 840 0321 10		840 0321 10
			 right		840 1018 10
			 left		840 1017 10
1.6 HDi 115 9HL (DV6C); (84kW)	07.10-		 		
		+ ; ;			530 0578 10
			+ ; ;		530 0612 10
			+ ; ;		530 0578 30
			+ ; ;		530 0612 30
			+ ; ;		531 0850 10
			+ ; ;		531 0884 10



			SCHAEFFLER
--	--	--	-------------------

CITROËN

BERLINGO





































<p>1.6 HDi 115 </p>	<p>07.10-</p>		<p> ; A/C  ; A/C START/STOP  # F-236591.05/.07  ; A/C 8x  12 mm 8x 1x FAG  82 mm  62 mm  ; G5 ; BE4R  right  left</p>	<p> 532 0624 10  529 0261 10  532 0773 10  534 0075 20  535 0194 10  544 0104 10  544 0104 20  FB 6PK800  538 0037 10  420 0086 10  422 0018 10  428 0183 10  713 6307 60 Set  713 6406 10 Set  772 0444 30 SET  815 0071 30 REP  818 0243 10  825 0192 10  840 0321 10  840 1018 10  840 1017 10</p>
<p>1.6 HDi 115 4x4 </p>	<p>02.12-</p>		<p> right  left  82 mm  62 mm  REP  818 0243 10  840 0321 10  840 1018 10  840 1017 10</p>	<p> 530 0698 10  530 0698 30  420 0086 10  422 0018 10  428 0183 10  821 0429 10  821 0428 10  713 6307 60 Set  713 6406 10 Set  815 0071 30 REP  818 0243 10  840 0321 10  840 1018 10  840 1017 10</p>
<p>1.6 VTi 120 </p>	<p>11.09-</p>		<p> ; A/C  ; A/C  ; A/C  532 0912 10  532 0676 10  534 0425 10  # F-560565.XX  # F-556533.XX  # F-560968.XX  EP6C DTR 8x;  12 mm 8x;  12 mm  422 0221 10  422 0222 10  422 0223 10  422 0224 10  422 0225 10 8x;  12 mm 1x 1x FAG  right  left  82 mm  62 mm</p>	<p> 529 0266 10  529 0308 10  531 0866 10  532 0912 10  532 0676 10  534 0425 10  535 0166 10  535 0178 10  535 0193 10  544 0096 10  538 0466 10  420 0226 10  420 0229 10  422 0221 10  422 0222 10  422 0223 10  422 0224 10  422 0225 10  422 0226 10  553 0237 10 OILP  559 0104 10 KIT  821 0429 10  821 0428 10  713 6307 60 Set  713 6406 10 Set</p>





























			SCHAEFFLER
--	---	--	-------------------

CITROËN

BERLINGO

1.6 VTi 120 5FS (EP6C); (88kW)	11.09-	FAG	5FS; G5; BE4R right left	 772 0444 30  815 0071 30  818 0243 10  825 0192 10  840 0321 10  840 1018 10  840 1017 10	1.6 BlueHDi 120 BHZ (DV6FC); (88kW)	12.14-	LUK  FAG	SAC incl.  ; A/C START START # 920725 1008725 START ; A/C DV6F_ 8x 12 mm 8x 1x right left 82 mm 62 mm 5FS; G6; BE4R right left	 624 3992 33  415 0743 10  530 0698 10  530 0698 30  531 0829 10  532 0624 10  529 0335 10  534 0654 10  534 0655 10  535 0308 10  FB 6APK1005  FB 6PK800  538 0037 10  420 0086 10  422 0018 10  428 0183 10  821 0429 10  821 0428 10  713 6307 60  713 6406 10  772 0444 30  815 0071 30  818 0243 10  825 0192 10  840 0321 10  840 1018 10  840 1017 10
-----------------------------------	--------	------------	--------------------------------	---	--	--------	---	--	--

JUMPER I (230)

2.0 HDI RHV (DW10TD); (62kW)	11.01-04.02	LUK  FAG	DW10TD; MLGU ; A/C ; A/C ; A/C # F-229603.XX # F-232369/.02/.03 F-232369.09/.11 A/C A/C ; A/C ; A/C 1x right; 16" right; 15" left; 16" left; 15" ; 1.000 kg → 1.400 kg 84 mm ; 1.800kg 90 mm 75 mm ; → 1.400 kg 100 mm	 623 3141 00  530 0111 10  530 0111 30  531 0264 10  532 0196 10  531 0373 10  532 0335 10  534 0110 20  534 0111 20  535 0039 10  535 0179 10  544 0039 10  544 0039 20  FB 4PK755  FB 6PK1183  FB 6PK1468  538 0008 10  428 0034 30  821 0810 10  821 0859 10  821 0809 10  821 0858 10  713 6403 90  713 6404 00  713 6403 30  771 0060 30
---------------------------------	-------------	---	---	--



			<p>SCHAEFFLER</p>
--	--	--	--------------------------















































CITROËN

JUMPER I (230)

2.0 HDi
 RHV (DW10TD); (62kW)

11.01-04.02

FAG

 ;  1.800kg;  5235558 →		771 0065 30
 122 mm		
 ;  MANU ;  1.000 kg →  1.400 kg		771 0036 30
 100 mm		
 ;  1.800kg;  →5235557		771 0052 30
 115 mm		
 ;  1.000 kg →  1.400 kg;  MANU		772 0254 30
 right;  →5616153		815 0058 30
 left;  5616154 →		
 left;  →5616153		815 0059 30
 right;  5616154 →		
		818 0226 10
 ;  15 "		825 0318 10
 ;  16 "		825 0319 10
		840 0238 10
		840 0285 10
		840 0286 10
		840 0926 10









































































































JUMPER II (244)

2.0 HDi
 RHV (DW10UTD); (62kW)

04.02-

LUK

























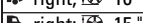

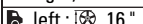

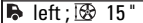



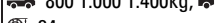



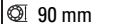





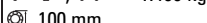



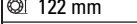



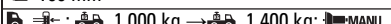





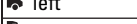





























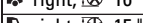

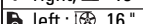

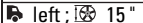



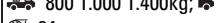









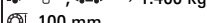



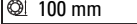

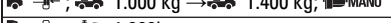







		623 3043 00
		530 0111 10
		530 0111 30
		531 0264 10
		532 0196 10
		531 0373 10
 ; A/C		532 0335 10
 ; →05.04; A/C		
 ; →05.04; A/C		534 0110 20
 ; A/C		534 0111 20
 ; 05.04 →; A/C		
 # F-229603.XX		535 0039 10
 # F-232369.04/.05/.07 F-232369.08		535 0059 10
 # F-236591.01/.02/.04 F-236591.06		535 0062 10
 # F-232369/.02/.03 F-232369.09/.11		535 0179 10
 # F-236591.05/.07		535 0194 10
 →04.04; A/C		544 0039 10
 →04.04; A/C		544 0039 20
		FB 4PK755
 ; A/C		FB 6PK1183
 ; →05.04; A/C		FB 6PK1468
 ; 05.04 →; A/C		FB 6PK875
		538 0008 10
1x		428 0034 30
FAG  right;  16 "		821 0810 10
 right;  15 "		821 0859 10
 left;  16 "		821 0809 10
 left;  15 "		821 0858 10
		713 0400 20
 800 1.000 1.400kg; 		Set 713 6403 90
 84 mm		Set 713 6404 00
 1.800kg; 		Set 713 6403 30
 90 mm		
 75 mm		771 0060 30
 ;  → 1.400 kg		771 0036 30
 100 mm		
 ;  MANU ;  1.000 kg →  1.400 kg		772 0254 30
 ;  1.000 kg →  1.400 kg;  MANU		772 0327 30
 ;  1.800kg		814 0128 10
 right		814 0127 10
 left		818 0226 10
		825 0318 10
 ;  15 "		825 0319 10
 ;  16 "		840 0238 10
		840 0285 10
		840 0286 10
		840 0999 10



			SCHAEFFLER
--	--	--	-------------------

CITROËN

JUMPER II (244)

























































































































2.0 XU10J2; (81kW)	04.02-	 	 MLGU	 624 3401 00
				 530 0233 10
			 ; A/C	 531 0047 10
			 ; A/C	 531 0096 10
			 8x	 FB 4PK755
			 38 mm	 FB 6PK1093
		FAG	 right; 16 "	 538 0468 10
			 right; 15 "	 421 0010 10
			 left; 16 "	 821 0810 10
			 left; 15 "	 821 0859 10
			 800 1.000 1.400kg;	 821 0809 10
			 84 mm	 821 0858 10
			 1.800kg;	 713 0400 20
			 90 mm	 713 6403 90
			 75 mm	 713 6404 00
			 → 1.400 kg	 713 6403 30
			 100 mm	 771 0060 30
			 1.800kg	 771 0065 30
			 122 mm	 771 0036 30
			 1.000 kg → 1.400 kg	 771 0036 30
			 100 mm	 771 0036 30
			 1.000 kg → 1.400 kg; MANU	 772 0254 30
			 1.800kg	 772 0327 30
			 right	 814 0128 10
			 left	 814 0127 10
			 15 "	 818 0226 10
			 16 "	 825 0318 10
			 16 "	 825 0319 10
			 840 0238 10	
			 840 0285 10	
			 840 0286 10	
			 840 0999 10	
			 624 3401 00	
2.0 bivalent XU10J2; (81kW)	02.03-	 	 MLGU	 624 3401 00
				 530 0233 10
			 ; A/C	 531 0047 10
			 ; A/C	 531 0096 10
			 8x	 FB 4PK755
			 38 mm	 FB 6PK1093
		FAG	 right; 16 "	 538 0468 10
			 right; 15 "	 421 0010 10
			 left; 16 "	 821 0810 10
			 left; 15 "	 821 0859 10
			 800 1.000 1.400kg;	 821 0809 10
			 84 mm	 821 0858 10
			 1.800kg;	 713 0400 20
			 90 mm	 713 6403 90
			 75 mm	 713 6404 00
			 → 1.400 kg	 713 6403 30
			 100 mm	 771 0060 30
			 1.800kg	 771 0036 30
			 1.000 kg → 1.400 kg; MANU	 771 0036 30
			 100 mm	 771 0036 30
			 1.000 kg → 1.400 kg; MANU	 772 0254 30
			 1.800kg	 772 0327 30
			 right	 814 0128 10
			 left	 814 0127 10
			 15 "	 818 0226 10
			 16 "	 825 0318 10
			 16 "	 825 0319 10
			 840 0238 10	



			SCHAEFFLER
--	--	--	-------------------

CITROËN

JUMPER II (244)















































2.0 bivalent  XU10J2; (81kW)	02.03-	FAG 	 ; 		840 0285 10			
					840 0286 10			
2.2 HDi  4HY (DW12UTED); (74kW)	02.02-06.06	LUK 	 MLGU		625 3023 00			
			→04.04		530 0368 10			
			04.04 →		530 0447 10			
			→04.04		530 0368 30			
			04.04 →		530 0447 30			
			→04.04		531 0264 10			
			04.04 →		531 0769 10			
			→04.04		532 0196 10			
			04.04 →		532 0460 10			
			 ; →05.04		531 0373 10			
			 ; A/C		532 0335 10			
			 ; →05.04; A/C					
			 ; →05.04; A/C		534 0110 20			
			 ; A/C		534 0111 20			
			 ; 05.04 →; A/C					
			 # F-229603.XX		535 0039 10			
			 # F-236591.01/.02/.04 F-236591.06		535 0062 10			
			A/C		544 0039 10			
			A/C		544 0039 20			
					FB 4PK755			
			 ; A/C		FB 6PK1183			
			 ; →05.04; A/C		FB 6PK1468			
			 ; 05.04 →; A/C		FB 6PK875			
					538 0428 10			
			1x		428 0034 30			
			1x		553 0128 10			
			FAG			 right;  16 "		821 0810 10
						 right;  15 "		821 0859 10
 left;  16 "		821 0809 10						
 left;  15 "		821 0858 10						
		713 0400 20						
 800 1.000 1.400kg; 		713 6403 90						
 84 mm		713 6404 00						
 1.800kg; 		713 6403 30						
 90 mm		713 6403 30						
 75 mm		771 0060 30						
 → 1.400 kg		771 0036 30						
 100 mm		772 0254 30						
 ;  MANU ;  1.000 kg →  1.400 kg		772 0327 30						
 100 mm		814 0128 10						
 ;  1.000 kg →  1.400 kg;  MANU		814 0127 10						
 ;  1.800kg		818 0226 10						
right		825 0318 10						
left		825 0319 10						
 15 "		840 0238 10						
 16 "		840 0285 10						
		840 0286 10						
		840 0999 10						
		625 3023 00						
LUK 	04.02-					 MLGU		625 3023 00
						→04.04		530 0368 10
						04.04 →		530 0447 10
						→04.04		530 0368 30
						04.04 →		530 0447 30
			→04.04		531 0264 10			
			04.04 →		531 0769 10			
			→04.04		532 0196 10			
			04.04 →		532 0460 10			
			 ; →05.04		531 0373 10			
			 ; A/C		532 0335 10			
			 ; →05.04; A/C					
			 ; →05.04; A/C		534 0110 20			



			SCHAEFFLER
--	---	--	-------------------

CITROËN

JUMPER II (244)



































































































































































2.2 HDi 4HY (DW12UTED); (74kW)	04.02-		A/C		534 0111 20	
			A/C ; 05.04 →; A/C		535 0039 10	
			F-229603.XX		535 0062 10	
			F-236591.01/.02/.04 F-236591.06		535 0179 10	
			F-232369/.02/.03 F-232369.09/.11		535 0194 10	
			F-236591.05/.07		544 0039 10	
			A/C		544 0039 20	
			A/C		FB 4PK755	
			A/C ; A/C		FB 6PK1183	
			A/C ; →05.04; A/C		FB 6PK1468	
			A/C ; 05.04 →; A/C		FB 6PK875	
			1x		538 0428 10	
			1x		428 0034 30	
			FAG	right; 16 "		553 0128 10
				right; 15 "		821 0810 10
		left; 16 "			821 0859 10	
		left; 15 "			821 0809 10	
		800 1.000 1.400kg; 84 mm			821 0858 10	
		1.800kg; 90 mm			713 0400 20	
		75 mm			713 6403 90	
		→ 1.400 kg			713 6404 00	
		1.800kg; 90 mm			713 6403 30	
		75 mm			771 0060 30	
		→ 1.400 kg			771 0065 30	
		1.800kg; 122 mm			771 0036 30	
		1.000 kg → 1.400 kg			772 0254 30	
		1.800kg; 100 mm			772 0327 30	
		right			814 0128 10	
		left			814 0127 10	
		15 "			818 0226 10	
16 "		825 0318 10				
825 0319 10		825 0319 10				
840 0238 10		840 0238 10				
840 0285 10		840 0285 10				
840 0286 10		840 0286 10				
840 0999 10		840 0999 10				
2.8 HDi 4x4 F28TDCR; (94kW)	02.02-06.06			VF7#; MLGU		624 3165 00
				OPTION	530 0117 10	
			530 0601 10			
			531 0557 10			
			532 0239 20			
		533 0114 10				
		531 0749 10				
		531 0812 10				
		532 0294 10				
		535 0039 10				
		FB 5PK1100				
		FB 6PK948				
		FB 6PK995				
		538 0469 10				
		428 0080 10				
		FAG	right; 16 "		821 0810 10	
			right; 15 "		821 0859 10	
			left; 16 "		821 0809 10	
			left; 15 "		821 0858 10	
			713 0400 20		713 0400 20	
			800 1.000 1.400kg; 84 mm		713 6403 90	
			1.800kg; 90 mm		713 6404 00	
			84 mm		713 6909 60	



			<p>SCHAEFFLER</p>
--	--	--	--------------------------

CITROËN

JUMPER II (244)

<p>2.8 HDi 4x4 F28TDCR; (94kW)</p>	<p>02.02-06.06</p>	<p>FAG</p>	<p> → 1.400 kg  100 mm   1.000 kg →  1.400 kg  100 mm   1.000 kg →  1.400 kg;   right  left  ;  15" ;  16"  ;   </p>	<p> 771 0060 30  771 0036 30  772 0254 30  814 0128 10  814 0127 10  818 0226 10  825 0318 10  825 0319 10  840 0238 10  840 0285 10  840 0286 10  840 0999 10</p>
<p>2.8 HDi 8140.43S; (94kW)</p>	<p>04.02-</p>	<p>LUK </p>	<p> VF7#;  MLGU OPTION      A/C;  → 3980846  A/C;  3980847 → ;  AUTOM  # F-229603.XX  A/C ;  AUTOM   FAG  right;  16"  right;  15"  left;  16"  left;  15"   800 1.000 1.400kg;   84 mm  1.800kg;   90 mm   75 mm  → 1.400 kg  100 mm   1.800kg   1.000 kg →  1.400 kg  100 mm   1.000 kg →  1.400 kg;    1.800kg  right  left  ;  15" ;  16"  ;   ;   </p>	<p> 624 3165 00  530 0117 10  530 0601 10  531 0557 10  532 0239 20  533 0114 10  531 0749 10  531 0812 10  532 0294 10  535 0039 10  FB 5PK1100  FB 6PK948  FB 6PK995  538 0469 10  428 0080 10  821 0810 10  821 0859 10  821 0809 10  821 0858 10  713 0400 20  713 6403 90  713 6404 00  713 6403 30  771 0060 30  771 0065 30  771 0036 30  772 0254 30  772 0327 30  814 0128 10  814 0127 10  818 0226 10  825 0318 10  825 0319 10  840 0238 10  840 0285 10  840 0286 10  840 0999 10</p>
<p>2.8 HDi 4x4 8140.43S; (94kW)</p>	<p>04.02-</p>	<p>LUK </p>	<p> VF7#;  MLGU OPTION      A/C;  → 3980846  A/C;  3980847 → ;  AUTOM  # F-229603.XX  A/C </p>	<p> 624 3165 00  530 0117 10  530 0601 10  531 0557 10  532 0239 20  533 0114 10  531 0749 10  532 0294 10  535 0039 10  FB 5PK1100  FB 6PK948</p>













































































			SCHAEFFLER
--	--	--	-------------------

CITROËN

JUMPER II (244)















































































2.8 HDi 4x4
 8140.43S; (94kW)

04.02-

	 ;  AUTOM		FB 6PK995
			538 0469 10
			428 0080 10
FAG	 right;  16 "		821 0810 10
	 right;  15 "		821 0859 10
	 left;  16 "		821 0809 10
	 left;  15 "		821 0858 10
			713 0400 20
	 800 1.000 1.400kg; 	 Set	713 6403 90
	 84 mm		
	 1.800kg; 	 Set	713 6404 00
	 90 mm		
		 Set	713 6909 60
	 84 mm		
	 ;  → 1.400 kg		771 0060 30
	 100 mm		
	 ;  1.800kg		771 0065 30
	 122 mm		
	 ;  MANU ;  1.000 kg →  1.400 kg		771 0036 30
	 100 mm		
	 ;  1.000 kg →  1.400 kg;  MANU	 SET	772 0254 30
	 ;  1.800kg	 SET	772 0327 30
	 right		814 0128 10
 left		814 0127 10	
		818 0226 10	
 ;  15 "		825 0318 10	
 ;  16 "		825 0319 10	
		840 0238 10	
 ; 		840 0285 10	
 ; 		840 0286 10	
		840 0999 10	

2.8 HDi All-wheel Drive
 2.8 HDi Allrad
 2.8 HDi A las 4 ruedas
 2.8 HDi Traction intégrale
 2.8 HDi Trazione integrale
 2.8 HDi Napęd na 4 koła
 2.8 HDi Привод на все колеса
 8140.43S; (94kW)

04.02-

	 VF7#;  MLGU		624 3165 00	
	OPTION		530 0117 10	
			530 0601 10	
			531 0557 10	
			532 0239 20	
			533 0114 10	
			531 0749 10	
			531 0812 10	
			532 0294 10	
			535 0039 10	
			FB 5PK1100	
			FB 6PK948	
			FB 6PK995	
			538 0469 10	
			428 0080 10	
	FAG	 right;  16 "		821 0810 10
		 right;  15 "		821 0859 10
		 left;  16 "		821 0809 10
		 left;  15 "		821 0858 10
		 800 1.000 1.400kg; 	 Set	713 6403 90
		 84 mm		
 1.800kg; 		 Set	713 6404 00	
 90 mm				
		 Set	713 6909 60	
 84 mm				
 ;  → 1.400 kg			771 0060 30	
 100 mm				
 ;  MANU ;  1.000 kg →  1.400 kg			771 0036 30	
 100 mm				
 ;  1.000 kg →  1.400 kg;  MANU		 SET	772 0254 30	
 ;  1.800kg		 SET	772 0327 30	
			818 0226 10	
 ;  15 "			825 0318 10	
 ;  16 "			825 0319 10	
			840 0238 10	
 ; 		840 0285 10		
 ; 		840 0286 10		
		840 0999 10		



			<p>SCHAEFFLER</p>
--	---	--	--------------------------

CITROËN

JUMPER II (244)

<p>2.8 HDi 8140.43N; (107kW)</p>	<p>05.04-</p>	<p>LUK INA</p>	<p>MLGU</p> <p>OPTION</p> <p>A/C ; →3980846 A/C ; 3980847→ AUTOM # F-229603.XX A/C AUTOM</p> <p>FAG</p> <p>right; 16" right; 15" left; 16" left; 15" 800 1.000 1.400kg; 84 mm 1.800kg; 90 mm 75 mm ; → 1.400 kg 100 mm ; MANU ; 1.000 kg → 1.400 kg 100 mm ; 1.000 kg → 1.400 kg; MANU ; 1.800kg right left 15" 16" 16x 12 mm 16x</p>	<p>624 3165 00 530 0117 10 530 0601 10 531 0557 10 532 0239 20 533 0114 10 531 0749 10 531 0812 10 532 0294 10 535 0039 10 FB 5PK1100 FB 6PK948 FB 6PK995 538 0469 10 428 0080 10 821 0810 10 821 0859 10 821 0809 10 821 0858 10 713 0400 20 Set 713 6403 90 Set 713 6404 00 Set 713 6403 30 771 0060 30 771 0036 30 SET 772 0254 30 SET 772 0327 30 814 0128 10 814 0127 10 818 0226 10 825 0318 10 825 0319 10 840 0238 10 840 0285 10 840 0286 10 840 0999 10</p>
---	---------------	---------------------------------------	---	--

JUMPER III













































































































<p>2.0 BlueHDi 110 2.0 BlueHDi 130 2.0 BlueHDi 160 AHM (DW10FUE); AHN (DW10FUD); AHP (DW10FUC); (81-120kW)</p>	<p>07.15-09.19</p>	<p>LUK INA</p>	<p>SAC</p> <p>OPTION</p> <p>START # F-602952.XX</p> <p>16x 12 mm 16x</p> <p>FAG</p> <p>right left 90 mm ; 1.600 2.000kg; ; 1.200 1.400 1.600kg; ; ; ; ; ; ; OPTION</p>	<p>626 3075 00 530 0691 10 530 0691 30 531 0885 10 532 0473 10 529 0310 10 535 0317 10 544 0097 10 544 0097 20 538 0077 10 420 0234 10 422 0107 10 SKIT 559 0106 10 821 0628 10 821 0627 10 Set 713 6405 50 Set 713 6405 60 Set 713 6405 70 814 0157 10 814 0158 10 818 0012 10 818 0479 10 818 0473 10 818 0480 10</p>
---	--------------------	---------------------------------------	---	--



			SCHAEFFLER
--	--	--	-------------------

CITROËN

JUMPER III

2.0 BlueHDi 110 2.0 BlueHDi 130 2.0 BlueHDi 160 AHM (DW10FUE); AHN (DW10FUD); AHP (DW10FUC); (81-120kW)	07.15-09.19	FAG 	 ↔		825 0277 10		
			 ↔		840 0388 10		
			 right		840 1050 10		
			 left		840 1055 10		
			SAC		626 3075 00		
		2.0 BlueHDi 110 2.0 BlueHDi 130 2.0 BlueHDi 160 AHM (DW10FUE); AHN (DW10FUD); AHP (DW10FUC); (81-120kW)	04.16-09.19	LUK 		530 0691 10	
						530 0691 30	
						531 0885 10	
						532 0473 10	
						529 0310 10	
						535 0317 10	
					# F-602952.XX		544 0097 10
						544 0097 20	
						538 0077 10	
					16x  12 mm		420 0234 10
16x				422 0107 10			
FAG	 right				821 0628 10		
	 left				821 0627 10		
					713 6405 50		
	 90 mm				713 6405 60		
	 ;  1.600 2.000kg; 				713 6405 70		
	 ;  1.200 1.400 1.600kg; 				814 0157 10		
					814 0158 10		
					818 0012 10		
	 ↔				818 0479 10		
	 ↔;  ; OPTION				818 0480 10		
	 ↔				825 0277 10		
	 ↔				840 0388 10		
	 right				840 1050 10		
	 left				840 1055 10		
	2.0 BlueHDi 130 4x4 2.0 BlueHDi 160 4x4 AHN (DW10FUD); AHP (DW10FUC); (96-120kW)	04.16-09.19	LUK 		626 3075 00		
				530 0691 10			
				530 0691 30			
				531 0885 10			
				532 0473 10			
				529 0310 10			
				535 0317 10			
# F-602952.XX					544 0097 10		
				544 0097 20			
				420 0234 10			
16x  12 mm				422 0107 10			
16x				821 0628 10			
FAG			 right		821 0627 10		
					814 0157 10		
					814 0158 10		
			818 0012 10				
	 ↔		818 0479 10				
 ↔		825 0277 10					
 ↔		840 0388 10					
 right		840 1050 10					
 left		840 1055 10					
2.2 HDi 100 4HV (P22DTE); (74kW)	04.06-	LUK 	SAC		624 3303 00		
			  ; A/C für Fahrzeuge mit hydraulischer Servolenkung		529 0301 10		
		  ; A/C für Fahrzeuge mit hydraulischer Servolenkung		529 0301 30			
		 ; A/C		532 0470 10			
		 ; A/C		532 0477 10			
		 ; A/C		534 0308 10			
		# F-554766.XX		535 0160 10			
				FB 4EPK922			
		 ; A/C		FB 6EPK873			
 ; A/C		FB 6PK1670					



			<p>SCHAEFFLER</p>
--	--	--	--------------------------

CITROËN

JUMPER III

























































































































































<p>2.2 HDi 100  4HV (P22DTE); (74kW)</p>	<p>04.06-</p>		<p>1x   538 0465 10 1x   558 0063 10 1x   559 0193 10 1x   559 0193 30 FAG  right  821 0628 10  left  821 0627 10   713 6405 50  90 mm  ;  1.600 2.000kg;   713 6405 60  ;  1.200 1.400 1.600kg;   713 6405 70  ;   771 0573 30    814 0157 10    814 0158 10    818 0012 10  ↔  818 0479 10  ↔  818 0473 10  ↔;  ; OPTION  818 0480 10  ↔  825 0277 10  ↔  840 0388 10  right  840 1050 10  left  840 1055 10</p>	<p>538 0465 10 558 0063 10 559 0193 10 559 0193 30 821 0628 10 821 0627 10 713 6405 50 713 6405 60 713 6405 70 771 0573 30 814 0157 10 814 0158 10 818 0012 10 818 0479 10 818 0473 10 818 0480 10 825 0277 10 840 0388 10 840 1050 10 840 1055 10</p>
<p>2.2 HDi 110  4HG (P22DTE); (81kW)</p>	<p>07.11-</p>		<p>SAC   624 3303 00   ;  A/C für Fahrzeuge mit hydraulischer Servolenkung  529 0301 10  ;  A/C für Fahrzeuge mit hydraulischer Servolenkung   529 0301 30  ;  A/C  532 0470 10  ;  A/C  532 0477 10  ;  A/C   534 0308 10  # F-554766.XX  535 0160 10  DW12RU*  535 0317 10  # F-602952.XX   FB 4EPK922  ;  A/C  FB 6EPK873  ;  A/C  FB 6PK1670  22DT  538 0465 10 FAG  right  821 0628 10  left  821 0627 10   713 6405 50  90 mm  ;  1.600 2.000kg;   713 6405 60  ;  1.200 1.400 1.600kg;   713 6405 70    814 0157 10    814 0158 10    818 0012 10  ↔  818 0479 10  ↔  818 0473 10  ↔;  ; OPTION  818 0480 10  ↔  825 0277 10  ↔  840 0388 10  right  840 1050 10  left  840 1055 10</p>	<p>624 3303 00 529 0301 10 529 0301 30 532 0470 10 532 0477 10 534 0308 10 535 0160 10 535 0317 10 FB 4EPK922 FB 6EPK873 FB 6PK1670 538 0465 10 821 0628 10 821 0627 10 713 6405 50 713 6405 60 713 6405 70 814 0157 10 814 0158 10 818 0012 10 818 0479 10 818 0473 10 818 0480 10 825 0277 10 840 0388 10 840 1050 10 840 1055 10</p>
<p>2.2 HDi 120  4HU (P22DTE); (88kW)</p>	<p>04.06-</p>		<p>→12.10;  PUMA 22DT;  G6 ;  MLGUC14  600 0318 00 incl.  ; incl.   600 0318 00 →12.10;  G6 ;  MLGUC14  600 0318 00 incl.  ; incl.   600 0318 00 →12.10;  MLGUC14  600 0318 00 incl.  ; incl.   626 3032 00 →12.10;  MLGUC14  626 3032 00 SAC  626 3075 00 →12.10;  MLGUC14  626 3075 00 SAC  415 0372 10 →12.10  411 0120 10  PUMA 22DT  411 0120 10</p>	<p>600 0318 00 600 0318 00 600 0318 00 600 0318 00 626 3032 00 626 3032 00 626 3075 00 415 0372 10 411 0120 10 411 0120 10</p>



			SCHAEFFLER
--	---	--	-------------------

CITROËN

JUMPER III



































































































































2.2 HDi 120 4HU (P22DTE); (88kW)	04.06-		 ;  ; A/C für Fahrzeuge mit hydraulischer Servolenkung		529 0301 10	
			 ;  ; A/C für Fahrzeuge mit hydraulischer Servolenkung		529 0301 30	
			 ; A/C		532 0470 10	
			 ; A/C		532 0477 10	
			 ; A/C		534 0308 10	
			 # F-554766.XX		535 0160 10	
					FB 4EPK922	
			 ; A/C		FB 6EPK873	
			 ; A/C		FB 6PK1670	
					538 0465 10	
			1x		558 0063 10	
			1x		558 0066 10	
			1x		559 0193 10	
			1x		559 0193 30	
		FAG	 right		821 0628 10	
			 left		821 0627 10	
					713 6405 50	
			 90 mm		713 6405 60	
			 ;  1.600 2.000kg; 		713 6405 70	
			 ;  1.200 1.400 1.600kg; 		713 6405 70	
			 ; 		771 0573 30	
					814 0157 10	
					814 0158 10	
					818 0012 10	
					818 0479 10	
					818 0473 10	
			 ;  ;  ; OPTION		818 0480 10	
					825 0277 10	
					840 0388 10	
			 right		840 1050 10	
			 left		840 1055 10	
2.2 HDi 130 4HH (P22DTE); (96kW)	07.11-			 MLGUC14		626 3075 00
				 SAC		626 3075 00
				 ;  ; A/C für Fahrzeuge mit hydraulischer Servolenkung		529 0301 10
		 ;  ; A/C für Fahrzeuge mit hydraulischer Servolenkung			529 0301 30	
		 ; A/C			532 0470 10	
		 ; A/C			532 0477 10	
		 ; A/C			534 0308 10	
		 # F-554766.XX			535 0160 10	
		 DW12RU*			535 0317 10	
		 # F-602952.XX			535 0317 10	
					FB 4EPK922	
		 ; A/C			FB 6EPK873	
		 ; A/C			FB 6PK1670	
		 22DT			538 0465 10	
		FAG		 right		821 0628 10
				 left		821 0627 10
						713 6405 50
				 90 mm		713 6405 60
				 ;  1.600 2.000kg; 		713 6405 70
				 ;  1.200 1.400 1.600kg; 		713 6405 70
						814 0157 10
						814 0158 10
					818 0012 10	
					818 0479 10	
					818 0473 10	
			 ;  ;  ; OPTION		818 0480 10	
					825 0277 10	
					840 0388 10	
			 right		840 1050 10	
			 left		840 1055 10	
2.2 HDi 150 4HJ (P22DTE); (110kW)	07.11-			 PUMA C 110;  MLGUC14		626 3075 00
				 SAC		626 3075 00
				 MLGUC14		626 3075 00
				 SAC		626 3075 00
			 ;  ; A/C für Fahrzeuge mit hydraulischer Servolenkung		529 0301 10	



			SCHAEFFLER
--	---	--	-------------------

CITROËN































JUMPER III

<p>2.2 HDi 150 4HJ (P22DTE); (110kW)</p>	<p>07.11-</p>	<p></p>	<p> ; A/C für Fahrzeuge mit hydraulischer Servolenkung</p> <p> ; A/C</p> <p> ; A/C</p> <p> ; A/C</p> <p> # F-554766.XX</p> <p> DW12RU*</p> <p> # F-602952.XX</p> <p> FB 4EPK922</p> <p> ; A/C</p> <p> ; A/C</p> <p> 22DT</p> <p> right</p> <p> left</p> <p> 90 mm</p> <p> ; 1.600 2.000kg; </p> <p> ; 1.200 1.400 1.600kg; </p> <p> #</p> <p> #</p> <p></p> <p> ↔</p> <p> ↔</p> <p> ↔;  ; OPTION</p> <p> ↔</p> <p> right</p> <p> left</p>	<p> 529 0301 30</p> <p> 532 0470 10</p> <p> 532 0477 10</p> <p> 534 0308 10</p> <p> 535 0160 10</p> <p> 535 0317 10</p> <p> FB 4EPK922</p> <p> FB 6EPK873</p> <p> FB 6PK1670</p> <p> 538 0465 10</p> <p> 821 0628 10</p> <p> 821 0627 10</p> <p>  713 6405 50</p> <p>  713 6405 60</p> <p>  713 6405 70</p> <p> 771 0552 30</p> <p> 814 0157 10</p> <p> 814 0158 10</p> <p> 818 0012 10</p> <p> 818 0479 10</p> <p> 818 0473 10</p> <p> 818 0480 10</p> <p> 825 0277 10</p> <p> 840 0388 10</p> <p> 840 1050 10</p> <p> 840 1055 10</p>
<p>3.0 HDi 145 3.0 HDi 155 3.0 HDi 160 F1CE0481D (F30DT); F30DTE (F1CE3481N); (107-116kW)</p>	<p>09.06-</p>	<p></p> <p></p>	<p>SAC</p> <p> A/C</p> <p> # F-550532.XX F-556500.XX</p> <p> # F-559894.XX</p> <p> A/C</p> <p> right</p> <p> left</p> <p> 90 mm</p> <p> ; 1.600 2.000kg; </p> <p> ; 1.200 1.400 1.600kg; </p> <p> #</p> <p> #</p> <p></p> <p> ↔</p> <p> ↔</p> <p> ↔;  ; OPTION</p> <p> ↔</p> <p> ↔</p> <p> right</p> <p> left</p>	<p> 626 3033 33</p> <p> 415 0375 10</p> <p> 411 0170 10</p> <p> 529 0267 10</p> <p> 531 0812 10</p> <p> 535 0103 10</p> <p> 535 0176 10</p> <p> FB 4EPK1102</p> <p> 538 0472 10</p> <p> 821 0628 10</p> <p> 821 0627 10</p> <p>  713 6405 50</p> <p>  713 6405 60</p> <p>  713 6405 70</p> <p> 771 0552 30</p> <p> 814 0157 10</p> <p> 814 0158 10</p> <p> 818 0012 10</p> <p> 818 0479 10</p> <p> 818 0473 10</p> <p> 818 0480 10</p> <p> 825 0277 10</p> <p> 840 0388 10</p> <p> 840 1050 10</p> <p> 840 1055 10</p>
<p>3.0 HDi 180 F1CE3481E (F30DTE); (130kW)</p>	<p>07.11-</p>	<p></p> <p></p>	<p>SAC</p> <p> A/C</p> <p> # F-550532.XX F-556500.XX</p> <p> # F-559894.XX</p> <p> A/C</p> <p> F30DT</p> <p> right</p> <p> left</p>	<p> 626 3033 33</p> <p> 415 0375 10</p> <p> 411 0170 10</p> <p> 529 0267 10</p> <p> 531 0812 10</p> <p> 535 0103 10</p> <p> 535 0176 10</p> <p> FB 4EPK1102</p> <p> 538 0472 10</p> <p> 821 0628 10</p> <p> 821 0627 10</p>







































































































			SCHAEFFLER
--	--	--	-------------------

CITROËN

JUMPER III			
3.0 HDi 180 F1CE3481E (F30DTE); (130kW)	07.11-	FAG	 Set 713 6405 50  90 mm  ;  1.600 2.000kg;    ;  1.200 1.400 1.600kg;                 ;  ; OPTION      right  left

FIAT

































































DOBLO (263)			
1.3 D Multijet 263 A6.000; (55kW)	11.13-	LUK	EURO 6  622 3238 00  512 0437 10  ; A/C  529 0380 10   532 0907 10   534 0455 10  # F-557928.XX  535 0151 10  # F-558432.XX  535 0171 10  # F-583190  535 0311 10  ; A/C  FB 6PK1525 A/C  FB 6PK1670  538 0442 10 16x  420 0181 10  12 mm 16x  422 0064 10 FAG  821 0908 10  right  821 0893 10  left  713 6908 00   74 mm  ;   Set 713 6909 80  ;   Set 713 6909 90   818 0278 10     825 0380 10     840 0404 10  
1.3 D Multijet 225 A2.000; (59kW)	03.16-	LUK	EURO 6  622 3238 00  512 0437 10   532 0907 10  # F-237101.XX  535 0063 10  # F-557928.XX  535 0151 10  # F-583190  535 0311 10  ; A/C  FB 6PK1525 FAG  821 0908 10  right  821 0893 10  left  713 6908 00   74 mm  ;   Set 713 6909 80  ;   Set 713 6909 90   818 0278 10     825 0380 10     840 0404 10  
1.3 D Multijet 199 A3.000; 263 A2.000; (66kW)	02.10-	LUK	EURO 6  622 3238 00  512 0437 10  ; A/C  529 0380 10   532 0907 10   534 0455 10  # F-557928.XX  535 0151 10  # F-583190  535 0311 10  ; A/C  544 0029 10  ; A/C  FB 6PK1520  ; A/C  FB 6PK1525



			<p>SCHAEFFLER</p>
--	--	--	--------------------------

FIAT

DOBLO (263)











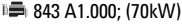







































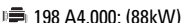

























































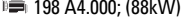

































<p>1.3 D Multijet 199 A3.000; 263 A2.000; (66kW)</p>	<p>02.10-</p>	<p></p>	<p>A/C 1x; 199 A3.000 1x 1x 1x 1x 1x 1x 1x right left 74 mm Set Set Set 818 0278 10 825 0380 10 840 0404 10</p>	<p> FB 6PK1670  538 0442 10  428 0030 30  559 0019 10  559 0027 30  559 0028 30  559 0053 10  559 0135 10  559 0146 10  821 0908 10  821 0893 10  713 6908 00  713 6909 80  713 6909 90  818 0278 10  825 0380 10  840 0404 10</p>
<p>1.3 D Multijet (263WXU1A) 330 A1.000; (70kW)</p>	<p>03.16-</p>	<p></p>	<p>F-237101.XX F-557928.XX F-583190 A/C 16x 12 mm 16x right left 74 mm Set Set 818 0278 10 825 0380 10 840 0404 10</p>	<p> 532 0907 10  535 0063 10  535 0151 10  535 0311 10  FB 6PK1525  420 0181 10  422 0064 10  821 0908 10  821 0893 10  713 6908 00  713 6909 80  713 6909 90  818 0278 10  825 0380 10  840 0404 10</p>
<p>1.4 843 A1.000; (70kW)</p>	<p>02.10-</p>	<p> </p>	<p>G5; C514.5 →11.13 A/C A/C 16x 28,38 mm right left 74 mm Set Set MANU 79 mm 79 mm →03.12 818 0278 10 825 0380 10 840 0404 10</p>	<p>GearBOX 462 0154 10  620 3445 00  530 0228 10  530 0228 30  531 0414 30  529 0013 10  FB 4PK668  538 0062 10  420 0210 10  821 0908 10  821 0893 10  713 6908 00  713 6909 80  713 6909 90  771 0073 30  771 0075 30  772 0276 30  818 0278 10  825 0380 10  840 0404 10</p>
<p>1.4 843 A1.000; (70kW)</p>	<p>04.10-</p>	<p> </p>	<p>G5; C514.5 →11.13 A/C A/C A/C</p>	<p>GearBOX 462 0154 10  620 3445 00  530 0228 10  530 0228 30  531 0414 30  529 0013 10  544 0030 10  FB 4PK668</p>



			SCHAEFFLER
--	---	--	-------------------

FIAT

DOBLO (263)



































































































































































































<p>1.4  843 A1.000; (70kW)</p>	<p>04.10-</p>		16x		538 0062 10
			 28,38 mm		420 0210 10
			FAG  right		821 0908 10
			 left		821 0893 10
			 	 Set	713 6908 00
			 74 mm	 Set	713 6909 80
			 	 Set	713 6909 90
			  		771 0073 30
			 79 mm		771 0075 30
			 79 mm		771 0075 30
			   	 SET	772 0276 30
			  		818 0278 10
			 		825 0380 10
			 		840 0404 10
			<p>1.4 Natural Power  198 A4.000; (88kW)</p>	<p>06.10-</p>	
		415 0678 10			
		411 0169 10			
		530 0228 10			
		530 0228 30			
		531 0414 30			
  ; A/C		529 0013 10			
  ; A/C ;  198A4.000		534 0069 10			
 # F-558432.XX		535 0171 10			
  ; A/C		FB 4PK668			
		538 0062 10			
16x		420 0210 10			
 28,38 mm		821 0908 10			
FAG  right		821 0893 10			
 left	 Set	713 6908 00			
 	 Set	713 6908 10			
 74 mm	 Set	713 6909 80			
 	 Set	713 6909 90			
  		771 0073 30			
 79 mm		771 0075 30			
   	 SET	772 0322 30			
  		818 0278 10			
 		818 0278 10			
 		825 0380 10			
 		840 0404 10			
<p>1.4  198 A4.000; (88kW)</p>	<p>10.11-</p>				622 3132 09
					530 0228 10
					530 0228 30
					531 0414 30
			  ; A/C		529 0013 10
			 		534 0069 10
			 # F-558432.XX		535 0171 10
			  ; A/C		FB 4PK668
					538 0062 10
			16x		420 0210 10
			 28,38 mm		821 0908 10
			FAG  right		821 0893 10
			 left	 Set	713 6908 00
			 	 Set	713 6908 10
			 74 mm	 Set	713 6909 80
 	 Set	713 6909 90			
  		771 0073 30			
 79 mm		771 0075 30			
   	 SET	772 0322 30			



			SCHAEFFLER
--	--	--	-------------------

FIAT

DOBLO (263)

























































































<p>1.4</p> <p> 198 A4.000; (88kW)</p>	10.11-	FAG	 ↔   ↔  ↔	   	<p>818 0278 10</p> <p>818 0278 10</p> <p>825 0380 10</p> <p>840 0404 10</p>					
	<p>1.6 D Multijet</p> <p> 263 A3.000; 263 A4.000; 263 A5.000; 263 A9.000; (66-74kW)</p>	02.10-	LUK	 SEMI ;  Selespeed  MANU SAC EURO 4 ; START/STOP EURO 5 EURO 6 ; START/STOP  Selespeed  MANU  SEMI ;  Selespeed	       	<p>623 3540 00</p> <p>624 3742 33</p> <p>415 0541 10</p> <p>415 0679 10</p> <p>415 0720 10</p> <p>411 0122 10</p> <p>411 0239 10</p>				
INA				                             	                             	<p>530 0561 10</p> <p>530 0561 30</p> <p>531 0844 10</p> <p>532 0611 10</p> <p>532 0505 10</p> <p>532 0617 10</p> <p>534 0610 10</p> <p>535 0112 10</p> <p>535 0181 10</p> <p>544 0080 20</p> <p>FB 6PK1370</p> <p>FB 6PK1708</p> <p>538 0714 10</p> <p>420 0181 10</p>				
				FAG	 right  left  ;   74 mm  ;   82,5 mm  ;   ;   ↔  ↔ ; →03.12   ↔  ↔	                                      	<p>821 0908 10</p> <p>821 0893 10</p> <p>713 6908 00</p> <p>713 6908 10</p> <p>713 6909 80</p> <p>713 6909 90</p> <p>771 0568 30</p> <p>772 0322 30</p> <p>818 0278 10</p> <p>825 0380 10</p> <p>840 0404 10</p>			
					LUK	 SEMI ;  Selespeed  MANU SAC EURO 4 ; START/STOP EURO 5 EURO 6 ; START/STOP  Selespeed  MANU  SEMI ;  Selespeed	                        	<p>623 3540 00</p> <p>624 3742 33</p> <p>415 0541 10</p> <p>415 0679 10</p> <p>415 0720 10</p> <p>411 0122 10</p> <p>411 0239 10</p>		
						INA	         	         	<p>530 0561 10</p> <p>530 0561 30</p> <p>531 0844 10</p> <p>532 0611 10</p> <p>532 0505 10</p> <p>532 0617 10</p> <p>534 0610 10</p> <p>535 0112 10</p> <p>535 0181 10</p> <p>544 0080 20</p> <p>FB 6PK1370</p> <p>FB 6PK1708</p> <p>538 0714 10</p> <p>420 0181 10</p>	
							FAG	 right		<p>821 0908 10</p>



			SCHAEFFLER
--	---	--	-------------------

FIAT

DOBLO (263)





















1.6 D Multijet 263 A3.000; 263 A9.000; (74kW)	02.10-	FAG	 left	 821 0893 10
			 ; 	 Set 713 6908 00
			 74 mm	 Set 713 6908 10
			 ; 	 Set 713 6909 80
			 82,5 mm	 Set 713 6909 90
			 ; 	771 0568 30
			 ; 	 SET 772 0322 30
			 ;  ; →03.12	818 0278 10
				825 0380 10
				840 0404 10
				623 3540 00
				624 3742 33
			 SAC	415 0541 10
			 EURO 4 ; START/STOP	415 0679 10
			 EURO 5	415 0720 10
			 EURO 6 ; START/STOP	411 0122 10
			 Selespeed	411 0239 10
 ;  Selespeed	530 0561 10			
	530 0561 30			
	531 0844 10			
	532 0611 10			
 ; A/C	532 0505 10			
	532 0617 10			
	534 0610 10			
 # F-238822.XX	535 0112 10			
 # F-565229.XX F-568861.XX	535 0181 10			
	544 0080 20			
 ; A/C	FB 6PK1370			
 ; A/C	FB 6PK1708			
	538 0714 10			
16x	420 0181 10			
 12 mm	422 0075 10			
16x	422 0075 10			
FAG	821 0908 10			
 right	821 0893 10			
 left	 Set 713 6908 00			
 ; 	 Set 713 6908 10			
 74 mm	 Set 713 6909 80			
 ; 	 Set 713 6909 90			
 ; 	771 0568 30			
 ; 	 SET 772 0322 30			
 ;  ; →03.12	818 0278 10			
	825 0380 10			
	840 0404 10			
	623 3540 00			
	624 3742 33			
 SAC	415 0541 10			
 EURO 4 ; START/STOP	415 0541 10			
 EURO 6 ; START/STOP	415 0679 10			
 EURO 6 ; START/STOP	415 0679 10			
 EURO 5	415 0720 10			
 EURO 6 ; START/STOP	415 0720 10			
 EURO 6 ;  Selespeed	411 0122 10			
 ;  Selespeed	411 0239 10			
	530 0561 10			
	530 0561 30			
	531 0844 10			
	532 0611 10			
1.6 D Multijet 940 C1.000; (88kW)	02.16-	LUK	 ;  Selespeed	623 3540 00
				624 3742 33
			 SAC	415 0541 10
			 EURO 4 ; START/STOP	415 0541 10
			 EURO 6 ; START/STOP	415 0679 10
			 EURO 6 ; START/STOP	415 0679 10
			 EURO 5	415 0720 10
			 EURO 6 ; START/STOP	415 0720 10
			 EURO 6 ;  Selespeed	411 0122 10
				411 0239 10
			 ;  Selespeed	530 0561 10
				530 0561 30
				531 0844 10
				532 0611 10





























			<p>SCHAEFFLER</p>
--	--	--	--------------------------



















FIAT

DOBLO (263)

<p>1.6 D Multijet i= 940 C1.000; (88kW)</p>	<p>02.16-</p>		<p>A/C</p> <p> 532 0505 10</p> <p> 532 0617 10</p> <p> 534 0610 10</p> <p> 535 0112 10</p> <p> 535 0181 10</p> <p> 544 0080 20</p> <p> FB 6PK1370</p> <p> FB 6PK1705</p> <p>16x  420 0181 10</p> <p> 422 0075 10</p> <p>FAG</p> <p> 821 0908 10</p> <p> 821 0893 10</p> <p> Set 713 6908 00</p> <p> Set 713 6908 10</p> <p> Set 713 6909 80</p> <p> Set 713 6909 90</p> <p> 818 0278 10</p> <p> 825 0380 10</p> <p> 840 0404 10</p>	
---	---------------	---	---	--

<p>2.0 D Multijet i= 263 A1.000; (99kW)</p>	<p>02.10-</p>		<p>SAC</p> <p> 624 3742 33</p> <p>incl.  415 0707 10</p> <p> 411 0122 10</p> <p> 530 0562 10</p> <p> 530 0562 30</p> <p> 531 0844 10</p> <p> 532 0611 10</p> <p> 532 0505 10</p> <p> 532 0617 10</p> <p> 534 0610 10</p> <p> 535 0112 10</p> <p> 535 0181 10</p> <p> 544 0080 20</p> <p> FB 6PK1370</p> <p> FB 6PK1705</p> <p> FB 6PK1708</p> <p> 538 0714 10</p> <p>16x  420 0181 10</p> <p>16x  422 0075 10</p> <p>FAG</p> <p> 821 0908 10</p> <p> 821 0893 10</p> <p> Set 713 6908 10</p> <p> Set 713 6909 90</p> <p> 818 0278 10</p> <p> 825 0380 10</p> <p> 840 0404 10</p>	
---	---------------	---	---	--

DOBLO Cargo (223)





















































































<p>1.2 (223ZA1A) i= 223 A5.000; (48kW)</p>	<p>03.01-</p>		<p> 618 3032 00</p> <p>  530 0206 10</p> <p>  530 0462 10</p> <p>  530 0206 30</p> <p>  531 0005 10</p> <p>  531 0778 10</p> <p>  544 0032 10</p> <p>  FB 3PK915</p> <p>  FB 4PK668</p> <p> FB 4PK673</p> <p> FB 4PK698</p> <p> FB 4PK840</p> <p> 538 0018 10</p> <p> 428 0149 10</p> <p>FAG</p> <p> 821 0377 10</p> <p> 821 0559 10</p> <p> 821 0725 10</p>	
--	---------------	---	--	--



			SCHAEFFLER
--	---	--	-------------------

FIAT

DOBLO Cargo (223)



<p>1.2 (223XA1A)  223 A5.000; (48kW)</p>	<p>03.01-</p>	<p>FAG</p>	<p> left; →09.05  821 0376 10</p> <p> left;  821 0560 10</p> <p> left; 09.05→  821 0724 10</p> <p>  713 0071 20</p> <p> ; ABS  Set 713 6064 00</p> <p> ; ABS  Set 713 6905 10</p> <p> 72 mm  Set 713 6907 30</p> <p> ; ABS  Set 713 6907 30</p> <p> 72,04 mm  Set 713 6907 30</p> <p>  Set 713 6907 30</p> <p> ;  MANU ; →11.03  771 0073 30</p> <p> 79 mm  772 0274 30</p> <p>  SET 772 0274 30</p> <p> right  814 0105 10</p> <p> ;  left  814 0106 10</p> <p> left  814 0106 10</p> <p> ;  right  818 0292 10</p> <p> ↔;  STANDARD  818 0345 10</p> <p> ↔;   825 0184 10</p> <p> Vett.5023343→;   825 0185 10</p> <p> →Vett.5023342;   840 0223 10</p> <p> ;   840 0229 10</p> <p> ; VET →5120133  840 0909 10</p> <p> ;  VET 5120134→  840 0908 10</p> <p> right;  VET 5120134→  840 0937 10</p> <p> left;  VET 5120134→  840 0937 10</p> <p> ;   840 0937 10</p> <p> ; VET →5120133  622 3238 00</p>
<p>1.3 JTD 16V  188 A8.000; 188 A9.000; (51kW)</p>	<p>05.04-12.06</p>	<p>LUK</p> <p></p>	<p> ; A/C ; +  529 0179 10</p> <p> ; A/C  529 0286 10</p> <p>  534 0607 10</p> <p> # F-237101.XX  535 0063 10</p> <p> # F-557928.XX  535 0151 10</p> <p>  544 0035 10</p> <p>  FB 4EPK1022</p> <p> ; A/C  FB 6PK1310</p> <p>  538 0442 10</p> <p>1x  428 0030 30</p> <p>1x  KIT 559 0019 10</p> <p>1x  KIT 559 0027 30</p> <p>1x  KIT 559 0028 30</p> <p>1x  KIT 559 0053 10</p> <p>1x  KIT 559 0135 10</p> <p>1x  KIT 559 0146 10</p> <p>FAG</p> <p> right; →09.05  821 0377 10</p> <p> right;  821 0559 10</p> <p> right; 09.05→  821 0725 10</p> <p> left; →09.05  821 0376 10</p> <p> left;  821 0560 10</p> <p> left; 09.05→  821 0724 10</p> <p>  713 0071 20</p> <p> ; ABS  Set 713 6064 00</p> <p> 72 mm  Set 713 6905 10</p> <p> ; ABS  Set 713 6905 10</p> <p> 72,04 mm  Set 713 6907 30</p> <p>  Set 713 6907 30</p> <p> ;  MANU  771 0078 30</p> <p> 84,5 mm  SET 772 0437 30</p> <p> ;  MANU  SET 772 0437 30</p> <p> right  814 0105 10</p> <p> ;  left  814 0106 10</p> <p> left  814 0106 10</p> <p> ;  right  818 0292 10</p> <p> ↔;  STANDARD  818 0345 10</p> <p> ↔;  825 0184 10</p> <p> Vett.5023343→; 825 0185 10</p> <p> →Vett.5023342; 825 0185 10</p>



			<p>SCHAEFFLER</p>
--	--	--	--------------------------

FIAT

DOBLO Cargo (223)





































































<p>1.3 JTD 16V 188 A8.000; 188 A9.000; (51kW)</p>	<p>05.04-12.06</p>	<p>FAG</p>	<p> ; ; →5120133 ; ; VET 5120134→ right; ; VET 5120134→ left; ; VET 5120134→ ; ; →5120133</p>	<p> 840 0223 10 840 0229 10 840 0909 10 840 0908 10 840 0937 10</p>
<p>1.3 D Multijet 199 A2.000; (55kW)</p>	<p>10.05-01.10</p>	<p>LUK  FAG</p>	<p> ; A/C ; + ; A/C # F-237101.XX # F-557928.XX ; A/C 1x 1x 1x 1x 1x 1x 1x right; ; right left; ; left ; ABS 72 mm ; ABS 72,04 mm →512071; MANU 84,5 mm →512071; MANU right ; left left ; right ↔; STANDARD ↔; Vett.5023343→; →Vett.5023342; ; →5120133 ; ; VET 5120134→ right; ; VET 5120134→ left; ; VET 5120134→ ; →5120133</p>	<p> 622 3238 00 512 0437 10 529 0179 10 529 0286 10 534 0607 10 535 0063 10 535 0151 10 544 0035 10 FB 4EPK1022 FB 6PK1310 538 0442 10 428 0030 30 559 0019 10 559 0027 30 559 0028 30 559 0053 10 559 0135 10 559 0146 10 821 0559 10 821 0725 10 821 0560 10 821 0724 10 713 6064 00 713 6905 10 713 6907 30 771 0078 30 772 0437 30 814 0105 10 814 0106 10 818 0292 10 818 0345 10 825 0184 10 825 0185 10 840 0223 10 840 0229 10 840 0909 10 840 0908 10 840 0937 10</p>
<p>1.3 JTD 16V Multijet 223 A9.000; (62kW)</p>	<p>08.06-</p>	<p>LUK </p>	<p>RHD ; A/C ; + # F-237101.XX # F-557928.XX ; A/C ; A/C 16x 12 mm 16x 1x 1x 1x 1x 1x 1x 1x</p>	<p> 622 3238 00 512 0437 10 529 0179 10 535 0063 10 535 0151 10 FB 4EPK1022 FB 6PK1180 FB 6PK1310 420 0181 10 422 0064 10 559 0019 10 559 0027 30 559 0028 30 559 0053 10 559 0135 10 559 0146 10</p>



			SCHAEFFLER
--	---	--	-------------------

FIAT

DOBLO Cargo (223)



1.3 JTD 16V Multijet i= 223 A9.000; (62kW)	08.06-	FAG	 right	 821 0725 10
			 left	 821 0724 10
1.4 i= 350 A1.000; (57kW)	10.05-	LUK	G5 ;  C514.5	GearBOX 462 0154 10
				 620 3445 00
1.6 16V (223XD1A) i= 182 B6.000; (76kW)	10.01-	LUK	G5 ;  C514.5	GearBOX 462 0154 10
				 620 3128 00
			 right;  left	 821 0559 10
			 right	 821 0725 10
			 left;  left	 821 0560 10
			 left	 821 0724 10
			 ABS	 Set 713 6064 00
			 72 mm	 Set 713 6905 10
			 ABS	 Set 713 6907 30
			 72,04 mm	 Set 713 6907 30
			 MANU	 771 0073 30
			 79 mm	 SET 772 0276 30
			 right	 814 0105 10
			 left	 814 0106 10
			 left	 814 0106 10
			 right	 818 0292 10
			 STANDARD	 818 0345 10
			 STANDARD	 825 0184 10
			 Vett.5023343 →;  left	 825 0185 10
			 →Vett.5023342;  left	 840 0223 10
			 	 840 0229 10
			 VET →5120133	 840 0909 10
			 VET 5120134 →	 840 0908 10
			 right;  VET 5120134 →	 840 0937 10
			 left;  VET 5120134 →	 840 0937 10
			 	 840 0937 10
			 VET →5120133	 840 0937 10



			<p>SCHAEFFLER</p>
--	--	--	--------------------------

FIAT









































































































DOBLO Cargo (223)

<p>1.6 16V (223ZXD1A) 182 B6.000; (76kW)</p>	<p>10.01-</p>		<p>16x 33 mm</p> <p>FAG</p> <p>right; →09.05 right; I right; 09.05→ left; →09.05 left; I left; 09.05→ ABS 72 mm ABS 72,04 mm MANU 79 mm right left left right I STANDARD I Vett.5023343→; →Vett.5023342; VET →5120133 VET 5120134→ right; VET 5120134→ left; VET 5120134→ VET →5120133 right; VET 5120134→</p>	<p>538 0448 10 538 0449 10 420 0050 10 821 0377 10 821 0559 10 821 0725 10 821 0376 10 821 0560 10 821 0724 10 713 0071 20 Set 713 6064 00 Set 713 6905 10 Set 713 6907 30 771 0073 30 SET 772 0276 30 814 0105 10 814 0106 10 818 0292 10 818 0345 10 825 0184 10 825 0185 10 840 0223 10 840 0229 10 840 0909 10 840 0908 10 840 0937 10</p>
<p>1.6 Natural Power 182 B6.000; (76kW)</p>	<p>09.02-</p>	<p>LUK</p> 	<p>G5; C514.5</p> <p>FAG</p> <p>right; →09.05 right; I right; 09.05→ left; →09.05 left; I left; 09.05→ ABS 72 mm ABS 72,04 mm MANU right left left right I STANDARD I Vett.5023343→; →Vett.5023342; VET →5120133 VET 5120134→ right; VET 5120134→</p>	<p>GearBOX 462 0154 10 620 3128 00 530 0222 10 531 0280 10 532 0209 10 531 0760 10 FB 5PK940 538 0448 10 538 0449 10 420 0050 10 821 0377 10 821 0559 10 821 0725 10 821 0376 10 821 0560 10 821 0724 10 713 6064 00 Set 713 6905 10 Set 713 6907 30 SET 772 0276 30 814 0105 10 814 0106 10 818 0292 10 818 0345 10 825 0184 10 825 0185 10 840 0223 10 840 0229 10 840 0909 10</p>



			SCHAEFFLER
--	--	--	-------------------

FIAT

DOBLO Cargo (223)						
1.6 Natural Power 182 B6.000; (76kW)	09.02-	FAG	left;  ; VET 5120134→  ;   ; VET →5120133	 840 0908 10		
			 840 0937 10			
1.9 D (223ZXB1A) 223 A6.000; (46kW)	03.01-	LUK 		 620 3080 00		
				 530 0623 10		
				 530 0623 30		
				 531 0844 10		
				 532 0287 10		
			 ; A/C	 532 0370 20		
				 534 0101 20		
			# F-554053.XX	 535 0115 10		
			→2235205	 544 0080 20		
				 FB 6PK1053		
			 A/C	 FB 6PK1815		
				 538 0013 10		
			8x  37 mm	 421 0012 10		
				 428 0100 10		
			FAG	right; →09.05	 821 0377 10	
			right; 	 821 0559 10		
			 ; right; 09.05→	 821 0725 10		
			left; →09.05	 821 0376 10		
			left; 	 821 0560 10		
			 ; left; 09.05→	 821 0724 10		
				 713 0071 20		
			 ; ABS  72 mm	 Set 713 6064 00		
			 ; ABS  72,04 mm	 Set 713 6905 10		
				 Set 713 6907 30		
			 ;  MANU; →11.03  79 mm	 771 0073 30		
				 SET 772 0274 30		
			right  left	 814 0105 10		
			left  right	 814 0106 10		
			 ↔;  STANDARD	 818 0292 10		
			 ↔; 	 818 0345 10		
			 Vett.5023343→; 	 825 0184 10		
			 →Vett.5023342; 	 825 0185 10		
 ; 	 840 0223 10					
 ; VET →5120133						
 ;  ; VET 5120134→	 840 0229 10					
right;  ; VET 5120134→	 840 0909 10					
left;  ; VET 5120134→	 840 0908 10					
 ; 	 840 0937 10					
 ; VET →5120133						
1.9 JTD (223XE1A) 182 B9.000; (74kW)	10.01-	LUK 	incl.  ; incl. 	 600 0216 00		
			oLuK	 623 3296 00		
			oValeo	 623 3540 00		
			+ 623 3296 00	 415 0694 10		
			+ 411 0122 10			
			+ 415 0393 10	 411 0122 10		
			+ 415 0694 10			
			RHD	 512 0437 10		
				 530 0622 10		
				 530 0622 30		
				 531 0844 10		
				 532 0287 10		
			 ; A/C	 532 0370 20		
				 534 0101 20		
			# F-230866.04/.05/.07 F-230866.10/.11/.13	 535 0023 10		
# F-554053.XX	 535 0115 10					
 ; A/C	 544 0080 20					
A/C	FB 6PK1053					
	FB 6PK1815					
	538 0013 10					



			<p>SCHAEFFLER</p>
--	--	--	--------------------------































































FIAT

DOBLO Cargo (223)

1.9 JTD (223ZXE1A)
 182 B9.000; (74kW)

10.01-



8x		421 0012 10
 37 mm		
1x		428 0139 10
FAG right; →09.05		821 0377 10
right; 		821 0559 10
 ; right; 09.05→		821 0725 10
left; →09.05		821 0376 10
left; 		821 0560 10
 ; left; 09.05→		821 0724 10
		713 0071 20
ABS		713 6064 00
 72 mm		
ABS		713 6905 10
 72,04 mm		
		713 6907 30
 ;  →5512071;  MANU		771 0078 30
 84,5 mm		
 ; →01.09;  MANU		772 0437 30
right		814 0105 10
 ; left		
left		814 0106 10
 ; right		
 ↔; STANDARD		818 0292 10
 ↔; 		818 0345 10
 Vett.5023343→; 		825 0184 10
 →Vett.5023342; 		825 0185 10
		840 0223 10
 ; VET →5120133		
 ;  ; VET 5120134→		840 0229 10
right;  ; VET 5120134→		840 0909 10
left;  ; VET 5120134→		840 0908 10
		840 0937 10
 ; VET →5120133		

1.9 JTD























223 A7.000; 223 B1.000; (77kW)

07.03-























incl.  ; incl. 		600 0216 00
LuK		623 3296 00
 3301741→; Valeo		623 3540 00
+ 623 3296 00		415 0694 10
+ 411 0122 10		
+ 415 0393 10		411 0122 10
+ 415 0694 10		



RHD		512 0437 10
		530 0622 10
		530 0622 30
		531 0844 10
→04.04		532 0287 10
04.04→		532 0611 10
 ; A/C		532 0370 20
		534 0101 20
 # F-554053.XX		535 0115 10
		544 0080 20
 		FB 6PK1053
  A/C		FB 6PK1815
		538 0013 10
8x;  223A7.000		421 0012 10
 37 mm		



















































































































		428 0139 10
FAG right; →09.05		821 0377 10
right; 		821 0559 10
 ; right; 09.05→		821 0725 10
left; →09.05		821 0376 10
left; 		821 0560 10
 ; left; 09.05→		821 0724 10
		713 0071 20
ABS		713 6064 00
 72 mm		
ABS		713 6905 10
 72,04 mm		
		713 6907 30













			SCHAEFFLER
--	---	--	-------------------

FIAT

DOBLO Cargo (223)

1.9 JTD 223 A7.000; 223 B1.000; (77kW)	07.03-	FAG	 →5512071; 		771 0078 30			
			 84,5 mm		772 0437 30			
			 right		814 0105 10			
			 left		814 0106 10			
			 left		814 0106 10			
			 right		814 0106 10			
			 STANDARD		818 0292 10			
					818 0345 10			
			 Vett.5023343→;		825 0184 10			
			 →Vett.5023342;		825 0185 10			
					840 0223 10			
			 ; VET →5120133		840 0229 10			
			 ;  ; VET 5120134→		840 0909 10			
			 right;  ; VET 5120134→		840 0908 10			
			 left;  ; VET 5120134→		840 0937 10			
			 ;		840 0937 10			
			 ; VET →5120133		840 0937 10			
			1.9 JTD Multijet 186 A9.000; (88kW)	12.06-	LUK	incl.  ; incl. 		600 0216 00
						 LuK		623 3296 00
						 Valeo		623 3540 00
 623 3296 00		415 0694 10						
 411 0122 10		415 0694 10						
 415 0393 10		411 0122 10						
 415 0694 10		411 0122 10						
RHD		512 0437 10						
		530 0622 10						
		530 0622 30						
		531 0844 10						
		532 0611 10						
 ; A/C		532 0370 20						
		534 0101 20						
 # F-554053.XX		535 0115 10						
		544 0080 20						
		538 0013 10						
8x		421 0012 10						
 37 mm		428 0139 10						
1x		821 0725 10						
FAG	 right		821 0725 10					
	 left		821 0724 10					
	 ; ABS		713 6064 00					
	 ; ABS		713 6905 10					
			713 6907 30					
	 →5512071; 		771 0078 30					
	 84,5 mm		772 0437 30					
	 →01.09; 		814 0106 10					
	 right		814 0105 10					
	 left		814 0105 10					
 STANDARD		818 0292 10						
		818 0345 10						
 Vett.5023343→;		825 0184 10						
 →Vett.5023342;		825 0185 10						
		840 0223 10						
 ; VET →5120133		840 0229 10						
 ;  ; VET 5120134→		840 0909 10						
 right;  ; VET 5120134→		840 0908 10						
 left;  ; VET 5120134→		840 0908 10						

DUCATO (230)

2.0 JTD RHV (DW10); (62kW)	07.01-04.02	LUK			623 3043 00
					530 0111 10
					530 0111 30
					531 0264 10
					532 0196 10
			 ; A/C		531 0373 10
					532 0335 10
 ; A/C		534 0110 20			



			<p>SCHAEFFLER</p>
--	---	--	--------------------------

































FIAT

DUCATO (230)

2.0 JTD
 RHV (DW10); (62kW)

07.01-04.02





























	A/C		534 0111 20	
	A/C		544 0039 10	
	A/C		544 0039 20	
	A/C		FB 4PK755	
	A/C		FB 6PK1180	
	A/C		FB 6PK1468	
			538 0008 10	
1x			428 0034 30	
FAG	right; 16"		821 0810 10	
	right; 15"		821 0859 10	
	left; 16"		821 0809 10	
	left; 15"		821 0858 10	
	; 11.01→; 6194400→; 1.000 kg → 1.400 kg		Set	713 6403 90
	84 mm			
	; 11.01→; 6194400→; 1.800kg		Set	713 6404 00
	90 mm			
	; →11.01; 6194399; 1.000 kg → 1.400 kg		Set	713 6503 10
	80 mm			
	; →11.01; 6194399; 1.800kg		Set	713 6503 30
	89,92 mm			
	; 11.01→; 6194400→		Set	713 6403 30
	75 mm			
	; →11.01; 6194399; 1.000 kg → 1.400 kg		Set	713 6504 20
	; →11.01; 6194399; 1.800kg		Set	713 6504 30
	; → 1.400 kg			771 0060 30
	100 mm			
	; 1.800kg; 5235558→			771 0065 30
	122 mm			
; MANU; 1.000 kg → 1.400 kg			771 0036 30	
100 mm				
; 1.000 kg → 1.400 kg; MANU		SET	772 0254 30	
; 6194400→; AUTOM		SET	772 0327 30	
↔			818 0226 10	
			818 0226 10	
; 15"			825 0318 10	
; 16"			825 0319 10	
			840 0238 10	
			840 0285 10	
			840 0286 10	
↔			840 0926 10	

2.0 JTD
 RHV (DW10); (62kW)

10.01-04.02





			623 3043 00	
			530 0111 10	
			530 0111 30	
			531 0264 10	
			532 0196 10	
	A/C		531 0373 10	
			532 0335 10	
	A/C		534 0110 20	
	A/C		534 0111 20	
	F-229603.XX		535 0039 10	
	F-232369.04/05/07 F-232369.08		535 0059 10	
	F-236591.05/07		535 0194 10	
	A/C		544 0039 10	
	A/C		544 0039 20	
	A/C		FB 4PK755	
	A/C		FB 6PK1180	
	A/C		FB 6PK1468	
			538 0008 10	
1x			428 0034 30	
FAG	right; 16"		821 0810 10	
	right; 15"		821 0859 10	
	left; 16"		821 0809 10	
	left; 15"		821 0858 10	
	; 11.01→; 6194400→; 1.000 kg → 1.400 kg		Set	713 6403 90
	84 mm			
	; 11.01→; 6194400→; 1.800kg		Set	713 6404 00
	90 mm			
	; →11.01; 6194399; 1.000 kg → 1.400 kg		Set	713 6503 10
	80 mm			



			SCHAEFFLER
--	---	--	-------------------

FIAT

DUCATO (230)











































































































<p>2.0 JTD  RHV (DW10); (62kW)</p>	<p>10.01-04.02</p>	<p>FAG</p>	<p> →11.01; →6194399; 1.800kg 89,92 mm ; 11.01→; 6194400→ 75 mm ; →11.01; →6194399; 1.000 kg → 1.400 kg ; →11.01; →6194399; 1.800kg ; → 1.400 kg 100 mm ; 1.800kg; 5235558→ 122 mm ; MANU ; 1.000 kg → 1.400 kg 100 mm ; 1.800kg; →5235557 115 mm ; 1.000 kg → 1.400 kg; MANU ; 6194400→; AUTOM right; →5616153 left; 5616154→ left; →5616153 right; 5616154→ ; 15 " ; 16 " ; ; </p>	<p> 713 6503 30 713 6403 30 713 6504 20 713 6504 30 771 0060 30 771 0065 30 771 0036 30 771 0052 30 772 0254 30 772 0327 30 815 0058 30 815 0059 30 818 0226 10 825 0318 10 825 0319 10 840 0238 10 840 0285 10 840 0286 10 840 0926 10</p>
<p>2.8 JTD  8140.43S; (94kW)</p>	<p>03.01-04.02</p>	<p>LUK</p>	<p>Version: 230A /B/CP; →6144125; MG ; LHD Version: 230A /B/CP; →6144100; MG ; RHD Version: 230A /B/CP; 6144126→; MLGU ; LHD Version: 230A /B/CP; 6144101→; MLGU ; RHD</p>	<p> 624 3096 00 624 3165 00 530 0117 10 530 0601 10 531 0557 10 532 0239 20 531 0749 10 531 0812 10 532 0294 10 FB 5PK1100 FB 6PK948 FB 6PK995 538 0469 10 428 0080 10 821 0810 10 821 0859 10 821 0809 10 821 0858 10 713 6403 90 713 6404 00 713 6503 10 713 6503 30 713 6403 30 713 6504 20 713 6504 30 771 0060 30 771 0065 30 771 0036 30 772 0254 30 772 0327 30</p>
		<p>INA</p>	<p>OPTION</p> <p>A/C ; →3980846 A/C ; 3 398 847→ A/C A/C ; # OE 504171190 ; # OE 500385160</p>	<p> 531 0117 10 531 0557 10 532 0239 20 531 0749 10 531 0812 10 532 0294 10 FB 5PK1100 FB 6PK948 FB 6PK995 538 0469 10 428 0080 10 821 0810 10 821 0859 10 821 0809 10 821 0858 10 713 6403 90 713 6404 00 713 6503 10 713 6503 30 713 6403 30 713 6504 20 713 6504 30 771 0060 30 771 0065 30 771 0036 30 772 0254 30 772 0327 30</p>
		<p>FAG</p>	<p> right; 16 " right; 15 " left; 16 " left; 15 " ; 11.01→; 6194400→; 1.000 kg → 1.400 kg 84 mm ; 11.01→; 6194400→; 1.800kg 90 mm ; →11.01; →6194399; 1.000 kg → 1.400 kg 80 mm ; →11.01; →6194399; 1.800kg 89,92 mm ; 11.01→; 6194400→ 75 mm ; →11.01; →6194399; 1.000 kg → 1.400 kg ; →11.01; →6194399; 1.800kg ; → 1.400 kg 100 mm ; 1.800kg 122 mm ; MANU ; 1.000 kg → 1.400 kg 100 mm ; 1.000 kg → 1.400 kg; MANU ; 6194400→; 1.800kg; MANU ; 1.800kg; AUTOM</p>	<p> 713 6403 90 713 6404 00 713 6503 10 713 6503 30 713 6403 30 713 6504 20 713 6504 30 771 0060 30 771 0065 30 771 0036 30 772 0254 30 772 0327 30</p>



























			SCHAEFFLER
--	--	--	-------------------

FIAT

DUCATO (230)

2.8 JTD 8140.43S; (94kW)	03.01-04.02	FAG 	right;  →5616153		815 0058 30
			left;  5616154→		
			left;  →5616153		815 0059 30
			right;  5616154→		
					818 0226 10
			 ;  15 "		825 0318 10
			 ;  16 "		825 0319 10
					840 0238 10
			 ; 		840 0285 10
			 ; 		840 0286 10
					840 0926 10
2.8 JTD 4x4 8140.43S; (94kW)	10.01-04.02	LUK 	Version: 230A /B/CP;  →6144125;  MG ; LHD		624 3096 00
			Version: 230A /B/CP;  →6144100;  MG ; RHD		
			Version: 230A /B/CP;  6144126→;  MLGU ; LHD		624 3165 00
			Version: 230A /B/CP;  6144101→;  MLGU ; RHD		
			OPTION		530 0117 10
					530 0601 10
					531 0557 10
					532 0239 20
					533 0114 10
			A/C;  →3980846		531 0749 10
			A/C;  3 980 847→		531 0812 10
			A/C		532 0294 10
					538 0469 10
					428 0080 10
		FAG 	right;  16 "		821 0810 10
			right;  15 "		821 0859 10
			left;  16 "		821 0809 10
			left;  15 "		821 0858 10
			 →11.01;  1.000 kg →  1.400 kg		713 6503 10
			 80 mm		
			 75 mm		713 6403 30
			 84 mm		713 6403 90
			 90 mm		713 6404 00
			 89,92 mm		713 6503 30
					713 6504 20
					713 6504 30
			 →  1.400 kg		771 0060 30
			 100 mm		
			  MANU ;  1.000 kg →  1.400 kg		771 0036 30
			 100 mm		
			 →  1.000 kg →  1.400 kg;  MANU		772 0254 30
					772 0256 30
					818 0226 10
			 ;  15 "		825 0318 10
			 ;  16 "		825 0319 10
					840 0238 10
			 ; 		840 0285 10
			 ; 		840 0286 10
					840 0926 10

DUCATO (244)



































































































































2.0 JTD RHV (DW10); (62kW)	04.02-	LUK 			623 3043 00
					530 0111 10
					530 0111 30
					531 0264 10
					532 0196 10
			 ; A/C ; VET →7431901		531 0373 10
					532 0335 10
			 ; A/C ; VET →7431901; →05.04		534 0110 20
			 ; A/C ; VET →7431901		534 0111 20
			 ; A/C A/C ; VET 7431902→; 05.04→		
			 # F-229603.XX		535 0039 10
			 # F-232369.04/.05/.07 F-232369.08		535 0059 10
			 # F-236591.05/.07		535 0194 10
			→05.04; A/C		544 0039 10
			→05.04; A/C		544 0039 20
			 ; A/C		FB 4PK755



			SCHAEFFLER
--	---	--	-------------------

FIAT

DUCATO (244)





2.0 JTD RHV (DW10); (62kW)	04.02-		 A/C	 FB 6PK1180
			  A/C	 FB 6PK1468
			1x	 538 0008 10  428 0034 30
		FAG	 right;  16 "	 821 0810 10
			 right;  15 "	 821 0859 10
			 left;  16 "	 821 0809 10
			 left;  15 "	 821 0858 10
				 713 0400 20
			 ; →09.04;  1.100 kg →  1.500 kg  84 mm	 Set 713 6403 90
			 ; →05.04;  1.800kg  90 mm	 Set 713 6404 00
			 ; 09.04 →;  1.100 kg →  1.500 kg  84 mm	 Set 713 6909 30
			 ; 06.04 →;  1.800kg  90 mm	 Set 713 6909 40
				 Set 713 6403 30
			  → 1.400 kg  100 mm	 771 0060 30
			  1.800kg;  5235558 →  122 mm	 771 0065 30
			   1.000 kg →  1.400 kg  100 mm	 771 0036 30
			  1.800kg;  →5235557  115 mm	 771 0052 30
			  1.000 kg →  1.400 kg; 	 SET 772 0254 30
			 right	 814 0128 10
			 left	 814 0127 10
				 818 0226 10
			 ;  15 "	 825 0318 10
			 ;  16 "	 825 0319 10
			 840 0238 10	
		 ; 	 840 0285 10	
		 ; 	 840 0286 10	
			 840 0999 10	
			 623 3043 00	
2.0 JTD RHV (DW10); (62kW)	04.02-07.06			 530 0111 10
				 530 0111 30
				 531 0264 10
				 532 0196 10
				 531 0373 10
				 532 0335 10
				 534 0110 20
				 534 0111 20
				 535 0039 10
				 535 0059 10
				 535 0194 10
				 544 0039 10
				 544 0039 20
				 FB 4PK755
				 FB 6PK1180
				 FB 6PK1468
				 538 0008 10  428 0034 30
				 821 0810 10
				 821 0859 10
				 821 0809 10
	 821 0858 10			
	 713 0400 20			
	 Set 713 6403 90			
	 Set 713 6404 00			
	 Set 713 6909 30			
	 ; →09.04;  1.100 kg →  1.500 kg  84 mm	 Set 713 6403 90		
	 ; →05.04;  1.800kg  90 mm	 Set 713 6404 00		
	 ; 09.04 →;  1.100 kg →  1.500 kg 84 mm	 Set 713 6909 30		



			<p>SCHAEFFLER</p>
--	---	--	--------------------------

FIAT

DUCATO (244)





















































































































































































<p>2.0 JTD RHV (DW10); (62kW)</p>	<p>04.02-07.06</p>	<p>FAG</p>	<p> ; 06.04 → ; 1.800kg 90 mm 75 mm → ; → 1.400 kg 100 mm → ; 1.800kg; 5235558 → 122 mm → ; MANU ; 1.000 kg → 1.400 kg 100 mm → ; 1.800kg; →5235557 115 mm → ; 1.000 kg → 1.400 kg; MANU → ; →10.03; 1.800kg; MANU AUTOM right left ; 15" ; 16" ; ; </p>	<p> Set 713 6909 40 Set 713 6403 30 771 0060 30 771 0065 30 771 0036 30 771 0052 30 SET 772 0254 30 SET 772 0327 30 814 0128 10 814 0127 10 818 0226 10 825 0318 10 825 0319 10 840 0238 10 840 0285 10 840 0286 10 840 0999 10 </p>
<p>2.0 RFL (XU10J2U); (81kW)</p>	<p>04.02-</p>	<p>   <p>FAG</p> </p>	<p> A/C A/C 8x 38 mm right; 16" right; 15" left; 16" left; 15" →09.04; 1.100 kg → 1.500 kg 84 mm →05.04; 1.800kg 90 mm ; 09.04 → ; 1.100 kg → 1.500 kg 84 mm ; 06.04 → ; 1.800kg 90 mm 75 mm → ; → 1.400 kg 100 mm → ; 1.800kg; 5235558 → 122 mm → ; MANU ; 1.000 kg → 1.400 kg 100 mm → ; 1.800kg; →5235557 115 mm → ; 1.000 kg → 1.400 kg; MANU → ; 1.800kg right left ; 15" ; 16" ; ; </p>	<p> 624 3401 00 530 0233 10 530 0232 30 531 0047 10 531 0096 10 FB 6PK1090 538 0468 10 421 0010 10 821 0810 10 821 0859 10 821 0809 10 821 0858 10 713 0400 20 Set 713 6403 90 Set 713 6404 00 Set 713 6909 30 Set 713 6909 40 Set 713 6403 30 771 0060 30 771 0065 30 771 0036 30 771 0052 30 SET 772 0254 30 SET 772 0296 30 814 0128 10 814 0127 10 818 0226 10 825 0318 10 825 0319 10 840 0238 10 840 0285 10 840 0286 10 840 0999 10 </p>
<p>2.0 RFL (XU10J2U); (81kW)</p>	<p>04.02-07.06</p>	<p>   </p>	<p> </p>	<p> 624 3401 00 530 0233 10 531 0047 10 </p>



			SCHAEFFLER
--	---	--	-------------------

FIAT

DUCATO (244)

2.0 RFL (XU10J2U); (81kW)	04.02-07.06	 FAG	A/C		531 0096 10
			8x		538 0468 10
			 38 mm		421 0010 10
			 right;  16 "		821 0810 10
			 right;  15 "		821 0859 10
			 left;  16 "		821 0809 10
			 left;  15 "		821 0858 10
			 ; →09.04;  1.100 kg →  1.500 kg	 Set	713 6403 90
			 84 mm		713 6404 00
			 ; →05.04;  1.800kg		713 6404 00
			 90 mm		713 6404 00
			 ; 09.04 →;  1.100 kg →  1.500 kg		713 6909 30
			 84 mm		713 6909 30
			 ; 06.04 →;  1.800kg		713 6909 40
			 90 mm		713 6909 40
			 75 mm		713 6403 30
			 →  1.400 kg		771 0060 30
			 100 mm		771 0060 30
			 ;  MANU ;  1.000 kg →  1.400 kg		771 0036 30
			 100 mm		771 0036 30
 ;  1.000 kg →  1.400 kg;  MANU	 SET	772 0254 30			
 ; →10.03;  1.800kg;  MANU	 SET	772 0327 30			
 ; →10.03;  1.800kg;  AUTOM		772 0327 30			
 818 0226 10		818 0226 10			
 ;  15 "		825 0318 10			
 ;  16 "		825 0319 10			
 ; 		840 0285 10			
 ; 		840 0286 10			
 ; 		840 0286 10			
 ; 		840 0999 10			
2.0 4x4 RFL (XU10J2U); (81kW)	05.02-07.06	  FAG	→06.06		624 3401 00
					624 3401 00
			8x		530 0233 10
			 38 mm		531 0047 10
			 right;  16 "		421 0010 10
			 right;  15 "		821 0810 10
			 left;  16 "		821 0859 10
			 left;  15 "		821 0809 10
					821 0858 10
					713 0400 20
			 ; →09.04;  1.100 kg →  1.500 kg		713 6403 90
			 84 mm		713 6404 00
			 ; →05.04;  1.800kg		713 6404 00
			 90 mm		713 6404 00
			 ; 09.04 →;  1.100 kg →  1.500 kg		713 6909 30
			 84 mm		713 6909 30
			 ; 06.04 →;  1.800kg		713 6909 40
			 90 mm		713 6909 40
			 84 mm		713 6909 60
			 →  1.400 kg		771 0060 30
 100 mm		771 0060 30			
 ;  MANU ;  1.000 kg →  1.400 kg		771 0065 30			
 122 mm		771 0065 30			
 ;  MANU ;  1.000 kg →  1.400 kg		771 0036 30			
 100 mm		771 0036 30			
 ;  1.000 kg →  1.400 kg;  MANU		772 0254 30			
		772 0256 30			
 right		814 0128 10			
 left		814 0127 10			
 ↔		818 0226 10			
		818 0226 10			
 ;  15 "		825 0318 10			
 ;  16 "		825 0319 10			
 ; 		840 0285 10			
 ; 		840 0286 10			
 ↔		840 0999 10			



			<p>SCHAEFFLER</p>	
--	--	--	--------------------------	--

FIAT

DUCATO (244)





































































<p>2.0 4x4 RFL (XU10J2U); (81kW)</p>	<p>05.02-07.06</p>	<p>FAG</p>		<p>840 0999 10</p>	
<p>2.0 Bipower RFL (XU10J2U); (81kW)</p>	<p>11.02-</p>	<p>LUK</p>	<p>RFL RFL A/C; RFL A/C A/C</p>	<p>624 3401 00 530 0233 10 531 0047 10 531 0096 10 FB 4PK755 FB 6PK1090 FB 6PK1100</p>	
		<p>FAG</p>	<p>right; 16" right; 15" left; 16" left; 15" →09.04; 1.100 kg → 1.500 kg 84 mm →05.04; 1.800kg 90 mm 09.04 →; 1.100 kg → 1.500 kg 84 mm 06.04 →; 1.800kg 90 mm 75 mm →; 1.400 kg 100 mm →; 1.800kg; 5235558 → 122 mm →; MANU; 1.000 kg → 1.400 kg 100 mm →; 1.800kg; →5235557 115 mm →; 1.000 kg → 1.400 kg; MANU →; 1.800kg right left 15" 16" 840 0238 10 840 0285 10 840 0286 10</p>	<p>821 0810 10 821 0859 10 821 0809 10 821 0858 10 713 0400 20 Set 713 6403 90 Set 713 6404 00 Set 713 6909 30 Set 713 6909 40 Set 713 6403 30 771 0060 30 771 0065 30 771 0036 30 771 0052 30 SET 772 0254 30 SET 772 0296 30 814 0128 10 814 0127 10 818 0226 10 825 0318 10 825 0319 10 840 0238 10 840 0285 10 840 0286 10</p>	
<p>2.3 JTD F1AE0481C; (81kW)</p>	<p>04.02-</p>	<p>LUK</p>	<p>F-230846.XX 145 mm A/C; 0113089 → A/C; →0113089</p>	<p>624 3214 00 530 0232 10 530 0232 30 531 0505 10 532 0441 10 532 0298 10 533 0061 20 535 0022 10 544 0017 10 FB 4EPK903 FB 4PK985 FB 7PK1076</p>	
		<p>FAG</p>	<p>right; 16" right; 15" left; 16" left; 15" →09.04; 1.100 kg → 1.500 kg 84 mm →05.04; 1.800kg 90 mm</p>	<p>821 0810 10 821 0859 10 821 0809 10 821 0858 10 713 0400 20 Set 713 6403 90 Set 713 6404 00</p>	



			SCHAEFFLER
--	---	--	-------------------

FIAT

DUCATO (244)



































































































































































































2.3 JTD F1AE0481C; (81kW)	04.02-	FAG	09.04→; 1.100 kg → 1.500 kg  84 mm		713 6909 30			
			06.04→; 1.800kg  90 mm		713 6909 40			
			 75 mm		713 6403 30			
			→ 1.400 kg  100 mm		771 0060 30			
			1.800kg; 5235558→  122 mm		771 0065 30			
			→ 1.000 kg → 1.400 kg  100 mm		771 0036 30			
			1.800kg; →5235557  115 mm		771 0052 30			
			1.000 kg → 1.400 kg; MANU → 1.800kg		772 0254 30			
			right		814 0128 10			
			left		814 0127 10			
					818 0226 10			
			15"		825 0318 10			
			16"		825 0319 10			
					840 0238 10			
					840 0285 10			
					840 0286 10			
					840 0999 10			
			2.3 JTD F1AE0481C; (81kW)	04.02-07.06	LUK			624 3214 00
								530 0232 10
								530 0232 30
		531 0505 10						
		532 0441 10						
		532 0298 10						
		533 0061 20						
F-230846.XX		535 0022 10						
		544 0017 10						
		FB 4EPK903						
		FB 4PK985						
		FB 7PK1076						
		538 0130 10						
right; 16"		821 0810 10						
right; 15"		821 0859 10						
left; 16"		821 0809 10						
left; 15"		821 0858 10						
		713 0400 20						
→09.04; 1.100 kg → 1.500 kg  84 mm		713 6403 90						
→05.04; 1.800kg  90 mm		713 6404 00						
09.04→; 1.100 kg → 1.500 kg  84 mm		713 6909 30						
06.04→; 1.800kg  90 mm		713 6909 40						
75 mm		713 6403 30						
→ 1.400 kg 100 mm		771 0060 30						
1.800kg; 5235558→ 122 mm		771 0065 30						
→ 1.000 kg → 1.400 kg 100 mm		771 0036 30						
1.800kg; →5235557 115 mm		771 0052 30						
1.000 kg → 1.400 kg; MANU → 1.800kg		772 0254 30						
→ 10.03; 1.800kg; MANU AUTOM		772 0296 30						
right		814 0128 10						
left		814 0127 10						
		818 0226 10						
15"		825 0318 10						



			SCHAEFFLER
--	--	--	-------------------

FIAT

DUCATO (244)





















































































































































2.3 JTD F1AE0481C; (81kW)	04.02-07.06	FAG	 ;  16"	 825 0319 10  840 0238 10  840 0285 10  840 0286 10  840 0999 10
2.8 TD 8140.43; (90kW)	04.02-07.06	LUK 	OPTION	 530 0113 10  530 0603 10  532 0239 20  532 0239 20  533 0114 10  531 0749 10  428 0080 10
		FAG	 right;  16"  right;  15"  left;  16"  left;  15"   ; →09.04;  1.100 kg →  1.500 kg  84 mm  ; →05.04;  1.800kg  90 mm  ; 09.04 →;  1.100 kg →  1.500 kg  84 mm  ; 06.04 →;  1.800kg  90 mm   75 mm  ; →;  → 1.400 kg  100 mm  ;  MANU ;  1.000 kg →  1.400 kg  100 mm  ;  1.000 kg →  1.400 kg;  MANU  right  left   ;  15"  ;  16"  ;   ;   ;     ; →09.04;  1.100 kg →  1.500 kg  84 mm  ; →05.04;  1.800kg  90 mm  ; 09.04 →;  1.100 kg →  1.500 kg  84 mm  ; 06.04 →;  1.800kg  90 mm   75 mm  ; →;  → 1.400 kg  100 mm  ;  MANU ;  1.000 kg →  1.400 kg  100 mm  ;  1.000 kg →  1.400 kg;  MANU	 821 0810 10  821 0859 10  821 0809 10  821 0858 10  713 0400 20   713 6403 90   713 6404 00   713 6909 30   713 6909 40   713 6403 30   771 0060 30   771 0036 30   772 0254 30   814 0128 10   814 0127 10   818 0226 10   825 0318 10   825 0319 10   840 0285 10   840 0286 10   840 0999 10   624 3165 00
2.8 JTD 8140.43; (90kW)	11.03-07.06	LUK 	OPTION	 530 0113 10  530 0603 10  532 0239 20  532 0239 20  533 0114 10  531 0749 10  428 0080 10
		FAG	 right;  16"  right;  15"  left;  16"  left;  15"   ; →09.04;  1.100 kg →  1.500 kg  84 mm  ; →05.04;  1.800kg  90 mm  ; 09.04 →;  1.100 kg →  1.500 kg  84 mm  ; 06.04 →;  1.800kg  90 mm   75 mm  ; →;  → 1.400 kg  100 mm  ;  MANU ;  1.000 kg →  1.400 kg 100 mm ; 1.000 kg → 1.400 kg; MANU	 821 0810 10  821 0859 10  821 0809 10  821 0858 10  713 0400 20   713 6403 90   713 6404 00   713 6909 30   713 6909 40   713 6403 30   771 0060 30   771 0036 30   772 0254 30



			SCHAEFFLER
--	--	--	-------------------

FIAT

DUCATO (244)











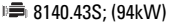

























































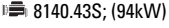



































































































2.8 JTD 8140.43; (90kW)	11.03-07.06	FAG	 right		814 0128 10	
			 left		814 0127 10	
			 ←		818 0226 10	
			 ;  15 "		825 0318 10	
			 ;  16 "		825 0319 10	
			 ; 		840 0285 10	
			 ; 		840 0286 10	
			 ←		840 0999 10	
					624 3165 00	
			2.8 TD 4x4 8140.43; (90kW)	11.03-07.06	LUK	
OPTION		530 0603 10				
		532 0239 20				
		532 0239 20				
		533 0114 10				
A/C		531 0749 10				
		428 0080 10				
FAG	 right;  16 "					821 0810 10
 right;  15 "		821 0859 10				
 left;  16 "		821 0809 10				
 left;  15 "		821 0858 10				
		713 0400 20				
 ; →09.04;  1.100 kg →  1.500 kg  84 mm	 Set	713 6403 90				
 ; →05.04;  1.800kg  90 mm	 Set	713 6404 00				
 ; 09.04 →;  1.100 kg →  1.500 kg  84 mm	 Set	713 6909 30				
 ; 06.04 →;  1.800kg  90 mm	 Set	713 6909 40				
 84 mm	 Set	713 6909 60				
 =  ;  → 1.400 kg  100 mm		771 0060 30				
 =  ;  MANU ;  1.000 kg →  1.400 kg  100 mm		771 0036 30				
 =  ;  1.000 kg →  1.400 kg;  MANU  = 	 SET  SET	772 0254 30 772 0256 30				
 right		814 0128 10				
 left		814 0127 10				
		818 0226 10				
 ;  15 "		825 0318 10				
 ;  16 "		825 0319 10				
 ; 		840 0285 10				
 ; 		840 0286 10				
 ←		840 0999 10				
		624 3165 00				
2.8 JTD 8140.43S; (94kW)	04.02-	LUK			530 0117 10	
			OPTION		530 0601 10	
					531 0557 10	
					532 0239 20	
					533 0114 10	
			A/C ;  → 3 980 846		531 0749 10	
			A/C ;  3 398 847 →		531 0812 10	
			A/C		532 0294 10	
			A/C		FB 5PK1100	
			 ;  MANU		FB 6PK948	
 ;  AUTOM		FB 6PK995				
		538 0469 10				
		428 0080 10				
FAG	 right;  16 "		821 0810 10			
 right;  15 "		821 0859 10				
 left;  16 "		821 0809 10				
 left;  15 "		821 0858 10				
		713 0400 20				
 ; →09.04;  1.100 kg →  1.500 kg  84 mm	 Set	713 6403 90				
 ; →05.04;  1.800kg  90 mm	 Set	713 6404 00				



			SCHAEFFLER
--	---	--	-------------------

FIAT

DUCATO (244)



















































































































































<p>2.8 JTD  8140.43S; (94kW)</p>	<p>04.02-</p>	<p>FAG</p> <ul style="list-style-type: none">  ; 09.04 →;  1.100 kg →  1.500 kg  84 mm  ; 06.04 →;  1.800kg  90 mm  75 mm  ;  → 1.400 kg  100 mm  ;  1.800kg;  5235558 →  122 mm  ;  MANU ;  1.000 kg →  1.400 kg  100 mm  ;  1.800kg;  → 5235557  115 mm  ;  1.000 kg →  1.400 kg;  MANU  ;  1.800kg  right  left  15 "  16 "  840 0238 10  840 0285 10  840 0286 10  840 0999 10 	<ul style="list-style-type: none">  Set 713 6909 30  Set 713 6909 40  Set 713 6403 30  771 0060 30  771 0065 30  771 0036 30  771 0052 30  SET 772 0254 30  SET 772 0296 30  814 0128 10  814 0127 10  818 0226 10  825 0318 10  825 0319 10  840 0238 10  840 0285 10  840 0286 10  840 0999 10  624 3165 00
<p>2.8 JTD  8140.43S; (94kW)</p>	<p>04.02-07.06</p>	<p>LUK</p> <p></p> <p>OPTION</p> <ul style="list-style-type: none">  530 0117 10  530 0601 10  531 0557 10  532 0239 20  533 0114 10  531 0749 10  531 0812 10  532 0294 10  FB 5PK1100  FB 6PK948  FB 6PK995  538 0469 10  428 0080 10  821 0810 10  821 0859 10  821 0809 10  821 0858 10  713 0400 20  Set 713 6403 90  Set 713 6404 00  Set 713 6909 30  Set 713 6909 40  Set 713 6403 30  771 0060 30  771 0065 30  771 0036 30  771 0052 30  SET 772 0254 30  SET 772 0296 30  SET 772 0327 30  814 0128 10  814 0127 10 818 0226 10 825 0318 10 <p>FAG</p> <ul style="list-style-type: none">  right;  16 "  right;  15 "  left;  16 "  left;  15 "  ; → 09.04;  1.100 kg →  1.500 kg  84 mm  ; → 05.04;  1.800kg  90 mm  ; 09.04 →;  1.100 kg →  1.500 kg  84 mm  ; 06.04 →;  1.800kg  90 mm  75 mm  ;  → 1.400 kg  100 mm  ;  1.800kg;  5235558 →  122 mm  ;  MANU ;  1.000 kg →  1.400 kg  100 mm  ;  1.800kg;  → 5235557  115 mm  ;  1.000 kg →  1.400 kg;  MANU  ;  1.800kg ; → 10.03; 1.800kg; MANU AUTOM right left 15 " 	<ul style="list-style-type: none">  530 0117 10  530 0601 10  531 0557 10  532 0239 20  533 0114 10  531 0749 10  531 0812 10  532 0294 10  FB 5PK1100  FB 6PK948  FB 6PK995  538 0469 10  428 0080 10  821 0810 10  821 0859 10  821 0809 10  821 0858 10  713 0400 20  Set 713 6403 90  Set 713 6404 00  Set 713 6909 30  Set 713 6909 40  Set 713 6403 30  771 0060 30  771 0065 30  771 0036 30  771 0052 30  SET 772 0254 30  SET 772 0296 30  SET 772 0327 30  814 0128 10  814 0127 10 818 0226 10 825 0318 10



			SCHAEFFLER
--	---	--	-------------------

FIAT

DUCATO (244)

<p>2.8 JTD  8140.43S; (94kW)</p>	<p>04.02-07.06</p>	<p>FAG</p>	<p>;  16 "</p> <p>; </p> <p>; </p> <p></p>	<p> 825 0319 10</p> <p> 840 0238 10</p> <p> 840 0285 10</p> <p> 840 0286 10</p> <p> 840 0999 10</p>	
<p>2.8 JTD 4x4  8140.43S; (94kW)</p>	<p>07.02-</p>	<p>LUK</p>	<p>OPTION</p>	<p> 530 0117 10</p> <p> 530 0601 10</p>	
		<p></p>	<p> 531 0557 10</p> <p> 532 0239 20</p> <p> 533 0114 10</p> <p> 531 0749 10</p> <p> 531 0812 10</p> <p> 532 0294 10</p> <p> FB 5PK1100</p> <p> FB 6PK948</p> <p> FB 6PK995</p>	<p> 538 0469 10</p> <p> 428 0080 10</p>	
		<p>FAG</p>	<p> right;  16 "</p> <p> right;  15 "</p> <p> left;  16 "</p> <p> left;  15 "</p> <p></p> <p>; →09.04;  1.100 kg →  1.500 kg</p> <p> 84 mm</p> <p>; →05.04;  1.800kg</p> <p> 90 mm</p> <p>; 09.04 →;  1.100 kg →  1.500 kg</p> <p> 84 mm</p> <p>; 06.04 →;  1.800kg</p> <p> 90 mm</p> <p></p> <p> 84 mm</p> <p>;  → 1.400 kg</p> <p> 100 mm</p> <p>;  1.800kg;  5235558 →</p> <p> 122 mm</p> <p>; ;  MANU;  1.000 kg →  1.400 kg</p> <p> 100 mm</p> <p>;  1.800kg;  →5235557</p> <p> 115 mm</p> <p>;  1.000 kg →  1.400 kg;  MANU</p> <p></p> <p>;  1.800kg</p> <p> right</p> <p> left</p> <p></p> <p>;  15 "</p> <p>;  16 "</p> <p></p> <p>; </p> <p>; </p> <p></p> <p></p>	<p> 821 0810 10</p> <p> 821 0859 10</p> <p> 821 0809 10</p> <p> 821 0858 10</p> <p> 713 0400 20</p> <p>  713 6403 90</p> <p>  713 6404 00</p> <p>  713 6909 30</p> <p>  713 6909 40</p> <p>  713 6909 60</p> <p> 771 0060 30</p> <p> 771 0065 30</p> <p> 771 0036 30</p> <p> 771 0052 30</p> <p>  772 0254 30</p> <p>  772 0256 30</p> <p>  772 0296 30</p> <p> 814 0128 10</p> <p> 814 0127 10</p> <p> 818 0226 10</p> <p> 825 0318 10</p> <p> 825 0319 10</p> <p> 840 0238 10</p> <p> 840 0285 10</p> <p> 840 0286 10</p> <p> 840 0999 10</p> <p> 624 3165 00</p>	
<p>2.8 JTD  8140.43N; (107kW)</p>	<p>04.04-07.06</p>	<p>LUK</p>	<p>OPTION</p>	<p> 530 0117 10</p> <p> 530 0601 10</p>	
		<p></p>	<p> 531 0557 10</p> <p> 532 0239 20</p> <p> 533 0114 10</p> <p> 531 0749 10</p> <p> 532 0294 10</p> <p> FB 5PK1100</p> <p> FB 6PK948</p> <p> FB 6PK995</p>	<p> 538 0469 10</p> <p> 428 0080 10</p>	
		<p>FAG</p>	<p> right;  16 "</p> <p> right;  15 "</p>	<p> 821 0810 10</p> <p> 821 0859 10</p>	



			<p>SCHAEFFLER</p>	
--	--	--	--------------------------	--

FIAT

DUCATO (244)

<p>2.8 JTD 8140.43N; (107kW)</p>	<p>04.04-07.06</p>	<p>FAG</p>	<p>left; 16" left; 15" →09.04; 1.100 kg → 1.500 kg 84 mm →05.04; 1.800kg 90 mm 09.04→; 1.100 kg → 1.500 kg 84 mm 06.04→; 1.800kg 90 mm 75 mm → 1.400 kg 100 mm MANU; 1.000 kg → 1.400 kg 100 mm 1.000 kg → 1.400 kg; MANU right left 15" 16" 840 0285 10 840 0286 10 840 0999 10</p>	<p>821 0809 10 821 0858 10 713 0400 20 Set 713 6403 90 Set 713 6404 00 Set 713 6909 30 Set 713 6909 40 Set 713 6403 30 771 0060 30 771 0036 30 SET 772 0254 30 814 0128 10 814 0127 10 818 0226 10 825 0318 10 825 0319 10 840 0285 10 840 0286 10 840 0999 10</p>	
<p>2.8 JTD Power 8140.43N; (107kW)</p>	<p>05.04-</p>	<p>LUK INA FAG</p>	<p>OPTION 530 0117 10 530 0601 10 531 0557 10 532 0239 20 533 0114 10 531 0749 10 A/C 532 0294 10 A/C FB 5PK1100 FB 6PK948 AUTOM FB 6PK995 538 0469 10 428 0080 10 right; 16" right; 15" left; 16" left; 15" →09.04; 1.100 kg → 1.500 kg 84 mm →05.04; 1.800kg 90 mm 09.04→; 1.100 kg → 1.500 kg 84 mm 06.04→; 1.800kg 90 mm 75 mm → 1.400 kg 100 mm MANU; 1.000 kg → 1.400 kg 100 mm 1.000 kg → 1.400 kg; MANU right left 15" 16" 840 0238 10 840 0285 10 840 0286 10 840 0999 10</p>	<p>624 3165 00 530 0117 10 530 0601 10 531 0557 10 532 0239 20 533 0114 10 531 0749 10 532 0294 10 FB 5PK1100 FB 6PK948 FB 6PK995 538 0469 10 428 0080 10 821 0810 10 821 0859 10 821 0809 10 821 0858 10 713 0400 20 Set 713 6403 90 Set 713 6404 00 Set 713 6909 30 Set 713 6909 40 Set 713 6403 30 771 0060 30 771 0036 30 SET 772 0254 30 814 0128 10 814 0127 10 818 0226 10 825 0318 10 825 0319 10 840 0238 10 840 0285 10 840 0286 10 840 0999 10</p>	

































































































			SCHAEFFLER
--	---	--	-------------------

FIAT

DUCATO (244)

2.8 JTD Power
 8140.43N; (107kW)













































05.04-07.06

			624 3165 00
			530 0117 10
	OPTION		530 0601 10
			531 0557 10
			532 0239 20
			533 0114 10
	 ;  8140.43N		531 0749 10
	A/C ;  8140.43N		532 0294 10
	A/C		FB 5PK1100
	 ;  MANU		FB 6PK948
	 ;  AUTOM		FB 6PK995
			538 0469 10
			428 0080 10
FAG	 right;  16"		821 0810 10
	 right;  15"		821 0859 10
	 left;  16"		821 0809 10
	 left;  15"		821 0858 10
			713 0400 20
	 ; →09.04;  1.100 kg →  1.500 kg		713 6403 90
	 84 mm		
	 ; →05.04;  1.800kg		713 6404 00
	 90 mm		
	 ; 09.04 →;  1.100 kg →  1.500 kg		713 6909 30
	 84 mm		
	 ; 06.04 →;  1.800kg		713 6909 40
	 90 mm		
			713 6403 30
	 75 mm		
	 ;  → 1.400 kg		771 0060 30
	 100 mm		
	 ;  MANU;  1.000 kg →  1.400 kg		771 0036 30
	 100 mm		
	 ;  1.000 kg →  1.400 kg;  MANU		772 0254 30
	 right		814 0128 10
	 left		814 0127 10
			818 0226 10
	 ;  15"		825 0318 10
	 ;  16"		825 0319 10
			840 0238 10
	 ; 		840 0285 10
	 ; 		840 0286 10
			840 0999 10

DUCATO (250)

115 Multijet 2,0 D
 250 A1.000; 250 A2.000; (85kW)

06.11-































































































	SAC		624 3751 09
			415 0663 10
			411 0122 10
			530 0562 10
			530 0562 30
			531 0844 10
			532 0611 10
	 ; A/C		532 0505 10
			532 0617 10
			534 0610 10
	 # F-238822.XX		535 0112 10
	 # F-565229.XX F-568861.XX		535 0181 10
	 ; A/C		FB 6PK1370
	 ; A/C		FB 6PK1705
			538 0714 10
	16x		420 0181 10
	 12 mm		
	16x		422 0075 10
FAG	 right		821 0628 10
	 left		821 0627 10
			713 6405 50
	 90 mm		
	 ;  1.600 2.000kg; 		713 6405 60
	 ;  1.200 1.400 1.600kg; 		713 6405 70
			771 0552 30



			<p>SCHAEFFLER</p>
--	--	--	--------------------------

FIAT

DUCATO (250)



























































































































<p>115 Multijet 2,0 D 250 A1.000; 250 A2.000; (85kW)</p>	<p>06.11-</p>	<p>FAG</p>	<p> 814 0157 10  814 0158 10  818 0012 10  818 0479 10  818 0473 10  818 0480 10  825 0277 10  840 0388 10  right 840 1050 10  left 840 1055 10</p>	<p>814 0157 10 814 0158 10 818 0012 10 818 0479 10 818 0473 10 818 0480 10 825 0277 10 840 0388 10 840 1050 10 840 1055 10</p>
<p>100 Multijet 2,2 D 4HV (P22DTE); (74kW)</p>	<p>07.06-</p>	<p>LUK</p> <p></p>	<p>SAC  →05.11;  BM Ducato 30; A/C  →05.11;  BM Ducato 33; A/C  →05.11;  BM Ducato 35; + ACC  →05.11;  BM Ducato 40; A/C  →05.11;  BM Ducato 30; A/C  →05.11;  BM Ducato 33; A/C  →05.11;  BM Ducato 35; A/C  →05.11;  BM Ducato 40; A/C  ; A/C  ; A/C        # F-554766.XX  ; A/C  ; A/C 1x  558 0063 10 1x  558 0066 10 1x  559 0193 10 1x  559 0193 30  right 821 0628 10  left 821 0627 10   713 6405 50  90 mm  ;  1.600 2.000kg;   ;  1.200 1.400 1.600kg;   ;            ; OPTION      right 840 1050 10  left 840 1055 10</p>	<p>624 3303 00 529 0301 10 529 0301 10 529 0383 10 529 0301 30 532 0470 10 532 0477 10 534 0308 10 535 0160 10 FB 4EPK922 FB 6EPK873 FB 6PK1670 538 0465 10 558 0063 10 558 0066 10 559 0193 10 559 0193 30 821 0628 10 821 0627 10 713 6405 50 713 6405 60 713 6405 70 771 0573 30 814 0157 10 814 0158 10 818 0012 10 818 0479 10 818 0473 10 818 0480 10 825 0277 10 840 0388 10 840 1050 10 840 1055 10 624 3303 00 529 0301 10 529 0383 10 529 0301 30 532 0470 10 532 0477 10 534 0308 10 535 0160 10 FB 4EPK922 FB 6EPK873 FB 6PK1670 538 0465 10 558 0063 10 558 0066 10 559 0193 10</p>
<p>100 Multijet 2,2 D 4HV (P22DTE); (74kW)</p>	<p>07.06-05.11</p>	<p>LUK</p> <p></p>	<p>SAC  ;  BM Ducato 30; A/C  ; 10.06 →;  BM Ducato 35; A/C  ;  BM Ducato 33; A/C  ;  BM Ducato 40; A/C  ; A/C  ; A/C        # F-554766.XX  ; A/C  ; A/C 1x  558 0063 10 1x  558 0066 10 1x  559 0193 10</p>	<p>624 3303 00 529 0301 10 529 0383 10 529 0301 30 532 0470 10 532 0477 10 534 0308 10 535 0160 10 FB 4EPK922 FB 6EPK873 FB 6PK1670 538 0465 10 558 0063 10 558 0066 10 559 0193 10</p>



			SCHAEFFLER
--	--	--	-------------------

FIAT

DUCATO (250)

100 Multijet 2,2 D 4HV (P22DTE); (74kW)	07.06-05.11	 FAG	1x		559 0193 30
			 right		821 0628 10
			 left		821 0627 10
					713 6405 50
			 90 mm		713 6405 60
			 ;  1.600 2.000kg;  \bar{I}		713 6405 70
			 ;  1.200 1.400 1.600kg;  \bar{Z}		771 0573 30
			 ; 		814 0157 10
					814 0158 10
					818 0012 10
					818 0479 10
					818 0473 10
			 \leftrightarrow ;  \rightarrow ; OPTION		818 0480 10
					825 0277 10
					840 0388 10
		840 1050 10			
		840 1055 10			
110 Multijet 2,3 D 130 Multijet 2,3 D 4x4 F1AE0481N; F1AE3481D; F1AE3481G; F1AGL411D; F1AGL411M; (82-96kW)	08.06-				530 0232 10
					530 0232 30
					531 0505 10
					532 0441 10
			 ; A/C		529 0383 10
					538 0130 10
					530 0232 30
110 Multijet 2,3 D F1AE3481G; (82kW)	05.14-				530 0232 30
					531 0505 10
					532 0441 10
			 ; A/C		529 0383 10
			EURO 6		535 0235 10
			 # F-560671.XX		538 0130 10
					530 0232 30
110 Multijet 2,3 D F1AE3481G; (83kW)	10.11-				530 0232 30
					531 0505 10
					532 0441 10
			 ; A/C		529 0383 10
					532 0298 10
					533 0061 20
			 # F-230846.XX		535 0022 10
			 145 mm		544 0017 10
			A/C		FB 4EPK903
					FB 7PK1076
					538 0130 10
			 right		821 0628 10
			 left		821 0627 10
					713 6405 50
			 90 mm		713 6405 60
 ;  1.600 2.000kg;  \bar{I}		713 6405 70			
 ;  1.200 1.400 1.600kg;  \bar{Z}		814 0157 10			
		814 0158 10			
		818 0012 10			
		818 0479 10			
		818 0473 10			
 \leftrightarrow ;  \rightarrow ; OPTION		818 0480 10			
		825 0277 10			
		840 0388 10			
		840 1050 10			
		840 1055 10			
120 Multijet 2,3 D F1AE0481D; (88kW)	07.06-		09.08 \rightarrow ;  MANU SAC		625 3145 33
			\rightarrow 09.08;  MANU SAC		625 3165 09
			 SEMI ;  Selespeed SAC		626 3033 09
			 Selespeed SAC		626 3033 33



































			SCHAEFFLER
--	--	--	-------------------

FIAT

DUCATO (250)

































120 Multijet 2,3 D
 F1AE0481D; (88kW)

07.06-

		Selespeed		415 0673 10	
		SEMI ; Selespeed ;		411 0253 10	
				530 0232 10	
				530 0232 30	
				531 0505 10	
				532 0441 10	
		A/C		529 0383 10	
				532 0298 10	
				533 0061 20	
		# F-230846.XX		535 0022 10	
		A/C		544 0017 10	
		145 mm			
		A/C		FB 4EPK903	
				FB 7PK1076	
				538 0130 10	
			right		821 0628 10
			left		821 0627 10
					713 6405 50
			90 mm		
			1.600 2.000kg; I		713 6405 60
			1.200 1.400 1.600kg; X		713 6405 70
					771 0573 30
				814 0157 10	
				814 0158 10	
				818 0012 10	
				818 0479 10	
				818 0473 10	
		<->; OPTION		818 0480 10	
				825 0277 10	
				840 0388 10	
		right		840 1050 10	
		left		840 1055 10	

120 Multijet 2,3 D
 F1AE0481D; F1AGL4114; (88kW)

07.06-

































































































		09.08->; MANU SAC		625 3145 33	
		->09.08; MANU SAC		625 3165 09	
		SEMI ; Selespeed SAC		626 3033 09	
		Selespeed SAC		626 3033 33	
		Selespeed		415 0673 10	
		SEMI ; Selespeed ;		411 0170 11	
		SEMI ; Selespeed ;		411 0253 10	
				530 0232 10	
				530 0232 30	
				531 0505 10	
				532 0441 10	
			A/C		529 0383 10
				532 0298 10	
				533 0061 20	
		# F-230846.XX		535 0022 10	
		A/C		544 0017 10	
		145 mm			
		A/C		FB 4EPK903	
				FB 7PK1076	
				538 0130 10	
			right		821 0628 10
			left		821 0627 10
				713 6405 50	
		90 mm			
		1.600 2.000kg; I		713 6405 60	
		1.200 1.400 1.600kg; X		713 6405 70	
				771 0573 30	
				814 0157 10	
				814 0158 10	
				818 0012 10	
				818 0479 10	
				818 0473 10	



			SCHAEFFLER
--	---	--	-------------------

FIAT

DUCATO (250)

<p>120 Multijet 2,3 D F1AE0481D; F1AGL4114; (88kW)</p>	<p>07.06-</p>	<p>FAG</p>	<p> ↔;  ↗; OPTION</p> <p> ↔</p> <p> ↔</p> <p> right</p> <p> left</p>	<p> 818 0480 10</p> <p> 825 0277 10</p> <p> 840 0388 10</p> <p> 840 1050 10</p> <p> 840 1055 10</p>	
<p>120 Multijet 2,3 D F1AE0481D; F1AGL4114; FPT; (88kW)</p>	<p>07.06-</p>	<p>LUK</p>	<p>09.08 →;  MANU SAC</p> <p>→09.08;  MANU SAC</p> <p> Selespeed SAC</p> <p> SEMI;  Selespeed SAC</p> <p> Selespeed</p> <p> SEMI;  Selespeed; </p> <p> SEMI;  Selespeed; </p>	<p> 625 3145 33</p> <p> 625 3165 09</p> <p> 626 3033 09</p> <p> 626 3033 33</p> <p> 415 0673 10</p> <p> 411 0170 11</p> <p> 411 0253 10</p>	
		<p></p>	<p></p> <p> A/C</p> <p></p> <p></p> <p> F-230846.XX</p> <p> A/C</p> <p> 145 mm</p> <p>A/C</p> <p></p> <p></p> <p></p> <p></p> <p></p> <p></p> <p></p> <p></p> <p></p>	<p> 530 0232 10</p> <p> 530 0232 30</p> <p> 531 0505 10</p> <p> 532 0441 10</p> <p> 529 0383 10</p> <p> 532 0298 10</p> <p> 533 0061 20</p> <p> 535 0022 10</p> <p> 544 0017 10</p> <p> FB 4EPK903</p> <p> FB 7PK1076</p> <p> 538 0130 10</p>	
	<p>03.10-</p>	<p>FAG</p>	<p> right</p> <p> left</p> <p> 90 mm</p> <p> ;  1.600 2.000kg;  I</p> <p> ;  1.200 1.400 1.600kg;  Z</p> <p> ;  </p> <p> </p> <p> </p> <p> </p> <p> ↔</p> <p> ↔</p> <p> ↔;  ↗; OPTION</p> <p> ↔</p> <p> ↔</p> <p> ↔</p> <p> right</p> <p> left</p> <p> 90 mm</p> <p> ; 1.600 2.000kg; I</p>	<p> 821 0628 10</p> <p> 821 0627 10</p> <p> Set 713 6405 50</p> <p> Set 713 6405 60</p> <p> Set 713 6405 70</p> <p> 771 0573 30</p> <p> 814 0157 10</p> <p> 814 0158 10</p> <p> 818 0012 10</p> <p> 818 0479 10</p> <p> 818 0473 10</p> <p> 818 0480 10</p> <p> 825 0277 10</p> <p> 840 0388 10</p> <p> 840 1050 10</p> <p> 840 1055 10</p> <p> 625 3145 33</p> <p> 626 3033 33</p> <p> 415 0673 10</p> <p> 411 0170 11</p> <p> 411 0253 10</p> <p> 530 0232 10</p> <p> 530 0232 30</p> <p> 531 0505 10</p> <p> 532 0441 10</p> <p> 529 0383 10</p> <p> 532 0298 10</p> <p> 533 0061 20</p> <p> 535 0022 10</p> <p> 544 0017 10</p> <p> 538 0130 10</p> <p> 821 0628 10</p> <p> 821 0627 10</p> <p> Set 713 6405 50</p> <p> Set 713 6405 60</p>	



			<p>SCHAEFFLER</p>
--	--	--	--------------------------

FIAT

























































































































DUCATO (250)

<p>120 Multijet 2,3 D 4x4 F1AE0481D; (88kW)</p>	<p>03.10-</p>	<p>FAG</p> <p> ; 1.200 1.400 1.600kg; </p> <p> </p> <p> </p> <p></p> <p> ↔</p> <p> ↔</p> <p> ↔; ; OPTION</p> <p> ↔</p> <p> ↔</p> <p> right</p> <p> left</p>	<p> Set 713 6405 70</p> <p> 814 0157 10</p> <p> 814 0158 10</p> <p> 818 0012 10</p> <p> 818 0479 10</p> <p> 818 0473 10</p> <p> 818 0480 10</p> <p> 825 0277 10</p> <p> 840 0388 10</p> <p> 840 1050 10</p> <p> 840 1055 10</p>
<p>130 Multijet 2,3 D F1AE0481T; (93kW)</p>	<p>08.06-</p>	<p>LUK</p> <p> 1521298→; MANU</p> <p> 1502430→; MANU</p> <p>SAC</p> <p> →1521297; MANU</p> <p> →1502429; MANU</p> <p>SAC</p> <p> SEMI ; Selespeed</p> <p>SAC</p> <p> Selespeed</p> <p> SEMI ; Selespeed ; </p> <p> SEMI ; Selespeed ; </p> <p>INA</p> <p></p> <p></p> <p></p> <p></p> <p> ; A/C</p> <p></p> <p></p> <p></p> <p># F-230846.XX</p> <p>145 mm</p> <p>FAG</p> <p> right</p> <p> left</p> <p></p> <p>90 mm</p> <p> ; 1.600 2.000kg; </p> <p> ; 1.200 1.400 1.600kg; </p> <p> </p> <p> </p> <p></p> <p> ↔</p> <p> ↔</p> <p> ↔; ; OPTION</p> <p> ↔</p> <p> ↔</p> <p> right</p> <p> left</p>	<p> 625 3145 33</p> <p> 625 3165 09</p> <p> 626 3033 33</p> <p> 415 0673 10</p> <p> 411 0170 11</p> <p> 411 0253 10</p> <p> 530 0232 10</p> <p> 530 0232 30</p> <p> 531 0505 10</p> <p> 532 0441 10</p> <p> 529 0383 10</p> <p> 532 0298 10</p> <p> 533 0061 20</p> <p> 535 0022 10</p> <p> 544 0017 10</p> <p> 538 0130 10</p> <p> 821 0628 10</p> <p> 821 0627 10</p> <p> Set 713 6405 50</p> <p> Set 713 6405 60</p> <p> Set 713 6405 70</p> <p> 814 0157 10</p> <p> 814 0158 10</p> <p> 818 0012 10</p> <p> 818 0479 10</p> <p> 818 0473 10</p> <p> 818 0480 10</p> <p> 825 0277 10</p> <p> 840 0388 10</p> <p> 840 1050 10</p> <p> 840 1055 10</p>
<p>130 Multijet 2,3 D F1AE0481N; F1AE3481D; F1AGL411D; (96kW)</p>	<p>07.06-</p>	<p>LUK</p> <p> 1521298→; MANU</p> <p> 1502430→; MANU</p> <p>SAC</p> <p> →1521297; MANU</p> <p> →1502429; MANU</p> <p>SAC</p> <p> SEMI ; Selespeed</p> <p>SAC</p> <p> Selespeed</p> <p> SEMI ; Selespeed ; </p> <p> SEMI ; Selespeed ; </p> <p>INA</p> <p></p> <p></p> <p></p> <p></p> <p> ; A/C</p> <p></p> <p></p> <p></p> <p># F-230846.XX</p>	<p> 625 3145 33</p> <p> 625 3165 09</p> <p> 626 3033 33</p> <p> 415 0673 10</p> <p> 411 0170 11</p> <p> 411 0253 10</p> <p> 530 0232 10</p> <p> 530 0232 30</p> <p> 531 0505 10</p> <p> 532 0441 10</p> <p> 529 0383 10</p> <p> 532 0298 10</p> <p> 533 0061 20</p> <p> 535 0022 10</p>



			SCHAEFFLER
--	--	--	-------------------

FIAT

DUCATO (250)										
130 Multijet 2,3 D F1AE0481N; F1AE3481D; F1AGL411D; (96kW)	07.06-		 A/C  145 mm A/C 	 544 0017 10  FB 4EPK903  FB 7PK1076  538 0130 10						
			FAG  right  left  90 mm  ;  1.600 2.000kg;   ;  1.200 1.400 1.600kg;        ↔  ↔  ↔;  ; OPTION  ↔  ↔  right  left	 821 0628 10  821 0627 10   713 6405 50   713 6405 60   713 6405 70  814 0157 10  814 0158 10  818 0012 10  818 0479 10  818 0473 10  818 0480 10  825 0277 10  840 0388 10  840 1050 10  840 1055 10						
			130 Multijet 2,3 D F1AE0481N; F1AE3481D; F1AGL411D; F1AGL411M; (96kW)	06.11-		 1521298 →;  MANU  1502430 →;  MANU SAC  →1521297;  MANU  →1502429;  MANU SAC  SEMI ;  Selespeed SAC  SEMI ;  Selespeed SAC  Selespeed  SEMI ;  Selespeed ;   SEMI ;  Selespeed ; 	 625 3145 09  625 3145 33  626 3033 09  626 3033 33  415 0673 10  411 0170 11  411 0253 10			
						 ; A/C   # F-230846.XX  145 mm A/C 	 530 0232 10  530 0232 30  531 0505 10  532 0441 10  529 0383 10  532 0298 10  533 0061 20  535 0022 10  544 0017 10  FB 4EPK903  FB 7PK1076  538 0130 10  821 0628 10  821 0627 10   713 6405 50   713 6405 60   713 6405 70  814 0157 10  814 0158 10  818 0012 10  818 0479 10  818 0473 10  818 0480 10  825 0277 10  840 0388 10  840 1050 10  840 1055 10			
						130 Multijet 2,3 D F1AE0481N; F1AE3481D; F1AGL411D; (96kW)	06.11-		 1521298 →;  MANU  1502430 →;  MANU SAC  →1521297;  MANU  →1502429;  MANU SAC	 625 3145 33  625 3165 09











































































			<p>SCHAEFFLER</p>
--	--	--	--------------------------

FIAT

DUCATO (250)



























































130 Multijet 2,3 D
 F1AE0481N; F1AE3481D;
 F1AGL411D; (96kW)

06.11-

		 SEMI ;  Selespeed SAC		626 3033 09
	 Selespeed SAC		626 3033 33	
	 Selespeed		415 0673 10	
	 SEMI ;  Selespeed ; 		411 0170 11	
	 SEMI ;  Selespeed ; 		411 0253 10	
			530 0232 10	
			530 0232 30	
			531 0505 10	
			532 0441 10	
	 ; A/C		529 0383 10	
			532 0298 10	
			533 0061 20	
	 # F-230846.XX		535 0022 10	
	 A/C		544 0017 10	
	 145 mm			
	A/C		FB 4EPK903	
			FB 7PK1076	
			538 0130 10	
	FAG	 right		821 0628 10
		 left		821 0627 10
			713 6405 50	
 90 mm			713 6405 60	
 ;  1.600 2.000kg; 			713 6405 70	
 ;  1.200 1.400 1.600kg; 				
			814 0157 10	
			814 0158 10	
			818 0012 10	
 ↔			818 0479 10	
 ↔			818 0473 10	
 ↔;  ; OPTION			818 0480 10	
 ↔			825 0277 10	
 ↔			840 0388 10	
 right			840 1050 10	
 left			840 1055 10	

150 Multijet 2,3 D
 F1AE3481E; (109kW)











































































































06.11-

		 MANU SAC		625 3145 33
		SAC		625 3145 33
		 Selespeed SAC		626 3033 33
		 Selespeed		415 0673 10
		 Selespeed		411 0170 11
				530 0232 10
				530 0232 30
				531 0505 10
				532 0441 10
		 ; A/C		529 0383 10
			532 0298 10	
			533 0061 20	
	 # F-230846.XX		535 0022 10	
	 A/C		544 0017 10	
	 145 mm			
	A/C		FB 4EPK903	
			FB 7PK1076	
			538 0130 10	
	FAG	 right		821 0628 10
		 left		821 0627 10
			713 6405 50	
 90 mm			713 6405 60	
 ;  1.600 2.000kg; 			713 6405 70	
 ;  1.200 1.400 1.600kg; 				
			771 0552 30	
			814 0157 10	
			814 0158 10	
			818 0012 10	
 ↔		818 0479 10		
 ↔		818 0473 10		



			SCHAEFFLER
--	---	--	-------------------

FIAT



















































































































































DUCATO (250)				
150 Multijet 2,3 D F1AE3481E; (109kW)	06.11-	FAG	 ↔;  ↗; OPTION	 818 0480 10
			 ↔	 825 0277 10
150 Multijet 2,3 D F1AGL411A; F1AGL411C; (110kW)	04.15-	LUK	EURO 5 SAC	 625 3145 33
			EURO 6 SAC	 626 3033 33
			 Selespeed	 415 0673 10
			 SEMI;  Selespeed;  ↗	 411 0170 11
			 SEMI;  Selespeed;  ↗	 411 0253 10
				 530 0232 10
			 530 0232 30	
			 531 0505 10	
			 532 0441 10	
			 529 0383 10	
			 532 0298 10	
			 533 0061 20	
		MY 2014; EURO 6 F# F-560671.XX	 535 0235 10	
		 145 mm	 544 0017 10	
			FB 7PK1076	
			538 0130 10	
		FAG	 right	 821 0628 10
			 left	 821 0627 10
	 Set 713 6405 50			
 90 mm	 Set 713 6405 60			
 ;  1.600 2.000kg; 	 Set 713 6405 70			
 ;  1.200 1.400 1.600kg; 	 Set 771 0552 30			
	 814 0157 10			
	 814 0158 10			
	 818 0012 10			
 ↔	 818 0479 10			
 ↔	 818 0473 10			
 ↔;  ↗; OPTION	 818 0480 10			
 ↔	 825 0277 10			
 ↔	 840 0388 10			
 right	 840 1050 10			
 left	 840 1055 10			
150 Multijet 2,3 D 4x4 F1AGL411A; F1AGL411C; (110kW)	04.15-	LUK	SAC	 626 3033 33
			 Selespeed; EURO 6	 415 0673 10
				 530 0232 10
				 530 0232 30
				 531 0505 10
				 532 0441 10
EURO 6 F# F-560671.XX	 535 0235 10			
	538 0130 10			
150 Multijet 2,3 D F1AGL411A; F1AGL411C; (110kW)	12.15-	LUK	EURO 5 SAC	 625 3145 33
			EURO 6 SAC	 626 3033 33
			 Selespeed	 415 0673 10
			 SEMI;  Selespeed;  ↗	 411 0170 11
			 SEMI;  Selespeed;  ↗	 411 0253 10
				 530 0232 10
			 529 0383 10	
			 535 0235 10	
		FAG		 Set 713 6405 50
			90 mm	Set 713 6405 60
			; 1.600 2.000kg;	Set 713 6405 70
			; 1.200 1.400 1.600kg;	Set 771 0552 30
	814 0157 10			



			SCHAEFFLER
--	---	--	-------------------

FIAT

DUCATO (250)

<p>150 Multijet 2,3 D F1AGL411A; F1AGL411C; (110kW)</p>	12.15-	FAG			814 0158 10			
					818 0012 10			
					818 0479 10			
					818 0473 10			
			 ;  ; OPTION		818 0480 10			
					825 0277 10			
			right		840 1050 10			
			left		840 1055 10			
					625 3145 09			
			 ; EURO 5		625 3145 33			
					626 3033 33			
					415 0673 10			
			 ;  ; 		411 0170 11			
			 ;  ; 		411 0253 10			
<p>150 Multijet 2,3 D F1AGL411C; (110kW)</p>	12.15-	INA			530 0232 10			
					529 0383 10			
					535 0235 10			
					713 6405 50			
			 90 mm		713 6405 60			
			 ;  1.600 2.000kg; 		713 6405 70			
			 ;  1.200 1.400 1.600kg; 		771 0552 30			
					814 0157 10			
					814 0158 10			
					818 0012 10			
					818 0479 10			
					818 0473 10			
			 ;  ; OPTION		818 0480 10			
					825 0277 10			
right		840 1050 10						
left		840 1055 10						
<p>180 Multijet 2,3 D F1AGL4111; F1AGL411B; (130kW)</p>	12.15-	LUK			626 3033 33			
					415 0673 10			
			 ;  ; 		411 0170 11			
			 ;  ; 		411 0253 10			
			<p>180 Multijet 2,3 D F1AGL4111; F1AGL411B; (130kW)</p>	12.15-	INA			530 0232 10
								529 0383 10
								532 0298 10
								533 0061 20
								535 0235 10
								713 6405 50
						 90 mm		713 6405 60
						 ;  1.600 2.000kg; 		713 6405 70
						 ;  1.200 1.400 1.600kg; 		771 0552 30
								814 0157 10
		814 0158 10						
		818 0012 10						
		818 0479 10						
		818 0473 10						
 ;  ; OPTION		818 0480 10						
		825 0277 10						
right		840 1050 10						
left		840 1055 10						
<p>140 Natural Power 160 Multijet 3,0 D 180 Multijet 3,0 D F1CE0441A; F1CE0481D; F1CE3481E; F1CE3481M; F1CFA401A; (100-130kW)</p>	07.06-	LUK			626 3033 33			
					415 0375 10			
			 ;  ; 		411 0170 10			
			 ;  ; 		529 0267 10			
			<p>140 Natural Power 160 Multijet 3,0 D 180 Multijet 3,0 D F1CE0441A; F1CE0481D; F1CE3481E; F1CE3481M; F1CFA401A; (100-130kW)</p>	07.06-	INA			531 0812 10
								534 0280 10
								535 0103 10
								535 0176 10
								531 0812 10
								534 0280 10
						 ;  F-550532.XX F-556500.XX		535 0103 10
						 ;  F-559894.XX		535 0176 10





FIAT

DUCATO (250)

140 Natural Power 160 Multijet 3,0 D 180 Multijet 3,0 D F1CE0441A; F1CE0481D; F1CE3481E; F1CE3481M; F1CFA401A; (100-130kW)	07.06-		A/C		FB 4EPK1102
				FB 6PK1165	
				538 0472 10	
				821 0628 10	
				821 0627 10	
				713 6405 50	
				90 mm	
				1.600 2.000kg; I	
				1.200 1.400 1.600kg; Z	
				771 0552 30	
				814 0157 10	
				814 0158 10	
				818 0012 10	
				818 0479 10	
				818 0473 10	
				818 0480 10	
				825 0277 10	
	840 0388 10				
	840 1050 10				
	840 1055 10				
140 Multijet 3,0 D F1CE3481N; (103kW)	07.06-07.14		SAC		626 3033 33
				415 0375 10	
				411 0170 10	
				F-550532.XX F-556500.XX	
				535 0103 10	
				F-559894.XX	
				535 0176 10	
				626 3033 33	
				415 0375 10	
				411 0170 10	
150 Multijet 3,0 D F1CE3481N; (107kW)	04.10-		SAC		626 3033 33
				415 0375 10	
				411 0170 10	
				529 0267 10	
				A/C	
				531 0812 10	
				534 0280 10	
				F-550532.XX F-556500.XX	
				535 0103 10	
				F-559894.XX	
	535 0176 10				
	A/C				
	FB 4EPK1102				
	FB 6PK1165				
	538 0472 10				
	FAG right				
	821 0628 10				
	FAG left				
	821 0627 10				
	90 mm				
	713 6405 50				
	1.600 2.000kg; I				
	713 6405 60				
	1.200 1.400 1.600kg; Z				
	713 6405 70				
	814 0157 10				
	814 0158 10				
	818 0012 10				
	818 0479 10				
	818 0473 10				
	818 0480 10				
	825 0277 10				
	840 0388 10				
	840 1050 10				
	840 1055 10				
160 Multijet 3,0 D F1CE0481D; F1CE3481M; (115kW)	07.06-		SAC		626 3033 33
				415 0375 10	
				411 0170 10	
				529 0267 10	
				A/C	
				531 0812 10	
				534 0280 10	
				F-550532.XX F-556500.XX	
				535 0103 10	
				F-559894.XX	
	535 0176 10				
	A/C				
	FB 4EPK1102				
	FB 6PK1165				
	FAG right				
	821 0628 10				
	FAG left				
	821 0627 10				
	90 mm				
	713 6405 50				



			SCHAEFFLER
--	---	--	-------------------

FIAT

DUCATO (250)

160 Multijet 3,0 D F1CE0481D; F1CE3481M; (115kW)	07.06-	FAG	1.600 2.000kg;	Set	713 6405 60
			1.200 1.400 1.600kg;	Set	713 6405 70
					771 0552 30
					814 0157 10
					814 0158 10
					818 0012 10
					818 0479 10
					818 0473 10
					818 0480 10
					825 0277 10
					840 0388 10
			right		840 1050 10
			left		840 1055 10

FIORINO (225)

















































































































1.3 D Multijet (225BXD1A, 225BxB1A, 225BxB11) 199 A2.000; 199 A9.000; (55kW)	11.07-	LUK	SEMI ; Selespeed		622 3135 34
			MANU		622 3238 00
			SEMI ; Selespeed		415 0329 10
			SEMI ; Selespeed		411 0124 10
			A/C		529 0285 10
			A/C		529 0286 10
			A/C START/STOP		529 0346 10
					532 0907 10
					534 0053 10
					534 0607 10
			# F-237101.XX		535 0063 10
			# F-557928.XX		535 0151 10
					544 0029 10
					544 0035 10
					FB 4EPK1022
		A/C		FB 6PK1525	
				538 0442 10	
		1x; 199A2.000		428 0030 30	
		1x		559 0019 10	
		1x		559 0027 30	
		1x		559 0028 30	
		1x		559 0053 10	
		1x		559 0135 10	
		1x		559 0146 10	
		FAG	right		821 0575 10
			left		821 0574 10
					713 6064 00
			72 mm		713 6907 10
					771 0077 30
			84 mm		772 0437 30
			BMW Euro 5; MANU		818 0230 10
					825 0274 10
					840 0395 10
right			840 1060 10		
left			840 1061 10		
			532 0907 10		
# F-237101.XX			535 0063 10		
EURO 6			535 0151 10		
# F-557928.XX			FB 6PK1525		
A/C			FB 6PK1525		
FAG	right			821 0575 10	
	left			821 0574 10	
			713 6064 00		
	72 mm		713 6907 10		
			771 0077 30		
	84 mm		818 0230 10		
			840 0395 10		
	right		840 1060 10		
	left		840 1061 10		



			SCHAEFFLER
--	---	--	-------------------

FIAT

FIORINO (225)

















































1.3 D Multijet (225BXE1A) 199 B1.000; 330 A1.000; (70kW)	07.09-	 	 ; A/C	 622 3238 00	 529 0380 10
				 532 0907 10	 534 0455 10
			 # F-237101.XX	 535 0063 10	 535 0151 10
			 # F-557928.XX	 544 0029 10	 FB 6PK1525
			 ; A/C	 FB 6PK1670	 538 0442 10
			A/C	 FB 6PK1670	 420 0181 10
			16x	 422 0064 10	 559 0019 10
			 12 mm	 559 0027 30	 559 0028 30
			16x	 559 0053 10	 559 0135 10
			1x	 559 0146 10	 821 0575 10
			1x	 821 0574 10	 713 6064 00
			1x	 713 6907 10	 771 0077 30
			1x	 772 0437 30	 818 0230 10
			1x	 825 0274 10	 840 0395 10
			1x	 840 1060 10	 840 1061 10
		1x	 462 0151 10	 620 3086 00	
		1x	 620 3086 21	 620 3086 22	
		1x	 530 0335 10	 530 0335 30	
		1x	 531 0572 10	 532 0331 10	
		1x	 534 0179 10	 544 0145 10	
		1x	 FB 6PK1565	 538 0055 10	
		1x	 821 0575 10	 821 0574 10	
		1x	 713 6063 90	 713 6907 10	
		1x	 818 0230 10	 825 0274 10	
		1x	 840 0395 10	 840 1060 10	
1x	840 1061 10	620 3445 00			
1.4 (225BXA1A, 225BXF1A) KFT; KfV; (54kW)	11.07-	 	G5 ; MA	 GearBOX	 620 3086 00
			LHD	 620 3086 21	 620 3086 22
			incl. 	 530 0335 10	 530 0335 30
			RHD	 531 0572 10	 532 0331 10
			incl. 	 534 0179 10	 544 0145 10
			 KfV	 FB 6PK1565	 538 0055 10
			 KfV	 821 0575 10	 821 0574 10
			 KfV	 713 6063 90	 713 6907 10
			 KfV	 818 0230 10	 825 0274 10
			 KfV	 840 0395 10	 840 1060 10
		 ; A/C	 840 1061 10	 620 3445 00	
		 ; A/C	 530 0462 10	 530 0462 30	
		1x	 531 0778 10	 529 0013 10	
		1x	 FB 4PK668	 538 0062 10	
		1x	427 0009 10	427 1001 30	
1x	428 0166 10	821 0575 10			
1x	821 0574 10				
1.4 Natural Power (225BXC1A, 225AXC1A) 350 A1.000; (57kW)	06.08-	 	 ; A/C	 530 0462 10	 530 0462 30
			 ; A/C	 531 0778 10	 529 0013 10
			1x	 FB 4PK668	 538 0062 10
			1x	 427 0009 10	 427 1001 30
			1x	 428 0166 10	 821 0575 10
			1x	 821 0574 10	
			1x		
			1x		
			1x		
			1x		
		1x			
		1x			
		1x			
		1x			
		1x			











































































			SCHAEFFLER
--	--	--	-------------------

FIAT

FIORINO (225)

1.4 Natural Power (225BXC1A, 225AXC1A) 350 A1.000; (57kW)	06.08-	FAG	  Set 713 6063 90			
			 72 mm  Set 713 6907 10			
			  SET 772 0276 30			
			  818 0230 10			
			  825 0274 10			
			 ↔  840 0395 10			
			 right  840 1060 10			
			 left  840 1061 10			
			1.4 (225AXA1A, 225BXA1A) 350 A1.000; (57kW)	10.09-	LUK	  620 3105 00
						  530 0462 10
  KIT+  530 0462 30						
  531 0778 10						
 ; A/C  529 0013 10						
 ; A/C  544 0145 10						
  FB 4PK668						
 1x  538 0062 10						
FAG	 1x  427 0009 10					
	  427 1001 30					
	 right  428 0166 10					
	 left  821 0575 10					
	 72 mm  821 0574 10					
	  Set 713 6063 90					
	  Set 713 6907 10					
	 ↔  818 0230 10					

SCUDO













































































































1.6 D Multijet 9HU; (66kW)	01.07-	LUK	  624 3218 00
			 DV6UTED4; →09.11  530 0375 10
			 DV6UTED4  530 0375 10
			 DV6UTED4; →09.11  KIT+  530 0375 30
			 DV6UTED4  KIT+  530 0375 30
			 DV6UTED4  531 0555 10
			 DV6UTED4  532 0321 10
			 ; A/C; →03.16  529 0046 10
			 ; A/C  KIT  529 0404 10
			 ; 2x; DV6UTED4  532 0538 10
			 ; DV6UTED4  534 0400 10
			 # F-232369.04/.05/.07 F-232369.08  535 0059 10
		 # F-236591.05/.07  535 0194 10	
		  544 0104 10	
		 ; A/C  544 0104 20	
		 DV6UTED4  FB 6PK1705	
		  538 0037 10	
		  428 0032 30	
		FAG	 right;  821 0718 10
			 left;  821 0717 10
			  713 0014 20
			  Set 713 6405 40
			 86 mm  Set 713 6405 20
			 ;  Set 713 6405 30
			 ; I STANDARD  814 0125 10
			 ; I STANDARD  814 0126 10
			  818 0011 10
			  818 0375 10
			  840 0332 10
			  840 1062 10
LUK	  623 3325 00		
	  530 0578 10		
	  KIT+  530 0578 30		
	  531 0850 10		
	; A/C; →03.16 532 0624 10		

1.6 D Multijet
9H07 (DV6UC); 9HM (DV6UC);
(66kW)



			SCHAEFFLER
--	--	--	-------------------

FIAT

FIAT				
SCUDO				
1.6 D Multijet 9H07 (DV6UC); 9HM (DV6UC); (66kW)	02.11-		 ; A/C	 529 0404 10
			 ; 2x	 532 0538 10
				 534 0400 10
			## F-232369.04/.05/.07 F-232369.08	 535 0059 10
			## F-236591.05/.07	 535 0194 10
				 544 0104 10
			 ; A/C	 FB 6PK1708
				 538 0037 10
			8x	 420 0086 10
			 12 mm	
		8x	 422 0018 10	
		1x	 428 0183 10	
		FAG	 right;	 821 0718 10
			 left;	 821 0717 10
				 Set 713 6405 40
			 86 mm	
				 Set 713 6405 20
				 Set 713 6405 30
			 ; I STANDARD	 814 0125 10
			 ; I STANDARD	 814 0126 10
	 818 0011 10			
	 818 0375 10			
	 840 0332 10			
	 840 1062 10			
2.0 D Multijet RHK; (88kW)	01.07-	LUK	incl.  ; incl.  ; SAC	 600 0136 00
			SAC	 624 3267 00
				 415 0320 10
				 411 0159 10
				 530 0449 10
				 530 0449 30
				 531 0756 10
				 532 0473 10
			 ; →07.07	 529 0105 10
			 ; A/C	 532 0650 10
				 534 0334 10
			## F-232369.04/.05/.07 F-232369.08	 535 0059 10
			## F-550426.XX	 535 0149 10
				 544 0095 10
				 544 0097 10
			 A/C	 FB 6PK1218
				 538 0428 10
			16x	 420 0243 10
			 12 mm	
			 ; 1x	 428 0160 10
 ; 1x	 428 0168 10			
1x	 KIT 559 0111 10			
FAG	 right;	 821 0718 10		
	 left;	 821 0717 10		
		 Set 713 0014 20		
		 Set 713 6405 40		
	 86 mm			
		 Set 713 6405 20		
		 Set 713 6405 30		
	 left	 771 0603 30		
	 ; I STANDARD	 814 0125 10		
	 ; I STANDARD	 814 0126 10		
	 818 0011 10			
	 818 0375 10			
	 840 0332 10			
	 840 1062 10			
2.0 D Multijet 4x4 RHK; (88kW)	01.07-	LUK	incl.  ; incl.  ; SAC	 600 0136 00
			SAC	 624 3267 00
			 415 0320 10	
			 411 0159 10	
			 530 0449 10	
	 530 0449 30			



			SCHAEFFLER
--	---	--	-------------------

FIAT

SCUDO

2.0 D Multijet 4x4
 RHK; (88kW)

01.07-



	531 0756 10
	532 0473 10
	534 0334 10
	535 0149 10
	544 0095 10
	544 0097 10
	544 0097 20
	538 0428 10
	428 0160 10
	428 0168 10
1x	559 0111 10
	821 0718 10
	821 0717 10
	713 0014 20
	713 6405 40
	86 mm
	G6
	STANDARD
	STANDARD
	818 0011 10
	818 0375 10
	840 0332 10
	840 1062 10

FAG

2.0 D Multijet
 RH02; (94kW)

05.11-



	624 3898 00
	530 0558 10
	530 0558 31
	531 0839 10
	532 0473 10
	534 0369 10
	535 0149 10
	535 0194 10
	DW10CD
	544 0095 10
	544 0097 10
	544 0097 20
	FB 6PK1218
	DW10CD
	538 0102 10
16x	420 0232 10
	12 mm
8x;	422 0124 10
8x;	422 0125 10
1x;	428 0189 10
1x;	428 0190 10
1x	559 0111 10
	821 0718 10
	821 0717 10
	713 0014 20
	713 6405 40
	86 mm
	713 6405 20
	713 6405 30
	STANDARD
	STANDARD
	818 0011 10
	818 0375 10
	840 0332 10
	840 1062 10

FAG

2.0 D Multijet
 DW10BTED4; RHR; (100kW)

01.07-























































































































	incl. ; incl. ; SAC	600 0136 00
	SAC	624 3267 00
		415 0320 10
		411 0159 10
		530 0449 10
		530 0449 30
		531 0756 10
		532 0473 10
	; →07.07	529 0105 10
		534 0334 10
	F-232369.04/.05/.07 F-232369.08	535 0059 10
	F-550426.XX	535 0149 10



			SCHAEFFLER
--	---	--	-------------------

FIAT

SCUDO



























2.0 D Multijet DW10BTE4; RHR; (100kW)	01.07-				544 0095 10
					544 0097 10
					544 0097 20
			16x		FB 6PK1218
			 12 mm		538 0428 10
			 ; 1x		420 0243 10
			 ; 1x		428 0160 10
			1x		428 0168 10
		FAG	 right; 		559 0111 10
			 left; 		821 0718 10
					821 0717 10
					713 0014 20
			 86 mm		Set 713 6405 40
			 ; 		Set 713 6405 20
			 ; 		Set 713 6405 30
			 left		771 0603 30
			 ;  ; ISTANDARD		814 0125 10
			 ;  ; ISTANDARD		814 0126 10
					818 0011 10
			 ; 		818 0375 10
					840 0332 10
					840 1062 10
					624 3417 00
					415 0529 10
					411 0159 10
					530 0558 10
					530 0558 31
					531 0839 10
				532 0473 10	
				534 0369 10	
				535 0149 10	
				535 0194 10	
				544 0095 10	
				544 0097 10	
				544 0097 20	
					FB 6PK1218
					538 0102 10
			16x		420 0232 10
			 12 mm		422 0124 10
			8x; 		422 0125 10
			8x; 		428 0189 10
			1x; 		428 0190 10
			1x; 		428 0190 10
			1x		559 0111 10
		FAG	 right; 		821 0718 10
			 left; 		821 0717 10
					713 0014 20
					Set 713 6405 40
			 86 mm		Set 713 6405 20
			 ; 		Set 713 6405 30
			 ; 		Set 713 6405 30
			 ;  ; ISTANDARD		814 0125 10
			 ;  ; ISTANDARD		814 0126 10
					818 0011 10
			 ; 		818 0375 10
					840 0332 10
					840 1062 10
					
SCUDO (220 _)					
2.0 JTD RHZ; (80kW)	12.02-12.06		VET → 10249		600 0048 00
			VET 10289 → VET → 10559 incl.  ; incl. 		623 3041 21
			VET → 10249		
			VET 10289 → VET → 10559 incl. 		624 3078 00
			VET 10250 → VET → 10288		
			VET 10560 →		





































































			SCHAEFFLER
--	--	--	-------------------

FIAT











SCUDO (220_)

2.0 JTD RHZ; (80kW)	12.02-12.06				415 0138 10
		FAG	 right; VET 6943→VET →10844		411 0159 10
			 left; VET 6943→VET →10844		821 0425 10
					821 0424 10
			 82,5 mm		713 6305 80
			 ; ABS		713 6305 70
			 ; ABS		713 6505 30
					814 0125 10
					814 0126 10
					818 0233 10
			 ↔		840 0209 10
			 ; →05.03		840 0923 10
			 ; 06.03→		840 1003 10

SCUDO (220P/L)

2.0 JTD RHZ; (80kW)	12.02-12.06		VET →10249		600 0048 00	
			VET 10289→VET →10559 incl. 		623 3041 21	
			VET →10249 VET 10289→VET →10559 incl. 			
			VET 10250→VET →10288 VET 10560→		624 3078 00	
				415 0138 10		
				411 0159 10		
						530 0470 10
						530 0470 30
						531 0780 10
						532 0345 10
			 ; A/C		529 0017 10	
			 ; A/C		529 0156 10	
			 ; A/C		532 0143 10	
					534 0110 20	
			 # F-229603.XX		535 0039 10	
			 # F-232369.04/.05/.07 F-232369.08		535 0059 10	
			 # F-236591.05/.07		535 0194 10	
			→11.04		544 0039 10	
			12.04→		544 0058 10	
			→11.04		544 0039 20	
			12.04→		544 0058 20	
					538 0008 10	
		1x		428 0034 30		
		1x		559 0111 10		
		FAG	 right; VET 6943→VET →10844		821 0425 10	
			 left; VET 6943→VET →10844		821 0424 10	
					713 0014 20	
					713 6305 80	
			 82,5 mm		713 6305 70	
			 ; ABS		713 6505 30	
			 ; ABS		713 6505 30	
			 100,45 mm		771 0055 30	
			 100 mm		771 0059 30	
					772 0259 30	
					814 0125 10	
					814 0126 10	
					818 0233 10	
					840 0209 10	
			 ; →05.03		840 0923 10	
			 ; 06.03→		840 1003 10	

TALENTO (290, 296)













































1.6 D R9M 408; R9M 413; (70-85kW)	06.16-		SAC		624 3930 09
					415 0796 10
					532 0534 10
					534 0624 10
		 # F-236675.XX F-561464.XX		535 0080 10	



			SCHAEFFLER
--	---	--	-------------------















FIAT

TALENTO (290, 296)

1.6 D R9M 408; R9M 413; (70-85kW)	06.16-		F-552305.XX A/C; R9M 408	 535 0153 10			
			A/C; R9M 413	 FB 7PK1685			
			A/C; R9M 450				
			16x 12 mm	 538 0399 10	 420 0086 10		
			16x	 422 0078 10			
			FAG	↔	 818 0207 10		
		right		 840 0274 10			
		left		 840 0880 10			
		left		 840 0879 10			
		1.6 D R9M 413; (89kW)	06.16-		SAC	 624 3930 09	
						 415 0796 10	
					A/C; R9M 450	 532 0534 10	
					A/C; R9M 452	 534 0624 10	
					F-236675.XX F-561464.XX	 535 0080 10	
					F-552305.XX	 535 0153 10	
A/C; R9M 450	 FB 7PK1325						
A/C; R9M 452							
A/C; R9M 450	 FB 7PK1675						
A/C; R9M 408	 FB 7PK1685						
A/C; R9M 413							
A/C; R9M 450	 538 0399 10				 420 0086 10		
16x 12 mm							
16x	 422 0078 10						
FAG	↔			 818 0207 10			
	right	 840 0274 10					
	left	 840 0880 10					
	left	 840 0879 10					
1.6 D R9M 452; (92-107kW)	06.16-		SAC	 624 3930 09			
				 415 0796 10			
			A/C; R9M 450	 532 0534 10			
			A/C; R9M 452	 534 0624 10			
			F-236675.XX F-561464.XX	 535 0080 10			
			F-552305.XX	 535 0153 10			
			A/C; R9M 450	 FB 7PK1325			
			A/C; R9M 452				
			A/C; R9M 450	 FB 7PK1675			
			A/C; R9M 452	 538 0399 10	 420 0086 10		
			16x 12 mm				
			16x	 422 0078 10			
		FAG	↔	 818 0207 10			
			right	 840 0274 10			
			left	 840 0880 10			
left	 840 0879 10						

FORD

TRANSIT / TOURNEO CONNECT



























































































1.0 EcoBoost B3GA; M2GA; M2GB; (74kW)	02.13-		G5; MTX75 →05.18 incl.	GearBOX	462 0153 10
				 624 3739 33	
				 415 0873 10	
			OILP	 530 0700 10	
			A/C	 529 0337 10	
			A/C	 529 0338 10	
			A/C	 532 0782 10	
			A/C	 534 0507 10	
			# 920444	 535 0284 10	
			02.18→; A/C	 FB 6PK1250	 FB 6PK1503
			2x	 538 0266 10	 427 0038 10
		1x;	 427 1031 10		



			<p>SCHAEFFLER</p>
--	---	--	--------------------------

FORD

TRANSIT / TOURNEO CONNECT











































































































<p>1.0 EcoBoost  B3GA; M2GA; M2GB; (74kW)</p>	<p>02.13-</p>	<p> FAG</p>	<p>1x;  1x  82 mm  ↔  ↔  right  left</p>	<p> 427 1032 10  711 0308 10  Set 713 6789 70  Set 713 6791 80  818 0317 10  840 0376 10  840 1131 10  840 1130 10</p>
<p>1.5 TDCi  XUGA; (55kW)</p>	<p>08.15-</p>	<p>  FAG</p>	<p>G5;  MTX75 →05.18; G5 G6 SAC →05.18; G5 →05.18; G6 SAC  8x  12 mm 8x 1x  82 mm  ↔  ↔  right  left</p>	<p>GearBOX 462 0153 10  624 4034 09  624 4034 33  624 4034 34  530 0698 10  KIT 530 0698 30  KIT 531 0829 10  532 0624 10  KIT 529 0298 10  KIT 535 0237 10  538 0037 10  420 0086 10  422 0018 10  428 0183 10  Set 713 6789 70  Set 713 6791 80  818 0317 10  840 0376 10  840 1131 10  840 1130 10</p>
<p>1.5 TDCi  XVGA; XVGB; XVGC; XXGA; (74kW)</p>	<p>05.15-</p>	<p>  FAG</p>	<p>G5;  MTX75 →05.18; G5 G6 SAC →05.18; G5 →05.18; G6 SAC  8x  12 mm 8x 1x  82 mm  ↔  ↔  right  left</p>	<p>GearBOX 462 0153 10  624 4034 09  624 4034 33  624 4034 34  530 0698 10  KIT 530 0698 30  KIT 531 0829 10  532 0624 10  KIT 529 0298 10  KIT 535 0236 10  KIT 535 0237 10  544 0104 10  544 0104 20  538 0037 10  420 0086 10  422 0018 10  428 0183 10  Set 713 6789 70  Set 713 6791 80  818 0317 10  840 0376 10  840 1131 10  840 1130 10</p>
<p>1.5 TDCi  XWGA; XWGB; XWGC; (88kW)</p>	<p>05.15-</p>	<p> </p>	<p>→05.18; G6 incl. ; incl. ; SAC →05.18; G6 SAC →05.18 incl. </p>	<p> 600 0277 00  624 3774 33  415 0537 11  530 0698 10  KIT 530 0698 30  KIT 531 0829 10</p>



			SCHAEFFLER
--	---	--	-------------------

FORD

TRANSIT / TOURNEO CONNECT

































1.5 TDCi XWGA; XWGB; XWGC; (88kW)	05.15-		 ; A/C	 529 0298 10			
			 # 920006	 535 0236 10			
			 # 920007	 535 0237 10			
				 544 0104 10			
				 544 0104 20			
			8x  12 mm	 420 0086 10			
			8x	 422 0018 10			
			1x	 428 0183 10			
			FAG  82 mm	 Set 713 6789 70			
				 Set 713 6791 80			
			 ↔	 818 0317 10			
			 ↔	 840 0376 10			
			 right	 840 1131 10			
			 left	 840 1130 10			
			1.6 TDCi TZGA; TZGB; UBGA; (55-70kW)	02.13-		LUK G5 ;  MTX75	GearBOX 462 0153 10
G6 SAC	 624 3952 33						
09.13 → +  ; 	 530 0611 10  530 0612 10						
+  ; 	 530 0612 30						
09.13 → +  ; 	 531 0883 10  531 0884 10						
 ; 04.14 → ; A/C	 529 0261 10						
 ; A/C	 529 0298 10						
	 534 0075 20						
 # 920006	 535 0236 10						
 # 920007	 535 0237 10						
	 544 0104 10						
	 544 0104 20						
 ; A/C	 FB 6PK800						
	 538 0037 10						
8x  12 mm	 420 0086 10						
8x	 422 0018 10						
1x	 428 0183 10						
FAG  82 mm	 Set 713 6789 70						
	 Set 713 6791 80						
 ↔	 818 0317 10						
 ↔	 840 0376 10						
 right	 840 1131 10						
 left	 840 1130 10						
1.6 TDCi T1GA; (85kW)	02.13-					LUK G5 ;  MTX75	GearBOX 462 0153 10
						G6 SAC	 624 3952 33
						incl. 	 415 0537 11
						09.13 → +  ; 	 530 0611 10  530 0612 10
						+  ; 	 530 0612 30
						09.13 → +  ; 	 531 0883 10  531 0884 10
						 ; 04.14 → ; A/C	 529 0261 10
			 ; A/C	 529 0298 10			
				 534 0075 20			
			 # 920006	 535 0236 10			
			 # 920007	 535 0237 10			
				 544 0104 10			
				 544 0104 20			
			 ; A/C	 FB 6PK800			
				 538 0037 10			
			8x  12 mm	 420 0086 10			
			8x	 422 0018 10			
			1x	 428 0183 10			
			FAG  82 mm	 Set 713 6789 70			
				Set 713 6791 80			

















































































			SCHAEFFLER
--	--	--	-------------------

FORD

TRANSIT / TOURNEO CONNECT

1.6 TDCi T1GA; (85kW)	02.13-	FAG	 ↔		818 0317 10	
			 ↔		840 0376 10	
			 right		840 1131 10	
			 left		840 1130 10	
1.6 EcoBoost JQGA; (110kW)	11.13-				530 0605 10	
					530 0605 30	
					531 0877 10	
					532 0655 10	
					FB 6PK1555	
					538 0264 10	
		FAG	1x			711 0308 10
			 82 mm			713 6789 70
					713 6791 80	
			 ↔		818 0317 10	
			 ↔		840 0376 10	
			 right		840 1131 10	
		 left		840 1130 10		

TRANSIT / TOURNEO COURIER

















































































































1.0 EcoBoost SFCA; SFCB; SFCC; SFCD; SFCE; SFCF; (74kW)	02.14-		→03.18		623 3741 33	
			 OILP; EURO 6		530 0700 10	
			 ; A/C		529 0337 10	
			 ; A/C		529 0338 10	
					532 0782 10	
					534 0507 10	
			 ; S ; 150 120 A; # OE CV6T-10300-BC CV6T-10300-BE CV6T-10300-FA # F-580452		535 0268 10	
			 ; 02.18 →; A/C		FB 6PK1250	
					FB 6PK1503	
					538 0266 10	
			2x		427 0038 10	
			1x; 		427 1031 10	
			1x; 		427 1032 10	
			1x		711 0308 10	
			FAG			713 6157 30
				 72 mm		713 6792 30
						713 6792 30
						818 0454 10
 right		840 1129 10				
 left		840 1128 10				
1.5 TDCi UGCA; UGCB; XUCC; XUCD; XU- CE; XWCA; XWCB; (55kW)	02.14-		→03.18		622 3231 33	
			04.18 →		622 3456 09	
			 UGCA UGCB; + ;		530 0611 10	
			 XUCC XUCD XWCA XWCB		530 0698 10	
			 UGCA UGCB; + ;		530 0611 30	
			 XUCC XUCD XWCA XWCB		530 0698 30	
			 XUCC XUCD XWCA XWCB		531 0829 10	
			 UGCA UGCB; + ;		531 0883 10	
			 ; A/C		529 0213 10	
			 ; A/C		529 0261 10	
					534 0075 20	
			# 920006		535 0236 10	
			# 920007		535 0237 10	
					544 0104 10	
					544 0104 20	
					538 0037 10	
			8x		420 0086 10	
			 12 mm			
			8x		422 0018 10	
			1x		428 0183 10	
FAG			713 6157 30			
	 72 mm		713 6792 30			
			713 6792 30			
			818 0454 10			
		 right		840 1129 10		
		 left		840 1128 10		



			SCHAEFFLER
--	---	--	-------------------

FORD

TRANSIT / TOURNEO COURIER





































































<p>1.5 TDCi  XVCA; XVCB; XVCC; XVCD; (70kW)</p>	<p>05.15-</p>	<p></p>	→03.18		622 3231 33	
			04.18→		622 3456 09	
					530 0698 10	
					530 0698 30	
					531 0829 10	
					532 0624 10	
			 ; A/C		529 0213 10	
			 ; A/C		529 0261 10	
					534 0075 20	
			 # 920006		535 0236 10	
			 # 920007		535 0237 10	
					544 0104 10	
					544 0104 20	
					538 0037 10	
			8x		420 0086 10	
 12 mm						
8x		422 0018 10				
1x		428 0183 10				
<p>FAG</p>				Set	713 6157 30	
		 72 mm				
					Set	713 6792 30
						818 0454 10
		 right				840 1129 10
		 left				840 1128 10
<p>1.5 EcoBlue  XXCA; XXCB; XXCC; (74kW)</p>	<p>04.18-</p>	<p></p>			622 3456 09	
					530 0698 10	
					530 0698 30	
					531 0829 10	
					532 0624 10	
					534 0075 20	
			 # 920007		535 0237 10	
					544 0104 10	
			 ; A/C		FB 6PK800	
			 ; A/C		FB 6PK948	
<p>1.6 TDCi  T3CA; T3CB; T3CC; (70kW)</p>	<p>02.14-</p>	<p></p>			622 3231 33	
					530 0611 10	
					530 0611 30	
					531 0883 10	
			 ; 04.14→; A/C		529 0261 10	
			 ; A/C		529 0298 10	
					534 0075 20	
			 # 920006		535 0236 10	
			 # 920007		535 0237 10	
					544 0104 10	
					544 0104 20	
			 ; A/C		FB 6PK800	
					538 0037 10	
			8x		420 0086 10	
			 12 mm			
8x		422 0018 10				
1x		428 0183 10				
<p>FAG</p>				Set	713 6157 30	
		 72 mm				
					Set	713 6792 30
						818 0454 10
		 right				840 1129 10
		 left				840 1128 10
TRANSIT / TOURNEO CUSTOM						
<p>2.0 EcoBlue  BJFA; BJFB; BKFA; BKFB; YLF6; YLFA; YLFB; YLFS; YMF6; YMFA; YMFB; YMFS; (77-96kW)</p>	<p>12.15-</p>	<p></p>	 # 920620		535 0310 10	
					FB 3PK715	
			 ; A/C		FB 6PK1340	
			 ; A/C		FB 6PK1413	
					Set	713 6791 20
			 ; →10.18		Set	713 6791 50
			 ;  250, 260, 270, 280 290, 300, 310		Set	713 6791 60
			 ;  330, 350, 390, 410 470		Set	713 6791 60
 ↔			818 0318 10			
 ↔; I STANDARD			825 0104 10			















































			<p>SCHAEFFLER</p>
--	--	--	--------------------------

FORD

TRANSIT / TOURNEO CUSTOM

<p>2.0 EcoBlue  BJFA; BJFB; BKFA; BKFB; YLF6; YLFA; YLFB; YLFS; YMF6; YMFA; YMFB; YMFS; (77-96kW)</p>	<p>12.15-</p>	<p>FAG</p>	<p> ↔  ↔</p>	<p> 840 0775 10  840 1279 10</p>
<p>2.0 EcoBlue  BLFA; BLFB; YNF6; YNFA; YNFB; YNFS; (125kW)</p>	<p>12.15-</p>	<p> FAG</p>	<p> # 920620  ; A/C  ; →10.18  ;  250, 260, 270, 280 290, 300, 310  ;  330, 350, 390, 410 470  ↔  ↔; ISTANDARD  ↔  ↔</p>	<p> 535 0310 10  FB 6PK1340  Set 713 6791 20  Set 713 6791 50  Set 713 6791 60  818 0318 10  825 0104 10  840 0775 10  840 1279 10</p>
<p>2.2 TDCi  CVFF; CYF4; CYFF; DRF4; DRFF; DRFG; (74-114kW)</p>	<p>04.12-</p>	<p>LUK </p>	<p>incl.  ; SAC SAC  ; A/C  ; 09.12→; A/C START/STOP  ; 09.12→; A/C  ; →12.14; RWD 4WD ; A/C  ; →12.14; RWD 4WD ; A/C # F-554766.XX  ; 09.12→; FWD  ; 09.12→; FWD ; A/C  ; 09.12→; A/C 1x FAG  ; →10.18  ;  250, 260, 270, 280 290, 300, 310  ;  330, 350, 390, 410 470  ↔  ↔; ISTANDARD  ↔  ↔</p>	<p> 600 0315 00  626 3093 33  415 0562 10  411 0120 10  532 0470 10  532 0477 10  532 0910 10  534 0308 10  534 0682 10  535 0160 10  FB 4EPK922  FB 6EPK873  FB 6PK1670  538 0465 10  KIT 558 0062 10  Set 713 6791 20  Set 713 6791 50  Set 713 6791 60  818 0318 10  825 0104 10  840 0775 10  840 1279 10</p>



















































































































TRANSIT V (F_)

<p>2.0 TDCi (F_F_, F_E_, F_G_)  F1FA; (92kW)</p>	<p>08.02-05.06</p>	<p>LUK </p>	<p>SAC →11.03 12.03→  ; A/C  ; A/C  ; A/C # F-556615.01  ; FWD ; A/C 1x 1x; →03.04 1x; →03.04 1x; 03.04→ 1x; 03.04→ FAG  right  left  ; ABS ; →06.03;  BM 330, 350  ; ABS ;  BM 260, 280, 300  ; ABS ; 07.03→;  BM 330, 350  ;  </p>	<p> 624 3229 33  415 0168 10  415 0378 10  411 0120 10  529 0104 10  532 0470 10  532 0471 10  534 0169 10  535 0223 10  FB 4PK735  FB 6PK1640  538 0259 10  538 0260 10  KIT 558 0064 10  KIT 559 0187 10  KIT 559 0187 30  KIT 559 0188 10  KIT 559 0188 30  821 0264 10  821 0263 10  713 0390 20  Set 713 6786 50  Set 713 6786 60  Set 713 6786 60  Set 713 6787 20  771 0600 30  814 0052 10</p>
--	--------------------	---	---	--



			SCHAEFFLER
--	---	--	-------------------

FORD































































































TRANSIT V (F _)					
2.0 TDCi (F_F_, F_E_, F_G_) FIFA; (92kW)	08.02-05.06	FAG	 ; FWD ;  BM 260, 280, 300		818 0304 10
			 ; RWD		818 0318 10
			 ; FWD ;  BM 330, 350		818 0152 10
					825 0104 10
			 ; LHD		840 0134 10
			 ; RHD		
			 ; LHD		840 0284 10
			 ; RHD		
					840 0775 10
					624 3229 33
2.0 TDCi (F_E_, F_F_) FIFA; (92kW)	08.02-05.06	LUK	SAC		415 0168 10
			→11.03		415 0378 10
			12.03→		411 0120 10
					529 0104 10
			 ; A/C		532 0470 10
			 ; A/C		532 0471 10
			 ; A/C		534 0169 10
			## F-556615.01		535 0223 10
					FB 4PK735
			 ; FWD ; A/C		FB 6PK1640
					538 0259 10
					538 0260 10
			1x		558 0064 10
			1x; →03.04		559 0187 10
			1x; →03.04		559 0187 30
			1x; 03.04→		559 0188 10
			1x; 03.04→		559 0188 30
			1x; →03.04		559 0189 10
		→03.04; 1x		559 0189 30	
		FAG	 right		821 0264 10
			 left		821 0263 10
					713 0390 20
					713 6786 50
			 ; ABS ; →06.03;  BM 330, 350		713 6786 60
			 ; ABS ;  BM 260, 280, 300		713 6786 60
			 ; ABS ; 07.03→;  BM 330, 350		713 6787 20
					771 0600 30
					814 0052 10
 ; FWD ;  BM 260, 280, 300			818 0304 10		
 ; RWD			818 0318 10		
 ; FWD ;  BM 330, 350			818 0152 10		
			825 0104 10		
 ; LHD			840 0134 10		
 ; RHD					
 ; LHD		840 0284 10			
 ; RHD					
		840 0775 10			
2.3 E5FC; (105kW)	03.01-03.06	LUK	06.02→		624 3309 00
			SAC		415 0169 10
			→04.02		415 0355 10
			05.02→		512 0359 10
			## F-234359.XX F-552016.XX		535 0037 10
			 ; A/C		FB 6PK1955
		FAG	 right		821 0264 10
			 left		821 0263 10
					713 6786 50
					814 0052 10
			 ; FWD ;  BM 260, 280, 300		818 0304 10
			 ; RWD		818 0318 10
			 ; FWD ;  BM 330, 350		818 0152 10
					825 0104 10



			<p>SCHAEFFLER</p>
--	--	--	--------------------------

FORD

TRANSIT V (F_)





































































<p>2.3 E5FC; (105kW)</p>	<p>03.01-03.06</p>	<p>FAG</p>	<p> ; LHD  ; RHD  ; LHD  ; RHD</p>	<p> 840 0134 10  840 0284 10</p>
<p>2.3 BiFuel E5FA; (105kW)</p>	<p>03.01-03.06</p>	<p>FAG</p>	<p> right  left  ; FWD ;  BM 260, 280, 300  ; RWD  ; FWD ;  BM 330, 350  ; LHD  ; RHD  ; LHD  ; RHD</p>	<p> 840 0775 10  821 0264 10  821 0263 10  814 0052 10  818 0304 10  818 0318 10  818 0152 10  825 0104 10  840 0134 10  840 0284 10  840 0775 10</p>
<p>2.3 E5FA; (107kW)</p>	<p>03.01-03.06</p>	<p>LUK</p>	<p>06.02→ SAC →04.02 05.02→ 05.02→  # F-234359.XX F-552016.XX  ; A/C 1x FAG  right  left  ; FWD ;  BM 260, 280, 300  ; RWD  ; FWD ;  BM 330, 350  ; LHD  ; RHD  ; LHD  ; RHD</p>	<p> 624 3309 00  415 0169 10  415 0355 10  512 0359 10  535 0037 10  FB 6PK1955  538 0270 10  OILP 553 0151 10  821 0264 10  821 0263 10  Set 713 6786 50  814 0052 10  818 0304 10  818 0318 10  818 0152 10  825 0104 10  840 0134 10  840 0284 10  840 0775 10</p>
<p>2.3 16V (F_A_, F_B_, F_C_, F_D_) E5FA; E5FC; (107kW)</p>	<p>04.01-05.06</p>	<p>LUK</p>	<p>06.02→ SAC →04.02 05.02→ 05.02→  # F-234359.XX F-552016.XX  ; A/C 1x FAG  right  left  ;  BM 260, 280, 300  ;  BM 330, 350  ; 05.01→  ; LHD  ; RHD  ; LHD  ; RHD</p>	<p> 624 3309 00  415 0169 10  415 0355 10  512 0359 10  535 0037 10  FB 6PK1955  538 0270 10  OILP 553 0151 10  821 0264 10  821 0263 10  Set 713 0390 20  Set 713 6786 50  Set 713 6784 20  771 0600 30  814 0052 10  818 0304 10  818 0318 10  818 0152 10  825 0104 10  840 0134 10  840 0284 10  840 0775 10</p>



			SCHAEFFLER
--	--	--	-------------------

FORD

TRANSIT V (F _)

























































































































2.3 16V RWD (FAA_, FAB_, FAC_) E5FA; E5FC; (107kW)	04.01-05.06		06.02→ SAC		624 3309 00
			→04.02		415 0169 10
			05.02→		415 0355 10
			05.02→		512 0359 10
			F# F-234359.XX F-552016.XX A/C		535 0037 10
			A/C		FB 6PK1780
					FB 6PK1955
			1x		538 0270 10
		FAG	right		553 0151 10
			left		821 0264 10
					821 0263 10
					713 0390 20
					713 6786 50
					713 6784 20
					771 0600 30
					814 0052 10
			FWD; BM 260, 280, 300 RWD		818 0304 10
			FWD; BM 330, 350		818 0318 10
			; 05.01→		818 0152 10
					825 0104 10
			; LHD		840 0134 10
			; RHD		
			; LHD		840 0284 10
			; RHD		
					840 0775 10
2.4 TDi D2FE; (66kW)	10.01-03.06		A/C		529 0389 10
			A/C		529 0390 10
					532 0449 10
					534 0031 10
			F# F-237045.XX		535 0087 10
			F# F-563432.XX		535 0159 10
			# 920583		535 0314 10
			A/C; # OE 1129181		FB 7PK2710
					538 0262 10
			1x		558 0065 10
			1x; →03.04		559 0189 10
			→03.04; 1x		559 0189 30
		FAG	right		821 0264 10
			left		821 0263 10
					771 0600 30
					814 0052 10
			FWD; BM 260, 280, 300 RWD		818 0304 10
			FWD; BM 330, 350		818 0318 10
			; 05.01→		818 0152 10
					825 0104 10
			; LHD		840 0134 10
			; RHD		
			; LHD		840 0284 10
			; RHD		
					840 0775 10
2.4 TDE FXFA; (85kW)	03.04-05.06		incl. ; incl. ; SAC		600 0024 00
			SAC		625 3022 00
					415 0180 10
					411 0120 10
					512 0359 10
			A/C		529 0389 10
			A/C		529 0390 10
					532 0449 10
					534 0031 10
			F# F-237045.XX		535 0087 10
			F# F-563432.XX		535 0159 10
			# 920583		535 0314 10
			A/C; # OE 1129181		FB 7PK2710
			A/C		FB 7PK2875

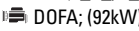

			<p>SCHAEFFLER</p>
--	--	--	--------------------------

FORD

TRANSIT V (F_)

















































































































<p>2.4 TDE  FXFA; (85kW)</p>	<p>03.04-05.06</p>	<p> FAG</p>	<p>1x  538 0262 10  558 0055 10  559 0152 10  559 0152 30  right  left  713 0390 20  Set 713 6786 50  Set 713 6784 20  771 0600 30  814 0052 10  814 0052 10  FWD ;  BM 260, 280, 300  RWD  FWD ;  BM 330, 350  818 0318 10  818 0152 10  825 0104 10  LHD  RHD  LHD  RHD</p>	<p>840 0134 10 840 0284 10 840 0775 10 600 0023 00 600 0024 00 625 3015 00 625 3022 00 415 0180 10 411 0120 10 512 0359 10 529 0389 10 529 0390 10 532 0449 10 534 0031 10 535 0087 10 535 0159 10 535 0314 10 FB 7PK2710 FB 7PK2875 538 0262 10  558 0055 10  559 0152 10  559 0152 30  559 0176 10  559 0176 30  right  left  713 0390 20  Set 713 6786 50  Set 713 6784 20  771 0600 30  814 0052 10  FWD ;  BM 260, 280, 300  RWD  FWD ;  BM 330, 350  818 0318 10  818 0152 10  825 0104 10  LHD  RHD  LHD  RHD 840 0134 10 840 0284 10 840 0775 10 600 0023 00</p>
<p>2.4 TDE  DOFA; (92kW)</p>	<p>07.01-05.06</p>	<p>  FAG</p>	<p>→04.02 incl.  ; incl.  ; SAC 05.02→ incl.  ; incl.  ; SAC →04.02;  415 0180 10 SAC 05.02→ SAC 415 0180 10 411 0120 10 04.02→  A/C  A/C  A/C  A/C  F-237045.XX  F-563432.XX  920583  OE 1129181  A/C  A/C 538 0262 10  558 0055 10  559 0152 10  559 0152 30  559 0176 10  559 0176 30  right  left  713 0390 20  Set 713 6786 50  Set 713 6784 20  771 0600 30  814 0052 10  FWD ;  BM 260, 280, 300  RWD  FWD ;  BM 330, 350  818 0318 10  818 0152 10  825 0104 10  LHD  RHD  LHD  RHD 840 0134 10 840 0284 10 840 0775 10 600 0023 00</p>	<p>600 0023 00 600 0024 00 625 3015 00 625 3022 00 415 0180 10 411 0120 10 512 0359 10 529 0389 10 529 0390 10 532 0449 10 534 0031 10 535 0087 10 535 0159 10 535 0314 10 FB 7PK2710 FB 7PK2875 538 0262 10  558 0055 10  559 0152 10  559 0152 30  559 0176 10  559 0176 30  right  left  713 0390 20  Set 713 6786 50  Set 713 6784 20  771 0600 30  814 0052 10  FWD ;  BM 260, 280, 300  RWD  FWD ;  BM 330, 350  818 0318 10  818 0152 10  825 0104 10  LHD  RHD  LHD  RHD 840 0134 10 840 0284 10 840 0775 10 600 0023 00</p>
<p>2.4 TDE (F_C_, F_B_, F_A_)  DOFA; (92kW)</p>	<p>07.01-05.06</p>	<p></p>	<p>→04.02 incl.  ; incl.  ; SAC</p>	<p>600 0023 00</p>



			SCHAEFFLER
--	--	--	-------------------

FORD

TRANSIT V (F_)









































2.4 TDE (F_C_, F_B_, F_A_)  DOFA; (92kW)	07.01-05.06		05.02→ incl. ☉; incl.  ; SAC		600 0024 00	
			→04.02;  415 0180 10		625 3015 00	
			SAC		625 3022 00	
			05.02→ SAC		415 0180 10	
					411 0120 10	
			04.02→		512 0359 10	
			 ; A/C		529 0389 10	
			 ; A/C		529 0390 10	
					532 0449 10	
					534 0031 10	
			 # F-237045.XX		535 0087 10	
			 # F-563432.XX		535 0159 10	
			 # 920583		535 0314 10	
			 ; A/C; # OE 1129181		FB 7PK2710	
			 A/C		FB 7PK2875	
					538 0262 10	
			1x		558 0055 10	
			1x; 03.04→		559 0152 10	
			1x; 03.04→		559 0152 30	
			1x; →03.04		559 0176 10	
			1x; →03.04		559 0176 30	
		FAG	 right		821 0264 10	
			 left		821 0263 10	
					713 0390 20	
					713 6786 50	
					713 6784 20	
					771 0600 30	
					814 0052 10	
			 ; FWD;  BM 260, 280, 300		818 0304 10	
			 ; RWD			
			 ; FWD;  BM 330, 350		818 0318 10	
					818 0152 10	
			 ; LHD		825 0104 10	
			 ; RHD		840 0134 10	
			 ; LHD		840 0284 10	
			 ; RHD			
					840 0775 10	
2.4 TDCi  H9FA; (101kW)	03.04-05.06		G6;  MT82	GearBOX	462 0204 10	
			G6; 		600 0173 00	
			incl. ☉; incl.  ; SAC		626 3034 33	
			G6; 		626 3053 09	
			SAC			
			G6;  ;  ;  HPCR;  ;  TR		626 3053 33	
			SAC			
			G6;  ;  ;  HPCR;  ;  TR		415 0388 10	
			G6		411 0120 10	
			G6; 		529 0389 10	
			 ; A/C		529 0390 10	
			 ; A/C		532 0449 10	
					534 0031 10	
			 # F-237045.XX		535 0087 10	
			 # F-563432.XX		535 0159 10	
			 # 920583		535 0314 10	
			 ; A/C; # OE 1129181		FB 7PK2710	
			 A/C		FB 7PK2875	
					538 0262 10	
			1x		558 0055 10	
			1x		559 0152 10	
			1x		559 0152 30	
		FAG	 right		821 0264 10	













































































































			<p>SCHAEFFLER</p>
--	--	--	--------------------------

FORD

TRANSIT V (F_)

<p>2.4 TDCi  H9FA; (101kW)</p>	<p>03.04-05.06</p>	<p>FAG</p>	<p> left</p> <p> </p> <p> ;  </p> <p> ; </p> <p> ; </p> <p> ; </p> <p> ; FWD ;  BM 260, 280, 300</p> <p> ; RWD</p> <p> ; FWD ;  BM 330, 350</p> <p></p> <p></p> <p> ; LHD</p> <p> ; RHD</p> <p> ; LHD</p> <p> ; RHD</p> <p></p>	<p> 821 0263 10</p> <p> 713 0390 20</p> <p>  Set 713 6786 50</p> <p>  Set 713 6784 20</p> <p> 771 0600 30</p> <p> 814 0052 10</p> <p> 814 0052 10</p> <p> 818 0304 10</p> <p> 818 0318 10</p> <p> 818 0152 10</p> <p> 825 0104 10</p> <p> 840 0134 10</p> <p> 840 0284 10</p> <p> 840 0775 10</p>
--	--------------------	-------------------	---	---

TRANSIT VI / TRANSIT TOURNEO

















































































































































<p>2.2 TDCi  P8FA; P8FB; (63kW)</p>	<p>04.06-08.14</p>	<p>LUK</p> <p></p>	<p>SAC</p> <p> ; A/C</p> <p> ; A/C</p> <p></p> <p></p> <p> # 370V1-1 F-556174.XX</p> <p> # F-554766.XX</p> <p> ; FWD</p> <p></p> <p> ; FWD ; A/C</p> <p> ; A/C</p> <p>1x  558 0062 10</p> <p>1x  558 0063 10</p> <p>1x  558 0066 10</p> <p>1x  559 0193 10</p> <p>1x  559 0193 30</p> <p> right; </p> <p> left; </p> <p> ;  → 1.750 kg</p> <p> ;  ;  → 1.850 kg</p> <p> ;  260; 280; 300</p> <p> ;  330; 350</p> <p> ; </p> <p></p> <p></p> <p> ;  → 1.750 kg</p> <p> ;  1.751 kg →</p> <p> ; LHD</p> <p> ; RHD</p> <p> ; LHD</p> <p> ; RHD</p>	<p> 625 3044 33</p> <p>  529 0301 10</p> <p>  529 0301 30</p> <p> 532 0470 10</p> <p> 532 0477 10</p> <p> 535 0128 10</p> <p> 535 0160 10</p> <p> FB 4EPK922</p> <p> FB 4EPK922</p> <p> FB 6EPK873</p> <p> FB 6EPK873</p> <p> 538 0465 10</p> <p> 558 0062 10</p> <p> 558 0063 10</p> <p> 558 0066 10</p> <p> 559 0193 10</p> <p> 559 0193 30</p> <p> 821 0264 10</p> <p> 821 0263 10</p> <p>  713 6789 00</p> <p>  713 6789 10</p> <p>  713 6789 20</p> <p>  713 6789 30</p> <p> 771 0562 30</p> <p> 814 0162 10</p> <p> 818 0318 10</p> <p> 818 0152 10</p> <p> 825 0104 10</p> <p> 825 0273 10</p> <p> 840 0134 10</p> <p> 840 0284 10</p> <p> 840 0775 10</p>
<p>2.2 TDCi  DRFA; DRFB; DRFC; DRFD; DRFE; (74kW)</p>	<p>10.11-08.14</p>	<p>LUK</p> <p></p>	<p>incl.  ; SAC</p> <p>SAC</p> <p> ;  ; FWD ; A/C START/STOP</p> <p> ; 4WD RWD ; A/C</p> <p> ; FWD ; →12.13; A/C</p> <p> ; FWD ; A/C START/STOP</p> <p> ; RWD 4WD ; A/C</p> <p></p> <p> ; FWD ; →12.13; A/C</p> <p> ; FWD ; A/C</p> <p> ; RWD 4WD ; A/C</p> <p> ; RWD 4WD ; A/C</p>	<p> 600 0315 00</p> <p> 626 3093 33</p> <p> 415 0562 10</p> <p> 411 0120 10</p> <p> 529 0322 10</p> <p> 529 0442 10</p> <p> 532 0470 10</p> <p> 532 0477 10</p> <p> 532 0909 10</p> <p> 532 0910 10</p> <p> 534 0308 10</p> <p> 534 0308 10</p> <p> 534 0682 10</p>



			SCHAEFFLER
--	---	--	-------------------

FORD

TRANSIT VI / TRANSIT TOURNEO











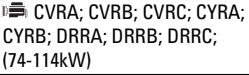











































































































































































<p>2.2 TDCi  DRFA; DRFB; DRFC; DRFD; DRFE; (74kW)</p>	<p>10.11-08.14</p>		 # 370V1-1 F-556174.XX	 535 0128 10	
			 # F-554766.XX	 535 0160 10	
			 ; FWD	 FB 4EPK922	
			 ; FWD ; A/C	 FB 6EPK873	
			 ; FWD ; A/C	 FB 6PK1640	
			 ; A/C	 FB 6PK1670	
				 538 0465 10	
			1x		
			FAG		
			 right; 	 821 0264 10	
		 left; 	 821 0263 10		
		 ;  → 1.750 kg	 Set 713 6789 00		
		 ;  ;  → 1.850 kg	 Set 713 6789 10		
		 ;  260; 280; 300	 Set 713 6789 20		
			 Set 713 6789 30		
		 ;  330; 350	 Set 713 6789 30		
			 814 0162 10		
			 818 0318 10		
			 818 0152 10		
		 ;  → 1.750 kg	 825 0104 10		
 ;  1.751 kg →	 825 0273 10				
 ; LHD	 840 0134 10				
 ; RHD					
 ; LHD	 840 0284 10				
 ; RHD					
	 840 0775 10				
<p>2.2 TDCi RWD  CVRA; CVRB; CVRC; CYRA; CYRB; DRRR; DRRB; DRRC; (74-114kW)</p>	<p>09.11-12.14</p>		G6 ;  MT82	GearBOX 462 0211 10	
			incl.  ; incl.  ; SAC	 600 0262 00	
				 627 3032 35	
				 627 3040 33	
				 415 0628 10	
				 411 0120 10	
				 ; FWD ; A/C START/STOP	 529 0322 10
			 ; 4WD RWD ; A/C	 529 0442 10	
			 ; FWD ; A/C	 532 0470 10	
			 ; FWD ; A/C START/STOP	 532 0477 10	
		 ; RWD 4WD ; A/C	 532 0909 10		
			 532 0910 10		
		 ; FWD ; A/C	  534 0308 10		
		 ; RWD 4WD ; A/C	  534 0682 10		
		 ; RWD 4WD ; A/C			
		 # 370V1-1 F-556174.XX	 535 0128 10		
		 ; FWD	 FB 4EPK922		
		 ; FWD ; A/C	 FB 6EPK873		
		 ; FWD ; A/C	 FB 6PK1640		
		 ; A/C	 FB 6PK1670		
	 538 0465 10				
1x					
FAG					
 right; 	 821 0264 10				
 left; 	 821 0263 10				
 ;  → 1.750 kg	 Set 713 6789 00				
 ;  ;  → 1.850 kg	 Set 713 6789 10				
 right; 	 Set 713 6791 10				
					
 left; 	 Set 713 6791 00				
					
	 814 0162 10				
	 818 0318 10				
	 818 0152 10				
 ;  → 1.750 kg	 825 0104 10				
 ;  1.751 kg →	 825 0273 10				
 ; LHD	 840 0134 10				
 ; RHD					
 ; LHD	 840 0284 10				
 ; RHD					



			<p>SCHAEFFLER</p>
--	---	--	--------------------------

FORD

TRANSIT VI / TRANSIT TOURNEO







































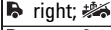

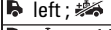

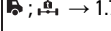





































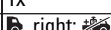

<p>2.2 TDCi RWD  CVRA; CVRB; CVRC; CYRA; CYRB; DRA; DRRB; DRRC; (74-114kW)</p>	<p>09.11-12.14</p>	<p>FAG</p>	<p> </p>	<p> 840 0775 10</p>
<p>2.2 TDCi  QVFA; (81kW)</p>	<p>04.06-08.14</p>	<p>LUK </p>	<p>SAC  ; A/C  ; A/C    ; 09.11 →  # 370V1-1 F-556174.XX  # F-554766.XX  ; FWD  ; FWD ; A/C  ; A/C 1x  558 0062 10 1x  558 0063 10 1x  558 0066 10 1x  559 0193 10 1x  559 0193 30 FAG  right;   left;   ;  → 1.750 kg  ;  ;  → 1.850 kg  ;  260; 280; 300  ;  330; 350  ;      ;  → 1.750 kg  ;  1.751 kg →  ; LHD  ; RHD  ; LHD  ; RHD</p>	<p> 625 3044 33  529 0301 10  529 0301 30  532 0470 10  532 0477 10  532 0910 10  535 0128 10  535 0160 10  FB 4EPK922  FB 6EPK873  FB 6EPK873  538 0465 10  558 0062 10  558 0063 10  558 0066 10  559 0193 10  559 0193 30  821 0264 10  821 0263 10   713 6789 00   713 6789 10   713 6789 20   713 6789 30  771 0562 30  814 0162 10  818 0318 10  818 0152 10  825 0104 10  825 0273 10  840 0134 10  840 0284 10  840 0775 10  625 3044 33  529 0301 10  529 0301 30  532 0470 10  532 0477 10  532 0910 10  535 0128 10  FB 4EPK922  FB 6EPK873  538 0465 10  558 0062 10  558 0063 10  558 0066 10  559 0193 10  559 0193 30  821 0264 10  821 0263 10   713 6789 00   713 6789 10   713 6789 20   713 6789 30  814 0162 10  818 0318 10  818 0152 10  825 0104 10  825 0273 10  840 0134 10</p>
<p>2.2 TDCi  QVFA; (81kW)</p>	<p>07.06-08.14</p>	<p>LUK </p>	<p>SAC  ; A/C  ; A/C    ; 09.11 →  # 370V1-1 F-556174.XX  ; FWD  ; FWD ; A/C 1x  558 0062 10 1x  558 0063 10 1x  558 0066 10 1x  559 0193 10 1x  559 0193 30 FAG  right;   left;   ;  → 1.750 kg  ;  ;  → 1.850 kg  ;  260; 280; 300  ;  330; 350     ;  → 1.750 kg  ;  1.751 kg →  ; LHD  ; RHD</p>	<p> 840 0775 10  625 3044 33  529 0301 10  529 0301 30  532 0470 10  532 0477 10  532 0910 10  535 0128 10  FB 4EPK922  FB 6EPK873  538 0465 10  558 0062 10  558 0063 10  558 0066 10  559 0193 10  559 0193 30  821 0264 10  821 0263 10   713 6789 00   713 6789 10   713 6789 20   713 6789 30  814 0162 10  818 0318 10  818 0152 10  825 0104 10  825 0273 10  840 0134 10</p>

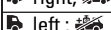

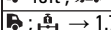
			SCHAEFFLER
--	---	--	-------------------

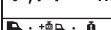
FORD

TRANSIT VI / TRANSIT TOURNEO













































































































































2.2 TDCi CVFA; (81kW)	07.06-08.14	FAG	 ; LHD		840 0284 10	
			 ; RHD		840 0284 10	
2.2 TDCi SRFA; SRFB; SRFC; SRFD; SRFE; (85kW)	10.08-08.14	LUK	SAC		840 0775 10	
				625 3061 33		
				415 0438 10		
				411 0120 10		
				529 0301 10		
				529 0301 30		
				532 0470 10		
				532 0477 10		
				532 0910 10		
				535 0128 10		
				535 0160 10		
				FB 4EPK922		
				FB 6EPK873		
				538 0465 10		
			1x 		558 0062 10	
			1x 		558 0063 10	
			1x 		558 0066 10	
			1x 		559 0193 10	
			1x 		559 0193 30	
			FAG			821 0264 10
						821 0263 10
						713 6789 00
						713 6789 10
						713 6789 20
						713 6789 30
					814 0162 10	
					818 0318 10	
					818 0152 10	
	825 0104 10					
	825 0273 10					
	840 0134 10					
	840 0284 10					
	840 0775 10					
2.2 TDCi CYFA; CYFB; CYFC; CYFD; (92kW)	10.11-08.14	LUK		incl. O; SAC		600 0315 00
				SAC		626 3093 33
				415 0562 10		
				411 0120 10		
				529 0322 10		
				529 0442 10		
				532 0470 10		
				532 0477 10		
				532 0909 10		
				532 0910 10		
				534 0308 10		
				534 0682 10		
				535 0128 10		
				535 0160 10		
				FB 4EPK922		
				FB 6EPK873		
				FB 6PK1640		
				FB 6PK1670		
				538 0465 10		
			1x 		558 0062 10	
			FAG			821 0264 10
						821 0263 10
		713 6789 00				
		713 6789 10				
		713 6789 20				
		713 6789 30				
	713 6789 30					
	713 6789 30					



			<p>SCHAEFFLER</p>
--	--	--	--------------------------

FORD

TRANSIT VI / TRANSIT TOURNEO













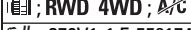

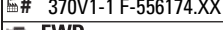











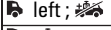

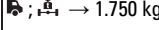











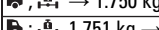





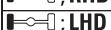
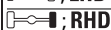

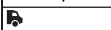

















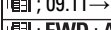



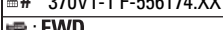











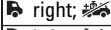

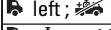

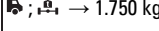

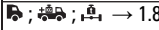















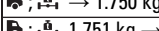

<p>2.2 TDCi CYFA; CYFB; CYFC; CYFD; (92kW)</p>	<p>10.11-08.14</p>	<p>FAG</p>	<p>    → 1.750 kg  → 1.751 kg →  ; LHD  ; RHD  ; LHD  ; RHD</p>	<p> 814 0162 10  818 0318 10  818 0152 10  825 0104 10  825 0273 10  840 0134 10  840 0284 10  840 0775 10</p>
<p>2.2 TDCi 4x4 CYRB; CYRC; (92kW)</p>	<p>10.11-08.14</p>	<p>LUK</p>	<p>incl. ; incl. ; SAC  SAC  SAC  415 0628 10  411 0120 10   ; FWD ; A/C START/STOP  ; 4WD RWD ; A/C  ; FWD ; A/C  ; FWD ; A/C START/STOP  ; RWD 4WD ; A/C   ; FWD ; A/C  ; RWD 4WD ; A/C  ; RWD 4WD ; A/C # 370V1-1 F-556174.XX  ; FWD  ; FWD ; A/C  ; FWD ; A/C  ; A/C  538 0465 10 1x   558 0062 10  right;   left;   ;  → 1.750 kg  ;  ;  → 1.850 kg  right;    left;        → 1.750 kg  → 1.751 kg →  ; LHD  ; RHD  ; LHD  ; RHD</p>	<p> 600 0262 00  627 3032 35  627 3040 33  415 0628 10  411 0120 10  529 0322 10  529 0442 10  532 0470 10  532 0477 10  532 0909 10  532 0910 10  534 0308 10  534 0682 10  535 0128 10  FB 4EPK922  FB 6EPK873  FB 6PK1640  FB 6PK1670  538 0465 10   558 0062 10  821 0264 10  821 0263 10  713 6789 00  713 6789 10  713 6791 10  713 6791 00  814 0162 10  818 0318 10  818 0152 10  825 0104 10  825 0273 10  840 0134 10  840 0284 10  840 0775 10 GearBOX  462 0211 10  600 0262 00  627 3032 35  627 3040 33  415 0628 10  411 0120 10  529 0322 10  529 0442 10  532 0470 10  532 0477 10  532 0909 10  532 0910 10 534 0308 10</p>
<p>2.2 TDCi RWD CYRA; CYRB; (92kW)</p>	<p>10.11-08.14</p>	<p>LUK</p>	<p>G6 ;  MT82 incl. ; incl. ; SAC  SAC  SAC  415 0628 10  411 0120 10   ; FWD ; A/C START/STOP  ; 4WD RWD ; A/C  ; FWD ; A/C  ; FWD ; A/C START/STOP  ; RWD 4WD ; A/C   ; FWD ; A/C</p>	<p> 462 0211 10  600 0262 00  627 3032 35  627 3040 33  415 0628 10  411 0120 10  529 0322 10  529 0442 10  532 0470 10  532 0477 10  532 0909 10  532 0910 10  534 0308 10</p>

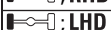

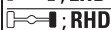
			SCHAEFFLER
--	---	--	-------------------

FORD

TRANSIT VI / TRANSIT TOURNEO



























































































































































































2.2 TDCi RWD CYRA; CYRB; (92kW)	10.11-08.14		 ; RWD 4WD ; A/C	 534 0682 10	
			 ; RWD 4WD ; A/C	 535 0128 10	
			 # 370V1-1 F-556174.XX	 538 0465 10	
			 ; FWD	 538 0465 10	
			 ; FWD ; A/C	 538 0465 10	
			 ; FWD ; A/C	 538 0465 10	
			 ; A/C	 538 0465 10	
			1x	 538 0465 10	
			FAG	 right;	 821 0264 10
				 left;	 821 0263 10
		 ; → 1.750 kg		 713 6789 00	
		 right;		 713 6791 10	
		 left;		 713 6791 00	
				 814 0162 10	
				 818 0318 10	
				 818 0152 10	
		 ; → 1.750 kg		 825 0104 10	
		 ; → 1.751 kg		 825 0273 10	
		 ; LHD	 840 0134 10		
		 ; RHD			
 ; LHD	 840 0284 10				
 ; RHD					
	 840 0775 10				
2.2 TDCi QWFA; (96kW)	04.06-08.14		SAC	 624 3307 09	
			 VXT75	 624 3307 33	
			SAC		
				 415 0415 10	
				 411 0120 10	
			 ; A/C	 529 0301 10	
			 ; A/C	 529 0301 30	
				 532 0470 10	
				 532 0477 10	
			 ; 09.11 →	 532 0910 10	
			 ; FWD ; A/C	 534 0308 10	
			 # 370V1-1 F-556174.XX	 535 0128 10	
			 ; FWD	 535 0128 10	
			 ; FWD ; A/C	 535 0128 10	
				 538 0465 10	
		1x	 558 0062 10		
		1x	 558 0063 10		
		1x	 558 0066 10		
		1x	 559 0193 10		
		1x	 559 0193 30		
FAG	 right;	 821 0264 10			
	 left;	 821 0263 10			
	 ; → 1.750 kg	 713 6789 00			
	 ; → 1.850 kg	 713 6789 10			
	 ; 260; 280; 300	 713 6789 20			
	 ; 330; 350	 713 6789 30			
		 771 0562 30			
		 814 0162 10			
		 818 0318 10			
		 818 0152 10			
 ; → 1.750 kg	 825 0104 10				
 ; → 1.751 kg	 825 0273 10				
 ; LHD	 840 0134 10				
 ; RHD					
 ; LHD	 840 0284 10				
 ; RHD					
	 840 0775 10				
2.2 TDCi QWFA; (96kW)	07.06-08.14		SAC	 624 3307 09	
			 VXT75	 624 3307 33	



			<p>SCHAEFFLER</p>
--	--	--	--------------------------

FORD

TRANSIT VI / TRANSIT TOURNEO



































































































<p>2.2 TDCi  QWFA; (96kW)</p>	<p>07.06-08.14</p>	<p></p>	<p> 415 0415 10</p> <p> 411 0120 10</p> <p> 529 0301 10</p> <p> 529 0301 30</p> <p> 532 0470 10</p> <p> 532 0477 10</p> <p> 532 0910 10</p> <p> 535 0128 10</p> <p> FB 4EPK922</p> <p> FB 6EPK873</p> <p> 538 0465 10</p> <p>  558 0062 10</p> <p>  558 0063 10</p> <p>  558 0066 10</p> <p>  559 0193 10</p> <p>  559 0193 30</p> <p>  right;  821 0264 10</p> <p>  left;  821 0263 10</p> <p>  713 6789 00</p> <p>  713 6789 10</p> <p>  713 6789 20</p> <p>  713 6789 30</p> <p> 814 0162 10</p> <p> 818 0318 10</p> <p> 818 0152 10</p> <p>  → 1.750 kg 825 0104 10</p> <p>  1.751 kg → 825 0273 10</p> <p>  LHD 840 0134 10</p> <p>  RHD</p> <p>  LHD 840 0284 10</p> <p>  RHD</p> <p> 840 0775 10</p>	<p> 415 0415 10</p> <p> 411 0120 10</p> <p> 529 0301 10</p> <p> 529 0301 30</p> <p> 532 0470 10</p> <p> 532 0477 10</p> <p> 532 0910 10</p> <p> 535 0128 10</p> <p> FB 4EPK922</p> <p> FB 6EPK873</p> <p> 538 0465 10</p> <p>  558 0062 10</p> <p>  558 0063 10</p> <p>  558 0066 10</p> <p>  559 0193 10</p> <p>  559 0193 30</p> <p>  right;  821 0264 10</p> <p>  left;  821 0263 10</p> <p>  713 6789 00</p> <p>  713 6789 10</p> <p>  713 6789 20</p> <p>  713 6789 30</p> <p> 814 0162 10</p> <p> 818 0318 10</p> <p> 818 0152 10</p> <p>  → 1.750 kg 825 0104 10</p> <p>  1.751 kg → 825 0273 10</p> <p>  LHD 840 0134 10</p> <p>  RHD</p> <p>  LHD 840 0284 10</p> <p>  RHD</p> <p> 840 0775 10</p>
<p>2.2 TDCi RWD  USRA; USRB; (100kW)</p>	<p>09.11-08.14</p>	<p></p>	<p> GearBOX 462 0211 10</p> <p> 600 0262 00</p> <p> 627 3032 35</p> <p> 627 3040 33</p> <p> 415 0628 10</p> <p> 411 0120 10</p> <p>  529 0322 10</p> <p>  529 0442 10</p> <p> 532 0470 10</p> <p> 532 0477 10</p> <p> 532 0909 10</p> <p> 534 0308 10</p> <p> 534 0682 10</p> <p> 535 0128 10</p> <p> FB 4EPK922</p> <p> FB 6EPK873</p> <p> FB 6PK1640</p> <p> FB 6PK1670</p> <p> 538 0465 10</p> <p>  558 0062 10</p> <p>  right;  821 0264 10</p> <p>  left;  821 0263 10</p> <p>  713 6789 00</p> <p>  713 6789 10</p> <p>  713 6791 10</p> <p>  713 6791 00</p> <p> 814 0162 10</p> <p> 818 0318 10</p> <p> 818 0152 10</p>	<p> GearBOX 462 0211 10</p> <p> 600 0262 00</p> <p> 627 3032 35</p> <p> 627 3040 33</p> <p> 415 0628 10</p> <p> 411 0120 10</p> <p>  529 0322 10</p> <p>  529 0442 10</p> <p> 532 0470 10</p> <p> 532 0477 10</p> <p> 532 0909 10</p> <p> 534 0308 10</p> <p> 534 0682 10</p> <p> 535 0128 10</p> <p> FB 4EPK922</p> <p> FB 6EPK873</p> <p> FB 6PK1640</p> <p> FB 6PK1670</p> <p> 538 0465 10</p> <p>  558 0062 10</p> <p>  right;  821 0264 10</p> <p>  left;  821 0263 10</p> <p>  713 6789 00</p> <p>  713 6789 10</p> <p>  713 6791 10</p> <p>  713 6791 00</p> <p> 814 0162 10</p> <p> 818 0318 10</p> <p> 818 0152 10</p>



			SCHAEFFLER
--	---	--	-------------------

FORD

TRANSIT VI / TRANSIT TOURNEO

2.2 TDCi RWD USRA; USRB; (100kW)	09.11-08.14	FAG	 ;  → 1.750 kg	 825 0104 10
			 ;  1.751 kg →	 825 0273 10
			 ; LHD	 840 0134 10
			 ; RHD	
			 ; LHD	 840 0284 10
			 ; RHD	
				 840 0775 10
				GearBOX 462 0211 10
				 600 0262 00
				 627 3032 35
	 627 3040 33			
	 415 0628 10			
	 411 0120 10			
2.2 TDCi RWD USRA; USRB; (100kW)	10.11-08.14	LUK	G6 ;  MT82	 529 0322 10
			incl.  ; incl.  ; SAC	 600 0262 00
			 SAC	 627 3032 35
			 SAC	 627 3040 33
				 415 0628 10
				 411 0120 10
				 529 0322 10
				 529 0442 10
				 532 0470 10
				 532 0477 10
			 532 0909 10	
			 534 0308 10	
			 FB 4EPK922	
			 FB 6EPK873	
			 FB 6PK1640	
			 FB 6PK1670	
			 558 0062 10	
			 821 0264 10	
			 821 0263 10	
		2.2 TDCi PGFA; PGFB; UHFA; UHFB; UHFC; (103kW)	10.07-09.11	FAG
 left; 	 821 0263 10			
 ;  → 1.750 kg	 Set 713 6789 00			
 ;  → 1.850 kg	 Set 713 6789 10			
 right; 	 Set 713 6791 10			
 left; 	 Set 713 6791 00			
	 814 0162 10			
	 818 0152 10			
 ;  → 1.750 kg	 825 0104 10			
 ;  1.751 kg →	 825 0273 10			
	 840 0134 10			
	 840 0284 10			
	 840 0775 10			
	 625 3061 33			
	 415 0438 10			
	 411 0120 10			
	 529 0301 10			
	 529 0322 10			
	 529 0442 10			
	 529 0301 30			
	 532 0470 10			
	 532 0477 10			
	 532 0909 10			
	 532 0910 10			
	 534 0308 10			
	 535 0128 10			
	 FB 4EPK922			
	 FB 6EPK873			
	 FB 6PK1640			
	 538 0465 10			
	 558 0062 10			
	 558 0063 10			
	 558 0066 10			
	 559 0193 10			
	 559 0193 30			
	FAG			
	 right; 	 821 0264 10		
	 left; 	 821 0263 10		



			SCHAEFFLER
--	--	--	-------------------

FORD

TRANSIT VI / TRANSIT TOURNEO

































































































































2.2 TDCi PGFA; PGFB; UHFA; UHFB; UHFC; (103kW)	10.07-09.11	FAG	; → 1.750 kg	Set	713 6789 00
			; ; → 1.850 kg	Set	713 6789 10
			; 260; 280; 300	Set	713 6789 20
			; 330; 350	Set	713 6789 30
					814 0162 10
					818 0318 10
					818 0152 10
			; → 1.750 kg		825 0104 10
			; 1.751 kg →		825 0273 10
			; LHD		840 0134 10
			; RHD		
			; LHD		840 0284 10
			; RHD		
					840 0775 10
			2.2 TDCi PGFA; PGFB; UHFA; UHFB; UHFC; (103kW)	10.07-08.14	LUK
→09.11; PUMA SAC		625 3061 33			
10.11→; PUMA SAC		626 3093 33			
→09.11; PUMA		415 0438 10			
10.11→; PUMA		415 0562 10			
					411 0120 10
	; A/C				529 0301 10
	; UHFA UHFB UHFC; FWD ; A/C START/STOP				529 0322 10
	; UHFA UHFB UHFC; 4WD RWD ; A/C				529 0442 10
	; A/C				529 0301 30
	; FWD ; A/C				532 0470 10
					532 0470 10
	; FWD ; A/C START/STOP				532 0477 10
	; UHFA UHFB UHFC; RWD 4WD ; A/C				532 0909 10
	; 09.11→				532 0910 10
	; FWD ; A/C				534 0308 10
					534 0308 10
	# 370V1-1 F-556174.XX				535 0128 10
	; FWD				FB 4EPK922
	; FWD ; A/C				FB 6EPK873
	; FWD ; A/C				FB 6PK1640
					538 0465 10
1x		558 0062 10			
1x		558 0063 10			
1x		558 0066 10			
1x		559 0193 10			
1x		559 0193 30			
FAG	right;		821 0264 10		
	left;		821 0263 10		
	; → 1.750 kg	Set	713 6789 00		
	; ; → 1.850 kg	Set	713 6789 10		
	; 260; 280; 300	Set	713 6789 20		
	; 330; 350	Set	713 6789 30		
			814 0162 10		
			818 0318 10		
			818 0152 10		
	; → 1.750 kg		825 0104 10		
	; 1.751 kg →		825 0273 10		
	; LHD		840 0134 10		
	; RHD				
	; LHD		840 0284 10		
	; RHD				
		840 0775 10			
2.3 16V CNG RWD 2.3 16V LPG RWD GZFC; (100-107kW)	04.06-08.14		; A/C		529 0397 10
					532 0651 10
					534 0128 20
			; A/C		FB 6PK2280
			right;		821 0264 10
left;		821 0263 10			



			SCHAEFFLER
--	---	--	-------------------

FORD

TRANSIT VI / TRANSIT TOURNEO















































































































2.3 16V CNG RWD 2.3 16V LPG RWD GZFC; (100-107kW)	04.06-08.14	FAG	 ;  → 1.750 kg	 Set	713 6789 00
			 ;  ;  → 1.850 kg	 Set	713 6789 10
			 right; 	 Set	713 6791 10
			 left; 	 Set	713 6791 00
					814 0162 10
					818 0152 10
			 ;  → 1.750 kg		825 0104 10
			 ;  1.751 kg →		825 0273 10
			 ; LHD		840 0134 10
			 ; RHD		
			 ; LHD		840 0284 10
			 ; RHD		
					840 0775 10
			→08.07 SAK		625 3011 00
			09.07 → SAK		625 3044 00
2.3 16V RWD GZFA; GZFB; GZFC; (107kW)	04.06-08.14		 ; A/C		529 0397 10
					532 0651 10
					534 0128 20
		 ; A/C		FB 6PK2280	
		FAG	 right; 		821 0264 10
			 left; 		821 0263 10
			 ;  → 1.750 kg	 Set	713 6789 00
			 ;  ;  → 1.850 kg	 Set	713 6789 10
			 right; 	 Set	713 6791 10
			 left; 	 Set	713 6791 00
					814 0162 10
					818 0318 10
					818 0152 10
			 ;  → 1.750 kg		825 0104 10
			 ;  1.751 kg →		825 0273 10
 ; LHD			840 0134 10		
 ; RHD					
 ; LHD		840 0284 10			
 ; RHD					
		840 0775 10			
2.4 TDCi PHFA; PHFC; (74kW)	04.06-08.14	LUK	→07.07; G6;  MT82	GearBOX	462 0204 10
			08.07 →; G6;  MT82	GearBOX	462 0211 10
			G6;  HPCR		600 0173 00
			incl.  ; incl.  ; SAC		
			G5;  HPCR		600 0186 00
			incl.  ; incl.  ; SAC		
			G5;  HPCR; 		625 3044 00
			SAC		
			G5;  HPCR		625 3068 00
			SAC		
			G6;  HPCR		626 3034 33
			SAC		
		G6;  HPCR; 		626 3053 33	
		SAC			
		G6;  HPCR		415 0388 10	
G5;  HPCR		415 0438 10			
 HPCR		411 0120 10			
		512 0359 10			
	 ; A/C		529 0364 10		
	 ; A/C; # OE 1129181		529 0388 10		
	 ; A/C		529 0364 30		
	 ; A/C; # OE 1129181		529 0388 30		
	 ;  BM Transit 330		532 0776 10		
 ;  BM Transit 350					
 ;  BM Transit 370					
 ;  BM Transit 430					



			<p>SCHAEFFLER</p>
--	--	--	--------------------------

FORD

TRANSIT VI / TRANSIT TOURNEO





















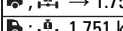







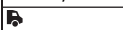

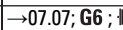
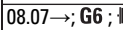

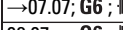
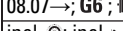
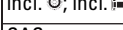





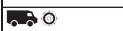

















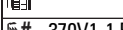
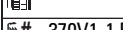

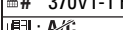

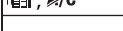



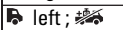
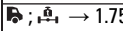

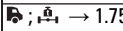

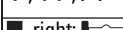



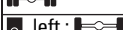

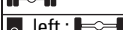









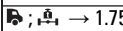

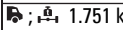







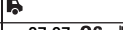

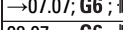
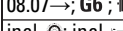

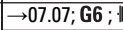
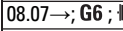







<p>2.4 TDCi PHFA; PHFC; (74kW)</p>	<p>04.06-08.14</p>	<p></p>	<p> ;  # 370V1-1 F-556174.XX  ; A/C ; # OE 1376751  ; A/C ; # OE 1129182 1x 1x right;  left;  ;  → 1.750 kg ;  ;  → 1.850 kg right;   left;   ;  → 1.750 kg ;  1.751 kg → ; LHD ; RHD ; LHD ; RHD ;</p>	<p> 534 0434 10  535 0128 10  FB 7PK2683  FB 7PK2875  538 0262 10  558 0062 10  559 0184 10  821 0264 10  821 0263 10  713 6789 00  713 6789 10  713 6791 10  713 6791 00  814 0162 10  818 0318 10  818 0152 10  825 0104 10  825 0273 10  840 0134 10  840 0284 10  840 0775 10</p>
<p>2.4 TDCi RWD PHFA; PHFC; (74kW)</p>	<p>04.06-08.14</p>	<p></p>	<p>→07.07; G6 ;  MT82 08.07→; G6 ;  MT82 G6 ;  HPCR incl.  ; incl.  SAC G5 ;  HPCR incl.  ; incl.  SAC G5 ;  HPCR;  SAC G5 ;  HPCR SAC G6 ;  HPCR SAC G6 ;  HPCR;  SAC G6 ;  HPCR G5 ;  HPCR  HPCR</p>	<p> 462 0204 10  462 0211 10  600 0173 00  600 0186 00  625 3044 00  625 3068 00  626 3034 33  626 3053 33  415 0388 10  415 0438 10  411 0120 10  512 0359 10  529 0364 10  529 0388 10  529 0364 30  529 0388 30  532 0776 10</p>
		<p></p>	<p> ; A/C  ; A/C ; # OE 1129181  ; A/C  ; A/C ; # OE 1129181  ;  BM Transit 300  ;  BM Transit 330  ;  BM Transit 350  ;  BM Transit 430   # 370V1-1 F-556174.XX  ; A/C</p>	<p> 534 0434 10  535 0128 10  FB 7PK2683  538 0262 10  558 0062 10  558 0063 10  558 0066 10  559 0184 10  559 0193 10  559 0193 30</p>
		<p>FAG</p>	<p>right;  left;  ;  → 1.750 kg ;  ;  → 1.850 kg right;  </p>	<p> 821 0264 10  821 0263 10  713 6789 00  713 6789 10  713 6791 10</p>



			SCHAEFFLER
--	---	--	-------------------

FORD

TRANSIT VI / TRANSIT TOURNEO











































































































































2.4 TDCi RWD  PHFA; PHFC; (74kW)	04.06-08.14	FAG	 left; 	 Set	713 6791 00			
					814 0162 10			
					818 0318 10			
					818 0152 10			
			 ;  → 1.750 kg		825 0104 10			
			 ;  1.751 kg →		825 0273 10			
			 ; LHD		840 0134 10			
			 ; RHD					
			 ; LHD		840 0284 10			
			 ; RHD					
					840 0775 10			
			2.4 TDCi  JXFA; JXFC; (85kW)	04.06-08.14	LUK	→07.07; G6;  MT82	GearBOX	462 0204 10
						08.07→; G6;  MT82	GearBOX	462 0211 10
incl.  ; incl.  ; SAC		600 0173 00						
SAC		626 3034 33						
		626 3053 33						
		415 0388 10						
		411 0120 10						
 ; A/C		529 0364 10						
 ; A/C; # OE 1129181		529 0388 10						
 ; A/C		529 0364 30						
 ; A/C; # OE 1129181		529 0388 30						
 ;  BM Transit 430		532 0776 10						
 ;  BM Transit 330								
 ;  BM Transit 350								
 ;  BM Transit 370								
		534 0434 10						
 # 370V1-1 F-556174.XX		535 0128 10						
		FB 7PK2683						
		538 0262 10						
1x		558 0062 10						
1x		559 0184 10						
FAG		 right; 				821 0264 10		
		 left; 				821 0263 10		
		 ;  → 1.750 kg		713 6789 00				
		 ;  ;  → 1.850 kg		713 6789 10				
		 right; 		713 6791 10				
		 left; 		713 6791 00				
				814 0162 10				
				818 0318 10				
				818 0152 10				
		 ;  → 1.750 kg		825 0104 10				
		 ;  1.751 kg →		825 0273 10				
		 ; LHD		840 0134 10				
		 ; RHD						
 ; LHD		840 0284 10						
 ; RHD								
		840 0775 10						
2.4 TDCi RWD  JXFA; JXFC; (85kW)	04.06-08.14	LUK	→07.07; G6;  MT82	GearBOX	462 0204 10			
			08.07→; G6;  MT82	GearBOX	462 0211 10			
			incl.  ; incl.  ; SAC		600 0173 00			
			SAC		626 3034 33			
					626 3053 33			
					415 0388 10			
					411 0120 10			
			 ; A/C		529 0364 10			
			 ; A/C; # OE 1129181		529 0388 10			
			 ; A/C		529 0364 30			
			 ; A/C; # OE 1129181		529 0388 30			



			<p>SCHAEFFLER</p>
--	---	--	--------------------------

FORD

TRANSIT VI / TRANSIT TOURNEO





























































































































<p>2.4 TDCi RWD JXFA; JXFC; (85kW)</p>	<p>04.06-08.14</p>	<p></p>	<p> BM Trnsit 330  BM Transit 350  BM Transit 430  BM Transit 460  BM Transit 300  BM Transit 330  BM Transit 350  BM Transit 430  01.09-→; BM Transit 350  # 370V1-1 F-556174.XX  A/C 1x  558 0062 10 1x  558 0063 10 1x  558 0066 10 1x  559 0184 10 1x  559 0193 10 1x  559 0193 30 FAG  right;   left;   ;  → 1.750 kg  ;  ;  → 1.850 kg  right;   left;   right;   left;   right;   left;   right;   left;   right;   left;   right;   left;   right;   left; </p>	<p> 532 0776 10  532 0776 10  534 0434 10  535 0128 10  FB 7PK2683  538 0262 10  558 0062 10  558 0063 10  558 0066 10  559 0184 10  559 0193 10  559 0193 30  821 0264 10  821 0263 10  713 6789 00  713 6789 10  713 6791 10  713 6791 00  814 0162 10  818 0318 10  818 0152 10  825 0104 10  825 0273 10  840 0134 10  840 0284 10  840 0775 10</p>
<p>2.4 TDCi H9FD; (103kW)</p>	<p>04.06-08.14</p>	<p></p>	<p>→07.07; G6;  MT82 08.07-→; G6;  MT82 G6;  incl.  ; incl.  ; SAC G6;  SAC G6;  ;   ;  HPCR;  ;  SAC G6;  ;  G6;  ;  HPCR;  ;  SAC G6 G6;   ; A/C  ; A/C ; # OE 1129181  ; A/C  ; A/C ; # OE 1129181  ; BM Transit 330  ; BM Transit 350  ; BM Transit 370  ; BM Transit 430  # 370V1-1 F-556174.XX  ; A/C ; # OE 1376751  ; A/C ; # OE 1129182 1x  558 0062 10 1x  559 0184 10 FAG  right;   left; </p>	<p>GearBOX 462 0204 10 GearBOX 462 0211 10  600 0173 00  626 3034 33  626 3053 09  626 3053 33  415 0388 10  411 0120 10  529 0364 10  529 0388 10  529 0364 30  529 0388 30  532 0776 10  534 0434 10  535 0128 10  FB 7PK2683  FB 7PK2875  538 0262 10  558 0062 10  559 0184 10  821 0264 10  821 0263 10</p>



			SCHAEFFLER
--	---	--	-------------------

FORD

TRANSIT VI / TRANSIT TOURNEO





















































































































2.4 TDCi H9FD; (103kW)	04.06-08.14	FAG	 ;  → 1.750 kg	 Set	713 6789 00
			 ;  → 1.850 kg	 Set	713 6789 10
			 right; 	 Set	713 6791 10
			 left; 	 Set	713 6791 00
					814 0162 10
					818 0318 10
					818 0152 10
			 ;  → 1.750 kg		825 0104 10
			 ;  1.751 kg →		825 0273 10
			 ; LHD		840 0134 10
			 ; RHD		
			 ; LHD		840 0284 10
			 ; RHD		
					840 0775 10
			2.4 TDCi RWD H9FB; H9FD; (103kW)	04.06-08.14	LUK
08.07→; G6;  MT82	GearBOX	462 0211 10			
G6; 		600 0173 00			
incl.  ; incl.  ; SAC		626 3034 33			
G6; 		626 3053 09			
 ;  HPCR;  ; 		626 3053 33			
G6; 		626 3053 33			
G6;  ;  HPCR;  ; 		415 0388 10			
G6		411 0120 10			
G6; 		529 0364 10			
	 ; A/C				529 0388 10
	 ; A/C; # OE 1129181				529 0364 30
	 ; A/C				529 0388 30
	 ; A/C; # OE 1129181				529 0388 30
	 ;  BM Transit 460				532 0776 10
	 ;  BM Transit 330				
	 ;  BM Transit 350				
					534 0434 10
	 # 370V1-1 F-556174.XX				535 0128 10
	 ; A/C; # OE 1376751				FB 7PK2683
	 ; A/C; # OE 1129182				FB 7PK2875
					538 0262 10
	1x				558 0062 10
	1x				558 0063 10
	1x				558 0066 10
1x		559 0184 10			
1x		559 0193 10			
1x		559 0193 30			
FAG	 right; 		821 0264 10		
	 left; 		821 0263 10		
	 ;  → 1.750 kg	 Set	713 6789 00		
	 ;  → 1.850 kg	 Set	713 6789 10		
	 right; 	 Set	713 6791 10		
	 left; 	 Set	713 6791 00		
			814 0162 10		
			818 0318 10		
			818 0152 10		
	 ;  → 1.750 kg		825 0104 10		
	 ;  1.751 kg →		825 0273 10		
	 ; LHD		840 0134 10		
	 ; RHD				
	 ; LHD		840 0284 10		
	 ; RHD				
		840 0775 10			
2.4 TDCi RWD H9FD; (103kW)	04.06-08.14	LUK	→07.07; G6;  MT82	GearBOX	462 0204 10
			08.07→; G6;  MT82	GearBOX	462 0211 10



			<p>SCHAEFFLER</p>
--	--	--	--------------------------

FORD

TRANSIT VI / TRANSIT TOURNEO



































































































































































<p>2.4 TDCi RWD H9FD; (103kW)</p>	<p>04.06-08.14</p>	<p>LUK</p>	<p>G6;  incl. ; incl. ; SAC</p> <p>G6;  SAC</p> <p>G6; ; ;  HPCR; ;  SAC</p> <p>G6; ;  HPCR; ;  SAC</p> <p>G6</p> <p>G6;  </p> <p>; A/C</p> <p>; A/C; # OE 1129181</p> <p>; A/C</p> <p>; A/C; # OE 1129181</p> <p>;  BM Transit 330</p> <p>;  BM Transit 350</p> <p>;  BM Transit 430</p> <p>;  BM Transit 460</p> <p></p> <p># 370V1-1 F-556174.XX</p> <p>; A/C; # OE 1376751</p> <p>; A/C; # OE 1129182</p>	<p> 600 0173 00</p> <p> 626 3034 33</p> <p> 626 3053 09</p> <p> 626 3053 33</p> <p> 415 0388 10</p> <p> 411 0120 10</p> <p> 529 0364 10</p> <p> 529 0388 10</p> <p> 529 0364 30</p> <p> 529 0388 30</p> <p> 532 0776 10</p> <p> 534 0434 10</p> <p> 535 0128 10</p> <p> FB 7PK2683</p> <p> FB 7PK2875</p> <p> 538 0262 10</p> <p> 558 0062 10</p> <p> 558 0063 10</p> <p> 558 0066 10</p> <p> 559 0184 10</p> <p> 559 0193 10</p> <p> 559 0193 30</p> <p> 821 0264 10</p> <p> 821 0263 10</p> <p>  Set 713 6789 00</p> <p>  Set 713 6789 10</p> <p>  Set 713 6791 10</p> <p>  Set 713 6791 00</p> <p> 814 0162 10</p> <p> 818 0318 10</p> <p> 818 0152 10</p> <p> 825 0104 10</p> <p> 825 0273 10</p> <p> 840 0134 10</p> <p> 840 0284 10</p> <p> 840 0284 10</p> <p> 840 0284 10</p> <p> 840 0775 10</p> <p> 600 0173 00</p> <p> 626 3034 33</p> <p> 626 3053 09</p> <p> 626 3053 33</p> <p> 415 0388 10</p> <p> 411 0120 10</p> <p> 529 0364 10</p> <p> 529 0388 10</p> <p> 529 0364 30</p> <p> 529 0388 30</p> <p> 532 0776 10</p> <p> 532 0776 10</p>
<p>2.4 TDCi 4x4 H9FB; (103kW)</p>	<p>11.06-08.14</p>	<p>LUK</p>	<p>G6;  incl. ; incl. ; SAC</p> <p>G6;  SAC</p> <p>G6; ;  HPCR; ;  SAC</p> <p>G6; ;  HPCR; ;  SAC</p> <p>G6</p> <p>G6;  </p> <p>; A/C</p> <p>; A/C; # OE 1129181</p> <p>; A/C</p> <p>; A/C; # OE 1129181</p> <p>;  BM Transit 330</p> <p>; BM Transit 350</p> <p>; BM Transit 370</p> <p>; BM Transit 350</p> <p>; BM Transit 330</p>	<p> 600 0173 00</p> <p> 626 3034 33</p> <p> 626 3053 09</p> <p> 626 3053 33</p> <p> 415 0388 10</p> <p> 411 0120 10</p> <p> 529 0364 10</p> <p> 529 0388 10</p> <p> 529 0364 30</p> <p> 529 0388 30</p> <p> 532 0776 10</p> <p> 532 0776 10</p>



			SCHAEFFLER
--	---	--	-------------------

FORD

TRANSIT VI / TRANSIT TOURNEO































2.4 TDCi 4x4 H9FB; (103kW)	11.06-08.14		 ;  BM Transit 330	 532 0776 10	
			 ; 01.10→12.12;  BM Transit 350	 534 0434 10	
				 535 0128 10	
			 # 370V1-1 F-556174.XX	 FB 7PK2683	
			 ;  ; # OE 1376751	 FB 7PK2683	
			 ; 	 FB 7PK2875	
			 ;  ; # OE 1129182	 FB 7PK2875	
			1x	 538 0262 10	
			1x	 558 0062 10	
		FAG	 right; 	 821 0264 10	
			 left; 	 821 0263 10	
			 ;  → 1.750 kg	 Set 713 6789 00	
			 ;  → 1.850 kg	 Set 713 6789 10	
			 right; 	 Set 713 6791 10	
				 Set 713 6791 00	
			 left; 	 Set 713 6791 00	
				 Set 713 6791 00	
				 814 0162 10	
				 818 0318 10	
				 818 0152 10	
			 ;  → 1.750 kg	 825 0104 10	
			 ;  1.751 kg →	 825 0273 10	
			 ;  ; LHD	 840 0134 10	
		 ;  ; RHD	 840 0284 10		
		 ;  ; LHD	 840 0284 10		
		 ;  ; RHD	 840 0284 10		
			 840 0775 10		
3.2 TDCi RWD SAFA; SAFB; (147kW)	09.07-08.14		G6 ;  MT82	GearBOX 462 0211 10	
			10.07→ SAC	 627 3031 33	
			→03.12;  627 3031 09/33	 415 0560 10	
			04.12→	 411 0120 10	
			 ;  BM Transit 350	 532 0776 10	
			 ; 02.08→;  BM Transit 430	 532 0776 10	
			 ;  BM Transit 460	 532 0776 10	
			 ;  BM Transit 460	 532 0776 10	
			 ;  BM Transit 350	 532 0776 10	
			 ; 06.10→;  BM Transit 430	 532 0776 10	
				 534 0434 10	
			 # 370V1-1 F-556174.XX	 535 0128 10	
			 ; 	 FB 7PK2683	
			 ; 	 FB 7PK2843	
				 538 0267 10	
			1x	 558 0062 10	
			FAG	 right; 	 821 0264 10
				 left; 	 821 0263 10
		 ;  → 1.750 kg		 Set 713 6789 00	
		 ;  → 1.850 kg		 Set 713 6789 10	
		 right; 		 Set 713 6791 10	
				 Set 713 6791 00	
		 left; 		 Set 713 6791 00	
				 Set 713 6791 00	
				 814 0162 10	
				 818 0318 10	
				 818 0152 10	
		 ;  → 1.750 kg		 825 0104 10	
		 ;  1.751 kg →		 825 0273 10	
		 ;  ; LHD		 840 0134 10	
		 ;  ; RHD	 840 0284 10		
		 ;  ; LHD	 840 0284 10		
		 ;  ; RHD	 840 0284 10		
			 840 0775 10		
3.2 TDCi SAFA; SAFB; (147kW)	02.08-08.14		G6 ;  MT82	GearBOX 462 0211 10	
			SAC	 627 3031 33	
			→03.12;  627 3031 09/33	 415 0560 10	
			04.12→	 411 0120 10	









































			SCHAEFFLER
--	--	--	-------------------

FORD

TRANSIT VI / TRANSIT TOURNEO

3.2 TDCi SAFA; SAFB; (147kW)	02.08-08.14		BM Transit 350		411 0120 10
			06.10 →; BM Transit 430		532 0776 10
					534 0434 10
			# 370V1-1 F-556174.XX		535 0128 10
			A/C		FB 7PK2683
			A/C		FB 7PK2843
					538 0267 10
			1x		558 0062 10
			right; 		821 0264 10
			left; 		821 0263 10
		; → 1.750 kg		Set 713 6789 00	
		; → 1.850 kg		Set 713 6789 10	
		right; 		Set 713 6791 10	
				Set 713 6791 00	
		left; 		814 0162 10	
				818 0318 10	
				818 0152 10	
		; → 1.750 kg		825 0104 10	
		; 1.751 kg →		825 0273 10	
		LHD		840 0134 10	
RHD		840 0284 10			
LHD		840 0284 10			
RHD		840 0775 10			

TRANSIT VII

2.0 EcoBlue BJFA; BJFB; BKFA; BKFB; YLF6; YLFA; YLFB; YLFS; YMF6; YMFA; YMF6; YMFS; (77-96kW)	03.16-		# 920620		535 0310 10
					FB 3PK715
			A/C		FB 6PK1340
			A/C		FB 6PK1413
			→05.19		Set 713 6791 20
		FAG	250, 260, 270, 280 290, 300, 310		Set 713 6791 50
			330, 350, 390, 410 470		Set 713 6791 60
			↔		818 0318 10
			↔; I STANDARD		825 0104 10
			↔		840 0775 10
2.0 EcoBlue RWD BJRA; YLR6; YLRA; YMHA; YMR6; (77-96kW)	03.16-		# 920620		535 0310 10
					FB 3PK715
			A/C		FB 6PK1340
			A/C		FB 6PK1413
			↔		Set 713 6791 30
		FAG			Set 713 6791 40
					818 0318 10
			↔; I STANDARD		825 0104 10
			↔		840 0775 10
			↔		840 1279 10
2.0 EcoBlue 4x4 BKRA; YMR6; YMRA; (96kW)	01.17-		# 920620		535 0310 10
					FB 3PK715
			A/C		FB 6PK1340
			A/C		FB 6PK1413
			→05.19		Set 713 6791 20
		FAG	↔		818 0318 10
			↔; I STANDARD		825 0104 10
			↔		840 0775 10
			↔		840 1279 10
			2.0 EcoBlue BLFA; BLFB; YNF6; YNFA; YNFB; YNFS; (125kW)	03.16-	
		FB 6PK1340			
→05.19		Set 713 6791 20			
250, 260, 270, 280 290, 300, 310		Set 713 6791 50			
330, 350, 390, 410 470		Set 713 6791 60			



			SCHAEFFLER
--	---	--	-------------------

FORD

















































































































TRANSIT VII			
2.0 EcoBlue BLFA; BLFB; YNF6; YNFA; YNFB; YNFS; (125kW)	03.16-	FAG	818 0318 10
			825 0104 10
			840 0775 10
			840 1279 10
2.0 EcoBlue RWD BLHA; YNR6; (125kW)	03.16-		# 920620
			; A/C
		FAG	Set 713 6791 30
			Set 713 6791 40
			818 0318 10
			825 0104 10
			840 0775 10
			840 1279 10
2.0 EcoBlue 4x4 BLRA; YNR6; YNRA; (125kW)	01.17-		# 920620
			; A/C
		FAG	; →05.19
			Set 713 6791 20
2.2 TDCi CVF5; CY14; CYF5; CYFG; DRF5; DRFF; DRFG; USF6; (74-114kW)	08.13-	LUK	incl. ○; SAC
			SAC
			; 4WD RWD ; A/C
			; FWD ; A/C
			; FWD ; A/C START/STOP
			; RWD 4WD ; A/C
			; FWD ; A/C
			; →12.14; RWD 4WD ; A/C
			; →12.14; RWD 4WD ; A/C
			# F-554766.XX
			; FWD
			; FWD ; A/C
			; A/C
		1x	
		FAG	; →05.19
Set 713 6791 50			
Set 713 6791 60			
818 0318 10			
2.2 TDCi RWD CV24; CVR5; CYR5; DRR5; USR6; UYR6; (74-114kW)	08.13-	LUK	G6 ; MT82
			incl. ○; incl. ; SAC
		SAC	
		SAC	
			; 4WD RWD ; A/C
			; FWD ; A/C
			; FWD ; A/C START/STOP
			; RWD 4WD ; A/C
			; FWD ; A/C
			; →12.14; RWD 4WD ; A/C
			; →12.14; RWD 4WD ; A/C
			# 370V1-1 F-556174.XX
			; FWD
; FWD ; A/C			
; A/C			



			SCHAEFFLER
--	--	--	-------------------

FORD

TRANSIT VII















































2.2 TDCi RWD CV24; CVR5; CYR5; DRR5; USR6; UYR6; (74-114kW)	08.13-	 FAG	1x		538 0465 10
			1x		558 0062 10
					713 6791 30
					713 6791 40
					818 0318 10
					825 0104 10
					840 0775 10
					840 1279 10
					600 0315 00
					626 3093 33
					415 0562 10
					411 0120 10
					529 0442 10
			2.2 TDCi CY14; CYF5; CYFG; (92kW)	08.13-	 FAG
SAC		626 3093 33			
		415 0562 10			
		529 0442 10			
		532 0470 10			
		532 0477 10			
		532 0909 10			
		532 0910 10			
		534 0308 10			
		534 0682 10			
		535 0160 10			
		FB 4EPK922			
		FB 6EPK873			
		FB 6PK1670			
		538 0465 10			
		558 0062 10			
		713 6791 20			
		713 6791 50			
		713 6791 60			
		818 0318 10			
		825 0104 10			
		840 0775 10			
		840 1279 10			
2.2 TDCi 4x4 CY24; CYR5; (92kW)	08.13-	 FAG			
					627 3032 35
			SAC		627 3040 33
					415 0628 10
					411 0120 10
					529 0442 10
					532 0470 10
					532 0477 10
					532 0909 10
					532 0910 10
					534 0308 10
					534 0682 10
					535 0128 10
					FB 4EPK922
					FB 6EPK873
					FB 6PK1670
					FB 6PK1670
					538 0465 10
					558 0062 10
					559 0184 10
					713 6791 20
					818 0318 10
					825 0104 10
					840 0775 10
		840 1279 10			
2.2 TDCi RWD UHR5; (99kW)	08.13-	 FAG	G6; MT82	GearBOX	462 0211 10
			incl. ; incl. ; SAC		600 0262 00
					627 3032 35



			SCHAEFFLER
--	---	--	-------------------

FORD

TRANSIT VII











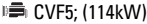





























2.2 TDCi RWD UHR5; (99kW)	08.13-		 SAC	 627 3040 33
			 415 0628 10	
			 411 0120 10	
			 532 0910 10	
			 534 0682 10	
			 535 0128 10	
			 538 0465 10	
			 558 0062 10	
			 559 0184 10	
			 713 6791 30	
			 713 6791 40	
			 818 0318 10	
			 825 0104 10	
			 840 0775 10	
			2.2 TDCi 4x4 CV24; CVR5; (114kW)	08.13-
 SAC	 627 3032 35			
 SAC	 627 3040 33			
 415 0628 10				
 411 0120 10				
 529 0442 10				
 532 0470 10				
 532 0477 10				
 532 0909 10				
 532 0910 10				
 534 0308 10				
 534 0682 10				
 535 0128 10				
 FB 4EPK922				
2.2 TDCi CVF5; (114kW)	12.14-			
			 SAC	 626 3093 33
			 415 0562 10	
			 411 0120 10	
			 529 0442 10	
			 532 0470 10	
			 532 0477 10	
			 532 0909 10	
			 532 0910 10	
			 534 0308 10	
			 535 0160 10	
			 FB 4EPK922	
			 FB 6EPK873	
			 FB 6PK1670	
			 558 0062 10	



























































































































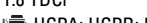



















			SCHAEFFLER
--	--	--	-------------------

FORD

TRANSIT VII

2.2 TDCi  CVF5; (114kW)	12.14-	FAG	 ↔	 840 0775 10
2.2 TDCi All-wheel Drive 2.2 TDCi Allrad 2.2 TDCi A las 4 ruedas 2.2 TDCi Traction intégrale 2.2 TDCi Trazione integrale 2.2 TDCi Napęd na 4 koła 2.2 TDCi Привод на все колеса  (114kW)	12.14-	LUK	incl.  ; incl.  ; SAC  SAC  SAC  SAC  SAC  SAC  SAC  SAC  SAC  SAC  SAC  SAC	 600 0262 00  627 3032 35  627 3040 33  415 0628 10  411 0120 10  532 0910 10   558 0062 10   559 0184 10   713 6791 20
			 1x  1x	 532 0910 10   558 0062 10   559 0184 10
		FAG	 ; →05.19	  713 6791 20

TRANSIT CONNECT (P65, P70, P80)











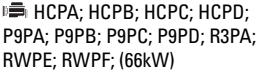

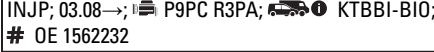















































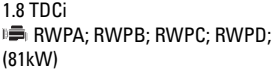



















































1.8 Di  BHPA; P7PA; P7PB; R2PA; (55kW)	06.02-12.13	LUK	G5;  MTX75 →09.04 10.04→02.07;  418 0390 10; LHD 10.04→02.07;  418 0395 10; RHD 03.07→     INJP; 03.08→;  P7PB R2PA;  KTBBI-BIO; # OE 1562232  ; 05.07→; A/C  ; A/C  ; →05.07; A/C  ; →07.05  68 mm  ; →04.07; A/C  ; 05.07→; A/C    # F-233608.01/02/03 OPTION  # F-233608.01/02/03  ; →05.03; A/C  ; 05.03→; A/C                    	GearBOX 462 0153 10  624 3547 09  624 3547 33  624 3547 34  530 0142 10   531 0497 10  533 0098 10   529 0037 10   529 0173 10   529 0463 10   532 0612 10   532 0311 10   534 0146 10   535 0098 10   535 0157 10   FB 6PK1413   FB 6PK1460   538 0256 10   821 0267 10   821 0266 10    713 6788 70    713 6788 80    713 6788 90   771 0411 30   815 0021 30   818 0142 10   818 0143 10   825 0104 10   840 0130 10   840 0778 10 GearBOX 462 0153 10  600 0044 00  623 3124 33  624 3547 09  624 3547 33  624 3547 34  415 0185 10  411 0119 10   530 0142 10   531 0497 10
1.8 TDCi  HCPA; HCPB; HCPD; P9PA; P9PB; P9PC; P9PD; R3PA; RWPE; RWPF; (66kW)	06.02-12.13	LUK	G5;  MTX75 →08.02 incl.  ; incl.  ; SAC →08.02 SAC 09.02→ 09.02→09.04 10.04→02.07;  418 0390 10; LHD 10.04→02.07;  418 0395 10; RHD 03.07→ →08.02 →08.02    	GearBOX 462 0153 10  600 0044 00  623 3124 33  624 3547 09  624 3547 33  624 3547 34  415 0185 10  411 0119 10   530 0142 10   531 0497 10
			   	  530 0142 10   531 0497 10

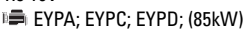

			SCHAEFFLER
--	---	--	-------------------

FORD

TRANSIT CONNECT (P65_, P70_, P80_)

<p>1.8 TDCi </p>	<p>06.02-12.13</p>		<p>INJP; 03.08→; </p>		533 0098 10
			<p> ; 05.07→; A/C</p>		529 0037 10
			<p> ; A/C</p>		529 0173 10
			<p> ; →05.07; A/C</p>		529 0463 10
			<p> ; →07.05</p>		532 0612 10
			<p> 68 mm</p>		
			<p> ; →04.07; A/C</p>		532 0311 10
			<p> ; 05.07→; A/C</p>		
			<p> ;</p>		534 0146 10
			<p> # F-233608.01/02/03</p>		535 0098 10
			<p>OPTION</p>		535 0157 10
			<p> # F-233608.01/02/03</p>		
			<p> ; →05.03; A/C</p>		FB 6PK1413
			<p> ; 05.03→; A/C</p>		FB 6PK1460
			<p>FAG</p>		
<p> 74 mm</p>					
<p> ; ABS</p>		Set 713 6788 80			
<p> 74 mm</p>					
<p> ;</p>		Set 713 6788 90			
<p> ;</p>		771 0411 30			
<p> 91 mm</p>					
<p> ; </p>		REP 815 0021 30			
<p> ;</p>		818 0142 10			
<p> ;</p>		818 0143 10			
<p> ;</p>		825 0104 10			
<p> ;</p>		840 0130 10			
<p> ;</p>		840 0778 10			
<p> ;</p>		SET 755321			
<p>1.8 TDCi </p>	<p>08.06-12.13</p>				
			<p>→02.07;  418 0390 10; LHD</p>		624 3547 09
			<p>→02.07;  418 0395 10; RHD</p>		624 3547 34
			<p>03.07→</p>		
			<p> ;</p>		530 0142 10
			<p> ;</p>		531 0497 10
			<p>INJP; 03.08→; </p>		533 0098 10
			<p> ; 05.07→; A/C</p>		529 0037 10
			<p> ; →05.07; A/C</p>		529 0463 10
			<p> ; →04.07; A/C</p>		532 0311 10
			<p> ; 05.07→; A/C</p>		
			<p> ;</p>		534 0146 10
			<p> # F-233608.01/02/03</p>		535 0098 10
			<p>OPTION</p>		535 0157 10
			<p> # F-233608.01/02/03</p>		
<p> ; A/C</p>		FB 6PK1460			
<p> ;</p>		538 0256 10			
<p>FAG</p>			<p> ; ABS</p>		Set 713 6788 70
			<p> 74 mm</p>		
			<p> ; ABS</p>		Set 713 6788 80
			<p> 74 mm</p>		
			<p> ;</p>		Set 713 6788 90
			<p> ;</p>		771 0411 30
			<p> 91 mm</p>		
			<p> ;</p>		814 0162 10
			<p> ;</p>		818 0142 10
			<p> ;</p>		818 0143 10
			<p> ;</p>		825 0104 10
			<p> ;</p>		840 0130 10
			<p> ;</p>		840 0778 10
			<p> ;</p>		GearBOX 462 0153 10
			<p>1.8 16V </p>	<p>06.02-12.13</p>	
<p>10.04→01.07; LHD;  418 0390 10</p>		622 3174 33			
<p>10.04→01.07; RHD;  418 0395 10</p>					
<p>02.07→</p>					
<p> ;</p>		530 0066 10			
<p> ;</p>		531 0345 10			







































































































FUSO (MITSUBISHI)

			SCHAEFFLER
--	--	--	-------------------











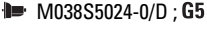





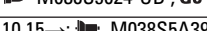



FORD

TRANSIT CONNECT (P65, P70, P80)

1.8 16V EYPA; EYPC; EYPD; (85kW)	06.02-12.13		 ; A/C		532 0187 10
			 ; A/C		529 0281 10
			 ; A/C		529 0385 10
			 ; A/C		532 0545 10
			 ; A/C		534 0130 20
			 ; A/C		FB 6PK2100
			 ; A/C		538 0255 10
			 ; A/C		821 0267 10
			 ; A/C		821 0266 10
			 ; A/C		713 6788 70
		FAG	 right		821 0267 10
			 left		821 0266 10
			 ; ABS		713 6788 70
			 74 mm		713 6788 80
			 ; ABS		713 6788 80
			 74 mm		713 6788 90
			 ; ABS		713 6788 90
			 91 mm		771 0411 30
			 ; MANU		815 0021 30
			 ; MANU		818 0142 10
RUVILLE	 ; 04.03 →		818 0143 10		
	 ; SET		825 0104 10		
	 ; SET		840 0130 10		
	 ; SET		840 0778 10		
	 ; SET		755321		
	 ; GearBOX		462 0153 10		
	 ; G5		530 0066 10		
	 ; G5		531 0345 10		
	 ; G5		532 0187 10		
	 ; G5		529 0281 10		
INA	 ; A/C		529 0385 10		
	 ; A/C		532 0545 10		
	 ; A/C		534 0130 20		
	 ; A/C		FB 6PK2100		
	 ; A/C		538 0255 10		
	 ; A/C		713 6788 70		
	 ; A/C		713 6788 80		
	 ; A/C		713 6788 90		
	 ; A/C		818 0142 10		
	 ; A/C		818 0143 10		
FAG	 ; ABS		825 0104 10		
	 74 mm		840 0130 10		
	 74 mm		840 0778 10		
	 ; ABS		840 0778 10		
	 ; ABS		840 0778 10		
	 ; ABS		840 0778 10		
	 ; ABS		840 0778 10		
	 ; ABS		840 0778 10		
	 ; ABS		840 0778 10		
	 ; ABS		840 0778 10		



















FUSO (MITSUBISHI)

CANTER

3C13 3S13 4P10-T2;	11.10-				628 3294 09
					535 0235 10
3C15 3S15 6S15 7C15 4P10-T4;	11.10-				628 3294 09
					628 3374 09
					630 3131 09
					535 0235 10
3C18 7C18 4P10-T6;	11.10-				535 0235 10

GAZ

GAZELLE

















2.3 2.3 4x4 ZMZ-4063.10; (72-104kW)	09.01-01.10				531 0759 10
			 ; A/C		FB 6PK1218
			 ; A/C		FB 6PK1370
			 16x		420 0061 10
2.3 4x4 ZMZ-4063.10; (112kW)	01.08-01.10				624 3777 00
					512 0018 10
			 ; A/C		531 0759 10



			SCHAEFFLER
--	--	--	-------------------

GAZ

GAZELLE



































































2.3 4x4 ZMZ-4063.10; (112kW)	01.08-01.10		 ; A/C 16x  35 mm	 FB 6PK1370  420 0061 10
2.5 i ZMZ-40522.10; (107-112kW)	01.03-03.13		  	 531 0759 10  FB 6PK1218  FB 6PK1370  624 3777 00  512 0018 10
2.9 2.9 4x4 UMZ-4215.10; UMZ4216; (75-78kW)	01.03-03.13			 624 3777 00  512 0018 10

GAZELLE NEXT

2.9 UMZ4216; (78kW)	04.13-			 624 3777 00  512 0018 10
------------------------	--------	---	--	--

HYUNDAI



























































H-1

2.4 G4CS; (101kW)	02.08-		SOHC	 530 0300 10			
			BS; DOHC	 530 0425 10			
			DOHC	 530 0549 10			
			SOHC	 531 0124 20			
			BS; DOHC	 531 0382 20			
			DOHC	 531 0651 20			
			DOHC	 532 0074 20			
			DOHC	 533 0044 20			
			8x	 420 0200 10			
			 12,96 mm				
			FAG	 713 6267 90			
			2.5 CRDi D4CB; (81kW)	02.08-		→02.15;  2.5L-A SOHC TCI VGT; G5 incl.  ; incl.  ; SAC	 600 0206 00
						→02.15;  2.5L-A SOHC TCI; G5	 600 0219 00
						→02.15; G6 incl.  ; incl.  ; SAC	
SAC	 626 3045 00						
SAC	 626 3045 09						
→02.15;  2.5L-A SOHC TCI VGT; G5 SAC	 628 3166 00						
→02.15;  2.5L-A SOHC TCI VGT; G5	 415 0300 10						
→02.15;  2.5L-A SOHC TCI; G5	 415 0325 10						
→02.15; G6							
	 411 0230 10						
	 534 0341 10						
→01.12 # F-232774.XX	 535 0079 10						
 ;  ; 110 A; # OE 37300-4A310; G5 ; →01.12 # 359V1-2 F-581342.XX	 535 0215 10						
08.10→ # F-576631.XX F-582623	 535 0245 10						
 ; A/C	 FB 7PK1715						
 ; A/C	 FB 7PK2265						
	 538 0660 10						
16x  12 mm	 420 0182 10						
8x; 	 422 0110 10						
8x; 	 422 0063 10						
1x;  ● OILP	 559 0123 10						
1x; 	 559 0127 10						
1x; ●	 559 0128 10						
1x	 559 0126 10						
FAG	 713 6267 90						
2.5 CRDi D4CB; (81kW)	07.10-		→02.15;  2.5L-A SOHC TCI VGT; G5 incl.  ; incl.  ; SAC	 600 0206 00			
			→02.15;  2.5L-A SOHC TCI; G5	 600 0219 00			
			→02.15; G6 incl.  ; incl.  ; SAC				
			→02.15;  TCI; G5	 626 3045 00			
			→02.15; G6				
			SAC	 626 3045 09			



			<p>SCHAEFFLER</p>
--	---	--	--------------------------

















































































HYUNDAI

H-1					
<p>2.5 CRDi D4CB; (81kW)</p>	<p>07.10-</p>	<p>LUK</p>	<p>→02.15;  2.5L-A SOHC TCI VGT; G5 SAC →02.15;  2.5L-A SOHC TCI VGT; G5 →02.15;  2.5L-A SOHC TCI; G5 →02.15; G6</p>	<p> 628 3166 00  415 0300 10  415 0325 10  411 0230 10  534 0341 10  535 0079 10  535 0215 10  535 0245 10  FB 7PK1715  FB 7PK2265  420 0182 10  422 0110 10  422 0063 10  559 0123 10  559 0127 10  559 0128 10  559 0126 10  713 6267 90</p>	
<p>2.5 CRDi D4CB; (85kW)</p>	<p>01.09-</p>	<p>LUK</p>	<p>→02.15 incl. ; incl. ; SAC SAC SAC →02.15</p>	<p> 600 0219 00  626 3045 00  626 3045 09  415 0325 10  411 0230 10  534 0341 10  535 0079 10  535 0215 10  535 0245 10  FB 7PK1715  FB 7PK2265  538 0660 10  420 0182 10  422 0110 10  422 0063 10  559 0123 10  559 0127 10  559 0128 10  559 0126 10  713 6267 90</p>	
<p>2.5 CRDi D4CB; (85kW)</p>	<p>08.11-</p>	<p>LUK</p>	<p>→02.15 incl. ; incl. ; SAC →02.15 SAC SAC →02.15</p>	<p> 600 0219 00  626 3045 00  626 3045 09  415 0325 10  411 0230 10  534 0341 10  535 0079 10  535 0215 10  535 0245 10  FB 7PK1715  FB 7PK2265  538 0660 10  420 0182 10 422 0110 10 422 0063 10 559 0123 10</p>	



			SCHAEFFLER
--	--	--	-------------------

HYUNDAI

H-1						
2.5 CRDi D4CB; (85kW)	08.11-		1x; 	 559 0127 10		
			1x; ●	 559 0128 10		
			1x	 559 0126 10		
		FAG		 713 6267 90		
2.5 CRDi D4CB; (94kW)	01.09-		→02.15;  2.5L-A SOHC TCI VGT; G5 incl. ○; incl.  ; SAC	 600 0206 00		
			→02.15;  2.5L-A SOHC TCI; G5	 600 0219 00		
			→02.15; G6 incl. ○; incl.  ; SAC			
			→02.15;  TCI; G5	 626 3045 00		
			→02.15; G6 SAC			
			SAC	 626 3045 09		
			→02.15;  2.5L-A SOHC TCI VGT; G5 SAC	 628 3166 00		
			→02.15;  2.5L-A SOHC TCI VGT; G5	 415 0300 10		
			→02.15;  2.5L-A SOHC TCI; G5	 415 0325 10		
			→02.15; G6			
				 411 0230 10		
				→01.12 # F-232774.XX	 534 0341 10	
			08.10 → # F-576631.XX F-582623	 535 0079 10		
			 ; A/C	 FB 7PK1715		
			 ; A/C	 FB 7PK2265		
16x 12 mm	 420 0182 10					
8x; 	 422 0110 10					
8x; 	 422 0063 10					
FAG		 713 6267 90				
2.5 CRDi D4CB; (100-125kW)	05.08-		→02.15;  2.5L-A SOHC TCI VGT; G5 incl. ○; incl.  ; SAC	 600 0206 00		
			→02.15;  2.5L-A SOHC TCI; G5	 600 0219 00		
			→02.15; G6 incl. ○; incl.  ; SAC			
			→02.15;  TCI; G5	 626 3045 00		
			→02.15; G6 SAC			
			SAC	 626 3045 09		
			→02.15;  2.5L-A SOHC TCI VGT; G5 SAC	 628 3166 00		
			→02.15;  2.5L-A SOHC TCI VGT; G5	 415 0300 10		
			→02.15;  2.5L-A SOHC TCI; G5	 415 0325 10		
			→02.15; G6			
				 411 0230 10		
				→01.12 # F-232774.XX	 534 0341 10	
			 ; # 110 A; # OE 37300-4A310; G5; →01.12 # 359V1-2 F-581342.XX	 535 0215 10		
			08.10 → # F-576631.XX F-582623	 535 0245 10		
			 ; A/C	 FB 7PK1715		
 ; A/C	 FB 7PK2265					
16x 12 mm	 538 0660 10					
8x; 	 422 0110 10					
8x; 	 422 0063 10					
1x;  ● OILP	 559 0123 10					
1x; 	 559 0127 10					
1x; ●	 559 0128 10					
1x	 559 0126 10					
FAG		 713 6267 90				
2.5 CRDi D4CB; (100kW)	08.09-		→02.15;  2.5L-A SOHC TCI VGT; G5 incl. ○; incl.  ; SAC	 600 0206 00		



			<p>SCHAEFFLER</p>
--	---	--	--------------------------





























































































































HYUNDAI

H-1			
<p>2.5 CRDi D4CB; (100kW)</p>	<p>08.09-</p>	<p>LUK</p> <ul style="list-style-type: none"> →02.15; 2.5L-A SOHC TCI; G5 13.02.2015; G6 incl. ○; incl. ; SAC SAC SAC →02.15; 2.5L-A SOHC TCI VGT; G5 SAC →02.15; 2.5L-A SOHC TCI VGT; G5 →02.15; 2.5L-A SOHC TCI; G5 →02.15; G6 <p>INA</p> <ul style="list-style-type: none"> →01.12 Part # F-232774.XX ; ; 110 A; # OE 37300-4A310; G5; →01.12 Part # 359V1-2 F-581342.XX 08.10→ Part # F-576631.XX F-582623 ; A/C ; A/C 16x 12 mm 8x; 8x; <p>FAG</p> <ul style="list-style-type: none"> Set 	<ul style="list-style-type: none"> 600 0219 00 626 3045 00 626 3045 09 628 3166 00 415 0300 10 415 0325 10 411 0230 10 534 0341 10 535 0079 10 535 0215 10 535 0245 10 FB 7PK1715 FB 7PK2265 538 0660 10 420 0182 10 422 0110 10 422 0063 10 713 6267 90
<p>2.5 CRDi D4BE; D4CB; (103kW)</p>	<p>12.02-10.05</p>	<p>INA</p> <ul style="list-style-type: none"> ; A/C; 3x ; A/C; 1x 02.04→ Part # F-232774.XX ; A/C ; A/C D4CB 16x 12 mm 8x; 8x; <p>FAG</p> <ul style="list-style-type: none"> right ↓ down left ↓ down ; RWD ; 4WD ↓down 	<ul style="list-style-type: none"> 532 0568 10 534 0341 10 535 0079 10 FB 7PK1730 FB 7PK2285 538 0660 10 420 0182 10 422 0110 10 422 0063 10 821 0103 10 821 0102 10 Set 713 6193 00 Set 713 6197 30 Set 713 6190 70 818 0108 10 818 0109 10 825 0085 10 840 0637 10
<p>2.5 CRDi D4CB; (120kW)</p>	<p>02.08-</p>	<p>LUK</p> <ul style="list-style-type: none"> 2.5L-A SOHC TCI VGT; G5 incl. ○; incl. ; SAC 2.5L-A SOHC TCI; G5 G6 incl. ○; incl. ; SAC SAC SAC 2.5L-A SOHC TCI VGT; G5 SAC 2.5L-A SOHC TCI VGT; G5 2.5L-A SOHC TCI; G5 G6 <p>INA</p> <ul style="list-style-type: none"> →01.12 Part # F-232774.XX ; ; 110 A; # OE 37300-4A310; G5; →01.12 Part # 359V1-2 F-581342.XX 08.10→ Part # F-576631.XX F-582623 	<ul style="list-style-type: none"> 600 0206 00 600 0219 00 626 3045 00 626 3045 09 628 3166 00 415 0300 10 415 0325 10 411 0230 10 534 0341 10 535 0079 10 535 0215 10 535 0245 10



			SCHAEFFLER
--	--	--	-------------------

HYUNDAI





































































H-1								
2.5 CRDi D4CB; (120kW)	02.08-		 ; A/C	 FB 7PK1715				
			 ; A/C	 FB 7PK2265				
			16x	 538 0660 10				
			 12 mm	 420 0182 10				
			8x; 	 422 0110 10				
		FAG	02.08-		8x; 	 422 0063 10		
					 	 Set 713 6267 90		
						G5	 600 0206 00	
					incl.  ; incl.  ; SAC	 626 3045 00		
					SAC	 626 3045 09		
2.5 CRDi D4CB; (125kW)	02.08-		SAC	 628 3166 00				
			SAC	 415 0300 10				
			G5	 534 0341 10				
				 535 0079 10				
			→01.12	 535 0215 10				
			02.08-		 # F-232774.XX	 535 0245 10		
					 ;  ; # OE 37300-4A310; G5 ; →01.12	 535 0215 10		
					 # 359V1-2 F-581342.XX	 535 0245 10		
					08.10→	 535 0245 10		
					 # F-576631.XX F-582623	 535 0245 10		
			02.08-		 ; A/C	 FB 7PK1715		
					 ; A/C	 FB 7PK2265		
					16x	 538 0660 10		
					 12 mm	 420 0182 10		
					8x; 	 422 0110 10		
					8x; 	 422 0063 10		
					1x;  ● OILP	 KIT 559 0123 10		
					1x; 	 KIT 559 0127 10		
					1x; ●	 KIT 559 0128 10		
					1x	 KIT OILP 559 0126 10		
FAG					 Set 713 6267 90			
H200 (KMF)								
2.5 TD D4BH; (74kW)	10.01-08.07						 624 3528 00	
							BS	 530 0109 10
								 531 0231 20
			 531 0232 20					
		 ; 2x; OPTION	 FB 4PK1062					
		 ; 2x	 FB 10X1090					
			10.01-08.07		A/C ; OPTION	 FB 10X1100		
					A/C	 FB 13X925		
						 FB 13X950		
						 538 0591 10		
						 428 0127 10		
					FAG	 ; RWD	 Set 713 6193 00	
						 Set 713 6197 30		
						 Set 713 6190 70		
						 818 0108 10		
	 818 0109 10							
	 825 0085 10							
	 840 0099 10							
	 840 0637 10							
2.5 CRDi D4CB; (81kW)	07.01-04.04		G5	 600 0206 00				
			incl.  ; incl.  ; SAC	 628 3166 00				
			G5	 415 0300 10				
			SAC	 411 0230 10				
			G5	 532 0568 10				
			07.01-04.04		 ; A/C ; 3x	 534 0341 10		
					 ; A/C ; 1x	 535 0079 10		
						 534 0341 10		
					 # F-232774.XX	 535 0079 10		
					 ; A/C	 FB 7PK1730		
 ; A/C	 FB 7PK2285							
 538 0660 10								



			SCHAEFFLER
--	--	--	-------------------

























































HYUNDAI

H200 (KMF)

2.5 CRDi D4CB; (81kW)	07.01-04.04		16x	 12 mm		420 0182 10
			8x; 		422 0110 10	
			8x; 		422 0063 10	
			1x;  ● OILP		559 0123 10	
			1x; 		559 0127 10	
			1x; ●		559 0128 10	
			1x		559 0126 10	
			FAG  ; RWD		713 6193 00	
			 ; 4WD		713 6197 30	
					713 6190 70	
					818 0108 10	
					818 0109 10	
			 ↓down		825 0085 10	
					840 0099 10	
					840 0637 10	
2.5 CRDi D4BE; D4CB; (103kW)	08.03-12.07		 ; A/C ; 3x		532 0568 10	
			 ; A/C ; 1x		534 0341 10	
					535 0079 10	
			02.04→		535 0079 10	
			# F-232774.XX		FB 7PK1730	
			 ; A/C		FB 7PK2285	
			 ; A/C		538 0660 10	
			16x		420 0182 10	
			 12 mm		422 0110 10	
			8x; 		422 0063 10	
			8x; 		422 0063 10	
			1x;  ● OILP		559 0123 10	
			1x; 		559 0127 10	
			1x; ●		559 0128 10	
			1x		559 0126 10	
FAG  ; RWD		713 6193 00				
 ; 4WD		713 6197 30				
		713 6190 70				
		818 0109 10				
 ↓down		825 0085 10				
		840 0099 10				
		840 0637 10				

IVECO











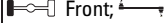



















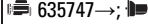

























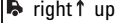

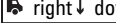











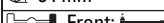

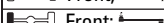



















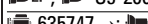





























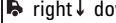



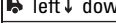





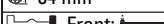

DAILY III

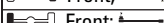
29 L 10 (ALJAV1A1, ALJA41AA, ALJA41A1, AHJA64A1, ...) F1AE0481A; (70kW)	09.02-04.06		 ZF ;  S5-200		624 1313 00
			 ZF ;  S5-200		415 0222 10
			 635747→;  ZF ;  6S-300A		415 0268 10
			 ZF ;  S5-200		411 0186 10
			 635747→;  ZF ;  6S-300A		411 0186 10
					530 0232 10
					530 0232 30
					531 0505 10
					532 0441 10
					532 0298 10
					533 0061 20
			# F-230846.XX		535 0022 10
			A/C ;  113340→		FB 4EPK903
			A/C		FB 4PK985
					FB 7PK1325
		538 0130 10			
FAG  right ↑ up		821 0525 10			
 right ↓ down		821 0527 10			
 left ↑ up		821 0524 10			
 left ↓ down		821 0526 10			
		713 6910 30			
 68 mm		713 6910 20			
 84 mm		713 6910 20			
 Front; 		818 0483 10			



			SCHAEFFLER
--	---	--	-------------------

IVECO





























































































































































DAILY III						
29 L 10 (ALJAV1A1, ALJA41AA, ALJA41A1, AHJA64A1, ..) F1AE0481A; (70kW)	09.02-04.06	FAG	 Front; 		818 0484 10	
			 down  44,95 mm		825 0242 10	
			 up  43,95 mm		825 0243 10	
					840 0046 10	
					840 0622 10	
			 S5-200		624 1313 00	
			 S5-200		415 0222 10	
			 635747 →;  S5-200		415 0268 10	
			 S5-200		411 0186 10	
			 635747 →;  S5-200		411 0186 10	
29 L 10 V (ALJA43A2, ALJA42A2, ALJA41A2) F1AE0481A; (70kW)	09.02-07.07				530 0232 10	
					531 0505 10	
					532 0441 10	
					532 0298 10	
					533 0061 20	
					535 0022 10	
					FB 4EPK903	
					FB 4PK985	
					FB 7PK1325	
					538 0130 10	
29 L 12 (ALKA41A1, AHKA64A1, ALLA51A1) 29 L 12 V (ALKA41A2, ALLA52A2, ALKA42A2) F1AE0481B; (85kW)	09.02-07.07	FAG	 right ↑ up		821 0525 10	
			 right ↓ down		821 0527 10	
			 left ↑ up		821 0524 10	
			 left ↓ down		821 0526 10	
					713 6910 30	
			 68 mm		713 6910 20	
			 84 mm		713 6910 20	
			 Front; 		818 0483 10	
			 Front; 		818 0484 10	
			 down  44,95 mm		825 0242 10	
 up  43,95 mm		825 0243 10				
		840 0046 10				
		840 0622 10				
29 L 12 (ALKA41A1, AHKA64A1, ALLA51A1) 29 L 12 V (ALKA41A2, ALLA52A2, ALKA42A2) F1AE0481B; (85kW)	09.02-07.07	LUK	 S5-200		624 1313 00	
			 S5-200		415 0222 10	
			 635747 →;  S5-200		415 0268 10	
			 S5-200		411 0186 10	
			 635747 →;  S5-200		411 0186 10	
						530 0232 10
						530 0232 30
						531 0505 10
						532 0441 10
						532 0298 10
		533 0061 20				
		535 0022 10				
		FB 4EPK903				
		FB 4PK985				
		FB 7PK1325				
		538 0130 10				
29 L 12 (ALKA41A1, AHKA64A1, ALLA51A1) 29 L 12 V (ALKA41A2, ALLA52A2, ALKA42A2) F1AE0481B; (85kW)	09.02-07.07	FAG	 right ↑ up		821 0525 10	
			 right ↓ down		821 0527 10	
			 left ↑ up		821 0524 10	
			 left ↓ down		821 0526 10	
					713 6910 30	
			 68 mm		713 6910 20	
			 84 mm		713 6910 20	
			 Front; 		818 0483 10	
			 Front; 		818 0484 10	
			 down  44,95 mm		825 0242 10	
 up  43,95 mm		825 0243 10				



			<p>SCHAEFFLER</p>
--	--	--	--------------------------

IVECO

DAILY III



























































































































<p>29 L 12 (ALKA41A1, AHKA64A1, AL-LA51A1) 29 L 12 V (ALKA41A2, ALLA52A2, AL-KA42A2) F1AE0481B; (85kW)</p>	<p>09.02-07.07</p>	<p>FAG</p>	<p> </p>	<p> 840 0046 10  840 0622 10</p>
<p>29 L 13 8140.43S; (92kW)</p>	<p>05.01-07.07</p>	<p>LUK </p>	<p>OPTION</p> <p>  530 0117 10  530 0601 10  532 0239 20  531 0557 10  533 0114 10  531 0480 10  532 0399 20  FB 6PK1053  538 0445 10  428 0080 10 FAG  right ↑ up  821 0525 10  right ↓ down  821 0527 10  left ↑ up  821 0524 10  left ↓ down  821 0526 10   Set 713 6910 30  68 mm  Set 713 6910 20  84 mm  Front;  818 0483 10  Front;  818 0484 10  ↓down  825 0242 10  44,95 mm  ↑up  825 0243 10  43,95 mm   840 0046 10   840 0622 10</p>	<p> 627 3064 00  530 0117 10  530 0601 10  532 0239 20  531 0557 10  533 0114 10  531 0480 10  532 0399 20  FB 6PK1053  538 0445 10  428 0080 10  821 0525 10  821 0527 10  821 0524 10  821 0526 10  Set 713 6910 30  Set 713 6910 20  818 0483 10  818 0484 10  825 0242 10  825 0243 10  840 0046 10  840 0622 10</p>
<p>29 L 13 8140.43S; (92kW)</p>	<p>11.01-04.06</p>	<p>LUK </p>	<p>OPTION</p> <p>  530 0117 10  530 0601 10  532 0239 20  531 0557 10  533 0114 10  531 0480 10  532 0399 20  FB 6PK1053  538 0445 10  428 0080 10 FAG  right ↑ up  821 0525 10  right ↓ down  821 0527 10  left ↑ up  821 0524 10  left ↓ down  821 0526 10  68 mm  Set 713 6910 30  84 mm  Set 713 6910 20  Front;  818 0483 10  Front;  818 0484 10  ↓down  825 0242 10  44,95 mm  ↑up  825 0243 10  43,95 mm   840 0046 10   840 0622 10</p>	<p> 627 3064 00  530 0117 10  530 0601 10  532 0239 20  531 0557 10  533 0114 10  531 0480 10  532 0399 20  FB 6PK1053  538 0445 10  428 0080 10  821 0525 10  821 0527 10  821 0524 10  821 0526 10  Set 713 6910 30  Set 713 6910 20  818 0483 10  818 0484 10  825 0242 10  825 0243 10  840 0046 10  840 0622 10</p>
<p>29 L 14 F1AE0481M; (100kW)</p>	<p>01.05-04.06</p>	<p>LUK </p>	<p> ZF;  S5-200  ZF;  S5-200  635747→;  ZF;  6S-300A  ZF;  S5-200  635747→;  ZF;  6S-300A</p> <p>  530 0232 10   530 0232 30   531 0505 10   532 0441 10 532 0298 10</p>	<p> 624 1313 00  415 0222 10  415 0268 10  411 0186 10  530 0232 10  530 0232 30  531 0505 10  532 0441 10  532 0298 10</p>



			SCHAEFFLER
--	--	--	-------------------

IVECO

DAILY III









































<p>29 L 14 F1AE0481M; (100kW)</p>	<p>01.05-04.06</p>	<p> FAG</p>	<p> F-230846.XX A/C ;  113340→ </p> <p> 68 mm  Front;  Front;  ↓down  44,95 mm  ↑up  43,95 mm </p>	<p> 533 0061 20  535 0022 10  FB 4EPK903  FB 7PK1325  538 0130 10  713 6910 30  818 0483 10  818 0484 10  825 0242 10  825 0243 10  840 0046 10  840 0622 10</p>
<p>29 L 14 (AHRA11C1B1, AHRA14C1B1, AHRA64C1B1) F1AE0481M; (100kW)</p>	<p>11.05-04.06</p>	<p>  FAG</p>	<p> ZF ;  S5-200  ZF ;  S5-200  635747→ ;  ZF ;  6S-300A  ZF ;  S5-200  635747→ ;  ZF ;  6S-300A</p> <p> F-230846.XX A/C ;  113340→ </p> <p> right ↑ up  right ↓ down  left ↑ up  left ↓ down  68 mm  84 mm  Front;  Front;  ↓down  44,95 mm  ↑up  43,95 mm </p>	<p> 624 1313 00  415 0222 10  415 0268 10  411 0186 10  530 0232 10  530 0232 30  531 0505 10  532 0441 10  532 0298 10  533 0061 20  535 0022 10  FB 4EPK903  FB 7PK1325  538 0130 10  821 0525 10  821 0527 10  821 0524 10  821 0526 10  713 6910 30  713 6910 20  818 0483 10  818 0484 10  825 0242 10  825 0243 10  840 0046 10  840 0622 10</p>
<p>29 L 9 8140.43R; (66kW)</p>	<p>11.01-04.06</p>	<p>  FAG</p>	<p> F1AE0481 ;  ZF ;  S5-200  F1AE0481 ;  ZF ;  S5-200  F1AE0481 ;  635747→ ;  ZF ;  6S-300A  F1AE0481 ;  ZF ;  S5-200  F1AE0481 ;  635747→ ;  ZF ;  6S-300A</p> <p>OPTION </p> <p>Ø 65 mm ;  1x A/C ; 1x  ;  BM Daily 29L9</p> <p> ↓down  44,95 mm</p>	<p> 624 1313 00  415 0222 10  415 0268 10  411 0186 10  530 0112 10  530 0602 10  532 0239 20  532 0239 20  533 0114 10  531 0480 10  532 0399 20  FB 6PK1053  538 0469 10  713 6910 30  713 6910 20  818 0483 10  818 0484 10  825 0242 10</p>



			SCHAEFFLER
--	---	--	-------------------

IVECO

DAILY III















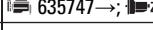







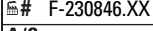





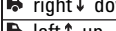

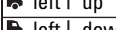



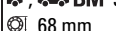









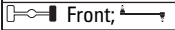



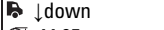
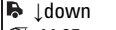

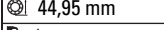
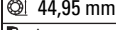

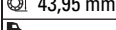











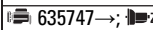











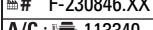







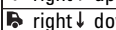

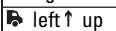

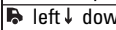



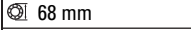
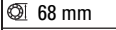

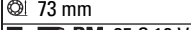
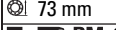

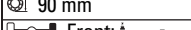
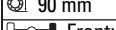

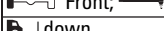
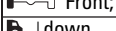

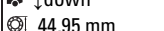
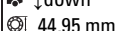

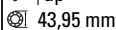
29 L 9 8140.43R; (66kW)	11.01-04.06	FAG	↑up		825 0243 10		
			43,95 mm		840 0046 10		
29 L 9 V 8140.43R; (66kW)	11.01-04.06	LUK	F1AE0481; ZF; S5-200		840 0622 10		
			F1AE0481; ZF; S5-200		624 1313 00		
			F1AE0481; 635747→; ZF; 6S-300A		415 0222 10		
			F1AE0481; ZF; S5-200		415 0268 10		
			F1AE0481; ZF; S5-200		411 0186 10		
			F1AE0481; 635747→; ZF; 6S-300A		411 0186 10		
		INA	OPTION			530 0112 10	
						530 0602 10	
						532 0239 20	
						532 0239 20	
						533 0114 10	
						531 0480 10	
		A/C; 1x		532 0399 20			
				538 0469 10			
FAG			68 mm		713 6910 30		
			84 mm		713 6910 20		
			Front;		818 0483 10		
			Front;		818 0484 10		
			↓down		825 0242 10		
			44,95 mm		825 0243 10		
			↑up		825 0243 10		
			43,95 mm		825 0243 10		
					840 0046 10		
					840 0622 10		
					624 1313 00		
			35 C 10 V, 35 S 10 V (AMJA14A1, AMJA64A1, AMJA65A1, ...) F1AE0481A; (70kW)	09.02-04.06	LUK	ZF; S5-200	
ZF; S5-200		415 0268 10					
635747→; ZF; 6S-300A		411 0186 10					
ZF; S5-200		530 0232 10					
635747→; ZF; 6S-300A		530 0232 30					
		531 0505 10					
INA						532 0441 10	
						532 0298 10	
						533 0061 20	
						535 0022 10	
					A/C; 113340→		FB 4EPK903
					A/C		FB 4PK985
				FB 7PK1325			
				538 0130 10			
FAG			right ↑ up		821 0525 10		
			right ↓ down		821 0527 10		
			left ↑ up		821 0524 10		
			left ↓ down		821 0526 10		
			BM 35 S 10 V		713 6910 30		
			68 mm		713 6911 20		
			BM 35 C 10 V		713 6911 30		
			73 mm		713 6911 30		
			BM 35 C 10 V		713 6911 30		
			90 mm		713 6911 30		
			Front;		818 0483 10		
			Front;		818 0484 10		
↓down		825 0242 10					
44,95 mm		825 0242 10					
↑up		825 0243 10					
43,95 mm		825 0243 10					
		840 0046 10					
		840 0622 10					
		624 1313 00					
		415 0222 10					
		415 0268 10					
35 C 12, 35 S 12 (AEKA14A1, AEKA14AA, AEKA64A1, ...) F1AE0481B; (85kW)	09.02-04.06	LUK	ZF; S5-200		415 0222 10		
			ZF; S5-200		415 0268 10		
			635747→; ZF; 6S-300A		415 0268 10		



			SCHAEFFLER
--	---	--	-------------------

IVECO

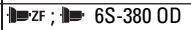
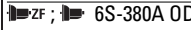
DAILY III



35 C 12, 35 S 12 (AEKA14A1, AEKA14AA, AEKA64A1, ..) F1AE0481B; (85kW)	09.02-04.06		 S5-200	 411 0186 10
			 635747 →;  6S-300A	 530 0232 10
				 530 0232 30
				 531 0505 10
				 532 0441 10
				 532 0298 10
				 533 0061 20
			 # F-230846.XX	 535 0022 10
			A/C	 FB 4EPK903
			A/C;  →113339	 FB 4PK985
			 FB 7PK1325	
			 538 0130 10	
		FAG	 right ↑ up	 821 0525 10
			 right ↓ down	 821 0527 10
			 left ↑ up	 821 0524 10
			 left ↓ down	 821 0526 10
			 ;  BM 35 S 12  68 mm	 Set 713 6910 30
			 ;  BM 35 C 12  73 mm	 Set 713 6911 20
			 ;  BM 35 C 12  90 mm	 Set 713 6911 30
			 Front;  Front;	 818 0483 10
 Front;  Front;	 818 0484 10			
 ↓down  44,95 mm	 825 0242 10			
 ↑up  43,95 mm	 825 0243 10			
	 840 0046 10			
	 840 0622 10			
35 C 12 V, 35 S 12 V (AGKA43A2, AGKB43A2, AGKB46A2, ..) F1AE0481B; (85kW)	09.02-07.07		 5S-200	 624 1313 00
			 5S-200	 415 0222 10
			 635747 →;  6S-300A	 415 0268 10
			 5S-200	 411 0186 10
			 635747 →;  6S-300A	
				 530 0232 10
				 530 0232 30
				 531 0505 10
				 532 0441 10
				 532 0298 10
			 533 0061 20	
		 # F-230846.XX	 535 0022 10	
		A/C;  113340 →	 FB 4EPK903	
		A/C;  →113339	 FB 4PK985	
			 FB 7PK1325	
			 538 0130 10	
		FAG	 right ↑ up	 821 0525 10
			 right ↓ down	 821 0527 10
			 left ↑ up	 821 0524 10
			 left ↓ down	 821 0526 10
 ;  BM 35 S 12 V  68 mm	 Set 713 6910 30			
 ;  BM 35 C 12 V  73 mm	 Set 713 6911 20			
 ;  BM 35 C 12 V  90 mm	 Set 713 6911 30			
 Front;  Front;	 818 0483 10			
 Front;  Front;	 818 0484 10			
 ↓down  44,95 mm	 825 0242 10			
 ↑up  43,95 mm	 825 0243 10			
	 840 0046 10			
	 840 0622 10			
	 600 0274 00			
35 C 14 F1CE0481A; F1CE0481E; (100kW)	09.04-04.06		 6S-380 OD	
			 6S-380A OD incl.  O; incl. 	



			SCHAEFFLER
--	--	--	-------------------

IVECO











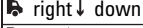

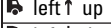

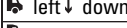





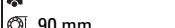

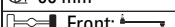



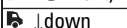



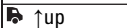







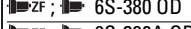





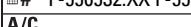





















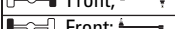

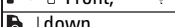



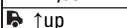





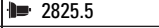































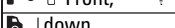

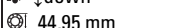



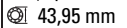







DAILY III

<p>35 C 14  F1CE0481A; F1CE0481E; (100kW)</p>	<p>09.04-04.06</p>	<p>LUK</p>	6S-380 OD incl. ; incl.		600 0274 00	
			6S-380 OD		628 3332 00	
			6S-380 OD		415 0221 10	
			6S-380A OD		415 0268 10	
			635747 →; 6S-300A		411 0186 10	
			635747 →; 6S-300A		411 0186 11	
			6S-380 OD		411 0186 11	
			6S-380A OD		531 0812 10	
					534 0280 10	
			# F-230846.XX		535 0022 10	
		# F-550532.XX F-556500.XX		535 0103 10		
		A/C		FB 4EPK1102		
				FB 6PK1218		
				538 0472 10		
		<p>FAG</p>			713 6911 20	
			73 mm		713 6911 30	
			90 mm		818 0483 10	
			Front;		818 0484 10	
			Front;		825 0242 10	
			↓down		825 0243 10	
			44,95 mm		825 0243 10	
			↑up		840 0046 10	
			43,95 mm		840 0622 10	
					628 3182 00	
			415 0268 10			
			411 0186 10			
			530 0232 10			
			530 0232 30			
<p>35 C 14, 35 S 14  F1AE0481M; (100kW)</p>	<p>01.05-04.06</p>	<p>LUK</p>	5S-300		628 3182 00	
			635747 →; 5S-300		415 0268 10	
			6S-300A		411 0186 10	
			635747 →; 5S-300		411 0186 10	
			6S-300A		530 0232 10	
					530 0232 30	
					531 0505 10	
					532 0441 10	
					532 0298 10	
					533 0061 20	
		# F-230846.XX		535 0022 10		
		# F-550532.XX F-556500.XX		535 0103 10		
		A/C ; 113340 →		FB 4EPK903		
				FB 7PK1325		
				538 0130 10		
		<p>FAG</p>	BM 35 S 14		713 6910 30	
			68 mm		713 6911 20	
			BM 35 C 14		713 6911 20	
			73 mm		713 6911 30	
			BM 35 C 14		713 6911 30	
			90 mm		818 0483 10	
			Front;		818 0484 10	
			Front;		825 0242 10	
			↓down		825 0242 10	
44,95 mm			825 0243 10			
↑up			825 0243 10			
43,95 mm			840 0046 10			
			840 0622 10			
			628 3332 00			
<p>35 C 15  8140.43N; (107kW)</p>	<p>11.01-04.06</p>	<p>LUK</p>	S6-300		628 3332 00	
					530 0117 10	
		<p>OPTION</p>			530 0601 10	
					532 0239 20	
					531 0557 10	
					533 0114 10	
					531 0480 10	
			Ø 65 mm; 1x		532 0399 20	
			A/C ; 1x		FB 6PK1053	
			; BM Daily 35C15 Daily 35C15P		428 0080 10	
					821 0525 10	
			<p>FAG</p>	right ↑ up		821 0525 10
						821 0525 10



			SCHAEFFLER
--	--	--	-------------------

IVECO













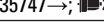

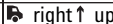
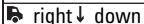

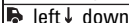

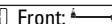

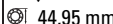

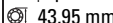

































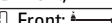

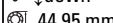

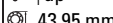























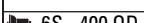

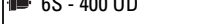
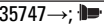
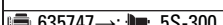
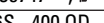





DAILY III			
35 C 15 8140.43N; (107kW)	11.01-04.06	FAG	 right ↓ down  821 0527 10
			 left ↑ up  821 0524 10
			 left ↓ down  821 0526 10
			 73 mm  713 6911 20
			 90 mm  713 6911 30
			 Front;  818 0483 10
			 Front;  818 0484 10
			 ↓down  825 0242 10
			 44,95 mm  825 0243 10
			 ↑up  825 0243 10
			 43,95 mm  840 0046 10
			  840 0622 10
			  840 0622 10
			  628 3191 00
			35 C 17, 35 S 17 F1CE0481B; (122kW)
 ZF;  6S-380A OD  411 0186 11			
 ZF;  6S-380 OD  531 0812 10			
 ZF;  6S-380A OD  534 0280 10			
 ZF;  6S-380 OD  535 0103 10			
	A/C  FB 4EPK1102		
	  FB 6PK1218		
	  538 0472 10		
	  713 6910 30		
	  713 6911 20		
FAG	 BM 35 S 17  713 6911 30		
	 BM 35 C 17  713 6911 20		
	 73 mm  713 6911 30		
	 90 mm  713 6911 30		
	 Front;  818 0483 10		
	 Front;  818 0484 10		
	 ↓down  825 0242 10		
	 44,95 mm  825 0243 10		
	 ↑up  825 0243 10		
	 43,95 mm  840 0046 10		
35 C 9, 35 S 9 8140.43R; (66kW)	11.01-04.06	LUK	 ZF;  5S-200  624 1313 00
			 2825.5  530 0112 10
			OPTION  530 0602 10
			  532 0239 20
			  532 0239 20
			  533 0114 10
			  531 0480 10
			  532 0399 20
			  FB 6PK1053
			  538 0469 10
			  713 6910 30
			  713 6911 20
		FAG	 BM 35 S 9  713 6911 30
			 BM 35 C 9  713 6911 20
			 73 mm  713 6911 30
 90 mm  713 6911 30			
 Front;  818 0483 10			
 Front;  818 0484 10			
 ↓down  825 0242 10			
 44,95 mm  825 0243 10			
 ↑up  825 0243 10			
 43,95 mm  840 0046 10			
35 S 10 (ANJA41A1, ANJA42A2, ANJA42AB, ANJA43A, ANJAV1A, ..) F1AE0481A; (70kW)	09.02-07.07	LUK	 ZF;  5S-200  624 1313 00
			 ZF;  5S-200  415 0222 10
			 635747 →;  ZF;  6S-300A  415 0268 10
			  840 0622 10



			<p>SCHAEFFLER</p>
--	---	--	--------------------------

IVECO

DAILY III



















































































































































<p>35 S 10 (ANJA41A1, ANJA42A2, ANJA42AB, ANJA43A, ANJAV1A, ..) F1AE0481A; (70kW)</p>	<p>09.02-07.07</p>	<p>LUK  S5-200  635747 →;  ZF;  6S-300A</p> <p>INA </p> <p>FAG  right ↑ up  right ↓ down  left ↑ up  left ↓ down  68 mm  Front;  Front;  ↓ down  44,95 mm  ↑ up  43,95 mm</p>	<p> 411 0186 10  530 0232 10  530 0232 30  531 0505 10  532 0441 10  532 0298 10  533 0061 20  535 0022 10  FB 4EPK903  FB 4PK985  FB 7PK1325  538 0130 10  821 0525 10  821 0527 10  821 0524 10  821 0526 10  713 6910 30  818 0483 10  818 0484 10  825 0242 10  825 0243 10  840 0046 10  840 0622 10</p>
<p>35 S 12, 35 C 12, 40 C 12 F1AE0481B; (85kW)</p>	<p>01.03-05.06</p>	<p>LUK  S5-200  S5-200  S5-200</p> <p>INA </p> <p>FAG  BM 35 S 12  68 mm  BM 35 C 12  73 mm  BM 35 C 12  90 mm  Front;  Front;  ↓ down  44,95 mm  ↑ up  43,95 mm</p>	<p> 624 1313 00  415 0222 10  411 0186 10  530 0232 10  530 0232 30  531 0505 10  532 0441 10  532 0298 10  533 0061 20  535 0022 10  FB 4EPK903  FB 7PK1325  538 0130 10  713 6910 30  713 6911 20  713 6911 30  818 0483 10  818 0484 10  825 0242 10  825 0243 10  840 0046 10  840 0622 10</p>
<p>35S14, 35S14 /P F1AE0481H; (100kW)</p>	<p>05.06-08.11</p>	<p>LUK  5S-300  6S - 400 OD  6S - 400 OD  635747 →;  5S - 300  635747 →;  5S-300  6S - 400 OD</p> <p>INA </p>	<p> 628 3182 00  628 3191 00  415 0221 10  415 0268 10  411 0186 10  411 0186 11  530 0232 10  530 0232 30  531 0505 10  532 0441 10  532 0298 10  533 0061 20  535 0022 10  535 0103 10</p>



			SCHAEFFLER
--	--	--	-------------------

IVECO

DAILY III











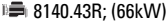









































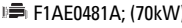

































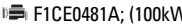





































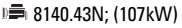

35S14, 35S14 / P F1AE0481H; (100kW)	05.06-08.11		A/C		FB 4EPK903	
					FB 7PK1325	
					538 0130 10	
			 right ↑ up		821 0525 10	
			 right ↓ down		821 0527 10	
			 left ↑ up		821 0524 10	
			 left ↓ down		821 0526 10	
				 Set	713 6911 20	
			 73 mm	 Set	713 6911 10	
			 90 mm			
			 Front; 		818 0483 10	
			 Front; 		818 0484 10	
			 ↓ down		825 0242 10	
			 44,95 mm			
			 ↑ up		825 0243 10	
 43,95 mm						
ZF; 		840 0046 10				
		840 0622 10				
		600 0274 00				
35 S 14, 50 C 14 (ATPA9FH2) F1CE0481A; F1CE0481E; (100kW)	01.04-05.06		 6S-380 OD		628 3332 00	
			incl.  ; incl. 		415 0221 10	
			 6S-380 OD		411 0186 11	
			 6S-380 OD		411 0186 11	
		 # F-550532.XX F-556500.XX		535 0103 10		
			 ;  BM 35 S 14	 68 mm	 Set	713 6910 30
				 ;  BM 50 C 14	 Set	713 6911 20
				 73 mm		
				 ;  BM 50 C 14	 Set	713 6911 30
				 90 mm		
				 Front; 		818 0483 10
				 Front; 		818 0484 10
				 ↓ down		825 0242 10
				 44,95 mm		
				 ↑ up		825 0243 10
 43,95 mm						
		840 0046 10				
		840 0622 10				
35 S 15 V, 35 C 15 V (A6HCV3B2, A6HBV4B2, A6HC41B2, ..) 8140.43N; (107kW)	11.02-07.07		 ZF;  6S-300		628 3332 00	
					530 0117 10	
			OPTION			530 0601 10
						532 0239 20
						531 0557 10
						533 0114 10
				 Ø 65 mm;  ; 1x		531 0480 10
				A/C; 1x		532 0399 20
				 ; →12.06;  BM Daily 35C15 Daily 35S15 Daily 35C15P		FB 6PK1053
						538 0445 10
						428 0080 10
				 right ↑ up		821 0525 10
				 right ↓ down		821 0527 10
				 left ↑ up		821 0524 10
				 left ↓ down		821 0526 10
 ;  BM 35 S 15 V	 Set	713 6910 30				
 68 mm						
 ;  BM 35 C 15 V	 Set	713 6911 20				
 73 mm						
 ;  BM 35 C 15 V	 Set	713 6911 30				
 90 mm						
 Front; 		818 0483 10				
 Front; 		818 0484 10				
 ↓ down		825 0242 10				
 44,95 mm						
 ↑ up		825 0243 10				
43,95 mm						
		840 0046 10				
		840 0622 10				



			SCHAEFFLER
--	--	--	-------------------

IVECO

















































































DAILY III

<p>35 S 9 V  8140.43R; (66kW)</p>	11.01-04.06	  FAG	 ZF ;  5S-200  2825.5	 624 1313 00
			OPTION	 530 0112 10  530 0602 10  532 0239 20  532 0239 20  533 0114 10  531 0480 10  532 0399 20  FB 6PK1053  538 0469 10  713 6910 30
			Ø 65 mm;  1x	 531 0480 10
			A/C; 1x	 532 0399 20
			 FB 6PK1053	 538 0469 10
			 FAG	 713 6910 30
			 68 mm	 818 0483 10
			 Front; 	 818 0484 10
			 Front; 	 818 0484 10
			 ↓down	 825 0242 10
			 44,95 mm	 825 0243 10
			 ↑up	 825 0243 10
			 43,95 mm	 840 0046 10
				 840 0622 10
			<p>40 C 10 (AEJB14A1)  F1AE0481A; (70kW)</p>	09.02-04.06
OPTION	 713 6911 30  818 0483 10  818 0484 10  825 0242 10  825 0243 10  840 0046 10  840 0622 10			
A/C;  113340 →	 FB 4EPK903			
 FB 7PK1325	 538 0130 10			
 FAG	 713 6911 20			
 73 mm	 713 6911 30			
 90 mm	 818 0483 10			
 Front; 	 818 0484 10			
 Front; 	 818 0484 10			
 ↓down	 825 0242 10			
 44,95 mm	 825 0243 10			
 ↑up	 825 0243 10			
 43,95 mm	 840 0046 10			
	 840 0622 10			
<p>40 C 14  F1CE0481A; (100kW)</p>	09.04-04.06	  FAG		
			 ZF ;  6S-380 OD	 628 3332 00
			 ZF ;  6S-380 OD	 415 0221 10
			 ZF ;  6S-380 OD	 411 0186 11
			A/C	 531 0812 10
			 # F-550532.XX F-556500.XX	 534 0280 10
				 535 0103 10
				 538 0472 10
			 FAG	 713 6911 20
			 73 mm	 713 6911 30
			 90 mm	 818 0483 10
			 Front; 	 818 0484 10
			 Front; 	 818 0484 10
			 ↓down	 825 0242 10
			 44,95 mm	 825 0243 10
 ↑up	 825 0243 10			
 43,95 mm	 840 0046 10			
	 840 0622 10			
<p>40 C 15  8140.43N; (107kW)</p>	11.01-04.06	  FAG	 2832.6  ZF ;  S6.300	 628 3332 00
			OPTION	 530 0117 10  530 0601 10  532 0239 20  531 0557 10  533 0114 10



			SCHAEFFLER
--	---	--	-------------------

IVECO













































































































DAILY III													
40 C 15 8140.43N; (107kW)	11.01-04.06	 FAG	 Ø 65 mm;  1x  A/C; 1x 	 531 0480 10  532 0399 20  FB 6PK1053  538 0469 10  428 0080 10  Set 713 6911 20  Set 713 6911 30  818 0483 10  818 0484 10  825 0242 10  825 0243 10  840 0046 10  840 0622 10  628 3191 00									
			40 C 17, 40 S 17 F1CE0481B; (122kW)	01.05-04.06	  FAG	 A/C   # F-550532.XX F-556500.XX  A/C 	 531 0812 10  534 0280 10  535 0103 10  FB 4EPK1102  FB 6PK1218  538 0472 10  Set 713 6910 30  Set 713 6911 20  Set 713 6911 30  818 0483 10  818 0484 10  825 0242 10  825 0243 10  840 0046 10  840 0622 10  628 3191 00						
						40 C 17, 50 C 17 F1CE0481B; (122kW)	01.04-05.06	  FAG	 ZF;  6S-380 OD  ZF;  6S-380 OD  ZF;  6S-380 OD  # F-550532.XX F-556500.XX 	 628 3191 00  415 0221 10  411 0186 11  535 0103 10  Set 713 6911 20  Set 713 6911 30  818 0483 10  818 0484 10  825 0242 10  825 0243 10  840 0046 10  840 0622 10			
									50 C 11 Natural Power (CNG) 8149.03; (78kW)	05.02-05.06	  FAG	 ZF;  S6-300  ;  BM Daily 50 	 627 3064 00  FB 6PK1053  Set 713 6911 20  Set 713 6911 30  818 0483 10  818 0484 10  825 0242 10  825 0243 10  840 0046 10



			SCHAEFFLER
--	--	--	-------------------

IVECO

DAILY III

















































































































50 C 11 Natural Power (CNG) 8149.03; (78kW)	05.02-05.06	FAG			840 0622 10				
50 C 14 F1CE0481A; F1CE0481E; (100kW)	09.04-04.06	LUK		 6S-380 OD incl.  ; incl. 	600 0274 00				
						 ZF ; 6S-380 OD incl.  ; incl. 	600 0274 00		
								 6S-380 OD	628 3332 00
								 ZF ; 6S-380 OD	415 0221 10
								 6S-380 OD 6S-380A OD	415 0221 10
								 ZF ; 6S-380A OD	
		 # F-550532.XX F-556500.XX	 534 0280 10						
				 A/C	 FB 4EPK1102				
		 	 FB 6PK1218						
				 	 538 0472 10				
		 	 Set 713 6911 20						
				 	 Set 713 6911 30				
		 Front; 	 818 0483 10						
				 Front; 	 818 0484 10				
		 down  44,95 mm	 825 0242 10						
				 up  43,95 mm	 825 0243 10				
 	 840 0046 10								
		 	 840 0622 10						
 ZF ; S6-300	 628 3332 00								
				OPTION		 530 0117 10			
 	 530 0601 10								
							 	 532 0239 20	
 	 531 0557 10								
							 	 533 0114 10	
 Ø 65 mm;  ; 1x	 531 0480 10								
							 A/C; 1x	 532 0399 20	
 	 FB 6PK1053								
							 	 538 0445 10	
 	 538 0469 10								
							 	 428 0080 10	
 	 Set 821 0525 10								
							 	 Set 821 0527 10	
 	 Set 821 0524 10								
		 	 Set 821 0526 10						
 	 Set 713 6911 20								
		 	 Set 713 6911 30						
 Front; 	 818 0483 10								
		 Front; 	 818 0484 10						
 down  44,95 mm	 825 0242 10								
		 up  43,95 mm	 825 0243 10						
 	 840 0046 10								
		 	 840 0622 10						
 ZF ; 6S-380 OD	 628 3191 00								
		 ZF ; 6S-380 OD	 415 0221 10						
 ZF ; 6S-380A OD	 411 0186 11								
		 	 531 0812 10						
 	 534 0280 10								
		 # F-550532.XX F-556500.XX	 535 0103 10						
 A/C	 FB 4EPK1102								
		 	 FB 6PK1218						



			SCHAEFFLER
--	--	--	-------------------

IVECO

















































DAILY III

50 C 17 F1CE0481B; (122kW)	09.04-04.06				538 0472 10			
			FAG				713 6911 20	
					73 mm		713 6911 30	
					90 mm			
					Front;		818 0483 10	
					Front;		818 0484 10	
					↓down		825 0242 10	
					44,95 mm			
					↑up		825 0243 10	
					43,95 mm			
							840 0046 10	
							840 0622 10	
				65 C 14 F1CE0481A; F1CE0481E; (100kW)	09.04-04.06			6S-380 OD
	incl. O; incl. 							
	6S-380 OD		628 3332 00					
	6S-380 OD		415 0221 10					
	6S-380 OD		411 0186 11					
	A/C		531 0812 10					
							534 0280 10	
	# F-550532.XX F-556500.XX		535 0103 10					
	A/C		FB 4EPK1102					
							FB 6PK1218	
							538 0472 10	
	FAG							713 6910 40
			88 mm					713 6910 90
			Front;		818 0483 10			
			Front;		818 0484 10			
			↓down		825 0242 10			
			44,95 mm					
			↑up		825 0243 10			
		43,95 mm						
				840 0046 10				
		↔		840 0622 10				
				840 0622 10				
65 C 15 8140.43N; (107kW)		11.01-04.06			2832.6		628 3332 00	
					S6-300			
				2832.6		628 3332 00		
				ZF; S6.300				
				OPTION		530 0117 10		
						530 0601 10		
						532 0239 20		
						531 0557 10		
						533 0114 10		
				Ø 65 mm;  ; 1x		531 0480 10		
				A/C; 1x		532 0399 20		
							FB 6PK1053	
					BM Daily 65C15 Daily 65C15P Daily 65C15S		FB 6PK1053	
				538 0445 10				
				538 0469 10				
				428 0080 10				
FAG			right ↑ up		821 0525 10			
		right ↓ down		821 0527 10				
		left ↑ up		821 0524 10				
		left ↓ down		821 0526 10				
				713 6910 40				
		88 mm		713 6910 90				
		Front;		818 0483 10				
		Front;		818 0484 10				
		↓down		825 0242 10				
		44,95 mm						
		↑up		825 0243 10				
		43,95 mm						
				840 0046 10				
			840 0622 10					

















































































			SCHAEFFLER
--	--	--	-------------------

IVECO**DAILY III**

65 C 17 F1CE0481B; (122kW)	09.04-04.06		 ZF ;  6S-380 OD		628 3191 00
			 ZF ;  6S-380 OD		415 0221 10
			 ZF ;  6S-380A OD		411 0186 11
			 ZF ;  6S-380 OD		411 0186 11
			 ZF ;  6S-380A OD		411 0186 11
			A/C		531 0812 10
					534 0280 10
			# F-550532.XX F-556500.XX		535 0103 10
			A/C		FB 4EPK1102
					FB 6PK1218
		FAG			713 6910 40
			 88 mm		713 6910 90
					713 6910 90
			 Front; 		818 0483 10
			 Front; 		818 0484 10
			 ↓down		825 0242 10
			 44,95 mm		825 0242 10
 ↑up			825 0243 10		
 43,95 mm			825 0243 10		
			840 0046 10		
			840 0622 10		

DAILY IV











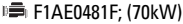



































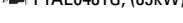

















































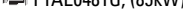







29L10 F1AE0481F; (70kW)	05.06-08.11		MY 2008;  6S-300		624 1313 00
			MY 2009;  6S-300		628 3182 00
			MY 2009;  6S-300		415 0222 10
			 6S-400A OD		415 0268 10
			MY 2009;  6S-400A OD 5S-300		415 0268 10
					411 0186 10
				530 0232 10	
				530 0232 30	
				531 0505 10	
				532 0441 10	
				532 0298 10	
				533 0061 20	
			# F-230846.XX		535 0022 10
			A/C		FB 4EPK903
			A/C		FB 4PK985
					FB 7PK1325
					538 0130 10
		FAG	 right ↑ up		821 0525 10
			 right ↓ down		821 0527 10
			 left ↑ up		821 0524 10
			 left ↓ down		821 0526 10
					713 6911 20
			 73 mm		713 6911 20
			 90 mm		713 6911 10
			 Front; 		818 0483 10
			 Front; 		818 0484 10
			 ↓down		825 0242 10
 44,95 mm		825 0242 10			
 ↑up		825 0243 10			
 43,95 mm		825 0243 10			
ZF; 		840 0046 10			
		840 0622 10			
29L10 V F1AE0481F; (70kW)	05.06-08.11		MY 2008;  5S - 300		624 1313 00
			MY 2009;  5S-300		628 3182 00
			MY 2008;  5S - 300		415 0222 10
			MY 2009;  6S-400A OD		415 0268 10
			 6S - 400A OD		415 0268 10
					411 0186 10
				530 0232 10	
				530 0232 30	
				531 0505 10	
				532 0441 10	
				532 0298 10	
				533 0061 20	



			SCHAEFFLER
--	---	--	-------------------

IVECO

DAILY IV

<p>29L10 V  F1AE0481F; (70kW)</p>	<p>05.06-08.11</p>	<p></p>	<p>№ F-230846.XX</p> <p>A/C</p> <p>A/C</p> <p></p> <p> right ↑ up</p> <p> right ↓ down</p> <p> left ↑ up</p> <p> left ↓ down</p> <p></p> <p>73 mm</p> <p> 90 mm</p> <p> Front; </p> <p> Front; </p> <p> ↓down</p> <p> 44,95 mm</p> <p> ↑up</p> <p> 43,95 mm</p> <p>ZF; </p> <p></p>	<p> 535 0022 10</p> <p> FB 4EPK903</p> <p> FB 4PK985</p> <p> FB 7PK1325</p> <p> 538 0130 10</p> <p> 821 0525 10</p> <p> 821 0527 10</p> <p> 821 0524 10</p> <p> 821 0526 10</p> <p> 713 6911 20</p> <p> 713 6911 10</p> <p> 818 0483 10</p> <p> 818 0484 10</p> <p> 825 0242 10</p> <p> 825 0243 10</p> <p> 840 0046 10</p> <p> 840 0622 10</p>
<p>29L12  F1AE0481G; (85kW)</p>	<p>05.06-08.11</p>	<p></p>	<p>2006MY 2008;  ZF;  5S-300</p> <p>MY 2009;  ZF;  5S-300</p> <p>MY 2009;  ZF;  5S-300</p> <p> 635747 →;  6S-400A OD</p> <p>MY 2009;  635747 →;  6S-400A OD 5S-300</p> <p>MY 2006;  635747 →;  ZF;  6S-400A OD</p> <p>MY 2009;  ZF;  5S-300</p> <p>MY 2009;  635747 →;  ZF;  6S-400A OD</p> <p>MY 2009;  635747 →;  ZF;  5S-300</p>	<p> 624 1313 00</p> <p> 628 3182 00</p> <p> 415 0222 10</p> <p> 415 0268 10</p> <p> 411 0186 10</p> <p> 530 0232 10</p> <p> 530 0232 30</p> <p> 531 0505 10</p> <p> 532 0441 10</p> <p> 532 0298 10</p> <p> 533 0061 20</p> <p> 535 0022 10</p> <p> FB 4EPK903</p> <p> FB 7PK1325</p> <p> 538 0130 10</p> <p> 821 0525 10</p> <p> 821 0527 10</p> <p> 821 0524 10</p> <p> 821 0526 10</p> <p> 713 6911 20</p> <p> 713 6911 10</p> <p> 818 0483 10</p> <p> 818 0484 10</p> <p> 825 0242 10</p> <p> 825 0243 10</p> <p> 840 0046 10</p> <p> 840 0622 10</p>
<p>29L12 V, 29L12 V/P  F1AE0481G; (85kW)</p>	<p>05.06-08.11</p>	<p></p>	<p>MY 2008;  5S - 300</p> <p>MY 2009;  5S-300</p> <p>MY 2008;  5S - 300</p> <p>MY 2009;  635747 →;  5S - 300 6S - 400A OD</p>	<p> 624 1313 00</p> <p> 628 3182 00</p> <p> 415 0222 10</p> <p> 415 0268 10</p> <p> 411 0186 10</p> <p> 530 0232 10</p> <p> 530 0232 30</p> <p> 531 0505 10</p> <p> 532 0441 10</p> <p> 532 0298 10</p> <p> 533 0061 20</p> <p> 535 0022 10</p>



			<p>SCHAEFFLER</p>
--	---	--	--------------------------

IVECO

DAILY IV

29L12 V, 29L12 V/P
 F1AE0481G; (85kW)

05.06-08.11



A/C



FB 4EPK903



FB 7PK1325

FAG

right ↑ up



821 0525 10

right ↓ down



821 0527 10

left ↑ up



821 0524 10

left ↓ down



821 0526 10



713 6911 20

73 mm



713 6911 10



90 mm



713 6911 10

Front; →



818 0483 10

Front; →



818 0484 10

↓down



825 0242 10

44,95 mm

↑up



825 0243 10

43,95 mm

ZF; →



840 0046 10

↔



840 0622 10

29L14
 F1AE0481H; (100kW)

05.06-08.11



5S-300



628 3182 00

635747 →; 5S-300 6S-400A OD



415 0268 10

635747 →; 5S-300 6S-400A OD



411 0186 10



530 0232 10



530 0232 30



531 0505 10



532 0441 10



532 0298 10



533 0061 20

F-230846.XX



535 0022 10



FB 4EPK903



FB 7PK1325



538 0130 10

FAG

right ↑ up



821 0525 10

right ↓ down



821 0527 10

left ↑ up



821 0524 10

left ↓ down



821 0526 10



713 6911 20

73 mm



713 6911 10



90 mm



713 6911 10

Front; →



818 0483 10

Front; →



818 0484 10

↓down



825 0242 10

44,95 mm

↑up



825 0243 10

43,95 mm

ZF; →



840 0046 10

↔



840 0622 10

29L14 C, 29L14 C/P, 29L14 V, 29L14 V/P
 F1AE0481H; (100kW)

05.06-08.11



5S-300



628 3182 00

635747 →; 5S - 300 6S - 400A OD



415 0268 10

5S - 300 6S - 400A OD



411 0186 10



530 0232 10



530 0232 30



531 0505 10



532 0441 10



532 0298 10



533 0061 20

F-230846.XX



535 0022 10

A/C



FB 4EPK903

↔



FB 7PK1325



538 0130 10

FAG

right ↑ up



821 0525 10

right ↓ down



821 0527 10

left ↑ up



821 0524 10

left ↓ down



821 0526 10



713 6911 20

73 mm



713 6911 10



90 mm













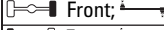

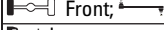































































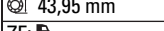









































713 6911 10



			SCHAEFFLER
--	--	--	-------------------

IVECO

DAILY IV











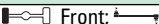





























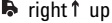



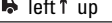

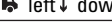









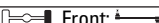

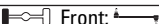



































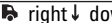



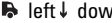







29L14 C, 29L14 C/P, 29L14 V, 29L14 V/P F1AE0481H; (100kW)	05.06-08.11	FAG	 Front;		818 0483 10
			 Front;		818 0484 10
			 ↓down		825 0242 10
			 ↓ 44,95 mm		
			 ↑up		825 0243 10
			 ↑ 43,95 mm		
			ZF; 		840 0046 10
			 ↔		840 0622 10
					624 1313 00
					415 0222 10
			 635747 →;  6S-400A OD		415 0268 10
			 5S-300		411 0186 10
			 635747 →;  6S-400A OD		411 0186 10
					530 0232 10
		530 0232 30			
		531 0505 10			
		532 0441 10			
		532 0298 10			
		533 0061 20			
 # F-230846.XX		535 0022 10			
A/C		FB 4EPK903			
A/C		FB 4PK985			
		FB 7PK1325			
		538 0130 10			
FAG	 right ↑ up		821 0525 10		
	 right ↓ down		821 0527 10		
	 left ↑ up		821 0524 10		
	 left ↓ down		821 0526 10		
			713 6911 20		
	 73 mm		713 6911 10		
	 ;  BM 35S10		713 6911 30		
	 90 mm				
	 ;  BM 35C10				
	 90 mm				
	 Front;		818 0483 10		
	 Front;		818 0484 10		
	 ↓down		825 0242 10		
	 ↓ 44,95 mm				
	 ↑up		825 0243 10		
	 ↑ 43,95 mm				
	ZF; 		840 0046 10		
	 ↔		840 0622 10		
			624 1313 00		
			415 0222 10		
	 635747 →;  6S-400A OD		415 0268 10		
	 ZF;  5S-300		411 0186 10		
	 635747 →;  ZF;  6S-400A OD				
			530 0232 10		
			530 0232 30		
			531 0505 10		
			532 0441 10		
			532 0298 10		
			533 0061 20		
	 # F-230846.XX		535 0022 10		
	A/C		FB 4EPK903		
	A/C		FB 4PK985		
			FB 7PK1325		
			538 0130 10		
FAG	 right ↑ up		821 0525 10		
	 right ↓ down		821 0527 10		
	 left ↑ up		821 0524 10		
	 left ↓ down		821 0526 10		
			713 6911 20		
	73 mm		713 6911 30		
	90 mm				
	Front;		818 0483 10		

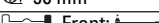

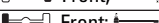
			SCHAEFFLER
--	--	--	-------------------

IVECO





























































































































DAILY IV

35C10 K F1AE0481F; (70kW)	05.06-08.11	FAG	 Front; 		818 0484 10
			 ↓down		825 0242 10
			 44,95 mm		
			 ↑up		825 0243 10
			 43,95 mm		
			ZF; 		840 0046 10
			 ↔		840 0622 10
			 5S-300		628 3182 00
			 5S-300 6S-400A OD		415 0268 10
			 5S-300 6S-400A OD		411 0186 10
					530 0232 10
					530 0232 30
					531 0505 10
					532 0441 10
					532 0298 10
		533 0061 20			
MY 2009		535 0022 10			
# F-230846.XX					
A/C; MY 2009		FB 4EPK903			
; 09.09 →		FB 7PK1325			
		538 0130 10			
FAG	 right ↑ up		821 0525 10		
	 right ↓ down		821 0527 10		
	 left ↑ up		821 0524 10		
	 left ↓ down		821 0526 10		
	 73 mm		713 6911 20		
	 BM 35S11 35S11 D		713 6911 10		
	 90 mm				
	 BM 35C11		713 6911 30		
	 90 mm				
	 Front; 		818 0483 10		
	 Front; 		818 0484 10		
	 ↓down		825 0242 10		
	 ↑up		825 0243 10		
	 43,95 mm				
	ZF; 		840 0046 10		
 ↔		840 0622 10			
35C11 K, 35C11 DK, 35S11 K, 35S11 DK F1AE0481U; (78kW)	07.07-08.11	LUK	 5S-300		628 3182 00
			 635747 →;  5S-300 6S-400A OD		415 0268 10
			 635747 →;  ZF;  5S-300		411 0186 10
			 635747 →;  ZF;  6S-400A OD		
					530 0232 10
					530 0232 30
					531 0505 10
					532 0441 10
					532 0298 10
					533 0061 20
			MY 2009		535 0022 10
			# F-230846.XX		
			A/C; MY 2009		FB 4EPK903
			; 09.09 →		FB 7PK1325
					538 0130 10
FAG	 right ↑ up		821 0525 10		
	 right ↓ down		821 0527 10		
	 left ↑ up		821 0524 10		
	 left ↓ down		821 0526 10		
	 73 mm		713 6911 20		
	 BM 35S11 K 35S11 DK		713 6911 10		
	 90 mm				
	 BM 35C11 K 35C11 DK		713 6911 30		
	 90 mm				
	 Front; 		818 0483 10		
	 Front; 		818 0484 10		
	 ↓down		825 0242 10		
	 44,95 mm				



			SCHAEFFLER
--	--	--	-------------------

IVECO

DAILY IV					
35C11 K, 35C11 DK, 35S11 K, 35S11 DK F1AE0481U; (78kW)	07.07-08.11	FAG	 ↑ up		825 0243 10
			 43,95 mm		
35C11 V, 35S11 V F1AE0481U; (78kW)	07.07-08.11	LUK	ZF; 		840 0046 10
			 ←		840 0622 10
			 5S-300		628 3182 00
			 635747 →;  5S-300 6S-400A OD		415 0268 10
			 5S-300 6S-400A OD		411 0186 10
					530 0232 10
					530 0232 30
					531 0505 10
					532 0441 10
					532 0298 10
			 533 0061 20		533 0061 20
			 # F-230846.XX		535 0022 10
			A/C ; MY 2009		FB 4EPK903
			 ; 09.09 →		FB 7PK1325
		FAG	 right ↑ up		821 0525 10
			 right ↓ down		821 0527 10
			 left ↑ up		821 0524 10
			 left ↓ down		821 0526 10
					713 6911 20
			 73 mm		713 6911 10
			 BM 35S11 V		713 6911 30
			 90 mm		713 6911 30
			 BM 35C11 V		713 6911 30
			 90 mm		713 6911 30
			 Front; 		818 0483 10
			 Front; 		818 0484 10
			 ↓ down		825 0242 10
			 44,95 mm		825 0243 10
			 ↑ up		825 0243 10
			 43,95 mm		825 0243 10
			ZF; 		840 0046 10
			 ←		840 0622 10
35C12 F1AE0481G; (85kW)	05.06-08.11	LUK	 5S-300		624 1313 00
			 2865 S.6		628 3182 00
			 5S-300		415 0222 10
			 635747 →;  6S-400A OD 2865 S.6		415 0268 10
			 5S-300		411 0186 10
			 635747 →;  6S-400A OD 2865 S.6		415 0268 10
					530 0232 10
					530 0232 30
					531 0505 10
					532 0441 10
					532 0298 10
					533 0061 20
			 # F-230846.XX		535 0022 10
			A/C		FB 4EPK903
			 ; 09.09 →		FB 7PK1325
					538 0130 10
		FAG	 right ↑ up		821 0525 10
			 right ↓ down		821 0527 10
			 left ↑ up		821 0524 10
			 left ↓ down		821 0526 10
					713 6911 20
			 73 mm		713 6911 30
			 90 mm		713 6911 30
			 Front; 		818 0483 10
			 Front; 		818 0484 10
			 ↓ down		825 0242 10
			 44,95 mm		825 0243 10
			 ↑ up		825 0243 10
			 43,95 mm		825 0243 10
			ZF; 		840 0046 10
			 ←		840 0622 10





























































			SCHAEFFLER
--	--	--	-------------------

IVECO

DAILY IV



























































35C12, 35S12
 F1AE0481G; F1AE0481R; (85kW)

05.06-08.11

	 5S-300		624 1313 00
	 2865 S.6		628 3182 00
	 5S-300		415 0222 10
	 635747 →;  6S-400A OD 2865 S.6		415 0268 10
	 5S-300		411 0186 10
	 635747 →;  6S-400A OD 2865 S.6		530 0232 10
			530 0232 30
			531 0505 10
			532 0441 10
			532 0298 10
			533 0061 20
			535 0022 10
		FB 4EPK903	
		FB 7PK1325	
		538 0130 10	
FAG	 right ↑ up		821 0525 10
	 right ↓ down		821 0527 10
	 left ↑ up		821 0524 10
	 left ↓ down		821 0526 10
	 73 mm		713 6911 20
	 ;  BM 35S12		713 6911 10
	 90 mm		
	 ;  BM 35C12		713 6911 30
	 90 mm		
	 Front; 		818 0483 10
	 Front; 		818 0484 10
	 ↓down		825 0242 10
	 44,95 mm		
	 ↑up		825 0243 10
	 43,95 mm		
ZF; 		840 0046 10	
		840 0622 10	

35C12 V, 35C12 V/P, 35S12 V, 35S12 V/P
 F1AE0481G; F1AE0481R; (85kW)

































































































































05.06-08.11

	 5S-300		624 1313 00
	 2865 S.6		628 3182 00
	 5S-300		415 0222 10
	 635747 →;  6S-400A OD 2865 S.6		415 0268 10
	 5S-300		411 0186 10
	 635747 →;  6S-400A OD 2865 S.6		530 0232 10
			530 0232 30
			531 0505 10
			532 0441 10
			532 0298 10
			533 0061 20
			535 0022 10
			FB 4EPK903
			FB 4PK985
			FB 7PK1325
			538 0130 10
FAG	 right ↑ up		821 0525 10
	 right ↓ down		821 0527 10
	 left ↑ up		821 0524 10
	 left ↓ down		821 0526 10
	 73 mm		713 6911 20
	 ;  BM 35S12 V 35S12 V/P		713 6911 10
	 90 mm		
	 ;  BM 35C12 V 35C12 V/P		713 6911 30
	 90 mm		
	 Front; 		818 0483 10
	 Front; 		818 0484 10
	 ↓down		825 0242 10
	 44,95 mm		
	 ↑up		825 0243 10
	 43,95 mm		
ZF; 		840 0046 10	



			SCHAEFFLER
--	---	--	-------------------

IVECO



























































































DAILY IV									
35C12 V, 35C12 V/P, 35S12 V, 35S12 V/P F1AE0481G; F1AE0481R; (85kW)	05.06-08.11	FAG	 ↔  840 0622 10						
	35C13, 35C13 /P, 35S13 D, 35S13, 35S13 /P F1AE0481V; (93kW)	07.07-08.11	LUK	 5S-300  628 3182 00  635747 →;  5S-300 6S-400A OD  415 0268 10  635747 →;  5S-300 6S-400A OD  411 0186 10					
				 530 0232 10  530 0232 30  531 0505 10  532 0441 10  532 0298 10  533 0061 20 # F-230846.XX A/C ; MY 2009 ; 09.09 →  535 0022 10  FB 4EPK903  FB 7PK1325  538 0130 10					
				FAG	 right ↑ up  821 0525 10  right ↓ down  821 0527 10  left ↑ up  821 0524 10  left ↓ down  821 0526 10   Set 713 6911 20  73 mm   BM 35S13 D 35S13 35S13 /P   Set 713 6911 10  90 mm   BM 35C13 35C13 /P   Set 713 6911 30  90 mm  Front;   818 0483 10  Front;   818 0484 10  ↓ down  825 0242 10  44,95 mm  ↑ up  825 0243 10  43,95 mm ZF;   840 0046 10  ↔  840 0622 10				
					LUK	 5S-300  628 3182 00  635747 →;  ZF;  5S-300  415 0268 10  635747 →;  ZF;  6S-400A OD  411 0186 10  635747 →;  ZF;  5S-300  411 0186 10  635747 →;  ZF;  6S-400A OD			
							 530 0232 10  530 0232 30  531 0505 10  532 0441 10  532 0298 10  533 0061 20 # F-230846.XX A/C ; MY 2009 ; 09.09 →  535 0022 10  FB 4EPK903  FB 7PK1325  538 0130 10		
							FAG	 right ↑ up  821 0525 10  right ↓ down  821 0527 10  left ↑ up  821 0524 10  left ↓ down  821 0526 10   Set 713 6911 20  73 mm   BM 35S13 K 35S13 DK   Set 713 6911 10  90 mm   BM 35C13 K 35C13 DK   Set 713 6911 30  90 mm  Front;   818 0483 10  Front;   818 0484 10  ↓ down  825 0242 10  44,95 mm  ↑ up  825 0243 10  43,95 mm ZF;   840 0046 10  ↔  840 0622 10	
								LUK	 5S-300  628 3182 00  635747 →;  5S-300 6S-400A OD  415 0268 10



			SCHAEFFLER
--	--	--	-------------------

IVECO

DAILY IV











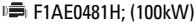







































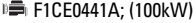

























































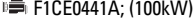























<p>35C13 V, 35C13 V/P, 35S13 V, 35S13 V/P F1AE0481V; (93kW)</p>	<p>07.07-08.11</p>		 6S-400 OD	 411 0186 10		
				 530 0232 10		
			 531 0505 10	 532 0441 10		
			 532 0298 10	 533 0061 20		
			 535 0022 10	 535 0022 10		
			 535 0022 10	 FB 4EPK903		
			 FB 7PK1325	 538 0130 10		
				 821 0525 10		
			 821 0527 10	 821 0524 10		
			 821 0526 10	 821 0526 10		
		 713 6911 20	 Set			
		 713 6911 10	 Set			
		 713 6911 30	 Set			
		 818 0483 10	 818 0484 10			
		 825 0242 10	 825 0243 10			
		 825 0243 10	 840 0046 10			
		 840 0622 10	 840 0622 10			
		<p>35C14, 35C14 /P, 35S14, 35S14 /P, 35S14 D, 35S14 D/P F1CE3481L; (103kW)</p>	<p>09.09-08.11</p>		 6S-400 OD	 600 0274 00
					 6S-400 OD	 628 3332 00
					 6S-400 OD 6S-400A OD	 415 0221 10
 6S-400 OD 6S-400A OD	 411 0186 11					
	 531 0812 10					
 534 0280 10	 535 0103 10					
 535 0176 10	 FB 4EPK1102					
 FB 6PK1218	 FB 6PK1218					
	 821 0525 10					
 821 0527 10	 821 0524 10					
 821 0526 10	 821 0526 10					
 713 6911 20	 Set					
 713 6911 10	 Set					
 713 6911 30	 Set					
 818 0483 10	 818 0484 10					
 825 0242 10	 825 0243 10					
 825 0243 10	 840 0046 10					
 840 0622 10	 840 0622 10					
<p>35C14, 35S14, 35S14 /P F1AE0481H; (100kW)</p>	<p>05.06-08.11</p>				 5S-300	 628 3182 00
					 6S-400 OD	 415 0268 10
		 6S-400 OD	 411 0186 10			
			 530 0232 10			
		 530 0232 30	 531 0505 10			
		 532 0441 10	 532 0298 10			
		 533 0061 20	 533 0061 20			
		 535 0022 10	 535 0022 10			
		 535 0103 10	 535 0103 10			



			SCHAEFFLER
--	---	--	-------------------

IVECO







































































































































DAILY IV

35C14, 35S14, 35S14 /P  F1AE0481H; (100kW)	05.06-08.11		A/C		FB 4EPK903
				FB 7PK1325	
				538 0130 10	
			 right ↑ up		821 0525 10
			 right ↓ down		821 0527 10
			 left ↑ up		821 0524 10
			 left ↓ down		821 0526 10
					713 6911 20
			 73 mm		713 6911 10
			 ;  BM 35S14 35S14 /P		713 6911 30
			 90 mm		
			 ;  BM 35C14		713 6911 30
			 90 mm		
			 Front; 		818 0483 10
			 Front; 		818 0484 10
			 ↓down		825 0242 10
			 44,95 mm		
			 ↑up		825 0243 10
 43,95 mm					
ZF; 		840 0046 10			
		840 0622 10			
35C14 G, 35C14 G/P, 35S14 G, 35S14 G/P, 35C14 GD,...  F1CE0441A; (100kW)	07.07-08.11		 6S-400 OD		600 0274 00
			incl.  ; incl. 		
			 6S-400 OD		628 3332 00
			 6S-400 OD 6S-400A OD		415 0221 10
		 6S-400 OD 6S-400A OD		411 0186 11	
			A/C		531 0812 10
					534 0280 10
			 # F-550532.XX F-556500.XX		535 0103 10
			 # F-559894.XX		535 0176 10
			A/C		FB 4EPK1102
					FB 6PK1218
			 right ↑ up		821 0525 10
			 right ↓ down		821 0527 10
			 left ↑ up		821 0524 10
			 left ↓ down		821 0526 10
					713 6911 20
			 73 mm		713 6911 10
			 ;  BM 35S14 G 35S14 G/P 35S14 GD		713 6911 30
 90 mm					
 ;  BM 35C14 G 35C14 G/P 35C14 GD		713 6911 30			
 90 mm					
 Front; 		818 0483 10			
 Front; 		818 0484 10			
 ↓down		825 0242 10			
 44,95 mm					
 ↑up		825 0243 10			
 43,95 mm					
ZF; 		840 0046 10			
		840 0622 10			
35C14 GV, 35C14 GV/P, 35S14 GV, 35S14 GV/P  F1CE0441A; (100kW)	07.07-08.11		 6S-400 OD		600 0274 00
			incl.  ; incl. 		
			 6S-400 OD		628 3332 00
			 6S-400 OD 6S-400A OD		415 0221 10
		 6S-400 OD 6S-400A OD		411 0186 11	
			A/C		531 0812 10
					534 0280 10
			 # F-550532.XX F-556500.XX		535 0103 10
			 # F-559894.XX		535 0176 10
			A/C		FB 4EPK1102
					FB 6PK1218
			 right ↑ up		821 0525 10
			 right ↓ down		821 0527 10
			 left ↑ up		821 0524 10
			 left ↓ down		821 0526 10
					713 6911 20
			 73 mm		



			SCHAEFFLER
--	--	--	-------------------



































































































IVECO**DAILY IV**

 35C14 GV, 35C14 GV/P, 35S14 GV, 35S14 GV/P F1CE0441A; (100kW)	07.07-08.11	FAG	 ;  BM 35S14 GV 35S14 GV/P		713 6911 10			
			 90 mm		713 6911 30			
			 ;  BM 35C14 GV 35C14 GV/P	 90 mm				
			 Front; 		818 0483 10			
			 Front; 		818 0484 10			
			 ↓down		825 0242 10			
			 ↑up		825 0243 10			
			 43,95 mm					
			ZF; 		840 0046 10			
					840 0622 10			
			35C14 K, 35C14 DK, 35S14 K, 35S14 DK F1CE3481L; (103kW)	09.09-08.11	LUK	 6S-400 OD incl.  ; incl. 		600 0274 00
						 6S-400 OD		628 3332 00
						 6S-400 OD 6S-400A OD		415 0221 10
						 ZF;  6S-400 OD		411 0186 11
						 ZF;  6S-400A OD		
	A/C				531 0812 10			
					534 0280 10			
	 # F-550532.XX F-556500.XX				535 0103 10			
	 # F-559894.XX				535 0176 10			
	A/C				FB 4EPK1102			
FAG						FB 6PK1218		
		 right ↑ up				821 0525 10		
		 right ↓ down				821 0527 10		
		 left ↑ up				821 0524 10		
		 left ↓ down				821 0526 10		
			713 6911 20					
	 73 mm							
	 ;  BM 35S14 K 35S14 DK		713 6911 10					
	 90 mm							
	 ;  BM 35C14 K 35C14 DK		713 6911 30					
	 90 mm							
	 Front; 		818 0483 10					
	 Front; 		818 0484 10					
	 ↓down		825 0242 10					
	 ↑up		825 0243 10					
 43,95 mm								
ZF; 		840 0046 10						
		840 0622 10						
35C14 V, 35C14 V/P, 35S14 V, 35S14 V/P F1CE3481L; (103kW)	09.09-08.11	LUK	 6S-400 OD incl.  ; incl. 		600 0274 00			
			 6S-400 OD		628 3332 00			
			 6S-400 OD 6S-400A OD		415 0221 10			
			 6S-400 OD 6S-400A OD		411 0186 11			
				A/C		531 0812 10		
					534 0280 10			
		 # F-550532.XX F-556500.XX			535 0103 10			
		 # F-559894.XX			535 0176 10			
		A/C			FB 4EPK1102			
		FAG				FB 6PK1218		
				 right ↑ up		821 0525 10		
				 right ↓ down		821 0527 10		
				 left ↑ up		821 0524 10		
				 left ↓ down		821 0526 10		
					713 6911 20			
 73 mm								
 ;  BM 35S14 V 35S14 V/P			713 6911 10					
 90 mm								
 ;  BM 35C14 V 35C14 V/P			713 6911 30					
 90 mm								
 Front; 			818 0483 10					
 Front; 			818 0484 10					
 ↓down			825 0242 10					
 44,95 mm								



			SCHAEFFLER
--	--	--	-------------------













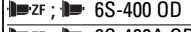

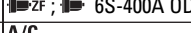































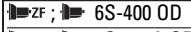

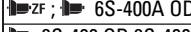
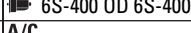





























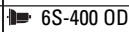



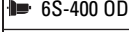

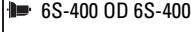

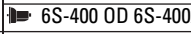

IVECO

DAILY IV				
35C14 V, 35C14 V/P, 35S14 V, 35S14 V/P F1CE3481L; (103kW)	09.09-08.11	FAG	 ↑ up  43,95 mm ZF; 	 825 0243 10  840 0046 10  840 0622 10  600 0274 00
			 ←  6S-400 OD incl.  ; incl. 	 628 3332 00  628 3332 00  6S-400 OD  6S-400 OD 6S-400A OD  415 0221 10  ZF;  6S-400 OD  ZF;  6S-400A OD  411 0186 11
35C15 F1CE0481F; (107kW)	05.06-08.11	LUK	 A/C 	 531 0812 10  534 0280 10  # F-550532.XX F-556500.XX  # F-559894.XX  A/C 
			 A/C 	 FB 4EPK1102  FB 6PK1218  538 0575 10 FAG  right ↑ up  right ↓ down  left ↑ up  left ↓ down  73 mm  90 mm  Front;    Front;   ↓ down  44,95 mm  ↑ up  43,95 mm ZF; 
35C15 V, 35C15 V/P F1CE0481F; (107kW)	05.06-08.11	LUK	 6S-400 OD incl.  ; incl. 	 600 0274 00  628 3332 00  6S-400 OD 6S-400A OD  415 0221 10  6S-400 OD 6S-400A OD  411 0186 11
			 A/C 	 531 0812 10  534 0280 10  # F-550532.XX F-556500.XX  # F-559894.XX  A/C 
35C17, 35C17 /P, 35S17, 35S17 /P, 35S17 D F1CE3481C; (125kW)	07.07-08.11	LUK	 right ↑ up  right ↓ down  left ↑ up  left ↓ down  73 mm  90 mm  Front;   Front;   ↓ down  44,95 mm  ↑ up  43,95 mm ZF; 	 538 0575 10  821 0525 10  821 0527 10  821 0524 10  821 0526 10  713 6911 20  713 6911 30  818 0483 10  818 0484 10  825 0242 10  825 0243 10  840 0046 10  840 0622 10  600 0274 00  628 3332 00  415 0221 10



			SCHAEFFLER
--	--	--	-------------------



























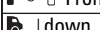

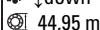

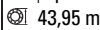

























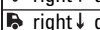

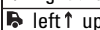















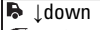

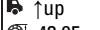





















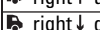

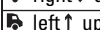

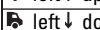

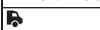











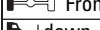

IVECO**DAILY IV**

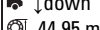
 35C17, 35C17 /P, 35S17, 35S17 /P, 35S17 D F1CE3481C; (125kW)	07.07-08.11	  FAG			411 0186 11
					
			A/C		531 0812 10
					534 0280 10
			# F-550532.XX F-556500.XX		535 0103 10
			# F-559894.XX		535 0176 10
			A/C		FB 4EPK1102
					FB 6PK1218
					538 0130 10
			right ↑ up		821 0525 10
			right ↓ down		821 0527 10
			left ↑ up		821 0524 10
			left ↓ down		821 0526 10
					713 6911 20
			73 mm		713 6911 10
			BM 35S17 35S17 /P 35S17 D		713 6911 30
			90 mm		
			BM 35C17 35C17 /P		713 6911 30
			90 mm		
			Front; 		818 0483 10
Front; 		818 0484 10			
↓down		825 0242 10			
44,95 mm					
↑up		825 0243 10			
43,95 mm					
ZF; 		840 0046 10			
↔		840 0622 10			
35C17 K, 35C17 DK, 35S17 K, 35S17 DK F1CE3481C; (125kW)	07.07-08.11	  FAG			628 3191 00
					415 0221 10
					
					411 0186 11
			A/C		531 0812 10
					534 0280 10
			# F-550532.XX F-556500.XX		535 0103 10
			# F-559894.XX		535 0176 10
			A/C		FB 4EPK1102
					FB 6PK1218
			right ↑ up		821 0525 10
			right ↓ down		821 0527 10
			left ↑ up		821 0524 10
			left ↓ down		821 0526 10
					713 6911 20
			73 mm		713 6911 10
			BM 35S17 K 35S17 DK		713 6911 30
			90 mm		
			BM 35C17 K 35C17 DK		713 6911 30
			90 mm		
Front; 		818 0483 10			
Front; 		818 0484 10			
↓down		825 0242 10			
44,95 mm					
↑up		825 0243 10			
43,95 mm					
ZF; 		840 0046 10			
↔		840 0622 10			
35C17 V, 35C17 V/P, 35S17 V, 35S17 V/P F1CE3481C; (125kW)	07.07-08.11	  FAG			600 0274 00
			incl.  ; incl. 		628 3332 00
					415 0221 10
					411 0186 11
					411 0186 11
			A/C		531 0812 10
					534 0280 10
			# F-550532.XX F-556500.XX		535 0103 10
			# F-559894.XX		535 0176 10
			A/C		FB 4EPK1102
					FB 6PK1218
			right ↑ up		821 0525 10
			right ↓ down		821 0527 10

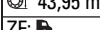

			SCHAEFFLER
--	---	--	-------------------





































IVECO

DAILY IV				
35C17 V, 35C17 V/P, 35S17 V, 35S17 V/P FICE3481C; (125kW)	07.07-08.11	FAG	 left ↑ up  821 0524 10	
			 left ↓ down  821 0526 10	
			 73 mm  Set 713 6911 20	
			 ;  BM 35S17 V 35S17 V/P  90 mm  Set 713 6911 10	
			 ;  BM 35C17 V 35C17 V/P  90 mm  Set 713 6911 30	
			 Front;   818 0483 10	
			 Front;   818 0484 10	
			 ↓ down  44,95 mm  825 0242 10	
			 ↑ up  43,95 mm  825 0243 10	
			ZF;   840 0046 10	
			 ↔  840 0622 10	
			 6S-400 OD  628 3191 00	
			 6S-400 OD 6S-400A OD  415 0221 10	
			 6S-400 OD 6S-400A OD  411 0186 11	
			35C18 FICE0481H; (130kW)	05.06-08.11
 6S-400 OD 6S-400A OD  415 0221 10				
 6S-400 OD 6S-400A OD  411 0186 11				
	A/C  531 0812 10			
	  534 0280 10			
	# F-550532.XX F-556500.XX  535 0103 10			
	A/C  FB 4EPK1102			
	  FB 6PK1218			
	  538 0575 10			
FAG	 right ↑ up  821 0525 10			
	 right ↓ down  821 0527 10			
	 left ↑ up  821 0524 10			
	 left ↓ down  821 0526 10			
	 73 mm  Set 713 6911 20			
	 90 mm  Set 713 6911 30			
	 Front;   818 0483 10			
	 Front;   818 0484 10			
	 ↓ down  44,95 mm  825 0242 10			
	 ↑ up  43,95 mm  825 0243 10			
	ZF;   840 0046 10			
	 ↔  840 0622 10			
	35C18, 35S18 FICE0481H; (130kW)	05.06-08.11	LUK	 6S-400 OD  628 3191 00
				 6S-400 OD 6S-400A OD  415 0221 10
				 6S-400 OD 6S-400A OD  411 0186 11
			A/C  531 0812 10	
			  534 0280 10	
			# F-550532.XX F-556500.XX  535 0103 10	
			A/C  FB 4EPK1102	
			  FB 6PK1218	
			  538 0575 10	
FAG			 right ↑ up  821 0525 10	
			 right ↓ down  821 0527 10	
			 left ↑ up  821 0524 10	
			 left ↓ down  821 0526 10	
			 73 mm  Set 713 6911 20	
			 ;  BM 35S18  90 mm  Set 713 6911 10	
	 ;  BM 35C18  90 mm  Set 713 6911 30			
	 Front;   818 0483 10			
	 Front;   818 0484 10			
	 ↓ down  44,95 mm  825 0242 10			
	 ↑ up  43,95 mm  825 0243 10			
	ZF;   840 0046 10			
	 ↔  840 0622 10			



			SCHAEFFLER
--	--	--	-------------------

IVECO**DAILY IV**



















































































































35C18 V, 35C18 V/P, 35S18 V, 35S18 V/P F1CE0481H; (130kW)	05.06-08.11		 6S-400 OD		628 3191 00		
			A/C		531 0812 10		
35S14 C, 35S14 C/P, 35S14 V, 35S14 V/P, 35C14 V,... F1AE0481H; (100kW)	05.06-08.11		5S-300		628 3182 00		
					530 0232 30		
			right ↑ up		821 0525 10		
			right ↓ down		821 0527 10		
			left ↑ up		821 0524 10		
			left ↓ down		821 0526 10		
			 73 mm		713 6911 20		
			 BM 35S18 V 35S18 V/P		713 6911 10		
			 BM 35C18 V 35C18 V/P		713 6911 30		
			Front; 		818 0483 10		
			↓down		825 0242 10		
			↑up		825 0243 10		
			ZF; 		840 0046 10		
					840 0622 10		
		35S14 K, 35S14 DK F1AE0481H; (100kW)	07.07-08.11		6S-400 OD		628 3191 00
							530 0232 30
							531 0505 10
							532 0441 10
							532 0298 10
							533 0061 20



			SCHAEFFLER
--	---	--	-------------------

IVECO

DAILY IV

<p>35S14 K, 35S14 DK  F1AE0481H; (100kW)</p>	<p>07.07-08.11</p>	<p> FAG</p>	<p> # F-230846.XX  # F-550532.XX F-556500.XX A/C  ; 09.09 →</p> <p> right ↑ up  right ↓ down  left ↑ up  left ↓ down</p> <p> 73 mm  90 mm</p> <p> Front;  Front;  ↓down  44,95 mm  ↑up  43,95 mm ZF;   ↔</p>	<p> 535 0022 10  535 0103 10  FB 4EPK903  FB 7PK1325  538 0130 10  821 0525 10  821 0527 10  821 0524 10  821 0526 10  Set 713 6911 20  Set 713 6911 10  818 0483 10  818 0484 10  825 0242 10  825 0243 10  840 0046 10  840 0622 10  628 3191 00</p>
<p>35S15  F1CE0481L; (110kW)</p>	<p>06.06-08.11</p>	<p> FAG</p>	<p>A/C   # F-550532.XX F-556500.XX  # F-559894.XX</p> <p> right ↑ up  right ↓ down  left ↑ up  left ↓ down</p> <p> 68 mm</p> <p> Front;  Front;  ↓down  44,95 mm  ↑up  43,95 mm ZF;   ↔</p>	<p> 531 0812 10  534 0280 10  535 0103 10  535 0176 10  821 0525 10  821 0527 10  821 0524 10  821 0526 10  Set 713 6910 30  818 0483 10  818 0484 10  825 0242 10  825 0243 10  840 0046 10  840 0622 10  600 0274 00</p>
<p>35S17 W, 35S17 WD  F1CE3481C; (125kW)</p>	<p>07.07-08.11</p>	<p> FAG</p>	<p> 6S-400 OD incl.    6S-400 OD  6S-400 OD 6S-400A OD  6S-400 OD 6S-400A OD</p> <p>A/C   # F-550532.XX F-556500.XX  # F-559894.XX</p> <p>A/C   right ↑ up  right ↓ down  left ↑ up  left ↓ down</p> <p> 90 mm  90 mm</p> <p> Front;  Front;  ↓down  44,95 mm  ↑up  43,95 mm ZF;   ↔</p>	<p> 531 0812 10  534 0280 10  535 0103 10  535 0176 10  FB 4EPK1102  FB 6PK1218  821 0525 10  821 0527 10  821 0524 10  821 0526 10  Set 713 6911 30  Set 713 6911 30  818 0483 10  818 0484 10  825 0242 10  825 0243 10  840 0046 10  840 0622 10</p>



			<p>SCHAEFFLER</p>
--	--	--	--------------------------

IVECO















































































































DAILY IV

<p>40C10 F1AE0481F; (70kW)</p>	<p>05.06-08.11</p>	<p>LUK</p> <ul style="list-style-type: none"> 5S-300 6S-400 OD 5S-300 635747 →; 6S-400 OD 6S-400A OD ZF; 5S-300 635747 →; ZF; 6S-400 OD 635747 →; ZF; 6S-400A OD <p>INA</p> <ul style="list-style-type: none"> 530 0232 10 530 0232 30 531 0505 10 532 0441 10 532 0298 10 533 0061 20 # F-230846.XX A/C A/C FB 4EPK903 FB 4PK985 FB 7PK1325 538 0130 10 <p>FAG</p> <ul style="list-style-type: none"> right ↑ up right ↓ down left ↑ up left ↓ down Set 713 6911 20 73 mm BM 40S10 90 mm BM 40C10 90 mm Front; Front; Front; Front; ↓down 44,95 mm ↑up 43,95 mm ZF; ↔ 	<ul style="list-style-type: none"> 624 1313 00 628 3182 00 415 0222 10 415 0268 10 411 0186 10 530 0232 10 530 0232 30 531 0505 10 532 0441 10 532 0298 10 533 0061 20 535 0022 10 FB 4EPK903 FB 4PK985 FB 7PK1325 538 0130 10 821 0525 10 821 0527 10 821 0524 10 821 0526 10 Set 713 6911 20 Set 713 6911 10 Set 713 6911 30 818 0483 10 818 0484 10 825 0242 10 825 0243 10 840 0046 10 840 0622 10
<p>40C10 V F1AE0481F; (70kW)</p>	<p>05.06-08.11</p>	<p>LUK</p> <ul style="list-style-type: none"> 5S-300 6S-400 OD 5S-300 635747 →; 6S-400 OD 6S-400A OD 5S-300 635747 →; 6S-400 OD 6S-400A OD <p>INA</p> <ul style="list-style-type: none"> 530 0232 10 530 0232 30 531 0505 10 532 0441 10 532 0298 10 533 0061 20 # F-230846.XX A/C A/C FB 4EPK903 FB 4PK985 FB 7PK1325 538 0130 10 <p>FAG</p> <ul style="list-style-type: none"> right ↑ up right ↓ down left ↑ up left ↓ down Set 713 6911 20 73 mm 90 mm Front; Front; Front; Front; ↓down 44,95 mm ↑up 43,95 mm ZF; 	<ul style="list-style-type: none"> 624 1313 00 628 3182 00 415 0222 10 415 0268 10 411 0186 10 530 0232 10 530 0232 30 531 0505 10 532 0441 10 532 0298 10 533 0061 20 535 0022 10 FB 4EPK903 FB 4PK985 FB 7PK1325 538 0130 10 821 0525 10 821 0527 10 821 0524 10 821 0526 10 Set 713 6911 20 Set 713 6911 30 818 0483 10 818 0484 10 825 0242 10 825 0243 10 840 0046 10



			SCHAEFFLER
--	---	--	-------------------

IVECO























































































































DAILY IV					
40C10 V F1AE0481F; (70kW)	05.06-08.11	FAG	 ↔	 840 0622 10	
40C11, 40C11 D F1AE0481U; (78kW)	07.07-08.11	LUK	 5S-300	 628 3182 00	
			 635747 →;  5S-300 6S-400A OD	 415 0268 10	
			 635747 →;  5S-300 6S-400A OD	 411 0186 10	
			 530 0232 10		
			 530 0232 30		
			 531 0505 10		
			 532 0441 10		
			 532 0298 10		
			 533 0061 20		
			 535 0022 10		
			 FB 4EPK903		
			 FB 7PK1325		
			 538 0130 10		
			FAG	 right ↑ up	 821 0525 10
				 right ↓ down	 821 0527 10
				 left ↑ up	 821 0524 10
			 left ↓ down	 821 0526 10	
			 73 mm	 Set 713 6911 20	
		 BM 40S11 40S11 D	 Set 713 6911 10		
		 90 mm			
		 BM 40C11 40C11 D	 Set 713 6911 30		
 90 mm					
 Front;  ↔	 818 0483 10				
 Front;  ↔	 818 0484 10				
 ↓ down	 825 0242 10				
 44,95 mm					
 ↑ up	 825 0243 10				
 43,95 mm					
ZF;  ↔	 840 0046 10				
 ↔	 840 0622 10				
40C11 V F1AE0481U; (78kW)	07.07-08.11	LUK	 5S-300	 628 3182 00	
			 635747 →;  5S-300 6S-400A OD	 415 0268 10	
			 635747 →;  5S-300 6S-400A OD	 411 0186 10	
			 530 0232 10		
			 530 0232 30		
			 531 0505 10		
			 532 0441 10		
			 532 0298 10		
			 533 0061 20		
			 535 0022 10		
			 FB 4EPK903		
			 FB 7PK1325		
			 538 0130 10		
			FAG	 right ↑ up	 821 0525 10
				 right ↓ down	 821 0527 10
				 left ↑ up	 821 0524 10
			 left ↓ down	 821 0526 10	
			 73 mm	 Set 713 6911 20	
		 90 mm	 Set 713 6911 30		
		 Front;  ↔	 818 0483 10		
		 Front;  ↔	 818 0484 10		
 ↓ down	 825 0242 10				
 44,95 mm					
 ↑ up	 825 0243 10				
 43,95 mm					
ZF;  ↔	 840 0046 10				
 ↔	 840 0622 10				
40C12 F1AE0481G; (85kW)	05.06-08.11	LUK	 5S-300	 628 3182 00	
			 635747 →;  5S-300 6S-400A OD	 415 0268 10	
			 635747 →;  5S-300 6S-400A OD	 411 0186 10	
			 530 0232 10		
			 530 0232 30		
			531 0505 10		
			532 0441 10		



			<p>SCHAEFFLER</p>
--	--	--	--------------------------

IVECO

DAILY IV





































































































































<p>40C12 F1AE0481G; (85kW)</p>	<p>05.06-08.11</p>		<p>    # F-230846.XX A/C    right ↑ up   right ↓ down   left ↑ up   left ↓ down    73 mm   90 mm  Front;   Front;   ↓down   44,95 mm  ↑up   43,95 mm ZF;   ↔ </p>	<p>  532 0298 10  533 0061 20  535 0022 10  FB 4EPK903  FB 7PK1325  538 0130 10  821 0525 10  821 0527 10  821 0524 10  821 0526 10  713 6911 20  713 6911 30  818 0483 10  818 0484 10  825 0242 10  825 0243 10  840 0046 10  840 0622 10 </p>
<p>40C12 V, 40C14 V/P F1AE0481G; (85kW)</p>	<p>05.06-08.11</p>		<p>  5S-300  635747 →;  5S-300 6S-400A OD  635747 →;  5S-300 6S-400A OD        BM 40C12  BM 40C14; MY 2009  # F-230846.XX  BM 40C14  # F-550532.XX F-556500.XX A/C;  BM 40C12 A/C;  BM 40C14; MY 2009  </p>	<p>  628 3182 00  415 0268 10  411 0186 10  530 0232 10  530 0232 30  531 0505 10  532 0441 10  532 0298 10  533 0061 20  535 0022 10  535 0103 10  FB 4EPK903  FB 7PK1325  538 0130 10  821 0525 10  821 0527 10  821 0524 10  821 0526 10  713 6911 20  713 6911 30  818 0483 10  818 0484 10  825 0242 10  825 0243 10  840 0046 10  840 0622 10 </p>
<p>40C13, 40C13/P F1AE0481V; (93kW)</p>	<p>07.07-08.11</p>		<p>  ZF;  5S-300  635747 →;  5S-300 6S-400A OD  635747 →;  5S-300 6S-400A OD     # F-230846.XX A/C; MY 2009  ; 09.09 → </p>	<p>  415 0268 10  411 0186 10  530 0232 10  530 0232 30  531 0505 10  532 0441 10  532 0298 10  533 0061 20  535 0022 10  FB 4EPK903  FB 7PK1325  538 0130 10 </p>



			SCHAEFFLER
--	---	--	-------------------

IVECO

























































































































DAILY IV

<p>40C13, 40C13 /P  F1AE0481V; (93kW)</p>	<p>07.07-08.11</p>	<p>FAG</p>	<p> right ↑ up  821 0525 10</p> <p> right ↓ down  821 0527 10</p> <p> left ↑ up  821 0524 10</p> <p> left ↓ down  821 0526 10</p> <p>  713 6911 20</p> <p> 73 mm  713 6911 10</p> <p> ;  BM 40S13 D 40S13 40S13 /P  713 6911 30</p> <p> 90 mm  713 6911 30</p> <p> ;  BM 40C13 40C13 /P  713 6911 30</p> <p> 90 mm</p> <p> Front;   818 0483 10</p> <p> Front;   818 0484 10</p> <p> ↓ down  825 0242 10</p> <p> ↑ up  825 0243 10</p> <p> 44,95 mm</p> <p> 43,95 mm</p> <p>ZF;   840 0046 10</p> <p> ↔  840 0622 10</p>
<p>40C13 V, 40C13 V/P  F1AE0481V; (93kW)</p>	<p>07.07-08.11</p>	<p>LUK</p>	<p> 5S-300  628 3182 00</p> <p> 635747 →;  5S-300 6S-400A OD  415 0268 10</p> <p> 635747 →;  5S-300 6S-400A OD  411 0186 10</p>
		<p></p>	<p> 530 0232 10</p> <p> 531 0505 10</p> <p> 532 0441 10</p> <p> 532 0298 10</p> <p> 533 0061 20</p> <p> 535 0022 10</p> <p>A/C ; MY 2009  FB 4EPK903</p> <p> ; 09.09 →  FB 7PK1325</p> <p> 538 0130 10</p>
		<p>FAG</p>	<p> right ↑ up  821 0525 10</p> <p> right ↓ down  821 0527 10</p> <p> left ↑ up  821 0524 10</p> <p> left ↓ down  821 0526 10</p> <p>  713 6911 20</p> <p> 73 mm  713 6911 30</p> <p> 90 mm  713 6911 30</p> <p> Front;   818 0483 10</p> <p> Front;   818 0484 10</p> <p> ↓ down  825 0242 10</p> <p> ↑ up  825 0243 10</p> <p> 44,95 mm</p> <p> 43,95 mm</p> <p>ZF;   840 0046 10</p> <p> ↔  840 0622 10</p>
<p>40C14, 40C14 /P  F1CE3481L; (103kW)</p>	<p>09.09-08.11</p>	<p>LUK</p>	<p> 6S-400 OD  600 0274 00</p> <p>incl.  </p> <p> 6S-400 OD  628 3332 00</p> <p> 6S-400 OD 6S-400A OD  415 0221 10</p> <p> 6S-400 OD 6S-400A OD  411 0186 11</p>
		<p></p>	<p>A/C  531 0812 10</p> <p> 534 0280 10</p> <p>MY 2009  535 0022 10</p> <p> # F-230846.XX  535 0103 10</p> <p> # F-550532.XX F-556500.XX</p>
		<p>FAG</p>	<p> right ↑ up  821 0525 10</p> <p> right ↓ down  821 0527 10</p> <p> left ↑ up  821 0524 10</p> <p> left ↓ down  821 0526 10</p> <p>  713 6911 20</p> <p> 73 mm  713 6911 10</p> <p> ;  BM 40S14 40S14 /P 40S14 D 40S14 D/P  713 6911 30</p> <p> 90 mm  713 6911 30</p> <p> ;  BM 40C14 40C14 /P  713 6911 30</p> <p> 90 mm</p> <p> Front;   818 0483 10</p> <p> Front;   818 0484 10</p>



			SCHAEFFLER
--	--	--	-------------------

IVECO**DAILY IV**

























































































































40C14, 40C14 /P F1CE3481L; (103kW)	09.09-08.11	FAG	 ↓down		825 0242 10
			 44,95 mm		
40C14 G, 40C14 G/P F1CE0441A; (100kW)	07.07-08.11	LUK	 ↑up		825 0243 10
			 43,95 mm		
			ZF; 		840 0046 10
			 ↔		840 0622 10
		INA	 6S-400 OD		600 0274 00
			incl.  ; incl. 		
			 6S-400 OD		628 3332 00
			 6S-400 OD 6S-400A OD		415 0221 10
		FAG	 6S-400 OD 6S-400A OD		411 0186 11
			A/C		531 0812 10
			MY 2009		534 0280 10
			 # F-230846.XX		535 0022 10
		FAG	 # F-550532.XX F-556500.XX		535 0103 10
			A/C		FB 4EPK1102
					FB 6PK1218
			 right ↑ up		821 0525 10
		FAG	 right ↓ down		821 0527 10
			 left ↑ up		821 0524 10
			 left ↓ down		821 0526 10
					713 6911 20
 73 mm					
  BM 40S14 G 40S14 G/P 40S14 GD			713 6911 10		
 90 mm					
  BM 40C14 G 40C14 G/P 40C14 GD			713 6911 30		
 90 mm					
 Front; 			818 0483 10		
 Front; 			818 0484 10		
 ↓down			825 0242 10		
 ↑up			825 0243 10		
 43,95 mm					
ZF; 			840 0046 10		
 ↔			840 0622 10		
LUK	07.07-08.11	LUK	 6S-400 OD		600 0274 00
			incl.  ; incl. 		
			 6S-400 OD		628 3332 00
			 6S-400 OD 6S-400A OD		415 0221 10
	INA	 6S-400 OD 6S-400A OD		411 0186 11	
		A/C		531 0812 10	
		MY 2009		534 0280 10	
		 # F-230846.XX		535 0022 10	
	FAG	 # F-550532.XX F-556500.XX		535 0103 10	
		A/C		FB 4EPK1102	
				FB 6PK1218	
		 right ↑ up		821 0525 10	
	FAG	 right ↓ down		821 0527 10	
		 left ↑ up		821 0524 10	
		 left ↓ down		821 0526 10	
				713 6911 20	
 73 mm					
  BM 40S14 GV 40S14 GV/P			713 6911 10		
 90 mm					
  BM 40C14 GV 40C14 GV/P			713 6911 30		
 90 mm					
 Front; 			818 0483 10		
 Front; 			818 0484 10		
 ↓down			825 0242 10		
 ↑up			825 0243 10		
 43,95 mm					
ZF; 			840 0046 10		
 ↔			840 0622 10		
40C14 K, 40C14 DK F1CE3481L; (103kW)	09.09-08.11	LUK	 6S-400 OD		600 0274 00
			incl.  ; incl. 		



			SCHAEFFLER
--	---	--	-------------------

IVECO











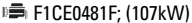
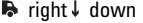

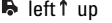









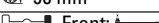



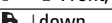



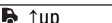





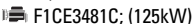
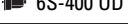

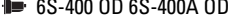

















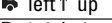





















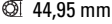





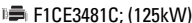
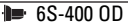



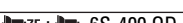



















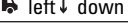







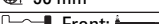

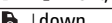

DAILY IV

40C14 K, 40C14 DK F1CE3481L; (103kW)	09.09-08.11		 6S-400 OD	 628 3332 00		
			 6S-400 OD 6S-400A OD	 415 0221 10		
			 6S-400 OD 6S-400A OD	 411 0186 11		
			 A/C	 531 0812 10		
					 A/C	 534 0280 10
					MY 2009	 535 0022 10
					F# F-230846.XX	 535 0103 10
					F# F-550532.XX F-556500.XX	 535 0103 10
					 right ↑ up	 821 0525 10
					 right ↓ down	 821 0527 10
					 left ↑ up	 821 0524 10
					 left ↓ down	 821 0526 10
					 73 mm	  713 6911 20
					 90 mm	  713 6911 10
					 90 mm	  713 6911 30
					 Front;	 818 0483 10
					 Front;	 818 0484 10
					 ↓ down	 825 0242 10
					 44,95 mm	 825 0243 10
					 ↑ up	 825 0243 10
 43,95 mm	 840 0046 10					
ZF;	 840 0622 10					
 ↔	 600 0274 00					
40C14 V, 40C14 V/P F1CE3481L; (103kW)	09.09-08.11					 6S-400 OD incl. ○; incl.
		 6S-400 OD	 415 0221 10			
		 6S-400 OD 6S-400A OD	 411 0186 11			
		 6S-400 OD 6S-400A OD	 411 0186 11			
					 A/C	 531 0812 10
					 A/C	 534 0280 10
					MY 2009	 535 0022 10
					F# F-230846.XX	 535 0103 10
					 right ↑ up	 821 0525 10
					 right ↓ down	 821 0527 10
					 left ↑ up	 821 0524 10
					 left ↓ down	 821 0526 10
					 73 mm	  713 6911 20
					 90 mm	  713 6911 10
					 90 mm	  713 6911 30
					 Front;	 818 0483 10
					 Front;	 818 0484 10
					 ↓ down	 825 0242 10
					 44,95 mm	 825 0243 10
					 ↑ up	 825 0243 10
 43,95 mm	 840 0046 10					
ZF;	 840 0622 10					
 ↔	 600 0274 00					
40C15 40C15 V, 40C15 V/P F1CE0481F; (107kW)	05.06-08.11					 6S-400 OD incl. ○; incl.
		 6S-400 OD	 415 0221 10			
		 6S-400 OD 6S-400A OD	 411 0186 11			
		 6S-400 OD 6S-400A OD	 411 0186 11			
					 A/C	 531 0812 10
					 A/C	 534 0280 10
					F# F-550532.XX F-556500.XX	 535 0103 10
					F# F-559894.XX	 535 0176 10
					 A/C	 FB 4EPK1102
					 A/C	 FB 6PK1218
					 A/C	 538 0575 10
					 right ↑ up	 821 0525 10

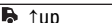

			SCHAEFFLER
--	--	--	-------------------

IVECO**DAILY IV**







































































40C15 40C15 V, 40C15 V/P  F1CE0481F; (107kW)	05.06-08.11	FAG	 right ↓ down		821 0527 10			
			 left ↑ up		821 0524 10			
			 left ↓ down		821 0526 10			
			 73 mm		713 6911 20			
			 90 mm		713 6911 30			
			 Front; 		818 0483 10			
			 Front; 		818 0484 10			
			 ↓down		825 0242 10			
			 44,95 mm					
			 ↑up		825 0243 10			
			 43,95 mm					
			ZF; 		840 0046 10			
					840 0622 10			
			40C17, 40C17 /P  F1CE3481C; (125kW)	07.07-08.11	LUK	 6S-400 OD		628 3191 00
						 6S-400 OD 6S-400A OD		415 0221 10
 6S-400 OD 6S-400A OD		411 0186 11						
	A/C				531 0812 10			
	 # F-550532.XX F-556500.XX				534 0280 10			
	 # F-559894.XX				535 0103 10			
	A/C				535 0176 10			
					FB 4EPK1102			
					FB 6PK1218			
FAG	 right ↑ up				821 0525 10			
	 right ↓ down				821 0527 10			
	 left ↑ up				821 0524 10			
	 left ↓ down				821 0526 10			
	 73 mm				713 6911 20			
	 90 mm				713 6911 10			
	 90 mm		713 6911 30					
	 Front; 		818 0483 10					
	 Front; 		818 0484 10					
	 ↓down		825 0242 10					
	 44,95 mm							
	 ↑up		825 0243 10					
 43,95 mm								
ZF; 		840 0046 10						
		840 0622 10						
40C17 K, 40C17 DK  F1CE3481C; (125kW)	07.07-08.11	LUK	 6S-400 OD		628 3191 00			
			 6S-400 OD 6S-400A OD		415 0221 10			
			 ZF;  6S-400 OD		411 0186 11			
			A/C		531 0812 10			
			 # F-550532.XX F-556500.XX		534 0280 10			
			 # F-559894.XX		535 0103 10			
			A/C		535 0176 10			
					FB 4EPK1102			
					FB 6PK1218			
		FAG	 right ↑ up		821 0525 10			
			 right ↓ down		821 0527 10			
			 left ↑ up		821 0524 10			
			 left ↓ down		821 0526 10			
			 73 mm		713 6911 20			
			 90 mm		713 6911 30			
 Front; 			818 0483 10					
 Front; 			818 0484 10					
 ↓down			825 0242 10					
 44,95 mm								
 ↑up			825 0243 10					
 43,95 mm								
ZF; 		840 0046 10						
		840 0622 10						



			SCHAEFFLER
--	---	--	-------------------

IVECO

DAILY IV











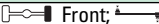







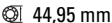

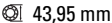



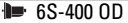



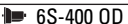

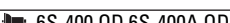

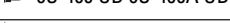





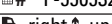

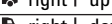

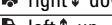

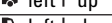





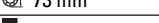









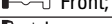







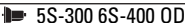

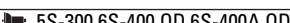

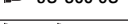

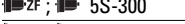

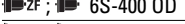





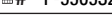

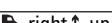

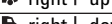

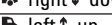







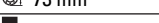













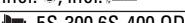

40C17 V, 40C17 V/P F1CE3481C; (125kW)	07.07-08.11		 6S-400 OD	 6S-400 OD 6S-400A OD	 6S-400 OD 6S-400A OD	628 3191 00	415 0221 10	411 0186 11																							
				A/C				531 0812 10	534 0280 10	535 0103 10																					
			F-550532.XX F-556500.XX	F-559894.XX				535 0176 10	FB 4EPK1102	FB 6PK1218																					
		FAG	 right ↑ up	 right ↓ down	 left ↑ up	 left ↓ down	 73 mm	 90 mm	 Front;	 Front;	 ↓down	 44,95 mm	 ↑up	 43,95 mm	ZF;			821 0525 10	821 0527 10	821 0524 10	821 0526 10	713 6911 20	713 6911 30	818 0483 10	818 0484 10	825 0242 10	825 0243 10	840 0046 10	840 0622 10		
			 6S-400 OD	 6S-400 OD 6S-400A OD	 6S-400 OD 6S-400A OD		A/C					F-550532.XX F-556500.XX	A/C						538 0575 10	821 0525 10	821 0527 10	821 0524 10	821 0526 10	713 6911 20	713 6911 30	818 0483 10	818 0484 10	825 0242 10	825 0243 10	840 0046 10	840 0622 10
			FAG	 right ↑ up	 right ↓ down	 left ↑ up	 left ↓ down	 73 mm	 90 mm	 Front;	 Front;	 ↓down	 44,95 mm	 ↑up	 43,95 mm	ZF;			538 0575 10	821 0525 10	821 0527 10	821 0524 10	821 0526 10	713 6911 20	713 6911 30	818 0483 10	818 0484 10	825 0242 10	825 0243 10	840 0046 10	840 0622 10
			 6S-400 OD	 6S-400 OD 6S-400A OD	 6S-400 OD 6S-400A OD		A/C					F-550532.XX F-556500.XX	A/C						538 0575 10	821 0525 10	821 0527 10	821 0524 10	821 0526 10	713 6911 20	713 6911 30	818 0483 10	818 0484 10	825 0242 10	825 0243 10	840 0046 10	840 0622 10
			FAG	 right ↑ up	 right ↓ down	 left ↑ up	 left ↓ down	 73 mm	 90 mm																						

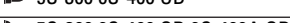

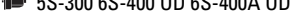
			SCHAEFFLER
--	--	--	-------------------

IVECO











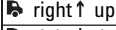

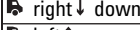

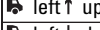

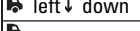







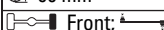



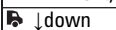



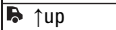





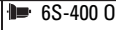

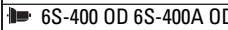

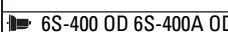







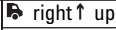

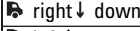

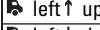

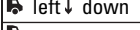





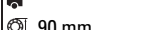

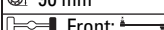



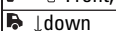



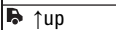





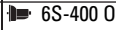

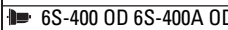

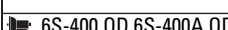















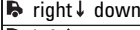

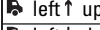

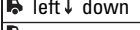





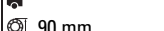

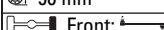



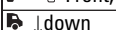



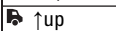



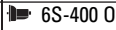

DAILY IV

40C18 V, 40C18 V/P F1CE0481H; (130kW)	05.06-08.11	FAG	 Front; 		818 0483 10	
			 Front; 		818 0484 10	
			 ↓down		825 0242 10	
			 44,95 mm			
			 ↑up		825 0243 10	
			 43,95 mm			
	ZF; 		840 0046 10			
	 ↔		840 0622 10			
	09.09-08.11	LUK	 6S-400 OD incl.  ; incl. 		600 0274 00	
			 6S-400 OD		628 3332 00	
			 6S-400 OD 6S-400A OD		415 0221 10	
			 6S-400 OD 6S-400A OD		411 0186 11	
		INA	A/C		531 0812 10	
					534 0280 10	
# F-550532.XX F-556500.XX				535 0103 10		
FAG			 right ↑ up		821 0525 10	
			 right ↓ down		821 0527 10	
			 left ↑ up		821 0524 10	
	 left ↓ down		821 0526 10			
 73 mm		713 6911 20				
 90 mm		713 6911 30				
 Front; 		818 0483 10				
 Front; 		818 0484 10				
 ↓down		825 0242 10				
 ↑up		825 0243 10				
 43,95 mm						
ZF; 		840 0046 10				
 ↔		840 0622 10				
45C15 F1CE0481F; (107kW)	05.06-08.11	LUK	 5S-300 6S-400 OD incl.  ; incl. 		600 0274 00	
			 5S-300 6S-400 OD		628 3332 00	
			 5S-300 6S-400 OD 6S-400A OD		415 0221 10	
			 ZF;  5S-300		411 0186 11	
			 ZF;  6S-400 OD			
			 ZF;  6S-400A OD			
		INA	A/C		531 0812 10	
					534 0280 10	
			# F-550532.XX F-556500.XX		535 0103 10	
			FAG	 right ↑ up		821 0525 10
				 right ↓ down		821 0527 10
				 left ↑ up		821 0524 10
	 left ↓ down			821 0526 10		
	 73 mm			713 6911 20		
	 90 mm			713 6911 30		
	 Front; 		818 0483 10			
	 Front; 		818 0484 10			
	 ↓down		825 0242 10			
	 ↑up		825 0243 10			
	 43,95 mm					
	ZF; 		840 0046 10			
	 ↔		840 0622 10			
	05.06-08.11	LUK	 5S-300 6S-400 OD incl.  ; incl. 		600 0274 00	
			 5S-300 6S-400 OD		628 3332 00	
 5S-300 6S-400 OD 6S-400A OD				415 0221 10		
 5S-300 6S-400 OD 6S-400A OD				411 0186 11		
INA			A/C		531 0812 10	
					534 0280 10	
		# F-550532.XX F-556500.XX		535 0103 10		
				538 0575 10		

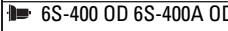

			SCHAEFFLER
--	--	--	-------------------

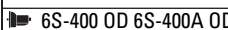
IVECO**DAILY IV**





























































45C15 V F1CE0481F; (107kW)	05.06-08.11	FAG	 right ↑ up		821 0525 10			
			 right ↓ down		821 0527 10			
			 left ↑ up		821 0524 10			
			 left ↓ down		821 0526 10			
			 73 mm		713 6911 20			
			 90 mm		713 6911 30			
			 Front; 		818 0483 10			
			 Front; 		818 0484 10			
			 ↓down		825 0242 10			
			 44,95 mm					
			 ↑up		825 0243 10			
			 43,95 mm					
			ZF; 		840 0046 10			
			 ↔		840 0622 10			
			45C17, 45C17 /P 45C17 V, 45C17 V/P F1CE3481C; (125kW)	07.07-08.11	LUK	 6S-400 OD		628 3191 00
						 6S-400 OD 6S-400A OD		415 0221 10
						 6S-400 OD 6S-400A OD		411 0186 11
 A/C		531 0812 10						
 # F-550532.XX F-556500.XX		534 0280 10						
 # F-550532.XX F-556500.XX		535 0103 10						
FAG	 right ↑ up				821 0525 10			
	 right ↓ down				821 0527 10			
	 left ↑ up				821 0524 10			
	 left ↓ down				821 0526 10			
	 73 mm				713 6911 20			
	 90 mm				713 6911 30			
	 Front; 				818 0483 10			
	 Front; 				818 0484 10			
	 ↓down				825 0242 10			
	 44,95 mm							
	 ↑up				825 0243 10			
	 43,95 mm							
	ZF; 		840 0046 10					
 ↔		840 0622 10						
45C18 45C18, 45C18 /P, 45C18 D, 45C18 D/P F1CE0481H; (130kW)	05.06-08.11	LUK	 6S-400 OD		628 3191 00			
			 6S-400 OD 6S-400A OD		415 0221 10			
			 6S-400 OD 6S-400A OD		411 0186 11			
			 A/C		531 0812 10			
		 # F-550532.XX F-556500.XX		534 0280 10				
		 # F-550532.XX F-556500.XX		535 0103 10				
		 A/C		FB 4EPK1102				
		 # F-550532.XX F-556500.XX		FB 6PK1218				
		 # F-550532.XX F-556500.XX		538 0575 10				
		FAG	 right ↑ up		821 0525 10			
			 right ↓ down		821 0527 10			
			 left ↑ up		821 0524 10			
			 left ↓ down		821 0526 10			
			 73 mm		713 6911 20			
			 90 mm		713 6911 30			
			 Front; 		818 0483 10			
			 Front; 		818 0484 10			
 ↓down			825 0242 10					
 44,95 mm								
 ↑up			825 0243 10					
 43,95 mm								
ZF; 			840 0046 10					
 ↔		840 0622 10						
50C14, 50C14 /P F1CE3481L; (103kW)	09.09-08.11	LUK	 6S-400 OD		600 0274 00			
			 6S-400 OD		628 3332 00			
			 6S-400 OD 6S-400A OD		415 0221 10			
			 6S-400 OD 6S-400A OD		411 0186 11			
			 6S-400 OD 6S-400A OD					



			<p>SCHAEFFLER</p>
--	---	--	--------------------------

IVECO

DAILY IV





























































































































<p>50C14, 50C14 /P F1CE3481L; (103kW)</p>	<p>09.09-08.11</p>	<p> FAG</p>	<p>A/C  531 0812 10  534 0280 10  535 0103 10  821 0525 10  821 0527 10  821 0524 10  821 0526 10  713 6911 20  713 6911 30  818 0483 10  818 0484 10  825 0242 10  825 0243 10  840 0046 10  840 0622 10</p>	
<p>50C14 G, 50C14 G/P, 50C14 GD, 50C14 GD/P F1CE0441A; (100kW)</p>	<p>07.07-08.11</p>	<p> FAG</p>	<p>6S-400 OD incl. ; incl.  600 0274 00  628 3332 00  415 0221 10  411 0186 11 A/C  531 0812 10  534 0280 10  535 0103 10 A/C  FB 4EPK1102  FB 6PK1218  821 0525 10  821 0527 10  821 0524 10  821 0526 10  713 6911 20  713 6911 30  818 0483 10  818 0484 10  825 0242 10  825 0243 10  840 0046 10  840 0622 10</p>	
<p>50C14 GV, 50C14 GV/P F1CE0441A; (100kW)</p>	<p>07.07-08.11</p>	<p> FAG</p>	<p>6S-400 OD incl. ; incl.  600 0274 00  628 3332 00  415 0221 10  411 0186 11 A/C  531 0812 10  534 0280 10  535 0103 10 A/C  FB 4EPK1102  FB 6PK1218  821 0525 10  821 0527 10  821 0524 10  821 0526 10  713 6911 20  713 6911 30  818 0483 10  818 0484 10  825 0242 10  44,95 mm</p>	



			SCHAEFFLER
--	--	--	-------------------

IVECO











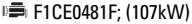



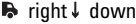











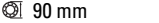
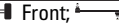

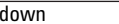



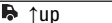











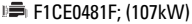

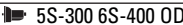



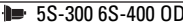



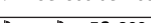
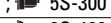

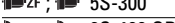
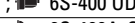

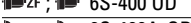
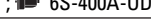





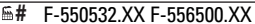

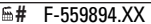





















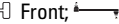

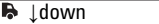



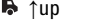











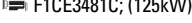

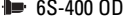









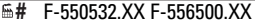

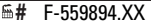











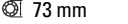



DAILY IV

50C14 GV, 50C14 GV/P F1CE0441A; (100kW)	07.07-08.11	FAG	 ↑ up	 43,95 mm		825 0243 10
			ZF; 		840 0046 10	
					840 0622 10	
			LUK	 6S-400 OD incl.  ; incl. 		600 0274 00
				 6S-400 OD		628 3332 00
				 6S-400 OD		415 0221 10
				 6S-400A OD		411 0186 11
				 6S-400 OD		411 0186 11
				 6S-400A OD		411 0186 11
				 6S-400A OD		411 0186 11
			INA	A/C		531 0812 10
						534 0280 10
				## F-550532.XX F-556500.XX		535 0103 10
			FAG	 right ↑ up		821 0525 10
				 right ↓ down		821 0527 10
 left ↑ up		821 0524 10				
 left ↓ down		821 0526 10				
 73 mm		713 6911 20				
 90 mm		713 6911 30				
 Front; 		818 0483 10				
 Front; 		818 0484 10				
 ↓ down		825 0242 10				
 44,95 mm		825 0242 10				
 ↑ up		825 0243 10				
 43,95 mm		825 0243 10				
ZF; 		840 0046 10				
		840 0622 10				
50C14 V, 50C14 V/P F1CE3481L; (103kW)	09.09-08.11	LUK		 6S-400 OD incl.  ; incl. 		600 0274 00
			 6S-400 OD		628 3332 00	
			 6S-400 OD 6S-400A OD		415 0221 10	
			 6S-400 OD 6S-400A OD		411 0186 11	
			INA	A/C		531 0812 10
						534 0280 10
				## F-550532.XX F-556500.XX		535 0103 10
			FAG	 right ↑ up		821 0525 10
				 right ↓ down		821 0527 10
				 left ↑ up		821 0524 10
				 left ↓ down		821 0526 10
				 73 mm		713 6911 20
				 90 mm		713 6911 30
				 Front; 		818 0483 10
				 Front; 		818 0484 10
 ↓ down		825 0242 10				
 44,95 mm		825 0242 10				
 ↑ up		825 0243 10				
 43,95 mm		825 0243 10				
ZF; 		840 0046 10				
		840 0622 10				
50C15 F1CE0481F; (107kW)	05.06-08.11	LUK	 5S-300 6S-400 OD incl.  ; incl. 		600 0274 00	
			 5S-300 6S-400 OD		628 3332 00	
			 5S-300 6S-400 OD 6S-400A OD		415 0221 10	
			 5S-300 6S-400 OD 6S-400A OD		411 0186 11	
			 5S-300		411 0186 11	
			 6S-400 OD		411 0186 11	
			 6S-400A OD		411 0186 11	
			INA	A/C		531 0812 10
						534 0280 10
				## F-550532.XX F-556500.XX		535 0103 10
			## F-559894.XX		535 0176 10	
			A/C		FB 4EPK1102	
					FB 6PK1218	



			SCHAEFFLER
--	--	--	-------------------

IVECO**DAILY IV**







































































































































50C15  F1CE0481F; (107kW)	05.06-08.11	 FAG	 right ↑ up		538 0575 10			
			 right ↓ down		821 0525 10			
			 left ↑ up		821 0527 10			
			 left ↓ down		821 0524 10			
					821 0526 10			
			 73 mm		713 6911 20			
			 90 mm		713 6911 30			
			 Front; 		818 0483 10			
			 Front; 		818 0484 10			
			 ↓down		825 0242 10			
			 44,95 mm		825 0243 10			
			 ↑up		825 0243 10			
			 43,95 mm		825 0243 10			
			ZF; 		840 0046 10			
					840 0622 10			
					600 0274 00			
			50C15 V, 50C15 V/P  F1CE0481F; (107kW)	05.06-08.11	 LUK	 5S-300 6S-400 OD incl.  ; incl. 		628 3332 00
						 5S-300 6S-400 OD		628 3332 00
						 5S-300 6S-400 OD 6S-400A OD		415 0221 10
						 ZF;  5S-300		411 0186 11
 ZF;  6S-400 OD		411 0186 11						
 ZF;  6S-400A-OD		411 0186 11						
 A/C		531 0812 10						
						534 0280 10		
	 # F-550532.XX F-556500.XX					535 0103 10		
	 # F-559894.XX					535 0176 10		
A/C		FB 4EPK1102						
						FB 6PK1218		
	 FAG					538 0575 10		
	 right ↑ up					821 0525 10		
 right ↓ down		821 0527 10						
 left ↑ up		821 0524 10						
 left ↓ down		821 0526 10						
		713 6911 20						
 73 mm		713 6911 20						
 90 mm		713 6911 30						
 Front; 		818 0483 10						
 Front; 		818 0484 10						
 ↓down		825 0242 10						
 44,95 mm		825 0242 10						
 ↑up		825 0243 10						
 43,95 mm		825 0243 10						
ZF; 		840 0046 10						
		840 0622 10						
		628 3191 00						
50C17, 50C17/P  F1CE3481C; (125kW)	07.07-08.11	 LUK	 6S-400 OD		628 3191 00			
			 6S-400 OD 6S-400A OD		415 0221 10			
			 6S-400 OD 6S-400A OD		411 0186 11			
			 A/C		531 0812 10			
						534 0280 10		
				 # F-550532.XX F-556500.XX		535 0103 10		
				 # F-559894.XX		535 0176 10		
			A/C		FB 4EPK1102			
						FB 6PK1218		
				 FAG		821 0525 10		
				 right ↑ up		821 0525 10		
			 right ↓ down		821 0527 10			
			 left ↑ up		821 0524 10			
			 left ↓ down		821 0526 10			
					713 6911 20			
			 73 mm		713 6911 20			
			 90 mm		713 6911 30			
			 Front; 		818 0483 10			
			 Front; 		818 0484 10			



			SCHAEFFLER
--	---	--	-------------------

IVECO











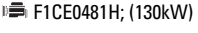
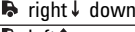

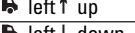

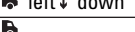

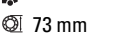



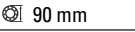

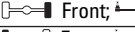

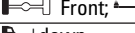

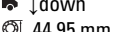
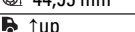

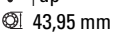

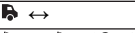

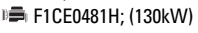











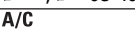







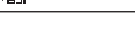

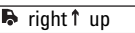

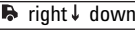

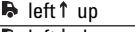

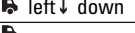

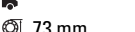

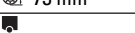

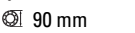

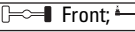

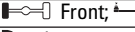

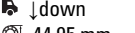
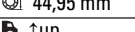

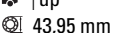
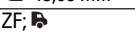



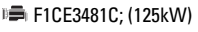



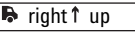

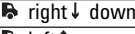

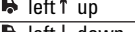

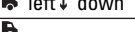



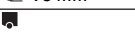

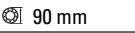

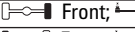

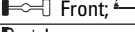

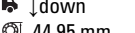
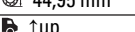

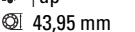
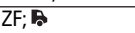

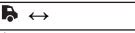

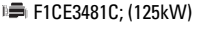
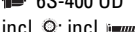

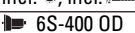

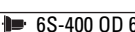

DAILY IV

50C17, 50C17 /P F1CE3481C; (125kW)	07.07-08.11	FAG	 ↓down	 44,95 mm		825 0242 10			
			 ↑up	 43,95 mm		825 0243 10			
			ZF; 			840 0046 10			
						840 0622 10			
				6S-400 OD		628 3191 00			
				6S-400 OD 6S-400A OD		415 0221 10			
			A/C		6S-400 OD		411 0186 11		
					ZF; 		411 0186 11		
					ZF; 		411 0186 11		
					A/C		531 0812 10		
							534 0280 10		
					# F-550532.XX F-556500.XX		535 0103 10		
FAG			right ↑ up		821 0525 10				
			right ↓ down		821 0527 10				
			left ↑ up		821 0524 10				
			left ↓ down		821 0526 10				
			73 mm		713 6911 20				
			90 mm		713 6911 30				
			Front; 		818 0483 10				
			Front; 		818 0484 10				
			↓down		825 0242 10				
			44,95 mm		825 0243 10				
			↑up		825 0243 10				
			43,95 mm		825 0243 10				
		ZF; 			840 0046 10				
					840 0622 10				
			6S-400 OD		6S-400 OD		628 3191 00		
					6S-400 OD 6S-400A OD		415 0221 10		
					6S-400 OD 6S-400A OD		411 0186 11		
					A/C		A/C		531 0812 10
									534 0280 10
							# F-550532.XX F-556500.XX		535 0103 10
			# F-559894.XX				535 0176 10		
			A/C				FB 4EPK1102		
							FB 6PK1218		
		FAG			right ↑ up		821 0525 10		
	right ↓ down				821 0527 10				
	left ↑ up				821 0524 10				
	left ↓ down				821 0526 10				
	73 mm				713 6911 20				
	90 mm				713 6911 30				
	Front; 				818 0483 10				
	Front; 				818 0484 10				
	↓down				825 0242 10				
	44,95 mm				825 0243 10				
	↑up				825 0243 10				
	43,95 mm				825 0243 10				
ZF; 					840 0046 10				
					840 0622 10				
	6S-400 OD				6S-400 OD		628 3191 00		
					6S-400 OD 6S-400A OD		415 0221 10		
					6S-400 OD 6S-400A OD		411 0186 11		
					A/C		A/C		531 0812 10
									534 0280 10
							# F-550532.XX F-556500.XX		535 0103 10
	A/C						FB 4EPK1102		
							FB 6PK1218		
							538 0575 10		
FAG					right ↑ up		821 0525 10		

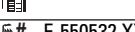

			SCHAEFFLER
--	--	--	-------------------

IVECO**DAILY IV**































































50C18  F1CE0481H; (130kW)	05.06-08.11	FAG	 right ↓ down		821 0527 10			
			 left ↑ up		821 0524 10			
			 left ↓ down		821 0526 10			
			 73 mm		713 6911 20			
			 90 mm		713 6911 30			
			 Front; 		818 0483 10			
			 Front; 		818 0484 10			
			 ↓down		825 0242 10			
			 44,95 mm					
			 ↑up		825 0243 10			
			 43,95 mm					
			ZF; 		840 0046 10			
			 ↔		840 0622 10			
			50C18 V, 50C18 V/P  F1CE0481H; (130kW)	05.06-08.11	LUK	 ZF;  6S-400 OD		628 3191 00
						 ZF;  6S-400 OD		415 0221 10
 ZF;  6S-400A OD		411 0186 11						
 ZF;  6S-400 OD								
 ZF;  6S-400A OD								
	A/C				531 0812 10			
					534 0280 10			
	# F-550532.XX F-556500.XX				535 0103 10			
	A/C				FB 4EPK1102			
					FB 6PK1218			
					538 0575 10			
FAG	 right ↑ up				821 0525 10			
	 right ↓ down				821 0527 10			
	 left ↑ up				821 0524 10			
	 left ↓ down				821 0526 10			
	 73 mm				713 6911 20			
	 90 mm				713 6911 30			
	 Front; 				818 0483 10			
	 Front; 				818 0484 10			
	 ↓down				825 0242 10			
	 44,95 mm							
	 ↑up		825 0243 10					
	 43,95 mm							
	ZF; 		840 0046 10					
	 ↔		840 0622 10					
55C17  F1CE3481C; (125kW)	08.07-03.12		# F-550532.XX F-556500.XX		535 0103 10			
			# F-559894.XX		535 0176 10			
		FAG	 right ↑ up		821 0525 10			
			 right ↓ down		821 0527 10			
			 left ↑ up		821 0524 10			
			 left ↓ down		821 0526 10			
			 73 mm		713 6911 20			
			 90 mm		713 6911 30			
			 Front; 		818 0483 10			
			 Front; 		818 0484 10			
			 ↓down		825 0242 10			
			 44,95 mm					
			 ↑up		825 0243 10			
			 43,95 mm					
			ZF; 		840 0046 10			
			 ↔		840 0622 10			
55S17 W, 55S17 WD  F1CE3481C; (125kW)	07.07-08.11	LUK	 6S-400 OD		600 0274 00			
			incl.  ; incl. 		628 3332 00			
			 6S-400 OD		415 0221 10			
			 ZF;  6S-400 OD		411 0186 11			
			 ZF;  6S-400A OD					
			A/C		531 0812 10			
					534 0280 10			
			# F-550532.XX F-556500.XX		535 0103 10			



			SCHAEFFLER
--	--	--	-------------------

IVECO

















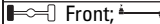

















































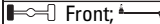







































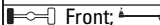





DAILY IV

55S17 W, 55S17 WD FICE3481C; (125kW)	07.07-08.11		# F-559894.XX	 535 0176 10						
			A/C	 FB 4EPK1102						
			 FB 6PK1218	 821 0525 10						
			 821 0527 10	 821 0524 10						
			 821 0526 10	 713 6911 30						
			 90 mm	 713 6911 30						
			 90 mm	 818 0483 10						
			 Front;	 818 0484 10						
			 Front;	 825 0242 10						
			 ↓down	 825 0243 10						
			 44,95 mm	 840 0046 10						
			 ↑up	 840 0622 10						
			 43,95 mm	 535 0103 10						
			ZF;	 713 6911 30						
			 ↔	 713 6911 30						
			55S18W FICE0481H; (130kW)	06.06-08.11		# F-550532.XX F-556500.XX	 535 0103 10			
						A/C	 713 6911 30			
						 90 mm	 713 6911 30			
 90 mm	 600 0274 00									
60C14, 60C14 /P FICE3481L; (103kW)	09.09-08.11					6S-400 OD incl. ○; incl.	 628 3332 00			
						6S-400 OD	 415 0221 10			
						6S-400 OD 6S-400A OD	 411 0186 11			
						6S-400 OD 6S-400A OD	 531 0812 10			
						60C14 K, 60C14 DK FICE3481L; (103kW)	09.09-08.11		A/C	 534 0280 10
										 535 0103 10
									# F-550532.XX F-556500.XX	 FB 4EPK1102
									A/C	 FB 6PK1218
										 821 0525 10
										 821 0527 10
										 821 0524 10
										 821 0526 10
										 713 6911 30
									 90 mm	 713 6910 90
			 Front;	 818 0483 10						
			 Front;	 818 0484 10						
			↓down	825 0242 10						
			44,95 mm	825 0243 10						
↑up	840 0046 10									
43,95 mm	840 0622 10									
ZF;	600 0274 00									
↔	628 3332 00									
6S-400 OD	415 0221 10									
6S-400 OD	411 0186 11									
6S-400 OD 6S-400A OD	531 0812 10									
ZF; 6S-400 OD	534 0280 10									
ZF; 6S-400A OD	535 0103 10									
A/C	FB 4EPK1102									
	FB 6PK1218									
	821 0525 10									
	821 0527 10									
	821 0524 10									
	821 0526 10									
	713 6911 30									
90 mm										



			SCHAEFFLER
--	--	--	-------------------

IVECO**DAILY IV**































































































































	60C14 K, 60C14 DK F1CE3481L; (103kW)	09.09-08.11	FAG		 Set	713 6910 90
				 Front; 		818 0483 10
				 Front; 		818 0484 10
				 ↓down		825 0242 10
				 44,95 mm		
				 ↑up		825 0243 10
				 43,95 mm		
				ZF; 		840 0046 10
				 ↔		840 0622 10
	60C15 F1CE0481F; (107kW)	05.06-08.11	LUK			S6-400 OD 5S-300 incl.  ; incl. 
					5S-300 6S-400 OD	628 3332 00
				 ZF; 	5S-300	415 0221 10
				 ZF; 	6S-400 OD	
				 ZF; 	6S-400A OD	
				 ZF; 	5S-300	411 0186 11
				 ZF; 	6S-400 OD	
				 ZF; 	6S-400A OD	
				A/C		531 0812 10
						534 0280 10
				 # F-550532.XX F-556500.XX		535 0103 10
				A/C		FB 4EPK1102
						FB 6PK1218
						538 0575 10
			FAG		right ↑ up	821 0525 10
					right ↓ down	821 0527 10
					left ↑ up	821 0524 10
					left ↓ down	821 0526 10
					90 mm	 Set
						 Set
				 Front; 		818 0483 10
				 Front; 		818 0484 10
				 ↓down		825 0242 10
				 44,95 mm		
				 ↑up		825 0243 10
				 43,95 mm		
				ZF; 		840 0046 10
				 ↔		840 0622 10
60C15, 60C15/P, 60C15 D, 60C15 D/P 60C15 V F1CE0481F; (107kW)	05.06-08.11	LUK			5S-300 6S-400 OD incl.  ; incl. 	600 0274 00
					5S-300 6S-400 OD	628 3332 00
					5S-300 6S-400 OD 6S-400A OD	415 0221 10
					5S-300 6S-400 OD 6S-400A OD	411 0186 11
				A/C		531 0812 10
						534 0280 10
				 # F-550532.XX F-556500.XX		535 0103 10
				A/C		FB 4EPK1102
						FB 6PK1218
						538 0575 10
			FAG		right ↑ up	821 0525 10
					right ↓ down	821 0527 10
					left ↑ up	821 0524 10
					left ↓ down	821 0526 10
					90 mm	 Set
						 Set
				 Front; 		818 0483 10
				 Front; 		818 0484 10
				 ↓down		825 0242 10
				 44,95 mm		
				 ↑up		825 0243 10
				 43,95 mm		
				ZF; 		840 0046 10
				 ↔		840 0622 10
60C17, 60C17/P F1CE3481C; (125kW)	07.07-08.11	LUK			6S-400 OD	628 3191 00
					6S-400 OD 6S-400A OD	415 0221 10



			SCHAEFFLER
--	---	--	-------------------

IVECO

DAILY IV











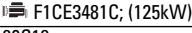

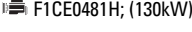



















































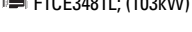













































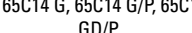

















60C17, 60C17 /P  F1CE3481C; (125kW)	07.07-08.11	 	A/C		411 0186 11		
				531 0812 10			
				534 0280 10			
				535 0103 10			
			A/C		FB 4EPK1102		
				FB 6PK1218			
			FAG	 right ↑ up		821 0525 10	
				 right ↓ down		821 0527 10	
				 left ↑ up		821 0524 10	
				 left ↓ down		821 0526 10	
		 90 mm		 Set	713 6911 30		
		 90 mm		 Set	713 6910 90		
		 Front; 			818 0483 10		
		 Front; 			818 0484 10		
		 ↓down			825 0242 10		
		 44,95 mm					
		 ↑up		825 0243 10			
		 43,95 mm					
		ZF; 		840 0046 10			
				840 0622 10			
		60C17 K, 60C17 DK  F1CE3481C; (125kW)	07.07-08.11		 6S-400 OD		628 3191 00
					 6S-400 OD 6S-400A OD		415 0221 10
					 ZF;  6S-400 OD		411 0186 11
					 ZF;  6S-400A OD		
						A/C	
	534 0280 10						
	535 0103 10						
A/C				FB 4EPK1102			
	FB 6PK1218						
FAG	 right ↑ up					821 0525 10	
	 right ↓ down					821 0527 10	
	 left ↑ up					821 0524 10	
	 left ↓ down					821 0526 10	
	 90 mm			 Set		713 6911 30	
	 90 mm			 Set	713 6910 90		
	 Front; 				818 0483 10		
	 Front; 				818 0484 10		
	 ↓down				825 0242 10		
	 44,95 mm						
 ↑up				825 0243 10			
 43,95 mm							
ZF; 				840 0046 10			
				840 0622 10			
60C17 V, 60C17 V/P  F1CE3481C; (125kW)	07.07-08.11				 6AS-400 OD		628 3191 00
					 6S-400 OD 6S-400A OD		415 0221 10
		 6S-400 OD 6S-400A OD			411 0186 11		
			A/C			531 0812 10	
					534 0280 10		
					535 0103 10		
			A/C		FB 4EPK1102		
				FB 6PK1218			
			FAG	 right ↑ up		821 0525 10	
				 right ↓ down		821 0527 10	
				 left ↑ up		821 0524 10	
				 left ↓ down		821 0526 10	
				 90 mm	 Set	713 6911 30	
		 90 mm		 Set	713 6910 90		
		 Front; 			818 0483 10		
		 Front; 			818 0484 10		
		 ↓down			825 0242 10		
		 44,95 mm					
		 ↑up		825 0243 10			
		 43,95 mm					
		ZF;		840 0046 10			



			SCHAEFFLER
--	--	--	-------------------

IVECO











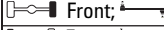

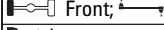































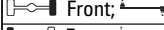



































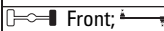



















DAILY IV

60C17 V, 60C17 V/P  F1CE3481C; (125kW)	07.07-08.11	FAG	 ↔		840 0622 10
60C18  F1CE0481H; (130kW)	05.06-08.11	LUK	 6S-400 OD incl.  ; incl. 		600 0274 00
			 6S-400 OD		628 3332 00
			 6S-400 OD 6S-400A OD		415 0221 10
			 6S-400 OD 6S-400A OD		411 0186 11
			A/C		531 0812 10
			 		534 0280 10
			# F-550532.XX F-556500.XX		535 0103 10
			A/C		FB 4EPK1102
			 		FB 6PK1218
					538 0575 10
		FAG	 right ↑ up		821 0525 10
			 right ↓ down		821 0527 10
			 left ↑ up		821 0524 10
			 left ↓ down		821 0526 10
			 90 mm	 Set	713 6911 30
				 Set	713 6910 90
			 Front; 		818 0483 10
			 Front; 		818 0484 10
			 ↓down		825 0242 10
			 44,95 mm		825 0243 10
			 ↑up		825 0243 10
			 43,95 mm		840 0046 10
			ZF; 		840 0622 10
			 ↔		600 0274 00
65C14, 65C14 /P  F1CE3481L; (103kW)	09.09-08.11	LUK	 6S-400 OD incl.  ; incl. 		628 3332 00
			 6S-400 OD		415 0221 10
			 6S-400 OD 6S-400A OD		411 0186 11
			 ZF;  6S-400 OD		531 0812 10
			 ZF;  6S-400A OD		534 0280 10
			A/C		535 0103 10
			 		821 0525 10
			# F-550532.XX F-556500.XX		821 0527 10
			A/C		821 0524 10
			 		821 0526 10
				 Set	713 6911 30
			 90 mm	 Set	713 6910 90
			 Front; 		818 0483 10
			 Front; 		818 0484 10
			 ↓down		825 0242 10
			 44,95 mm		825 0243 10
			 ↑up		840 0046 10
			 43,95 mm		840 0622 10
			ZF; 		628 3332 00
			 ↔		415 0221 10
65C14 G, 65C14 G/P, 65C14 GD, 65C14 GD/P  F1CE0441A; (100kW)	07.07-08.11	LUK	 6S-400 OD 		411 0186 11
			 6S-400 OD 6S-400A OD		415 0221 10
					411 0186 11
			A/C		531 0812 10
			 		534 0280 10
			# F-550532.XX F-556500.XX		535 0103 10
			A/C		FB 4EPK1102
			 		FB 6PK1218
					821 0525 10
					821 0527 10
					821 0524 10
					821 0526 10
				 Set	713 6911 30
			 90 mm	 Set	713 6910 90



			SCHAEFFLER
--	---	--	-------------------











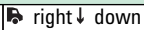



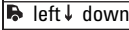







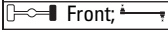



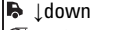



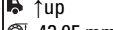





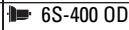

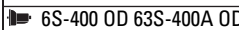











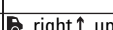

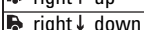

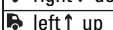

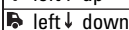













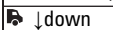



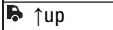





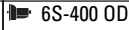

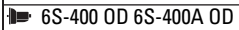











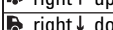

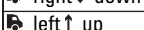

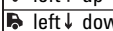









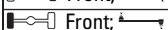



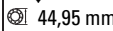



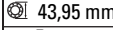

IVECO

DAILY IV				
65C14 G, 65C14 G/P, 65C14 GD, 65C14 GD/P FICE0441A; (100kW)	07.07-08.11	FAG	 713 6910 90	
			 Front; 	
			 Front; 	
			 ↓down  44,95 mm	
			 ↑up  43,95 mm	
			ZF; 	
			 ↔	
			 840 0046 10	
			 840 0622 10	
			 818 0483 10	
			 818 0484 10	
			65C14 K, 65C14 DK FICE3481L; (103kW)	09.09-08.11
 415 0221 10				
 411 0186 11				
	A/C	 531 0812 10		
		 534 0280 10		
	# F-550532.XX F-556500.XX	 535 0103 10		
FAG	 right ↑ up	 821 0525 10		
	 right ↓ down	 821 0527 10		
	 left ↑ up	 821 0524 10		
	 left ↓ down	 821 0526 10		
	 90 mm	 713 6911 30		
	 713 6910 90			
	 Front; 	 818 0483 10		
	 Front; 	 818 0484 10		
	 ↓down  44,95 mm	 825 0242 10		
	 ↑up  43,95 mm	 825 0243 10		
	ZF; 	 840 0046 10		
	 ↔	 840 0622 10		
65C14 V, 65C14 V/P FICE3481L; (103kW)	09.09-08.11	LUK	 600 0274 00	
			 628 3332 00	
			 415 0221 10	
			 411 0186 11	
			A/C	 531 0812 10
				 534 0280 10
			# F-550532.XX F-556500.XX	 535 0103 10
			# F-550532.XX F-556500.XX	 535 0103 10
		FAG	 right ↑ up	 821 0525 10
			 right ↓ down	 821 0527 10
			 left ↑ up	 821 0524 10
			 left ↓ down	 821 0526 10
 90 mm	 713 6911 30			
 713 6910 90				
 Front; 	 818 0483 10			
 Front; 	 818 0484 10			
 ↓down  44,95 mm	 825 0242 10			
 ↑up  43,95 mm	 825 0243 10			
ZF; 	 840 0046 10			
 ↔	 840 0622 10			
65C15 FICE0481F; (107kW)	05.06-08.11	LUK	 600 0274 00	
			 628 3332 00	
			 415 0221 10	
			 411 0186 11	
			A/C	 531 0812 10
				 534 0280 10
			# F-550532.XX F-556500.XX	 535 0103 10
			# F-559894.XX	 535 0176 10
		FAG	A/C	 FB 4EPK1102
				 FB 6PK1218
				 538 0575 10
			 right ↑ up	 821 0525 10

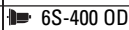

			SCHAEFFLER
--	--	--	-------------------

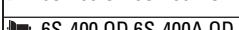
IVECO**DAILY IV**





























































































































 <p>65C15 F1CE0481F; (107kW)</p>	05.06-08.11	FAG	 right ↓ down		821 0527 10			
			 left ↑ up		821 0524 10			
			 left ↓ down		821 0526 10			
			 90 mm		713 6911 30			
			 90 mm		713 6910 90			
			 Front; 		818 0483 10			
			 Front; 		818 0484 10			
			 ↓down		825 0242 10			
			 44,95 mm		825 0243 10			
			 ↑up		825 0243 10			
			 43,95 mm		825 0243 10			
			ZF; 		840 0046 10			
					840 0622 10			
			<p>65C15, 65C15 /P, 65C15 D, 65C15 D/P F1CE0481F; (107kW)</p>	05.06-08.11	LUK	 6S-400 OD		628 3332 00
						 6S-400 OD 6S-400A OD		415 0221 10
 6S-400 OD 6S-400A OD		411 0186 11						
	A/C				531 0812 10			
					534 0280 10			
	# F-550532.XX F-556500.XX				535 0103 10			
	# F-559894.XX				535 0176 10			
	A/C				FB 4EPK1102			
					FB 6PK1218			
FAG	 right ↑ up				538 0575 10			
	 right ↓ down				821 0525 10			
	 left ↑ up				821 0524 10			
	 left ↓ down				821 0526 10			
	 90 mm				713 6911 30			
	 90 mm				713 6910 90			
	 Front; 		818 0483 10					
	 Front; 		818 0484 10					
	 ↓down		825 0242 10					
	 44,95 mm		825 0243 10					
	 ↑up		825 0243 10					
	 43,95 mm		825 0243 10					
ZF; 		840 0046 10						
		840 0622 10						
<p>65C17, 65C17 /P F1CE3481C; (125kW)</p>	07.07-08.11	LUK	 6S-400 OD		628 3191 00			
			 6S-400 OD 6S-400A OD		415 0221 10			
			 6S-400 OD 6S-400A OD		411 0186 11			
			A/C		531 0812 10			
					534 0280 10			
			# F-550532.XX F-556500.XX		535 0103 10			
			# F-559894.XX		535 0176 10			
			A/C		FB 4EPK1102			
					FB 6PK1218			
		FAG	 right ↑ up		821 0525 10			
			 right ↓ down		821 0527 10			
			 left ↑ up		821 0524 10			
			 left ↓ down		821 0526 10			
			 90 mm		713 6911 30			
			 90 mm		713 6910 90			
 Front; 			818 0483 10					
 Front; 			818 0484 10					
 ↓down			825 0242 10					
 44,95 mm			825 0243 10					
 ↑up			825 0243 10					
 43,95 mm			825 0243 10					
ZF; 		840 0046 10						
		840 0622 10						
<p>65C17 K, 65C17 DK, 65C17KK F1CE3481C; (125kW)</p>	07.07-08.11	LUK	 6S-400 OD		628 3191 00			
			 6S-400 OD 6S-400A OD		415 0221 10			
			 6S-400 OD 6S-400A OD		411 0186 11			



			SCHAEFFLER
--	--	--	-------------------

IVECO











































































































































DAILY IV

<p>65C17 K, 65C17 DK, 65C17KK  F1CE3481C; (125kW)</p>	<p>07.07-08.11</p>	<p></p>	<p>A/C     A/C            </p>	<p> 531 0812 10  534 0280 10  535 0103 10  535 0176 10  FB 4EPK1102  FB 6PK1218  821 0525 10  821 0527 10  821 0524 10  821 0526 10   713 6911 30   713 6910 90  818 0483 10  818 0484 10  825 0242 10  825 0243 10  840 0046 10  840 0622 10</p>
<p>65C17 V, 65C17 V/P  F1CE3481C; (125kW)</p>	<p>07.07-08.11</p>	<p></p> <p></p>	<p> 6AS-400 OD  6S-400 OD 6S-400A OD  6S-400 OD 6S-400A OD A/C     A/C            </p>	<p> 628 3191 00  415 0221 10  411 0186 11  531 0812 10  534 0280 10  535 0103 10  535 0176 10  FB 4EPK1102  FB 6PK1218  821 0525 10  821 0527 10  821 0524 10  821 0526 10   713 6911 30   713 6910 90  818 0483 10  818 0484 10  825 0242 10  825 0243 10  840 0046 10  840 0622 10</p>
<p>65C18  F1CE0481H; (130kW)</p>	<p>05.06-08.11</p>	<p></p> <p></p>	<p> 6S-400 OD  6S-400 OD 6S-400A OD  6S-400 OD 6S-400A OD A/C     A/C          </p>	<p> 628 3191 00  415 0221 10  411 0186 11  531 0812 10  534 0280 10  535 0103 10  FB 4EPK1102  FB 6PK1218  538 0575 10  821 0525 10  821 0527 10  821 0524 10  821 0526 10   713 6911 30   713 6910 90  818 0483 10  818 0484 10  825 0242 10  825 0243 10</p>



			SCHAEFFLER
--	--	--	-------------------

IVECO**DAILY IV**































































































































65C18 F1CE0481H; (130kW)	05.06-08.11	FAG	ZF; 		840 0046 10	
					840 0622 10	
70C14, 70C14 /P F1CE3481L; (103kW)	09.09-08.11	LUK	 6S-400 OD		600 0274 00	
			incl.  ; incl. 		628 3332 00	
			 6S-400 OD		415 0221 10	
			 6S-400 OD 6S-400A OD		411 0186 11	
			 ZF;  6S-400 OD			
		 ZF;  6S-400A OD				
			A/C		531 0812 10	
					534 0280 10	
			# F-550532.XX F-556500.XX		535 0103 10	
			FAG	 right ↑ up		821 0525 10
				 right ↓ down		821 0527 10
		 left ↑ up			821 0524 10	
		 left ↓ down			821 0526 10	
		 90 mm			713 6911 30	
		FAG	 		713 6910 90	
			 Front; 		818 0483 10	
			 Front; 		818 0484 10	
			 ↓down		825 0242 10	
			 44,95 mm			
			 ↑up		825 0243 10	
 43,95 mm						
ZF; 			840 0046 10			
			840 0622 10			
70C14 K, 70C14 DK, 70C14 KK F1CE3481L; (103kW)	09.09-08.11		LUK	 ZF;  6S-400 OD		600 0274 00
		incl.  ; incl. 			628 3332 00	
		 ZF;  6S-400 OD			415 0221 10	
		 ZF;  6S-400A OD			411 0186 11	
		 ZF;  6S-400 OD				
		 ZF;  6S-400A OD				
			A/C		531 0812 10	
					534 0280 10	
			# F-550532.XX F-556500.XX		535 0103 10	
			FAG	 right ↑ up		821 0525 10
				 right ↓ down		821 0527 10
		 left ↑ up			821 0524 10	
		 left ↓ down			821 0526 10	
		 90 mm			713 6911 30	
		FAG	 		713 6910 90	
			 Front; 		818 0483 10	
			 Front; 		818 0484 10	
			 ↓down		825 0242 10	
			 44,95 mm			
			 ↑up		825 0243 10	
 43,95 mm						
ZF; 			840 0046 10			
			840 0622 10			
70C14 V, 70C14 V/P F1CE3481L; (103kW)	09.09-08.11		LUK	 6S-400 OD		628 3191 00
		 6S-400 OD 6S-400A OD			415 0221 10	
		 6S-400 OD 6S-400A OD			411 0186 11	
			A/C		531 0812 10	
					534 0280 10	
			# F-550532.XX F-556500.XX		535 0103 10	
			FAG	 right ↑ up		821 0525 10
				 right ↓ down		821 0527 10
		 left ↑ up			821 0524 10	
		 left ↓ down			821 0526 10	
		 90 mm			713 6911 30	
		FAG	 		713 6910 90	
			 Front; 		818 0483 10	
			 Front; 		818 0484 10	



			SCHAEFFLER
--	--	--	-------------------

IVECO

DAILY IV















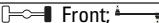

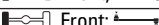

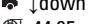

70C14 V, 70C14 V/P F1CE3481L; (103kW)	09.09-08.11	FAG	 ↓ down  44,95 mm		825 0242 10
			 ↑ up  43,95 mm		825 0243 10
			ZF; 		840 0046 10
					840 0622 10
			 6S-400 OD incl.  		600 0274 00
			 6S-400 OD		628 3332 00
			 6S-400 OD 6S-400A OD		415 0221 10
			 6S-400 OD 6S-400A OD		411 0186 11
			A/C		531 0812 10
					534 0280 10
 # F-550532.XX F-556500.XX		535 0103 10			
 # F-559894.XX		535 0176 10			
 right ↑ up		821 0525 10			
 right ↓ down		821 0527 10			
 left ↑ up		821 0524 10			
 left ↓ down		821 0526 10			
 90 mm		713 6911 30			
		713 6910 90			
 Front; 		818 0483 10			
 Front; 		818 0484 10			
 ↓ down  44,95 mm		825 0242 10			
 ↑ up  43,95 mm		825 0243 10			
ZF; 		840 0046 10			
		840 0622 10			
70C17, 70C17 /P 70C17 K, 70C17 DK, 70C17 KK F1CE3481C; (125kW)	07.07-08.11	LUK	 ZF;  6S-400 OD		628 3191 00
			 ZF;  6S-400 OD		415 0221 10
			 ZF;  6S-400A OD		411 0186 11
			 ZF;  6S-400 OD		411 0186 11
			 ZF;  6S-400A OD		411 0186 11
			A/C		531 0812 10
					534 0280 10
			 # F-550532.XX F-556500.XX		535 0103 10
			 # F-559894.XX		535 0176 10
			 right ↑ up		821 0525 10
 right ↓ down		821 0527 10			
 left ↑ up		821 0524 10			
 left ↓ down		821 0526 10			
 90 mm		713 6911 30			
		713 6910 90			
 Front; 		818 0483 10			
 Front; 		818 0484 10			
 ↓ down  44,95 mm		825 0242 10			
 ↑ up  43,95 mm		825 0243 10			
ZF; 		840 0046 10			
		840 0622 10			
70C17V, 70C17 V/P F1CE3481C; (125kW)	07.07-08.11	LUK	 6S-400 OD		628 3191 00
			 6S-400 OD 6S-400A OD		415 0221 10
			 6S-400 OD 6S-400A OD		411 0186 11
			A/C		531 0812 10
					534 0280 10
			 # F-550532.XX F-556500.XX		535 0103 10
			 # F-559894.XX		535 0176 10
			 right ↑ up		821 0525 10
			 right ↓ down		821 0527 10
			 left ↑ up		821 0524 10
 left ↓ down		821 0526 10			













































































			SCHAEFFLER
--	--	--	-------------------



















IVECO

DAILY IV

70C17V, 70C17 V/P F1CE3481C; (125kW)	07.07-08.11	FAG		 Set	713 6911 30	
				90 mm	 Set	713 6910 90
				Front;		818 0483 10
				Front;		818 0484 10
				↓down		825 0242 10
				44,95 mm		825 0243 10
				↑up		840 0046 10
				43,95 mm		840 0622 10
	ZF;		840 0046 10			
	↔		840 0622 10			

DAILY V

26L11, 26L11D, 35C11D, 35S11, 40C11 F1AE3481A; (78kW)	09.11-02.14	LUK			628 3182 00	
				415 0738 10		
				411 0186 10		
				530 0232 10		
				531 0505 10		
				532 0441 10		
				532 0298 10		
				533 0061 20		
				535 0022 10		
				FB 4EPK903		
			FB 7PK1325			
			538 0130 10			
		FAG		 ;  BM 35C11, 40C11	 Set	713 6911 20
				73 mm	 Set	713 6911 30
			 ;  BM 26L11, 35S11	90 mm	 Set	713 6911 10
			 ;  BM 26L11, 35S11	90 mm	 Set	713 6911 30
			 ;  BM 35C11, 40C11	90 mm	 Set	840 0046 10
				↔		840 0622 10
				↔		628 3182 00
				415 0738 10		
	411 0186 10					
	530 0232 10					
FAG		 ;  BM 35 C 11, 40 C 11	 Set	713 6911 20		
		73 mm	 Set	713 6911 30		
	 ;  BM 29 L 11, 35 S 11	90 mm	 Set	713 6911 10		
	 ;  BM 29 L 11, 35 S 11	90 mm	 Set	713 6911 30		
	 ;  BM 35 C 11, 40 C 11	90 mm	 Set	840 0046 10		
		↔		840 0622 10		
		↔		628 3182 00		
		415 0738 10				
		411 0186 10				
		530 0232 10				
FAG		 ;  BM 40C11V	 Set	535 0022 10		
	 ;  BM 40C11V	90 mm	 Set	533 0061 20		
		A/C		FB 4EPK903		
		A/C		FB 7PK1325		
		538 0130 10				
		713 6911 20				
		713 6911 30				
		713 6911 10				
		713 6911 30				
		840 0046 10				



















































































29L13, 29L13D, 35C13D, 40C13 F1AE3481B; (93kW)	09.11-02.14	LUK			628 3182 00	
				415 0738 10		
				411 0186 10		
				530 0232 10		
				530 0232 30		
		FAG		 ;  BM 40C11V	 Set	535 0022 10
			 ;  BM 40C11V	90 mm	 Set	533 0061 20
				A/C		FB 4EPK903
				A/C		FB 7PK1325
				538 0130 10		



			SCHAEFFLER
--	--	--	-------------------

IVECO

DAILY V

























































































29L13, 29L13D, 35C13D, 40C13 F1AE3481B; (93kW)	09.11-02.14		 # F-230846.XX  BM 29*  # F-550532.XX F-556500.XX A/C 	 535 0022 10  535 0103 10  FB 4EPK903  FB 7PK1325  538 0130 10								
			FAG	 ;  BM 35C13, 40C13  73 mm  ;  BM 29L13  90 mm  ;  BM 29L13  90 mm  ;  BM 35C13, 40C13  90 mm  ↔  ↔	 Set 713 6911 20  Set 713 6911 30  Set 713 6911 10  Set 713 6911 30  840 0046 10  840 0622 10							
				LUK	 628 3182 00  415 0738 10  411 0186 10  530 0232 10  530 0232 30  531 0505 10  532 0441 10  532 0298 10  533 0061 20  535 0022 10							
						 535 0103 10  FB 4EPK903  FB 7PK1325  538 0130 10						
						FAG	 Set 713 6911 20  Set 713 6911 30  Set 713 6911 10  Set 713 6911 30  840 0046 10  840 0622 10					
							29L13 V, 35C13 V, 35S13 V, 40C13 V, 40S13 V F1AE3481B; (93kW)	09.11-02.14	LUK	 627 3051 00  531 0505 10  532 0441 10  532 0298 10  533 0061 20  535 0022 10  535 0103 10  FB 4EPK903  FB 7PK1325		
										 Set 713 6911 20  Set 713 6911 30  Set 713 6911 10  Set 713 6911 30  840 0046 10  840 0622 10		
										FAG	 ;  BM 35C15, 40C15, 50C15  73 mm  ;  BM 29L15  90 mm  ;  BM 29L15  90 mm  ;  BM 35C15, 40C15, 50C15  90 mm  ↔  ↔	
					29L15 V, 35S15, 35C15L V, 40C15L V, 50C15L V F1AE3481C; (107kW)						09.11-02.14	LUK
												



			<p>SCHAEFFLER</p>
--	--	--	--------------------------

IVECO





































































































































DAILY V

<p>29L15 V, 35S15 V, 35C15L V, 40C15L V, 50C15L V F1AE3481C; (107kW)</p>	<p>09.11-02.14</p>	<p></p>	<p>  BM 29* 35* # F-230846.XX   BM 29* # F-550532.XX F-556500.XX A/C;  BM 40C15 50C15</p>	<p> 532 0441 10  532 0298 10  533 0061 20  535 0022 10  535 0103 10  FB 4EPK903  FB 6PK1218  FB 7PK1325  538 0130 10</p>
<p>35C11K, 35S11DKP F1AE3481A; (78kW)</p>	<p>09.11-02.14</p>	<p></p> <p></p>	<p>  BM 35C15, 40C15, 50C15  73 mm   BM 29L15  90 mm   BM 29L15  90 mm   BM 35C15, 40C15, 50C15  90 mm  ↔  ↔</p>	<p>  713 6911 20   713 6911 30   713 6911 10   713 6911 30  ↔ 840 0046 10  ↔ 840 0622 10  628 3182 00  415 0738 10  411 0186 10  530 0232 10   530 0232 30  531 0505 10  532 0441 10  532 0298 10  533 0061 20  535 0022 10  535 0103 10  FB 4EPK1102  FB 4EPK903  FB 7PK1325  538 0130 10</p>
<p>35C13K, 35C13DKP F1AE3481B; (93kW)</p>	<p>09.11-02.14</p>	<p></p> <p></p>	<p>  BM 35C11  73 mm   BM 35S11  90 mm   BM 35S11  90 mm   BM 35C11  90 mm  ↔  ↔</p>	<p> 628 3182 00  415 0738 10  411 0186 10   530 0232 10   530 0232 30  531 0505 10  532 0441 10  532 0298 10  533 0061 20  535 0022 10  535 0103 10  FB 4EPK1102  FB 4EPK903 FB 7PK1325 538 0130 10 713 6911 20 713 6911 30 ↔ 840 0046 10 ↔ 840 0622 10</p>



			SCHAEFFLER
--	---	--	-------------------

IVECO

DAILY V					
35C15, 35C15D, 35S15, 40C15, 45C15, 50C15, 60C15, 65C15, ... F1CE3481B; F1CE3481J; (107kW)	09.11-02.14		 A/C	 628 3332 00	
				 531 0812 10	
			 BM 35*	 534 0280 10	
			 # F-230846.XX	 535 0022 10	
			 # F-550532.XX F-556500.XX	 535 0103 10	
			 BM 60C15	 535 0176 10	
			 # F-559894.XX	 FB 6PK1218	
				 538 0472 10	
			FAG  ;  BM 35C15, 40C15, 50C15	 Set 713 6911 20	
			 73 mm		
			 ;  BM 35S15 60C15, 70C15	 Set 713 6911 30	
			 90 mm		
			 ;  BM 60C15, 70C15	 Set 713 6910 90	
			 ;  BM 35S15	 Set 713 6911 10	
			 90 mm		
 ;  BM 35C15, 40C15, 50C15	 Set 713 6911 30				
 90 mm					
	 840 0046 10				
	 840 0622 10				
	 628 3332 00				
35C15K, 35S15DKP, 50C15K, 60C15K, 65C15DK, 70C15K F1CE3481B; (107kW)	09.11-02.14		 A/C	 628 3332 00	
				 531 0812 10	
			 BM 35*	 534 0280 10	
			 # F-230846.XX	 535 0022 10	
			 # F-550532.XX F-556500.XX	 535 0103 10	
			 BM 60C15	 535 0176 10	
			 # F-559894.XX	 538 0472 10	
				 713 6911 20	
			FAG  ;  BM 35C15, 50C15	 Set 713 6911 20	
			 73 mm		
			 ;  BM 35S15 65C15, 70C15	 Set 713 6911 30	
			 90 mm		
			 ;  BM 65C15, 70C15	 Set 713 6910 90	
			 ;  BM 35S15	 Set 713 6911 10	
			 90 mm		
 ;  BM 35C15, 50C15	 Set 713 6911 30				
 90 mm					
	 840 0046 10				
	 840 0622 10				
	 628 3332 00				
35C15 V, 40C15 V, 45C15 V, 50C15 V, 60C15 V, 65C15 V F1CE3481B; F1CE3481J; (107kW)	09.11-02.14		 A/C	 628 3332 00	
				 531 0812 10	
			 BM 35*	 534 0280 10	
			 # F-230846.XX	 535 0022 10	
			 # F-550532.XX F-556500.XX	 535 0103 10	
			 BM 60C15	 535 0176 10	
			 # F-559894.XX	 538 0472 10	
				 713 6911 20	
			FAG  ;  73 mm	 Set 713 6911 20	
					
			 90 mm	 Set 713 6911 30	
					
				 840 0046 10	
				 840 0622 10	
				 628 3332 00	
35C17, 35C17D, 35S17, 40C17, 45C17, 50C17, 60C17, 70C17 F1CE3481C; F1CE3481K; (125kW)	09.11-02.14		 A/C	 628 3191 00	
				 531 0812 10	
			 # F-550532.XX F-556500.XX	 534 0280 10	
			 BM 60C17	 535 0103 10	
			 # F-559894.XX	 535 0176 10	
				 538 0472 10	
				 713 6911 20	
			FAG  ;  BM 35C17, 40C17 45C17, 50C17	 Set 713 6911 20	
			 73 mm		
			 ; BM 35S17 60C17, 70C17	 Set 713 6911 30	
			90 mm		
			; BM 60C17, 70C17	Set 713 6910 90	



			SCHAEFFLER
--	--	--	-------------------

IVECO

DAILY V









































































































35C17, 35C17D, 35S17, 40C17, 45C17, 50C17, 60C17, 70C17 F1CE3481C; F1CE3481K; (125kW)	09.11-02.14	FAG	; BM 35S17 90 mm		713 6911 10		
			; BM 35C17, 40C17 45C17, 50C17 90 mm		713 6911 30		
			↔ ↔		840 0046 10		
			↔		840 0622 10		
					628 3191 00		
					A/C		531 0812 10
							534 0280 10
					# F-550532.XX F-556500.XX		535 0103 10
					# F-559894.XX		535 0176 10
							538 0472 10
35C17K, 35S17DKP, 50C17K, 65C17DK 70C17K F1CE3481C; F1CE3481K; (125kW)	09.11-02.14	FAG	; BM 35C17, 50C17 73 mm		713 6911 20		
			; BM 35S17 65C17, 70C17 90 mm		713 6911 30		
			; BM 65C17, 70C17		713 6910 90		
			; BM 35S17 90 mm		713 6911 10		
			; BM 35C17, 50C17 90 mm		713 6911 30		
			↔ ↔		840 0046 10		
			↔		840 0622 10		
					628 3191 00		
					A/C		531 0812 10
							534 0280 10
35C17 V, 35S17 V, 40C17 V, 45C17 V, 50C17 V, 60C17 V F1CE3481C; F1CE3481K; (125kW)	09.11-02.14	FAG	; BM 45C17 90 mm		535 0176 10		
					# F-550532.XX F-556500.XX		535 0103 10
					# F-559894.XX		535 0176 10
							538 0472 10
			; ABS ; BM 35C17, 40C17, 50C17 73 mm		713 6911 20		
			; BM 35 S 17 90 mm		713 6911 30		
			; BM 35 S 17 90 mm		713 6911 10		
			; BM 35C17, 40C17, 50C17 90 mm		713 6911 30		
			↔ ↔		840 0046 10		
			↔		840 0622 10		
35C21, 35S21, 40C21, 45C21, 50C21, 60C21, 70C21 F1CE3481D; (150kW)	09.11-02.14	LUK			631 3174 00		
					415 0808 10		
					A/C		531 0812 10
							534 0280 10
					# F-550532.XX F-556500.XX		535 0103 10
					# F-559894.XX		535 0176 10
							538 0472 10
			; BM 35C21, 40C21 45C21, 50C21 73 mm		713 6911 20		
			; BM 35S21 60C21, 70C21 90 mm		713 6911 30		
			; BM 60C21, 70C21		713 6910 90		
; BM 35S21 90 mm		713 6911 10					
; BM 35C21, 40C21 45C21, 50C21 90 mm		713 6911 30					
↔ ↔		840 0046 10					
↔		840 0622 10					
35C21 V, 35S21 V, 40C21 V, 45C21 V, 50C21 V F1CE3481D; (150kW)	09.11-02.14	LUK			631 3174 00		
					415 0808 10		
					A/C		531 0812 10
							534 0280 10
					# F-550532.XX F-556500.XX		535 0103 10
					# F-559894.XX		535 0176 10
							538 0472 10













			SCHAEFFLER
--	---	--	-------------------

IVECO

DAILY V

35C21 V, 35S21 V, 40C21 V, 45C21 V, 50C21 V F1CE3481D; (150kW)	09.11-02.14	FAG	 BM 35C21, 40C21, 50C21  73 mm		713 6911 20	
			 BM 35S21  90 mm		713 6911 30	
			 BM 35S21  90 mm		713 6911 10	
			 BM 35C21, 40C21, 50C21  90 mm		713 6911 30	
			 ↔  ↔		840 0046 10	
35S, 35C Electric F1CE (60kW)	09.11-02.14	FAG	 BM 35C  73 mm		713 6911 20	
			 BM 35S  90 mm		713 6911 30	
			 BM 35S  90 mm		713 6911 10	
			 BM 35C  90 mm		713 6911 30	
			 ↔  ↔		840 0046 10	
35 S 14 F1CE3481L; (110kW)	04.12-02.14		 # F-550532.XX F-556500.XX		535 0103 10	
			FAG	  90 mm		713 6911 30
				  90 mm		713 6911 10
				 ↔		840 0046 10
				 ↔		840 0622 10
50 C Electric F1CE (80kW)	09.11-02.14	FAG	  73 mm		713 6911 20	
			  90 mm		713 6911 30	
			 ↔		840 0046 10	
			 ↔		840 0622 10	
			Natural Power 35S14, 35C14, 40C14, 50C14, 65C14, 70C14 F1CE0441A; (100kW)	09.11-02.14	LUK	 F1CE0441A;  2840.6 OD incl.  
 F1CE0441A;  2840.6 OD		628 3332 00				
 F1CE0441A;  2840.6 OD		415 0221 10				
 F1CE0441A;  2840.6 OD		411 0186 11				
	 # F-550532.XX F-556500.XX				535 0103 10	
	 # F-559894.XX				535 0176 10	
FAG	 BM 35C14, 40C14, 50C14  73 mm				713 6911 20	
	 BM 35S14 65C14, 70C14  90 mm				713 6911 30	
	 BM 65C14, 70C14				713 6910 90	
	 BM 35S14  90 mm				713 6911 10	
	 BM 35C14, 35C14, 50C14  90 mm		713 6911 30			
	 # F-550532.XX F-556500.XX		535 0103 10			
FAG	 # F-559894.XX		535 0176 10			
	 BM 35C14, 40C14, 50C14  73 mm		713 6911 20			
	 BM 35S14 65C14, 70C14  90 mm		713 6911 30			
	 BM 65C14, 70C14		713 6910 90			
	 BM 35S14  90 mm		713 6911 10			
	 BM 35C14, 35C14, 50C14  90 mm		713 6911 30			
	 # F-550532.XX F-556500.XX		535 0103 10			

DAILY VI











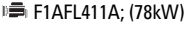















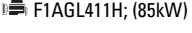

















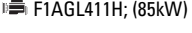

























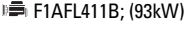







33S11, 35S11, 35C11 F1AFL411A; (78kW)	03.14-04.16	LUK	 2835.6 DOD		627 3051 00
			 2835.6 DOD		627 3051 00
			 2835.6 DOD		415 0738 10
			 2835.6 DOD		415 0738 10
			 2835.6 DOD		411 0186 10



			<p>SCHAEFFLER</p>
--	--	--	--------------------------

IVECO

























































































































DAILY VI

<p>33S11, 35S11, 35C11  F1AFL411A; (78kW)</p>	<p>03.14-04.16</p>	<p> </p>	<p> 411 0186 10  530 0232 10  530 0232 30  531 0505 10  532 0441 10  532 0298 10  533 0061 20  535 0235 10  FB 4EPK903  FB 7PK1325  538 0130 10</p>	<p> 713 6911 20  713 6911 10  713 6911 30</p>
<p>33S12, 35S12  F1AGL411H; (85kW)</p>	<p>04.16-</p>	<p> </p>	<p> 2835.6  2835.6  2835.6  411 0186 10  530 0232 10  530 0232 30  531 0505 10  532 0441 10  532 0298 10  533 0061 20  535 0235 10  FB 4EPK903  FB 7PK1325  538 0130 10</p>	<p> 713 6911 10</p>
<p>33S12, 35S12, 35C12  F1AGL411H; (85kW)</p>	<p>04.16-</p>	<p> </p>	<p> F1AGL411H;  2835.6  F1AGL411H;  2835.6  F1AGL411H;  2835.6  F1AGL411H;  2835.6  411 0186 10  411 0186 11  530 0232 10  530 0232 30  531 0505 10  532 0441 10  532 0298 10  533 0061 20  535 0235 10  FB 4EPK903  FB 7PK1325  538 0130 10</p>	<p> 713 6911 20  713 6911 10  713 6911 10  713 6911 30</p>
<p>33S13, 35S13, 35C13  F1AFL411B; (93kW)</p>	<p>03.14-04.16</p>	<p> </p>	<p> 2835.6 DOD  2835.6 DOD  2835.6 DOD  2835.6 DOD  530 0232 10  530 0232 30  531 0505 10  532 0441 10  532 0298 10</p>	<p> 627 3051 00  627 3051 00  415 0738 10  415 0738 10  411 0186 10  411 0186 10</p>



			SCHAEFFLER
--	---	--	-------------------

IVECO











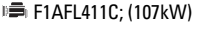













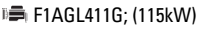















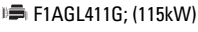

















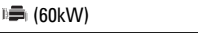



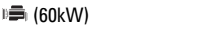













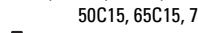









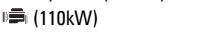

DAILY VI						
33S13, 35S13, 35C13 F1AFL411B; (93kW)	03.14-04.16				533 0061 20	
			 BM 35*  # F-560671.XX		535 0235 10	
			A/C		FB 4EPK903	
					FB 7PK1325	
					538 0130 10	
		FAG	 ; ABS ;  BM 35C13  73 mm	 Set	713 6911 20	
			 ;  BM 33S13, 35S13  90 mm	 Set	713 6911 10	
			 ;  BM 35C13  90 mm	 Set	713 6911 30	
33S14, 35S14 F1AGL411J; (100kW)	04.16-		 F1AGL411J;  2835.6 DOD		627 3051 00	
			 F1AGL411J;  2835.6 DOD		415 0738 10	
			 F1AGL411J;  2835.6 DOD		411 0186 10	
					530 0232 10	
					530 0232 30	
					531 0505 10	
					532 0441 10	
					532 0298 10	
					533 0061 20	
			 BM 35*  # F-550532.XX F-556500.XX  # F-560671.XX		535 0103 10	
A/C		FB 4EPK903				
		FB 7PK1325				
		538 0130 10				
33S14, 35S14, 35C14 F1AGL411J; (100kW)	04.16-		 F1AGL411J;  2835.6 DOD		627 3051 00	
			 F1AGL411J;  2835.6 DOD		415 0738 10	
			 F1AGL411J;  2835.6 DOD		415 0738 10	
					411 0186 10	
					530 0232 10	
					530 0232 30	
					531 0505 10	
					532 0441 10	
					532 0298 10	
					533 0061 20	
 BM 35*  # F-550532.XX F-556500.XX  BM 35*  # F-560671.XX		535 0103 10				
A/C		FB 4EPK903				
		FB 7PK1325				
		538 0130 10				
33S15, 35S15, 35C15 F1AFL411C; (107kW)	03.14-04.16				627 3051 00	
					415 0738 10	
					411 0186 10	
					530 0232 10	
					530 0232 30	
					531 0505 10	
					532 0441 10	
					532 0298 10	
					533 0061 20	
			 BM 33*  # F-550532.XX F-556500.XX  BM 35*  # F-560671.XX		535 0103 10	
A/C		FB 4EPK903				
		FB 7PK1325				
		538 0130 10				



			<p>SCHAEFFLER</p>
--	--	--	--------------------------

IVECO







































































































DAILY VI

<p>33S15, 35S15, 35C15  F1AFL411C; (107kW)</p>	<p>03.14-04.16</p>	<p>FAG</p>	<p> ;  ;  BM 35C15  73 mm</p> <p> ;  BM 33S15, 35S15  90 mm</p> <p> ;  BM 35C15  90 mm</p>	<p> Set 713 6911 20</p> <p> Set 713 6911 10</p> <p> Set 713 6911 30</p>
<p>33S16, 35S16  F1AGL411G; (115kW)</p>	<p>04.16-</p>	<p>LUK</p>	<p> 2835.6  2835.6  2835.6</p>	<p> 627 3051 00</p> <p> 415 0738 10</p> <p> 411 0186 10</p> <p> 530 0232 10</p> <p> 530 0232 30</p> <p> 531 0505 10</p> <p> 532 0441 10</p> <p> 533 0061 20</p> <p> 535 0103 10</p> <p> 535 0235 10</p> <p> A/C FB 4EPK903</p> <p> 538 0130 10</p>
<p>33S16, 35S16, 35C16  F1AGL411G; (115kW)</p>	<p>04.16-</p>	<p>LUK</p>	<p> F1AGL411G;  2835.6  F1AGL411G;  2835.6  F1AGL411G;  2835.6</p>	<p> 627 3051 00</p> <p> 415 0738 10</p> <p> 411 0186 10</p> <p> 530 0232 10</p> <p> 530 0232 30</p> <p> 531 0505 10</p> <p> 532 0441 10</p> <p> 533 0061 20</p> <p> 535 0103 10</p> <p> 535 0235 10</p> <p> A/C FB 4EPK903</p> <p> 538 0130 10</p>
<p>35S/E  (60kW)</p>	<p>09.16-</p>	<p>FAG</p>	<p>  90 mm</p>	<p> Set 713 6911 10</p>
<p>35S/E, 35C/E  (60kW)</p>	<p>09.16-</p>	<p>FAG</p>	<p> ;  ;  BM 35C  73 mm</p> <p> ;  BM 35S  90 mm</p> <p> ;  BM 35C  90 mm</p>	<p> Set 713 6911 20</p> <p> Set 713 6911 10</p> <p> Set 713 6911 30</p>
<p>35S14, 35S15, 35C15, 40S14, 40C15, 50C15, 65C15, 70C15  F1CE3481J; F1CFL411E; F1CFL411J; (107kW)</p>	<p>03.14-04.16</p>	<p>LUK</p>	<p>incl.  ; incl. </p>	<p> 600 0274 00</p> <p> 628 3332 00</p> <p> 415 0221 10</p> <p> 411 0186 11</p> <p> 535 0103 10</p> <p> 535 0176 10</p> <p> 535 0235 10</p>
<p>35S15, 35C15, 40C15, 50C15  (110kW)</p>	<p>04.16-</p>	<p>LUK</p>	<p> FICGL411A;  2840.6 incl.  ; incl. </p> <p> FICGL411A;  2840.6</p> <p> FICGL411A;  2840.6</p> <p> FICGL411A; 2840.6</p>	<p> 600 0274 00</p> <p> 628 3332 00</p> <p> 415 0221 10</p> <p> 411 0186 11</p>



			SCHAEFFLER
--	--	--	-------------------































































































































IVECO

DAILY VI					
35S15, 35C15, 40C15, 50C15 (110kW)	04.16-		# F-550532.XX F-556500.XX  BM 35C15 # F-560671.XX		535 0103 10
			 535 0235 10		
			FAG  ;  BM 35C15, 40C15, 50C15  73 mm		713 6911 20
			 90 mm  BM 35S15  90 mm  BM 35C15, 40C15, 50C15		713 6911 10
			 713 6911 30		
35S15, 35C15, 40C15, 50C15, 65C15, 70C15 FICE3481J; FICFL411E; FICFL411J; (107kW)	03.14-04.16		incl. Ø; incl. 		600 0274 00
				628 3332 00	
				415 0221 10	
				411 0186 11	
			# F-550532.XX F-556500.XX # F-559894.XX  BM 35* # F-560671.XX		535 0103 10
				535 0176 10	
				535 0235 10	
			FAG  ;  BM 35C15, 40C15, 50C15  73 mm		713 6911 20
			 90 mm  BM 65C15, 70C15		713 6911 30
			 90 mm  BM 65C15, 70C15		713 6910 90
	04.16-		 FICGL411A;  2840.6 incl. Ø; incl. 		600 0274 00
			 FICGL411A;  2840.6		628 3332 00
			 FICGL411A;  2840.6		415 0221 10
			 FICGL411A;  2840.6		411 0186 11
		FAG	# F-550532.XX F-556500.XX  BM 35C15 # F-560671.XX		535 0103 10
				535 0235 10	
			 ;  BM 35C15, 40C15, 50C15  73 mm		713 6911 20
			 90 mm  BM 65C15, 70C15		713 6911 30
35S15, 35C15, 40C15, 50C15, 65C15, 70C15, 72C15 (110kW)	04.16-		 FICGL411A;  2840.6 incl. Ø; incl. 		600 0274 00
			 FICGL411A;  2840.6		628 3332 00
			 FICGL411A;  2840.6		415 0221 10
			 FICGL411A;  2840.6		411 0186 11
			# F-550532.XX F-556500.XX  BM 35C15 # F-560671.XX		535 0103 10
				535 0235 10	
			FAG  ;  BM 35C15, 40C15, 50C15  73 mm		713 6911 20
			 90 mm  BM 65C15, 70C15, 72C15		713 6911 30
			 90 mm  BM 65C15, 70C15, 72C15		713 6910 90
			 90 mm  BM 35S15		713 6911 10
35S17, 35C17, 40C17, 45S17, 45C17, 50C17, 55C17, 65C17, ... FICFL411F; FICFL411H; (125kW)	03.14-04.16			415 0221 10	
				411 0186 11	
			# F-550532.XX F-556500.XX  BM 55C17 # F-559894.XX		535 0103 10
				535 0176 10	
			FAG  ;  BM 35C17, 40C17, 50C17  73 mm		713 6911 20



			SCHAEFFLER
--	---	--	-------------------

IVECO**DAILY VI**

35S17, 35C17, 40C17, 45S17, 45C17, 50C17, 55C17, 65C17, ... F1CFL411F; F1CFL411H; (125kW)	03.14-04.16	FAG	 ;  BM 65C17, 70C17		713 6911 30			
			 90 mm					
			 ;  BM 65C17, 70C17		713 6910 90			
			 ;  BM 35S17		713 6911 10			
35S17, 35C17, 40C17, 50C17, 55C17, 65C17, 70C17 F1CFL411F; F1CFL411H; (125kW)	03.14-04.16	LUK	 2840.6.OD		628 3191 00			
			 BM 35S17 70C17					
			 2840.6.OD		415 0221 10			
			 # F-550532.XX F-556500.XX		535 0103 10			
						 BM 55C17		535 0176 10
						 # F-559894.XX		
		FAG	 ;  ABS ;  BM 35C17, 40C17, 50C17		713 6911 20			
				 73 mm				
				 ;  BM 65C17, 70C17		713 6911 30		
				 90 mm				
 ;  BM 65C17, 70C17				713 6910 90				
 ;  BM 35S17				713 6911 10				
 90 mm								
 ;  BM 35C17, 40C17, 50C17		713 6911 30						
	 90 mm							
35S17, 55S17 4x4 F1CFL411F; (125kW)	08.15-04.16	LUK			415 0221 10			
					411 0186 11			
			 # F-550532.XX F-556500.XX		535 0103 10			
						 # F-559894.XX		535 0176 10
		FAG			713 6911 30			
				 90 mm				
 90 mm			713 6911 30					
35S18, 35C18, 40C18, 50C18 F1CFL411W; (132kW)	04.16-		 # F-550532.XX F-556500.XX		535 0103 10			
						FAG	 ;  ABS ;  BM 35C18, 40C18, 50C18	
		 73 mm						
		 ;  BM 35S18		713 6911 10				
		 90 mm						
 ;  BM 35C18, 40C18, 50C18		713 6911 30						
 90 mm								
35S18, 35C18, 40C18, 50C18, 65C18, 70C18 F1CFL411W; F1CGL411B; (132kW)	04.16-		 # F-550532.XX F-556500.XX		535 0103 10			
						FAG	 ;  ABS ;  BM 35C18, 40C18, 50C18	
		 73 mm						
		 ;  BM 65C18, 70C18		713 6911 30				
		 90 mm						
		 ;  BM 65C18, 70C18		713 6910 90				
		 ;  BM 35S18		713 6911 10				
		 90 mm						
		 ;  BM 35C18, 40C18, 50C18		713 6911 30				
		 90 mm						
35S18, 35C18, 40C18, 50C18, 65C18, 70C18, 72C18 F1CFL411W; F1CGL411B; (132kW)	04.16-	LUK	 F1CGL411B;  2840.6		415 0221 10			
			 F1CGL411B;  2840.6		411 0186 11			
			 # F-550532.XX F-556500.XX		535 0103 10			
						FAG	 ;  ABS ;  BM 35C18, 40C18, 50C18	
		 73 mm						
		 ;  BM 65C18, 70C18, 72C18		713 6911 30				
		 90 mm						
		 ;  BM 65C18, 70C18, 72C18		713 6910 90				
 ;  BM 35S18		713 6911 10						
 90 mm								
 ;  BM 35C18, 40C18, 50C18		713 6911 30						
 90 mm								
35S18, 55S18 4x4 F1CFL411W; F1CGL411B; (132kW)	09.16-		 # F-550532.XX F-556500.XX		535 0103 10			
						FAG		
 90 mm								





IVECO











































































































































DAILY VI

35S18, 55S18 4x4 F1CFL411W; F1CGL411B; (132kW)	09.16-	FAG	90 mm		713 6911 30
35S21, 35C21, 40C21, 50C21, 65C21, 70C21 F1CFL411G; F1CGL411C; (150kW)	03.14-	LUK			631 3174 00
					415 0808 10
			## F-550532.XX F-556500.XX		535 0103 10
			## F-559894.XX		535 0176 10
		FAG	; ; BM 35C21, 40C21, 50C21		713 6911 20
			; BM 65C21, 70C21		713 6911 30
			; BM 65C21, 70C21		713 6910 90
	; BM 35S21		713 6911 10		
	; BM 35C21, 40C21, 50C21		713 6911 30		
40C15, 50C15, 60C15 F1CE3481J; F1CFL411E; (107kW)	06.14-10.16	LUK	incl. ; incl.		600 0274 00
					628 3332 00
					415 0221 10
					411 0186 11
			## F-550532.XX F-556500.XX		535 0103 10
		FAG	; ; BM 40 C 15, 50 C 15		713 6911 20
			; BM 60 C 15		713 6911 30
			; BM 60 C 15		713 6910 90
			; BM 40 C 15, 50 C 15		713 6911 30
			; BM 40 C 15, 50 C 15		713 6911 30
40C15, 50C15, 60C15 (110kW)	11.16-	LUK	2840.6		600 0274 00
			incl. ; incl.		628 3332 00
			2840.6		415 0221 10
			2840.6		411 0186 11
			## F-550532.XX F-556500.XX		535 0103 10
		FAG	; ; BM 40 C 15, 50 C 15		713 6911 20
			; BM 60 C 15		713 6911 30
			; BM 60 C 15		713 6910 90
			; BM 40 C 15, 50 C 15		713 6911 30
			; BM 40 C 15, 50 C 15		713 6911 30
40C15, 50C15, 65C15 (107kW)	03.14-04.16	LUK	incl. ; incl.		600 0274 00
					628 3332 00
					415 0221 10
					411 0186 11
			## F-550532.XX F-556500.XX		535 0103 10
		FAG	; ; BM 40C15, 50C15		713 6911 20
			; BM 65C15		713 6911 30
			; BM 65C15		713 6910 90
			; BM 40C15, 50C15		713 6911 30
			; BM 40C15, 50C15		713 6911 30
40C17, 50C17, 60C17 F1CFL411F; (125kW)	06.14-10.16	LUK	2840.6 OD		628 3191 00
			2840.6 OD		415 0221 10
			2840.6 OD		411 0186 11
			## F-550532.XX F-556500.XX		535 0103 10
		FAG	; ; BM 40 C 17, 50 C 17		713 6911 20
			; BM 60 C 17		713 6911 30
			; BM 60 C 17		713 6910 90
			; BM 60 C 17		713 6910 90
			; BM 60 C 17		713 6910 90
			; BM 60 C 17		713 6910 90



			SCHAEFFLER
--	---	--	-------------------



































IVECO**DAILY VI**

40C17, 50C17, 60C17  F1CFL411F; (125kW)	06.14-10.16	FAG	 BM 40 C 17, 50 C 17  90 mm		713 6911 30	
40C17, 50C17, 65C17  (125kW)	03.14-04.16	LUK	 F1CE3481C;  2840.6 OD		628 3191 00	
			 F1CE3481C;  2840.6 OD		415 0221 10	
			 F1CE3481C;  2840.6 OD		411 0186 11	
		IINA	 # F-550532.XX F-556500.XX		535 0103 10	
			FAG	 ABS ;  BM 40C17, 50C17  73 mm		713 6911 20
				 BM 65C17  90 mm		713 6911 30
 BM 65C17  90 mm		713 6910 90				
40C18, 50C18, 60C18  (132kW)	11.16-	IINA	 # F-550532.XX F-556500.XX		535 0103 10	
			FAG	 ABS ;  BM 40C18, 50C18  73 mm		713 6911 20
				 BM 60C18  90 mm		713 6911 30
				 BM 60C18  90 mm		713 6910 90
				 BM 40C18, 50C18  90 mm		713 6911 30
45C/E, 50C/E  (80kW)	09.16-	FAG	 ABS ;  BM 45C, 50C  73 mm		713 6911 20	
			 ABS  73 mm		713 6911 20	
			  90 mm		713 6911 30	
			 BM 45C, 50C  90 mm		713 6911 30	
			  90 mm		713 6911 30	
50C/E  (80kW)	10.15-	FAG	 ABS  73 mm		713 6911 20	
			  90 mm		713 6911 30	
50C/E  (80kW)	10.15-10.16	FAG	  73 mm		713 6911 20	
			  90 mm		713 6911 30	
			  90 mm		713 6911 30	
50C14G Natural Power 50C14 Natural Power 50C15  F1CE3481J; F1CFA401A; F1CFL411E; (100-107kW)	06.14-	LUK	incl.   		600 0274 00	
			  		628 3332 00	
			  		415 0221 10	
			  		411 0186 11	
		IINA	 # F-550532.XX F-556500.XX		535 0103 10	
			FAG	  73 mm		713 6911 20
				  90 mm		713 6911 30
50C17  F1CFL411F; (125kW)	06.14-10.16	LUK	  		628 3191 00	
			  		415 0221 10	
			  		411 0186 11	
		IINA	 # F-550532.XX F-556500.XX		535 0103 10	
			FAG	  73 mm		713 6911 20
				  90 mm		713 6911 30
50C17, 65C17  F1CFL411F; (125kW)	06.14-10.16	LUK	 2840.6 OD		628 3191 00	
			 2840.6 OD		415 0221 10	
			 2840.6 OD		411 0186 11	
		IINA	 # F-550532.XX F-556500.XX		535 0103 10	
			FAG	 ABS ;  BM 50 C 17  73 mm		713 6911 20
				 BM 65 C 17  90 mm		713 6911 30

















			SCHAEFFLER
--	--	--	-------------------

IVECO

DAILY VI					
50C17, 65C17 F1CFL411F; (125kW)	06.14-10.16	FAG	BM 65 C 17		713 6910 90
			BM 50 C 17 90 mm		713 6911 30
50C18, 65C18 F1CFL411F; (132kW)	11.16-	FAG	F-550532.XX F-556500.XX		535 0103 10
			ABS; BM 50 C 18 73 mm		713 6911 20
			BM 65 C 18 90 mm		713 6911 30
			BM 65 C 18		713 6910 90
			BM 50 C 18 90 mm		713 6911 30
Natural Power 35S14, 35C14, 40C14, 50C14 F1CFL411F; (100kW)	04.16-	FAG	F-550532.XX F-556500.XX		535 0103 10
			ABS; BM 35C14, 40C14, 50C14 73 mm		713 6911 20
			BM 35S14 90 mm		713 6911 10
			BM 35C14, 40C14, 50C14 90 mm		713 6911 30
Natural Power 35S14, 35C14, 40C14, 50C14, 65C14, 70C14 F1CFA401A; F1CFA401B; (100kW)	03.14-	LUK	incl. Ø; incl. 		600 0274 00
				628 3332 00	
				415 0221 10	
				411 0186 11	
		FAG	F-550532.XX F-556500.XX		535 0103 10
			BM 65C14 70C114		535 0176 10
			F-559894.XX		
			ABS; BM 35C14, 40C14, 50C14 73 mm		713 6911 20
			BM 65C14, 70C14 90 mm		713 6911 30
			BM 65C14, 70C14		713 6910 90
FAG	BM 35S14 90 mm		713 6911 10		
	BM 35C14, 40C14, 50C14 90 mm		713 6911 30		
	LUK	incl. Ø; incl. 		600 0274 00	
			628 3332 00		
			415 0221 10		
			411 0186 11		
FAG	F-550532.XX F-556500.XX		535 0103 10		
	BM 65C14 70C14		535 0176 10		
	F-559894.XX				
	ABS; BM 35C14, 40C14, 50C14 73 mm		713 6911 20		
	BM 65C14, 70C14 90 mm		713 6911 30		
	BM 65C14, 70C14		713 6910 90		
FAG	BM 35S14 90 mm		713 6911 10		
	BM 35C14, 40C14, 50C14 90 mm		713 6911 30		

MAN

























TGE Bus (UY_)					
2.0 TDI 2.0 TDI AWD DAVA; (130kW)	02.17-				530 0650 10
					531 0894 10
					532 0161 10
					532 0623 10
			angetr. Agg.: 2.Klimakompressor		532 0565 10
			2. 		538 0807 10
TGE Kasten (UY_, UX_)					
2.0 TDI DAUB; (75kW)	02.17-		angetr. Agg.: 2.Klimakompressor		532 0565 10
			2. 		
			F-551406.XX		535 0124 10
			2. 		535 0222 10
			F-551623.XX		





































			SCHAEFFLER
--	--	--	-------------------

MAN

TGE Kasten (UY_, UX_)



















































2.0 TDI 2.0 TDI AWD DAUA; (103kW)	02.17-		angetr. Agg.: 2.Klimakompressor		532 0161 10
			2. 		532 0623 10
			 # F-551406.XX		532 0565 10
			2.  ; 09.17→		535 0124 10
			 # F-551623.XX		535 0222 10
2.0 TDI 2.0 TDI AWD DAVA; (130kW)	02.17-				530 0650 10
					531 0894 10
					532 0161 10
					532 0623 10
			angetr. Agg.: 2.Klimakompressor		532 0565 10
			2. 		
			 # F-551406.XX		535 0124 10
			2.  ; 09.17→		535 0222 10
			 # F-551623.XX		538 0807 10

TGE Pritsche/Fahrgestell (UZ_)

2.0 TDI DAUB; (75kW)	11.16-		angetr. Agg.: 2.Klimakompressor		532 0565 10
			2. 		535 0124 10
			 # F-551406.XX		535 0222 10
			2.  ; 09.17→		535 0222 10
2.0 TDI DAUA; (103kW)	11.16-				532 0161 10
					532 0623 10
			angetr. Agg.: 2.Klimakompressor		532 0565 10
			2. 		
			 # F-551406.XX		535 0124 10
2.0 TDI DAVA; (130kW)	11.16-				530 0650 10
					531 0894 10
					532 0161 10
					532 0623 10
			angetr. Agg.: 2.Klimakompressor		532 0565 10
			2. 		
			 # F-551406.XX		535 0124 10
			2.  ; 09.17→		535 0222 10
			 # F-551623.XX		538 0807 10

MERCEDES-BENZ

Sprinter (903) 3-t









































































































311 CDI 4x4 OM 611.981; (80kW)	08.02-05.06		 BM 903.661-663 903.671-673; 		600 0056 00
			incl.  ; incl.  ; SAC		
			 BM 903.611/612/613 903.621/622/623; 		600 0056 00
			incl.  ; incl.  ; SAC		
			 BM 903.671-673; 		600 0056 00
			incl.  ; incl.  ; SAC		
			 BM 903.671-673;  →R 636764		624 3148 09
			 BM 903.671-673;  →A 920786		
			SAC		
			 BM 903.671-673;  →R 636764		624 3148 33
			 BM 903.671-673;  →A 920.786		
			SAC		
			 BM 903.611 / .612/ .613 903.621 / .622/ .623;  →R 636764		624 3148 33
			 BM 903.611 / .612/ .613 903.621 / .622/ .623;  →A 920786		
			SAC		
			 BM 903.661 / .662/ .663;  →R 636764		624 3148 33
			 BM 903.661 / .662/ .663;  →A 920786		
			SAC		
 BM 903.671-673;  →R 636.764; 		624 3148 34			
 BM 903.671-673;  →A 920 786; 					
SAC					
 BM 903.611 / .612 / .613 903.621 / .622 / .623;		624 3148 34			
 →R 636764; 					
 BM 903.611 / .612 / .613 903.621 / .622 / .623;					
 →A 920786; 					
SAC					



			SCHAEFFLER
--	---	--	-------------------

MERCEDES-BENZ















Sprinter (903) 3-t

311 CDI 4x4 OM 611.981; (80kW)	08.02-05.06		 BM 903.661 /.662 /.663;  →R 636764;  SEQU		624 3148 34																										
			 BM 901.661 /.662 /.663;  →A 920786;  SEQU SAC																												
			 BM 903.661 /.662 /.663;  R 636765→				624 3182 33																								
			 BM 903.661 /.662 /.663;  A 920787→ SAC																												
			 BM 903.611 /.612 /.613 903.621 /.622 /.623;  R 636765→						624 3182 33																						
			 BM 903.611 /.612 /.613 903.621 /.622 /.623;  A 920787→ SAC																												
			 BM 903.671-673;  R 636765→								624 3182 33																				
			 BM 903.671-673;  A 920787→ SAC																												
			 BM 903.671-673;  R 636765→;  SEQU										624 3182 34																		
			 BM 903.671-673;  A 920787→;  SEQU SAC																												
			 BM 903.611 /.612 /.613 903.621 /.622 /.623;  R 636765→;  SEQU												624 3182 34																
			 BM 903.611 /.612 /.613 903.621 /.622 /.623;  A 920787→;  SEQU SAC																												
			 BM 903.661 /.662 /.663;  R 636765→;  SEQU														624 3182 34														
			 BM 903.661 /.662 /.663;  A 920787→;  SEQU SAC																												
			 BM 903.661 /.662 /.663; + 624 3182 09/33/34																415 0239 10												
			 BM 903.611 /.612 /.613 903.621 /.622 /.623; + 624 3182 09/33/34																												
			 BM 903.671-673; + 624 3182 09/33/34																		415 0239 10										
			 BM 903.611 /.612 /.613 903.621 /.622 /.623; + 624 3182 09/33/34																												
			 BM 903.671-673; + 624 3182 09/33/34																				415 0239 10								
			 BM 903.611 /.612 /.613 903.621 /.622 /.623; + 624 3182 09/33/34																												
			 BM 903.671-673; + 624 3182 09/33/34																						415 0239 10						
			 BM 903.611 /.612 /.613 903.621 /.622 /.623; + 624 3182 09/33/34																												
			 BM 903.671-673; + 624 3182 09/33/34																								415 0239 10				
			 BM 903.611 /.612 /.613 903.621 /.622 /.623; + 624 3182 09/33/34																												
			 BM 903.671-673; + 624 3182 09/33/34																										415 0239 10		
			 BM 903.611 /.612 /.613 903.621 /.622 /.623; + 624 3182 09/33/34																												
			 BM 903.671-673; + 624 3182 09/33/34																												415 0239 10
			 BM 903.611 /.612 /.613 903.621 /.622 /.623; + 624 3182 09/33/34																												
 BM 903.671-673; + 624 3182 09/33/34		415 0239 10																													
 BM 903.611 /.612 /.613 903.621 /.622 /.623; + 624 3182 09/33/34																															
 BM 903.671-673; + 624 3182 09/33/34				415 0239 10																											
 BM 903.611 /.612 /.613 903.621 /.622 /.623; + 624 3182 09/33/34																															
 BM 903.671-673; + 624 3182 09/33/34						415 0239 10																									
 BM 903.611 /.612 /.613 903.621 /.622 /.623; + 624 3182 09/33/34																															
 BM 903.671-673; + 624 3182 09/33/34								415 0239 10																							
 BM 903.611 /.612 /.613 903.621 /.622 /.623; + 624 3182 09/33/34																															
 BM 903.671-673; + 624 3182 09/33/34										415 0239 10																					
 BM 903.611 /.612 /.613 903.621 /.622 /.623; + 624 3182 09/33/34																															
 BM 903.671-673; + 624 3182 09/33/34												415 0239 10																			
 BM 903.611 /.612 /.613 903.621 /.622 /.623; + 624 3182 09/33/34																															
 BM 903.671-673; + 624 3182 09/33/34														415 0239 10																	
 BM 903.611 /.612 /.613 903.621 /.622 /.623; + 624 3182 09/33/34																															
 BM 903.671-673; + 624 3182 09/33/34																415 0239 10															
 BM 903.611 /.612 /.613 903.621 /.622 /.623; + 624 3182 09/33/34																															
 BM 903.671-673; + 624 3182 09/33/34																		415 0239 10													
 BM 903.611 /.612 /.613 903.621 /.622 /.623; + 624 3182 09/33/34																															
 BM 903.671-673; + 624 3182 09/33/34																				415 0239 10											
 BM 903.611 /.612 /.613 903.621 /.622 /.623; + 624 3182 09/33/34																															
 BM 903.671-673; + 624 3182 09/33/34																						415 0239 10									
 BM 903.611 /.612 /.613 903.621 /.622 /.623; + 624 3182 09/33/34																															
 BM 903.671-673; + 624 3182 09/33/34																								415 0239 10							
 BM 903.611 /.612 /.613 903.621 /.622 /.623; + 624 3182 09/33/34																															
 BM 903.671-673; + 624 3182 09/33/34																										415 0239 10					
 BM 903.611 /.612 /.613 903.621 /.622 /.623; + 624 3182 09/33/34																															

313 CDI 4x4
 OM 611.981; (95kW)

08.02-05.06



 **BM** 903.671-673;  SEQU
 incl. ; incl. ; SAC
 **BM** 903.611/612/613 903.621/622/623;  SEQU
 incl. ; incl. ; SAC
 **BM** 903.661-663;  SEQU
 incl. ; incl. ; SAC
 **BM** 903.671-673;  →R 636764
 BM 903.671-673; →A 920786
 SAC

 600 0056 00
 600 0056 00
 600 0056 00
 624 3148 33



			SCHAEFFLER
--	--	--	-------------------

MERCEDES-BENZ

Sprinter (903) 3-t

313 CDI 4x4
OM 611.981; (95kW)

08.02-05.06



BM 903.661 / .662 / .663; →R 636764		624 3148 33
BM 903.661 / .662 / .663; →A 920786		
SAC		
BM 903.611 / .612 / .613 903.621 / .622 / .623; →R 636764		624 3148 33
BM 903.611 / .612 / .613 903.621 / .622 / .623; →A 920786		
SAC		
BM 903.661 / .662 / .663; →R 636764; →SEQU		624 3148 34
BM 901.661 / .662 / .663; →A 920786; →SEQU		
SAC		
BM 903.671-673; →R 636764; →SEQU		624 3148 34
BM 903.671-673; →A 920786; →SEQU		
SAC		
BM 903.611 / .612 / .613 903.621 / .622 / .623; →R 636764; →SEQU		624 3148 34
BM 903.611 / .612 / .613 903.621 / .622 / .623; →A 920786; →SEQU		
SAC		
BM 903.661 / .662 / .663; R 636765→		624 3182 33
BM 903.661 / .662 / .663; A 920787→		
SAC		
BM 903.671-673; R 636765→		624 3182 33
BM 903.671-673; A 920787→		
SAC		
BM 903.611 / .612 / .613 903.621 / .622 / .623; R 636765→		624 3182 33
BM 903.611 / .612 / .613 903.621 / .622 / .623; A 920787→		
SAC		
BM 903.661 / .662 / .663; R 636765→; →SEQU		624 3182 34
BM 903.661 / .662 / .663; A 920787→; →SEQU		
SAC		
BM 903.611 / .612 / .613 903.621 / .622 / .623; R 636765→; →SEQU		624 3182 34
BM 903.611 / .612 / .613 903.621 / .622 / .623; A 920787→; →SEQU		
SAC		
BM 903.671-673; R 636765→; →SEQU		624 3182 34
BM 903.671-673; A 920787→; →SEQU		
SAC		
BM 903.611 / .612 / .613 903.621 / .622 / .623; + 624 3182 09/33/34		415 0239 10
BM 903.671-673; + 624 3182 09/33/34		415 0239 10
BM 903.661 / .662 / .663; + 624 3182 09/33/34		415 0239 10



; A/C ; + ; # F-228824.XX		529 0333 10
A/C ;		532 0391 20
; A/C ; (- HA)		532 0108 10
; 2x		532 0160 10
		533 0017 10
# F-228824.XX		535 0015 10
# F-233197.XX F-559320.XX		535 0050 10
		544 0116 10
; →R220797; A/C		FB 6PK2196
; R220798→; A/C		FB 6PK2264
; A/C		FB 6PK2270
		538 0220 10
16x 33 mm		420 0170 10
		428 0092 10
		428 0184 10
1x		553 0296 10
1x		559 0039 10



		713 6670 10
		713 6670 30
84 mm		772 0126 30
		815 0063 30
right;		818 0183 10
right;		818 0186 10
left;		818 0182 10
left;		818 0185 10





MERCEDES-BENZ

Sprinter (903) 3-t					
313 CDI 4x4 OM 611.981; (95kW)	08.02-05.06	FAG			818 0177 10
				840 0151 10	
314 4x4 M 111.984; (105kW)	08.02-05.06	LUK			840 1173 10
					600 0065 00
					600 0065 00
					600 0065 00
					624 2187 00
					624 2187 00
					624 2187 00
					624 3148 09
					624 3148 33
					624 3148 33
					624 3148 33
					624 3148 34
					624 3148 34
					624 3182 09
					624 3182 33
					624 3182 33
					624 3182 34
					624 3182 34
					624 3182 34
					624 3182 34
					624 3182 34
					415 0196 10
					415 0196 10
					415 0196 10
					415 0247 10
					415 0247 10
					415 0247 10
					411 0147 10
					411 0147 10
					411 0147 10



			<p>SCHAEFFLER</p>	
--	--	--	--------------------------	--

MERCEDES-BENZ

Sprinter (903) 3-t

314 4x4
 M 111.984; (105kW)

08.02-05.06



			531 0551 20
			533 0055 20
	+ 533 0055 20		533 0084 30
	→000441; A/C		FB 6PK2100
	000442→; A/C		FB 6PK2115
	002 029→; A/C; MANU		FB 6PK2115
	000 442→; A/C; AUTOM		FB 6PK2215
	A/C		538 0248 10
	16x		420 0042 10
	35 mm		
	1x		OILP 553 0296 10
	1x		KIT 559 0046 10
	FAG		Set 713 6670 10
	84 mm		Set 713 6670 30
			SET 772 0126 30
			REP 815 0063 30
	right;		818 0183 10
	right;		818 0186 10
	left;		818 0182 10
	left;		818 0185 10
			818 0177 10
			840 0151 10
			840 1173 10

316 CDI 4x4
 OM 612.981; OM 647.981;
 (115kW)

08.02-05.06

















































































	BM 903.611/612/612 903.621/622; SEU		600 0060 00
	incl. O; incl. SEU; SAC		
	BM 903.671-673; SEU		600 0060 00
	incl. O; incl. SEU; SAC		
	BM 903.661/662/663; SEU		600 0060 00
	incl. O; incl. SEU; SAC		
	BM 903.671-673; →R 636764		624 3148 33
	BM 903.671-673; →A 920786		
	SAC		
	BM 903.661 / .662 / .663; →R 636764		624 3148 33
	BM 903.661 / .662 / .663; →A 920786		
	SAC		
	BM 903.611 / .612 / .613 903.621 / .622 / .623; →R 636764		624 3148 33
	BM 903.611 / .612 / .613 903.621 / .622 / .623; →A 920786		
	SAC		
	BM 903.671-673; →R 636764; SEU		624 3148 34
	BM 903.671-673; →A 920786; SEU		
	SAC		
	BM 903.611 / .612 / .613 903.621 / .622 / .623;		624 3148 34
	→R 636764; SEU		
	BM 903.611 / .612 / .613 903.621 / .622 / .623;		624 3148 34
	→A 920786; SEU		
	SAC		
	BM 903.661 / .662 / .663; →R 636764; SEU		624 3148 34
	BM 901.661 / .662 / .663; →A 920786; SEU		
	SAC		
	BM 903.661 / .662 / .663; R 636765→		624 3182 33
	BM 903.661 / .662 / .663; A 920787→		
	SAC		
	BM 903.671-673; R 636765→		624 3182 33
	BM 903.671-673; A 920787→		
	SAC		
	BM 903.611 / .612 / .613 903.621 / .622 / .623; R 636765→		624 3182 33
	BM 903.611 / .612 / .613 903.621 / .622 / .623; A 920787→		
	SAC		
	BM 903.611 / .612 / .613 903.621 / .622 / .623;		624 3182 34
	R 636765→; SEU		
	BM 903.611 / .612 / .613 903.621 / .622 / .623;		624 3182 34
	A 920787→; SEU		
	SAC		
	BM 903.661 / .662 / .663; R 636765→; SEU		624 3182 34
	BM 903.661 / .662 / .663; A 920787→; SEU		
	SAC		



















































			SCHAEFFLER
--	---	--	-------------------

MERCEDES-BENZ

Sprinter (903) 3-t

316 CDI 4x4 OM 612.981; OM 647.981; (115kW)	08.02-05.06		 BM 903-671-673;  R 636765→;  SEQU		624 3182 34	
			 BM 903.671-673;  A 920787→;  SEQU SAC			
			 BM 903.661 /.662/.663; + 624 3182 09/33/34		415 0243 10	
			 BM 903.671-673; + 624 3182 09/33/34		415 0243 10	
			 BM 903.611 /.612/.613 903.621 /.622/.623; + 624 3182 09/33/34		415 0243 10	
					411 0160 10	
				 ; A/C ;  ;  # F-228824.XX		529 0333 10
				A/C ; 		532 0391 20
				 ; A/C ; (- HA)		532 0108 10
				 ; 2x		532 0160 10
					533 0017 10	
		 # F-228824.XX			535 0015 10	
		 # F-233197.XX F-559320.XX			535 0050 10	
		Ø 216 mm;  ;  →50 076683			544 0111 10	
		 ;  →R220797; A/C			FB 6PK2196	
		 ;  R220798→; A/C			FB 6PK2264	
		 A/C		FB 6PK2270		
		 ; A/C		FB 6PK2270		
		→01.04		538 0220 10		
		02.04→		538 0238 10		
		20x		420 0170 10		
		 33 mm				
		1x		553 0296 10		
		1x		559 0039 10		
		FAG			713 6670 10	
			 84 mm		713 6670 30	
					772 0126 30	
					815 0063 30	
			 right; 		818 0183 10	
			 right; 		818 0186 10	
			 left; 		818 0182 10	
			 left; 		818 0185 10	
					818 0177 10	
					840 0151 10	
		840 1173 10				

Sprinter (905)























































513 CDI (906.653, 906.655, 906.657) OM 651.955; (95kW)	06.06-		 incl. 		600 0291 00
			SAC		624 3408 33
					415 0660 10
					411 0150 10
			 # F-232001.XX		535 0042 10
			 # F-233197.XX F-559320.XX		535 0050 10
			 # F-552901.XX		535 0168 10
			16x		420 0225 10
		 12 mm			
		16x		422 0099 10	
		FAG	 ;  → 1.850 kg		713 6680 10
			 96 mm		
			 ;  1.850 kg →		713 6680 20
			 96 mm		
			713 6680 40		
 right			818 0336 10		
 left		818 0335 10			
 ↔		840 0373 10			
 ↔		840 1111 10			
	03.09-	16x		420 0225 10	
		 12 mm			
		16x		422 0099 10	
		FAG	 ;  → 1.850 kg		713 6680 10
 96 mm					
 ;  1.850 kg →			713 6680 20		
 96 mm					
		713 6680 40			



			SCHAEFFLER
--	---	--	-------------------

MERCEDES-BENZ

Sprinter (905)





516 CDI OM 651.957; (120kW)	03.09-	FAG	right		818 0336 10
			left		818 0335 10
519 CDI / BlueTEC OM 642.896; OM 642.898; OM 642.992; (140kW)	03.09-	INA	START/STOP		529 0050 10
			2x		532 0234 10
			A/C		532 0566 10
			OM 642.992		534 0183 10
			A/C		534 0257 10
			START/STOP; OM 642.896 OM 642.898		534 0506 10
			F-239808.XX		535 0140 10
			HYDP; A/C		FB 6PK1413
			A/C; # OE 0019933696		FB 7PK1973
			P70; A/C		FB 7PK2035
			24x		420 0086 10
			12 mm		
			24x		422 0056 10
			1x; 642.896 642.898; →04.15; →41711428		558 0039 10
			1x; 642.992; →09.14; →41633498		
			1x; 642.896 642.898; →04.15; →41711428		559 0087 10
			1x; 642.992; →09.14; →41633498		
			1x; 642.896 642.898; →04.15; →41711428		559 0088 10
			1x; 642.992; →09.14; →41633498		
			1x		558 0040 10
FAG	FAG	→ 1.850 kg		713 6680 10	
		96 mm		713 6680 20	
		→ 1.850 kg		713 6680 40	
		96 mm			
		right		818 0336 10	
		left		818 0335 10	
		↔		840 0373 10	
		↔		840 1111 10	
		→R 636764 SAC		624 3148 33	
		R 636765 → SAC		624 3182 33	
624 3182 09/33		415 0243 10			
INA	INA	A/C		532 0108 10	
		2x		532 0160 10	
				533 0017 10	
		F-228824.XX		535 0015 10	
		F-233197.XX F-559320.XX		535 0050 10	
		Ø 216 mm; →50 076683		544 0111 10	
		A/C		FB 6PK2264	
		A/C		FB 6PK2270	
		20x		538 0220 10	
		33 mm		420 0170 10	
1x		553 0296 10			
1x		559 0039 10			
FAG	FAG	80 mm		33109	
		52 mm		33205	
		↓down		814 0039 10	
		↑up		814 0038 10	
		right		818 0186 10	
		left		818 0185 10	
		↔		840 0373 10	
		↔			
616 CDI (905.612, 905.613, 905.622, 905.623) OM 612.981; (115kW)	04.01-05.06	LUK	→R 636764 SAC		624 3148 33
			R 636765 → SAC		624 3182 33
616 CDI (905.612, 905.622, 905.623) OM 612.981; (115kW)	04.01-	LUK	624 3182 09/33		415 0243 10
			A/C		532 0108 10
616 CDI (905.612, 905.622, 905.623) OM 612.981; (115kW)	04.01-	INA	2x		532 0160 10
					533 0017 10



			SCHAEFFLER
--	--	--	-------------------

MERCEDES-BENZ

Sprinter (905)				
616 CDI (905.612, 905.622, 905.623) OM 612.981; (115kW)	04.01-		6# F-233197.XX F-559320.XX Ø 216 mm; → 50 076683 ; A/C ; A/C 20x 33 mm 1x 1x	535 0050 10 544 0111 10 FB 6PK2264 FB 6PK2270 538 0220 10 420 0170 10 OILP 553 0296 10 KIT 559 0039 10
		FAG	80 mm 52 mm	33109 33205



Sprinter (906) 3-t - 5-t				
209 CDI (906.111, 906.113, 906.211, 906.213) OM 646.984; (65kW)	06.06-12.09		G6 ; NSG 400 ; ID 711.660; Z 515.401/08 Z 515.401/09 G6 ; NSG 400 ; ID 711.660; Z 515.401/06 G6 ; TSG 360 ; ID 711.680 incl. ; incl. , SAC SAC	GearBOX 462 0238 10 GearBOX 462 0313 10 GearBOX 462 0332 10 600 0255 00 624 3247 33 415 0309 10 411 0147 10
			A/C ; ; 2x ; OPTION ; 6# F-233197.XX F-559320.XX 6# F-552901.XX ; A/C ; R220798 → ; A/C ; PTO 16x 33 mm 1x 1x	532 0391 20 532 0160 10 533 0017 10 534 0481 10 535 0050 10 535 0168 10 544 0116 10 FB 6PK2260 FB 6PK2264 FB 6PK2280 538 0224 10 420 0170 10 428 0092 10 428 0184 10 OILP 553 0147 10 KIT 559 0039 10
		FAG	right left ; → 1.850 kg 96 mm ; 1.850 kg → 96 mm ; BM 906.132 906.134 906.136 right left ; ↔ ↔ 840 1111 10	821 0700 10 821 0699 10 Set 713 6680 10 Set 713 6680 20 Set 713 6681 10 818 0336 10 818 0335 10 818 0447 10 825 0327 10 840 0373 10 840 1111 10
209 CDI (906.611, 906.613) OM 646.984; (65kW)	06.06-12.09		G6 ; NSG 370 ; ID 711.651 G6 ; NSG 400 ; ID 711.660; Z 515.401/08 Z 515.401/09 G6 ; NSG 400 ; ID 711.660; Z 515.401/06 G6 ; TSG 360 ; ID 711.680 incl. ; incl. , SAC SAC	GearBOX 462 0152 10 GearBOX 462 0238 10 GearBOX 462 0313 10 GearBOX 462 0332 10 600 0255 00 624 3247 33 415 0309 10 411 0147 10
			; A/C A/C ; ; 2x ; OPTION ; 6# F-233197.XX F-559320.XX 6# F-552901.XX	529 0115 10 532 0391 20 532 0160 10 533 0017 10 534 0481 10 535 0050 10 535 0168 10



			<p>SCHAEFFLER</p>
--	--	--	--------------------------

MERCEDES-BENZ

Sprinter (906) 3-t - 5-t

<p>209 CDI (906.611, 906.613) OM 646.984; (65kW)</p>	<p>06.06-12.09</p>		<p>PTO</p> <p>PTO</p> <p>16x 33 mm</p> <p>1x 1x</p> <p>FAG</p> <p>right left → 1.850 kg 96 mm 1.850 kg → 96 mm BM 906.132 906.134 906.136</p> <p>right left → →</p>	<p>544 0116 10 FB 6PK2260 FB 6PK2285 538 0224 10 420 0170 10 428 0092 10 428 0184 10 OILP 553 0147 10 SKIT 559 0039 10 821 0700 10 821 0699 10 Set 713 6680 10 Set 713 6680 20 Set 713 6681 10 818 0336 10 818 0335 10 818 0447 10 825 0327 10 840 0373 10 840 1111 10 600 0291 00</p>
<p>210 CDI (906.111, 906.113, 906.211, 906.213, 906.611, 906.613, 906.711, 906.713) OM 651.955; (70kW)</p>	<p>03.09-</p>		<p>incl. ○ SAC</p> <p>INA A</p> <p>START/STOP A/C A/C</p> <p>START/STOP START/STOP</p> <p>F-233197.XX F-559320.XX F-552901.XX</p> <p>START/STOP →08.10; →S 495102; START/STOP</p> <p>16x 12 mm</p> <p>16x</p> <p>FAG</p> <p>right left → 1.850 kg 96 mm 1.850 kg → 96 mm BM 906.132 906.134 906.136</p> <p>right left → →</p>	<p>624 3408 33 415 0660 10 411 0150 10 KIT 529 0361 10 532 0108 10 532 0570 10 532 0608 10 532 0671 10 532 0672 10 534 0337 10 534 0444 10 535 0050 10 535 0168 10 FB 6PK2215 538 0221 10 420 0225 10 422 0099 10 821 0700 10 821 0699 10 Set 713 6680 10 Set 713 6680 20 Set 713 6681 10 818 0336 10 818 0335 10 818 0447 10 825 0327 10 840 0373 10 840 1111 10</p>
<p>211 CDI (906.111, 906.113, 906.211, 906.213) OM 646.985; (80kW)</p>	<p>06.06-12.09</p>		<p>G6 ; NSG 370 ; ID 711.651 G6 ; NSG 400 ; ID 711.660; Z 515.401/08 Z 515.401/09 G6 ; NSG 400 ; ID 711.660; Z 515.401/06 G6 ; TSG 360 ; ID 711.680</p> <p>incl. ○; incl. ; SAC</p> <p>SAC</p> <p>INA A</p> <p>A/C</p>	<p>GearBOX 462 0152 10 GearBOX 462 0238 10 GearBOX 462 0313 10 GearBOX 462 0332 10 600 0255 00 624 3247 33 415 0309 10 411 0147 10 KIT 529 0115 10</p>





MERCEDES-BENZ

Sprinter (906) 3-t - 5-t



























































<p>211 CDI (906.111, 906.113, 906.211, 906.213) OM 646.985; (80kW)</p>	<p>06.06-12.09</p>	<p></p>	<p>A/C ; </p> <p> ; 2x</p> <p> ; OPTION</p> <p></p> <p> # F-233197.XX F-559320.XX</p> <p> # F-552901.XX</p> <p> ; A/C</p> <p> ; A/C</p> <p>16x 33 mm</p> <p></p> <p></p> <p>1x OILP</p> <p>1x KIT</p> <p>FAG</p> <p> right</p> <p> left</p> <p> ; → 1.850 kg 96 mm</p> <p> ; 1.850 kg → 96 mm</p> <p> ; ; BM 906.132 906.134 906.136</p> <p> right</p> <p> left</p> <p> ; </p> <p> ↔</p> <p> ↔</p> <p></p>	<p> 532 0391 20</p> <p> 532 0108 10</p> <p> 532 0160 10</p> <p> 533 0017 10</p> <p> 534 0481 10</p> <p> 535 0050 10</p> <p> 535 0168 10</p> <p> 544 0116 10</p> <p> FB 6PK2260</p> <p> FB 6PK2285</p> <p> 538 0224 10</p> <p> 420 0170 10</p> <p> 428 0092 10</p> <p> 428 0184 10</p> <p> 553 0147 10</p> <p> 559 0039 10</p> <p> 821 0700 10</p> <p> 821 0699 10</p> <p> Set 713 6680 10</p> <p> Set 713 6680 20</p> <p> Set 713 6681 10</p> <p> 818 0336 10</p> <p> 818 0335 10</p> <p> 818 0447 10</p> <p> 825 0327 10</p> <p> 840 0373 10</p> <p> 840 1111 10</p> <p>GearBOX 462 0152 10</p> <p> 600 0291 00</p> <p> 624 3408 33</p> <p> 415 0660 10</p> <p> 411 0150 10</p> <p> 535 0050 10</p> <p> 535 0168 10</p> <p> FB 6PK2215</p> <p> 420 0225 10</p> <p> 422 0099 10</p> <p> Set 713 6680 10</p> <p> Set 713 6680 20</p> <p> Set 713 6681 10</p> <p> 818 0336 10</p> <p> 818 0335 10</p> <p> 818 0447 10</p> <p> 840 0373 10</p> <p> 840 1111 10</p>
<p>211 CDI (906.111, 906.113, 906.211, 906.213) OM 651.955; (84kW)</p>	<p>04.16-</p>	<p></p> <p></p> <p>FAG</p>	<p>G6 ; NSG 370 ; ID 711.651</p> <p></p> <p>incl. </p> <p>SAC</p> <p></p> <p> # F-233197.XX F-559320.XX</p> <p> # F-552901.XX</p> <p> ; START/STOP</p> <p>16x 12 mm</p> <p>16x</p> <p> ; → 1.850 kg 96 mm</p> <p> ; 1.850 kg → 96 mm</p> <p> ; ; BM 906.132 906.134 906.136</p> <p> right</p> <p> left</p> <p> ; </p> <p> ↔</p> <p> ↔</p> <p></p>	<p>GearBOX 462 0152 10</p> <p> 600 0291 00</p> <p> 624 3408 33</p> <p> 415 0660 10</p> <p> 411 0150 10</p> <p> 535 0050 10</p> <p> 535 0168 10</p> <p> FB 6PK2215</p> <p> 420 0225 10</p> <p> 422 0099 10</p> <p> Set 713 6680 10</p> <p> Set 713 6680 20</p> <p> Set 713 6681 10</p> <p> 818 0336 10</p> <p> 818 0335 10</p> <p> 818 0447 10</p> <p> 840 0373 10</p> <p> 840 1111 10</p>
<p>211 CDI (906.611, 906.613) OM 646.985; (80kW)</p>	<p>06.06-12.09</p>	<p></p> <p></p>	<p>G6 ; NSG 370 ; ID 711.651</p> <p>G6 ; NSG 400 ; ID 711.660 ; Z 515.401/08 Z 515.401/09</p> <p>G6 ; NSG 400 ; ID 711.660 ; Z 515.401/06</p> <p>G6 ; TSG 360 ; ID 711.680</p> <p>incl. ; incl. ; SAC</p> <p>SAC</p> <p></p> <p></p> <p></p> <p> ; A/C</p> <p>A/C ; </p> <p></p> <p> ; 2x</p> <p> ; OPTION</p> <p></p>	<p>GearBOX 462 0152 10</p> <p>GearBOX 462 0238 10</p> <p>GearBOX 462 0313 10</p> <p>GearBOX 462 0332 10</p> <p> 600 0255 00</p> <p> 624 3247 33</p> <p> 415 0309 10</p> <p> 411 0147 10</p> <p> KIT 529 0115 10</p> <p> 532 0391 20</p> <p> 532 0108 10</p> <p> 532 0160 10</p> <p> 533 0017 10</p> <p> 534 0481 10</p>



			SCHAEFFLER
--	--	--	-------------------

MERCEDES-BENZ



























































































































Sprinter (906) 3-t - 5-t

<p>211 CDI (906.611, 906.613) OM 646.985; (80kW)</p>	<p>06.06-12.09</p>	<p></p>	<p>№# F-233197.XX F-559320.XX №# F-552901.XX</p> <p>16x 33 mm</p> <p>1x</p> <p>1x</p> <p>FAG right left → 1.850 kg 96 mm → 1.850 kg 96 mm BM 906.132 906.134 906.136 right left ↔ ↔</p>	<p> 535 0050 10  535 0168 10  544 0116 10  FB 6PK2260  FB 6PK2285  538 0224 10  420 0170 10  428 0092 10  428 0184 10  OILP 553 0147 10  KIT 559 0039 10  821 0700 10  821 0699 10  Set 713 6680 10  Set 713 6680 20  Set 713 6681 10  818 0336 10  818 0335 10  818 0447 10  825 0327 10  840 0373 10  840 1111 10</p>
<p>211 CDI (906.611, 906.613) OM 651.955; (84kW)</p>	<p>04.16-</p>	<p></p> <p></p> <p>FAG</p>	<p>G6 ; NSG 370 ; ID 711.651 S559085 → ; incl. ○ S 559085 → SAC S559085 → SAC</p> <p>№# F-233197.XX F-559320.XX №# F-552901.XX START/STOP</p> <p>16x 12 mm</p> <p>16x</p> <p>→ 1.850 kg 96 mm → 1.850 kg 96 mm BM 906.132 906.134 906.136 right left ↔ ↔</p>	<p>GearBOX 462 0152 10  600 0291 00  624 3408 09  624 3408 33  415 0660 10  411 0150 10  535 0050 10  535 0168 10  FB 6PK2215  420 0225 10  422 0099 10  Set 713 6680 10  Set 713 6680 20  Set 713 6681 10  818 0336 10  818 0335 10  818 0447 10  840 0373 10  840 1111 10</p>
<p>211 CDI (906.711, 906.713) OM 646.985; (80kW)</p>	<p>06.06-12.09</p>	<p></p> <p></p>	<p>G6 ; NSG 370 ; ID 711.651 G6 ; NSG 400 ; ID 711.660 ; Z 515.401/08 Z 515.401/09 G6 ; NSG 400 ; ID 711.660 ; Z 515.401/06 incl. ○ ; incl. ; SAC SAC</p> <p>A/C A/C ; 2x OPTION F-233197.XX F-559320.XX F-552901.XX A/C</p>	<p>GearBOX 462 0152 10 GearBOX 462 0238 10 GearBOX 462 0313 10  600 0255 00  624 3247 33  415 0309 10  411 0147 10  529 0115 10  532 0391 20  532 0108 10  532 0160 10  533 0017 10  534 0481 10  535 0050 10  535 0168 10  544 0116 10  FB 6PK2260</p>



			SCHAEFFLER
--	---	--	-------------------

MERCEDES-BENZ

















































































































































Sprinter (906) 3-t - 5-t						
211 CDI (906.711, 906.713) OM 646.985; (80kW)	06.06-12.09		 ; A/C	 FB 6PK2285		
			 16x  33 mm	 538 0224 10  420 0170 10		
				 428 0092 10  428 0184 10		
				 553 0147 10		
			1x	 OILP 559 0039 10		
			1x	 KIT 821 0700 10  821 0699 10  Set 713 6680 10		
			 right	 713 6680 20		
			 left  → 1.850 kg  96 mm	 Set 713 6681 10		
			 1.850 kg →  96 mm  BM 906.132 906.134 906.136	 818 0336 10  818 0335 10  818 0447 10		
			 right  left 	 825 0327 10  840 0373 10  840 1111 10		
		 ↔  ↔ 	 GearBOX 462 0152 10  600 0291 00			
			 G6 ;  NSG 370 ;  ID 711.651 incl.   SAC	 624 3408 33  415 0660 10  411 0150 10		
			04.16-	 # F-233197.XX F-559320.XX  # F-552901.XX  START/STOP	 535 0050 10  535 0168 10  FB 6PK2215  420 0225 10	
				 16x  12 mm	 422 0099 10	
				 16x  → 1.850 kg  96 mm	 Set 713 6680 10	
				 1.850 kg →  96 mm  BM 906.132 906.134 906.136	 Set 713 6680 20  Set 713 6681 10	
				 right  left 	 818 0336 10  818 0335 10  818 0447 10	
				 ↔  ↔	 840 0373 10  840 1111 10	
					 SA 522609 08 incl.   SAC	 600 0255 00  600 0260 00
				 SA 522609 11 incl.   SAC SAC	 624 3247 33  415 0309 10	
 SA 522609 08  SA 522609 11	 411 0147 10  411 0160 10					
	06.06-12.09			A/C ; 	 532 0391 20	
		 ; 2x	 532 0160 10			
		 ; OPTION	 533 0017 10  534 0481 10			
		 # F-233197.XX F-559320.XX  # F-552901.XX	 535 0050 10  535 0168 10  544 0116 10			
		 ; A/C	 FB 6PK2260  FB 6PK2285			
		 ; 2x   BM =2ND ACC	 FB 13X975  538 0224 10			
		A/C	 420 0170 10			
		 16x  33 mm	 428 0092 10  428 0184 10			
			 553 0147 10			
			 OILP			



			SCHAEFFLER
--	---	--	-------------------

MERCEDES-BENZ

Sprinter (906) 3-t - 5-t

213 CDI (906.111, 906.113, 906.211, 906.213) OM 646.986; (95kW)	06.06-12.09	 FAG	1x		559 0039 10	
			 right		821 0700 10	
			 left		821 0699 10	
			 ;  → 1.850 kg		713 6680 10	
			 96 mm			
			 ;  1.850 kg →		713 6680 20	
			 96 mm			
			 ;  ;  ;  BM 906.132 906.134 906.136		713 6681 10	
			 right		818 0336 10	
			 left		818 0335 10	
			 ; 		818 0447 10	
			 ↔		825 0327 10	
			 ↔		840 0373 10	
					840 1111 10	
			213 CDI (906.111, 906.113, 906.211, 906.213) OM 651.955; OM 651.957; (95kW)	03.09-05.16		 incl. 
		624 3408 33				
		415 0660 10				
		411 0150 10				
  ; START/STOP A/C		529 0361 10				
 ; A/C		532 0108 10				
 ; 		532 0570 10				
 ; 		532 0608 10				
		532 0671 10				
		532 0672 10				
 ; START/STOP		534 0337 10				
 ; START/STOP		534 0444 10				
 # F-233197.XX F-559320.XX		535 0050 10				
 # F-552901.XX		535 0168 10				
 ; START/STOP		FB 6PK2215				
 ; →08.10;  →S 495102; START/STOP		FB 6PK2260				
 ; EURO 4 ; A/C START/STOP		FB 6PK2285				
 ; PTO ; START/STOP		538 0221 10				
		420 0225 10				
16x						
 12 mm						
16x		422 0099 10				
FAG	 right				821 0700 10	
	 left				821 0699 10	
	 ;  → 1.850 kg				713 6680 10	
	 96 mm					
	 ;  1.850 kg →				713 6680 20	
	 96 mm					
	 ;  ;  ;  BM 906.132 906.134 906.136				713 6681 10	
	 right				818 0336 10	
	 left		818 0335 10			
	 ; 		818 0447 10			
	 ↔		825 0327 10			
	 ↔		840 0373 10			
			840 1111 10			
		06.06-		 incl. 		600 0291 00
						624 3408 33
					415 0660 10	
					411 0150 10	
  ; START/STOP A/C					529 0361 10	
 ; A/C					532 0108 10	
 ; 					532 0570 10	
 ; 					532 0608 10	
					532 0671 10	
					532 0672 10	
 ; START/STOP					534 0337 10	
 ; START/STOP					534 0444 10	
 # F-233197.XX F-559320.XX					535 0050 10	
 ; 03.09 → ; START/STOP					FB 6PK2215	
 ; 03.09 → 08.10;  →S 495102; START/STOP						





MERCEDES-BENZ

Sprinter (906) 3-t - 5-t

213 CDI (906.611, 906.613)
 OM 651.955; OM 651.957; (95kW)

06.06-

	16x 12 mm		420 0225 10
FAG	16x → 1.850 kg 96 mm		422 0099 10 713 6680 10
	1.850 kg → 96 mm		713 6680 20
	BM 906.132 906.134 906.136		713 6681 10
			818 0447 10
			825 0327 10
			840 0373 10
			840 1111 10

213 CDI (906.611, 906.613)
 OM 646.986; (95kW)

06.06-12.09

LUK	SA 522609 08 incl. ; incl. ; SAC		600 0255 00
	SA 522609 11 incl. ; incl. ; SAC		600 0260 00
	SAC		624 3247 33
			415 0309 10
	SA 522609 08		411 0147 10
	SA 522609 11		411 0160 10
	; A/C		529 0115 10
	A/C;		532 0391 20
	; 2x		532 0160 10
	; OPTION		533 0017 10
			534 0481 10
	# F-233197.XX F-559320.XX		535 0050 10
	# F-552901.XX		535 0168 10
			544 0116 10
	; A/C		FB 6PK2260
	; A/C		FB 6PK2285
			538 0224 10
	16x 33 mm		420 0170 10
			428 0092 10
			428 0184 10
	1x		553 0147 10
	1x		559 0039 10
FAG	right		821 0700 10
	left		821 0699 10
	→ 1.850 kg 96 mm		713 6680 10
	1.850 kg → 96 mm		713 6680 20
	BM 906.132 906.134 906.136		713 6681 10
	right		818 0336 10
	left		818 0335 10
			818 0447 10
			825 0327 10
			840 0373 10
			840 1111 10
			600 0291 00

213 CDI (906.711, 906.713)
 OM 651.955; (95kW)

06.06-05.16

























































































































LUK	 incl. SAC		624 3408 33
			415 0660 10
			411 0150 10
	; START/STOP A/C		529 0361 10
	; A/C		532 0108 10
			532 0570 10
			532 0608 10
			532 0671 10
			532 0672 10
	; START/STOP		534 0337 10
	; START/STOP		534 0444 10
	# F-233197.XX F-559320.XX		535 0050 10
	; START/STOP		FB 6PK2215
	; →08.10; →S 495102; START/STOP		FB 6PK2285
	; START/STOP		FB 6PK2285



			SCHAEFFLER
--	--	--	-------------------

MERCEDES-BENZ



























































































































Sprinter (906) 3-t - 5-t

213 CDI (906.711, 906.713) OM 651.955; (95kW)	06.06-05.16	 FAG	16x  12 mm		420 0225 10
			16x  ;  → 1.850 kg  96 mm	 Set	422 0099 10 713 6680 10
			 ;  1.850 kg →  96 mm	 Set	713 6680 20
			 ;  ;  ;  BM 906.132 906.134 906.136	 Set	713 6681 10
			 ; 		818 0447 10
			 ↔		825 0327 10
			 ↔		840 0373 10
					840 1111 10
					600 0291 00
					624 3408 33
					415 0660 10
					411 0150 10
			 # F-233197.XX F-559320.XX # F-552901.XX ; START/STOP	  	535 0050 10 535 0168 10 FB 6PK2215
			16x  12 mm		420 0225 10
			16x  ;  → 1.850 kg  96 mm	 Set	422 0099 10 713 6680 10
 ;  1.850 kg →  96 mm	 Set	713 6680 20			
 ;  ;  BM 906.132 906.134 906.136	 Set	713 6681 10			
 right		818 0336 10			
 left		818 0335 10			
 ; 		818 0447 10			
 ↔		840 0373 10			
 ↔		840 1111 10			
215 CDI (906.111, 906.113, 906.211, 906.213) OM 646.986; OM 646.989; OM 646.990; (110kW)	06.06-12.09	LUK	G6 ;  NSG 370 ;  ID 711.651	GearBOX	462 0152 10
			G6 ;  NSG 400 ;  ID 711.660;	GearBOX	462 0238 10
			 Z 515.401/08 Z 515.401/09		
			G6 ;  NSG 400 ;  ID 711.660;  Z 515.401/06	GearBOX	462 0313 10
			G6 ;  TSG 360 ;  ID 711.680	GearBOX	462 0332 10
			 SA 522609 08 SA 522609 09		600 0255 00
			incl.  ; incl.  ; SAC		600 0260 00
			 OM 646.986;  SA 522609 11		624 3247 33
			incl.  ; incl.  ; SAC		415 0309 10
			SAC		624 3247 33
			 SA 522609 08 SA 522609 09		411 0147 10
			 OM 646.986;  SA 522609 11		411 0160 10
			 A/C ;  ; 2x ; OPTION  # F-233197.XX F-559320.XX # F-552901.XX ; A/C		532 0391 20
					532 0160 10
					533 0017 10
				534 0481 10	
				535 0050 10	
				535 0168 10	
				544 0116 10	
				FB 6PK2260	
				538 0224 10	
				420 0170 10	
		16x  33 mm		428 0092 10	
				428 0184 10	
		1x		553 0147 10	
1x		559 0039 10			
FAG	 right		821 0700 10		
	 left		821 0699 10		
	 ;  → 1.850 kg  96 mm	 Set	713 6680 10		
	 ;  1.850 kg →  96 mm	 Set	713 6680 20		



			SCHAEFFLER
--	---	--	-------------------

MERCEDES-BENZ

Sprinter (906) 3-t - 5-t				
215 CDI (906.111, 906.113, 906.211, 906.213) OM 646.986; OM 646.989; OM 646.990; (110kW)	06.06-12.09	FAG	 right  left  ;   ↔  ↔ 	 BM 906.132 906.134 906.136  Set 713 6681 10  818 0336 10  818 0447 10  825 0327 10  840 0373 10  840 1111 10
			LUK G6 ;  NSG 400 ;  ID 711.660;  Z 515.401/08 Z 515.401/09 G6 ;  NSG 400 ;  ID 711.660;  Z 515.401/06 G6 ;  TSG 360 ;  ID 711.680  SA 522609 08 SA 522609 09 incl. ☉; incl.  ; SAC  OM 646.986;  SA 522609 11 incl. ☉; incl.  ; SAC SAC  SA 522609 08 SA 522609 09  OM 646.986;  SA 522609 11  SA 522609 08 SA 522609 09  OM 646.986;  SA 522609 11 A/C ;  A/C  ; 2x  ; OPTION   # F-233197.XX F-559320.XX  # F-552901.XX  ; A/C  ; 2x   ;  BM =2ND ACC A/C 16x  33 mm   1x 1x FAG  right  left  ;  → 1.850 kg  96 mm  ;  1.850 kg →  96 mm  ;  BM 906.132 906.134 906.136  right  left  ;   ↔  ↔ 	 GearBOX 462 0238 10  GearBOX 462 0313 10  GearBOX 462 0332 10  600 0255 00  600 0260 00  624 3247 33  415 0309 10  411 0147 10  411 0160 10  532 0391 20  532 0160 10  533 0017 10  534 0481 10  535 0050 10  535 0168 10  544 0116 10  FB 6PK2260  FB 6PK2285  FB 13X975  538 0224 10  420 0170 10  428 0092 10  428 0184 10  OILP 553 0147 10  KIT 559 0039 10  821 0700 10  821 0699 10  Set 713 6680 10  Set 713 6680 20  Set 713 6681 10  818 0336 10 818 0335 10 818 0447 10 825 0327 10 840 0373 10 840 1111 10
215 CDI (906.711, 906.713) OM 646.986; OM 646.989; OM 646.990; (110kW)	06.06-12.09	LUK	G6 ;  NSG 370 ;  ID 711.651 G6 ;  NSG 400 ;  ID 711.660;  Z 515.401/08 Z 515.401/09 G6 ;  NSG 400 ;  ID 711.660;  Z 515.401/06  SA 522609 08 SA 522609 09 incl. ☉; incl.  ; SAC  OM 646.986;  SA 522609 11 incl. ☉; incl.  ; SAC SAC  SA 522609 08 SA 522609 09  OM 646.986;  SA 522609 11 A/C ; A/C A/C ;  A/C ; 2x ; OPTION 	 GearBOX 462 0152 10  GearBOX 462 0238 10  GearBOX 462 0313 10  600 0255 00  600 0260 00  624 3247 33  415 0309 10  411 0147 10  411 0160 10  529 0115 10  532 0391 20 532 0160 10 533 0017 10 534 0481 10



			SCHAEFFLER
--	---	--	-------------------

MERCEDES-BENZ

Sprinter (906) 3-t - 5-t

215 CDI (906.711, 906.713)
 OM 646.986; OM 646.989; OM 646.990; (110kW)

06.06-12.09



	№# F-233197.XX F-559320.XX		535 0050 10
	№# F-552901.XX		535 0168 10
			544 0116 10
			FB 6PK2260
			538 0224 10
			420 0170 10
	16x		
	33 mm		
			428 0092 10
			428 0184 10
	1x		OILP 553 0147 10
	1x		SKIT 559 0039 10
FAG	right		821 0700 10
	left		821 0699 10
	; → 1.850 kg		Set 713 6680 10
	96 mm		
	; 1.850 kg →		Set 713 6680 20
	96 mm		
	; ; BM 906.132 906.134 906.136		Set 713 6681 10
	right		818 0336 10
	left		818 0335 10
	;		818 0447 10
	↔		825 0327 10
	↔		840 0373 10
			840 1111 10

216 (906.113, 906.213)
 M 271.951; (115kW)

09.08-05.16



LUK	SAC		624 3247 33
			415 0293 10
			411 0154 10
			532 0401 30
			532 0648 10
	; →03.09; →31216219		534 0081 30
	; 03.09→; 31216220→		534 0370 10
	№# F-232001.XX		535 0042 10
	№# F-557311.XX		535 0165 10
	16x; 31216220→		420 0086 10
	12 mm		
	16x; →31216219		420 0218 10
	12 mm		
	16x; 31216220→		422 0144 10
	1x;		SKIT 559 0045 10
	1x; BS		SKIT 559 0051 10



FAG	; → 1.850 kg		Set 713 6680 10
	96 mm		
	; 1.850 kg →		Set 713 6680 20
	96 mm		
	; ; BM 906.132 906.134 906.136		Set 713 6681 10
	right		818 0336 10
	left		818 0335 10
	;		818 0447 10
	↔		825 0327 10
	↔		840 0373 10
			840 1111 10

216 (906.613, 906.713)
 M 271.951; (115kW)

09.08-





















































































































LUK	SAC		624 3247 33
			415 0293 10
			411 0154 10
			532 0401 30
			532 0648 10
	; →03.09; →31216219		534 0081 30
	; 03.09→; 31216220→		534 0370 10
	№# F-232001.XX		535 0042 10
	№# F-557311.XX		535 0165 10
	16x; 31216220→		420 0086 10
	12 mm		
	16x; →31216219		420 0218 10
	12 mm		
	16x; 31216220→		422 0144 10
	1x;		SKIT 559 0045 10
	1x; BS		SKIT 559 0051 10
FAG	right		821 0700 10



			<p>SCHAEFFLER</p>	
--	---	--	--------------------------	--

MERCEDES-BENZ

Sprinter (906) 3-t - 5-t				
<p>216 (906.613, 906.713) M 271.951; (115kW)</p>	<p>09.08-</p>	<p>FAG</p>	<p> left  → 1.850 kg  96 mm  → 1.850 kg  96 mm  BM 906.132 906.134 906.136  right  left  →  ← </p>	<p> 821 0699 10  713 6680 10  713 6680 20  713 6681 10  818 0336 10  818 0335 10  818 0447 10  825 0327 10  840 0373 10  840 1111 10  600 0291 00</p>
<p>216 CDI (906.111, 906.113, 906.211, 906.213, 906.611, 906.613) OM 651.955; OM 651.957; (120kW)</p>	<p>03.09-</p>	<p>LUK</p>	<p>incl.  SAC  START/STOP A/C  A/C       START/STOP  START/STOP # F-233197.XX F-559320.XX  START/STOP  →08.10;  →S 495102; START/STOP  16x  12 mm 16x </p>	<p> 624 3408 33  415 0660 10  411 0150 10  529 0361 10  532 0108 10  532 0570 10  532 0608 10  532 0671 10  532 0672 10  534 0337 10  534 0444 10  535 0050 10  FB 6PK2215  538 0221 10  420 0225 10  422 0099 10  821 0700 10  821 0699 10  713 6680 10  713 6680 20  713 6681 10  818 0336 10  818 0335 10  818 0447 10  825 0327 10  840 0373 10  840 1111 10  600 0291 00  624 3408 33  415 0660 10  411 0150 10  529 0361 10  532 0108 10  532 0570 10  532 0608 10  532 0671 10  532 0672 10  534 0337 10  534 0444 10  535 0050 10  FB 6PK2215  420 0225 10  422 0099 10  713 6680 10</p>
<p>216 CDI (906.711, 906.713) OM 651.955; OM 651.957; (120kW)</p>	<p>06.06-</p>	<p>LUK</p>	<p>incl.  SAC  START/STOP A/C  A/C       START/STOP  START/STOP # F-233197.XX F-559320.XX  START/STOP  START/STOP 16x  12 mm 16x </p>	<p> 624 3408 33  415 0660 10  411 0150 10  529 0361 10  532 0108 10  532 0570 10  532 0608 10  532 0671 10  532 0672 10  534 0337 10  534 0444 10  535 0050 10  FB 6PK2215  420 0225 10  422 0099 10  713 6680 10</p>
		<p>FAG</p>	<p> → 1.850 kg  96 mm</p>	<p> 713 6680 10</p>



			SCHAEFFLER
--	--	--	-------------------





















































































































MERCEDES-BENZ

Sprinter (906) 3-t - 5-t													
216 CDI (906.711, 906.713) OM 651.955; OM 651.957; (120kW)	06.06-	FAG	; 1.850 kg → 96 mm ; ; ; BM 906.132 906.134 906.136 ; ↔ ↔ 	Set 713 6680 20 Set 713 6681 10 818 0447 10 825 0327 10 840 0373 10 840 1111 10									
			218 CDI (906.111, 906.113, 906.211, 906.213) OM 642.896; OM 642.992; OM 642.993; (135kW)	06.06-12.09	LUK	; NSG 370; ID 711.651 ; NSG 400; ID 711.660; Z 515.401/08 Z 515.401/09 ; NSG 400; ID 711.660; Z 515.401/06 ; TSG 360; ID 711.680 SAC	GearBOX 462 0152 10 GearBOX 462 0238 10 GearBOX 462 0313 10 GearBOX 462 0332 10 626 3026 33 415 0304 10 411 0147 10 532 0234 10 532 0566 10 534 0183 10 534 0257 10 534 0506 10 535 0050 10 535 0140 10 HYDP; A/C ; A/C; # OE 0019933696 ; PTO; A/C ; A/C 538 0234 10 420 0086 10 24x 12 mm 24x 1x 1x 1x 1x 1x 1x 1x 1x 422 0056 10 558 0039 10 559 0049 10 559 0050 10 559 0087 10 559 0088 10 558 0040 10						
						218 CDI (906.611, 906.613) OM 642.896; OM 642.992; (135kW)	06.06-12.09	FAG	right left ; → 1.850 kg 96 mm ; 1.850 kg → 96 mm ; ; ; BM 906.132 906.134 906.136 right left ; ↔ ↔ 	821 0700 10 821 0699 10 Set 713 6680 10 Set 713 6680 20 Set 713 6681 10 818 0336 10 818 0335 10 818 0447 10 825 0327 10 840 0373 10 840 1111 10			
									218 CDI (906.611, 906.613) OM 642.896; OM 642.992; (135kW)	06.06-12.09	LUK	; NSG 400; ID 711.660; Z 515.401/08 Z 515.401/09 ; NSG400; ID 711.660; Z 515.401/06 ; TSG 360; ID 711.680 SAC	GearBOX 462 0238 10 GearBOX 462 0313 10 GearBOX 462 0332 10 626 3026 33 415 0304 10 411 0147 10 532 0234 10 532 0566 10 534 0183 10 534 0257 10 534 0506 10 535 0050 10 535 0140 10 HYDP; A/C ; A/C; # OE 0019933696 ; PTO; A/C ; A/C 538 0234 10



			SCHAEFFLER
--	---	--	-------------------

MERCEDES-BENZ

Sprinter (906) 3-t - 5-t			
218 CDI (906.611, 906.613) OM 642.896; OM 642.992; (135kW)	06.06-12.09	 FAG	24x  12 mm  420 0086 10
			24x  422 0056 10
			1x  558 0039 10
			1x  559 0049 10
			1x  559 0050 10
			1x  559 0087 10
			1x  559 0088 10
			1x  558 0040 10
			right  821 0700 10
			left  821 0699 10
			 ;  → 1.850 kg  96 mm  ;  1.850 kg →  96 mm  ;  ;  BM 906.132 906.134 906.136  713 6680 10
			right  818 0336 10
			left  818 0335 10
			 ;   818 0447 10
			 ↔  825 0327 10
			 ↔  840 0373 10
			  840 1111 10
219 CDI / BlueTEC (906.111, 906.113, 906.211, 906.213) OM 642.896; OM 642.992; (140kW)	03.09-05.16	 LUK	SAC  626 3026 33  OM 642.992  415 0304 10  411 0147 10
			 START/STOP  529 0050 10
			2x  532 0234 10
			A/C  532 0566 10
			 ;  OM 642.992  534 0183 10
			A/C  534 0257 10
			 ; START/STOP ;  OM 642.896  534 0506 10
			 # F-239808.XX  535 0140 10
			HYDP; A/C  FB 6PK1413
			 ; A/C ; # OE 0019933696  FB 7PK1973
			 ; PTO ; A/C  FB 7PK2035
			 ; A/C  FB 7PK2045
			 538 0234 10
			24x  12 mm  420 0086 10
			24x  422 0056 10
			1x;  642.896; →04.15;  →41711428  558 0039 10
			1x;  642.992; →09.14;  →41633498  559 0087 10
1x;  642.896; →04.15;  →41711428  559 0088 10			
1x;  642.992; →09.14;  →41633498  558 0040 10			
1x  558 0040 10			
right  713 6680 10			
 ;  → 1.850 kg  96 mm  ;  1.850 kg →  96 mm  ;  ;  BM 906.132 906.134 906.136  713 6681 10			
right  818 0336 10			
left  818 0335 10			
 ;   818 0447 10			
 ↔  825 0327 10			
 ↔  840 0373 10			
  840 1111 10			
219 CDI / BlueTEC (906.611, 906.613) OM 642.896; OM 642.992; (140kW)	03.09-	 LUK	SAC  626 3026 33  OM 642.992  415 0304 10  411 0147 10
			 START/STOP  529 0050 10
			2x  532 0234 10
			A/C  532 0566 10
			 ;  OM 642.992  534 0183 10
			A/C  534 0257 10
			 ; START/STOP ;  OM 642.896  534 0506 10
			 # F-239808.XX  535 0140 10
			HYDP; A/C  FB 6PK1413



			SCHAEFFLER
--	--	--	-------------------



































MERCEDES-BENZ

Sprinter (906) 3-t - 5-t

219 CDI / BlueTEC (906.611, 906.613)
 OM 642.896; OM 642.992;
 (140kW)

03.09-

















































	1; A/C; # OE 0019933696		FB 7PK1973
	1; PTO; A/C		FB 7PK2035
	1; A/C		FB 7PK2045
			538 0234 10
	24x		420 0086 10
	 12 mm		
	24x		422 0056 10
	1x; OM 642.896; →04.15; →41711428		558 0039 10
	1x; OM 642.992; →09.14; →41633498		
	1x; OM 642.896; →04.15; →41711428		559 0087 10
	1x; OM 642.992; →09.14; →41633498		
	1x; OM 642.896; →04.15; →41711428		559 0088 10
	1x; OM 642.992; →09.14; →41633498		
	1x		558 0040 10
FAG	right		821 0700 10
	left		821 0699 10
	 ; → 1.850 kg		713 6680 10
	 96 mm		
	 ; → 1.850 kg →		713 6680 20
	 96 mm		
	 ; →;  ;  ;  BM 906.132 906.134 906.136		713 6681 10
	right		818 0336 10
	left		818 0335 10
			818 0447 10
	↔		825 0327 10
	↔		840 0373 10
			840 1111 10

224 (906.113, 906.213)
 M 272.979; (190kW)

06.06-12.13









	G6; NSG 370; ID 711.651	GearBOX	462 0152 10
	G6; NSG 400; ID 711.660;	GearBOX	462 0238 10
	 Z 515.401/08 Z 515.401/09		
	G6; NSG 400; ID 711.660;  Z 515.401/06	GearBOX	462 0313 10
	G6; TSG 360; ID 711.680	GearBOX	462 0332 10
INA	03.07→; 30621934→; A/C		529 0034 10
	 ; A/C		532 0108 10
	 ; →03.07; →30621933		532 0160 10
			532 0539 10
	 ; A/C		532 0667 10
	 ; 03.07→; 30621934→		532 0866 10
	 ; MANU		533 0100 10
			534 0067 10
			FB 6PK2403
			538 0244 10
	24x		420 0086 10
	 12 mm		
	24x		422 0055 10
	1x		553 0147 10
	1x		558 0041 10
	1x		559 0093 10
FAG	right		821 0700 10
	left		821 0699 10
	 ; → 1.850 kg		713 6680 10
	 96 mm		
	 ; → 1.850 kg →		713 6680 20
	 96 mm		
	 ; →;  ;  ;  BM 906.132 906.134 906.136		713 6681 10
	right		818 0336 10
	left		818 0335 10
			818 0447 10
	↔		825 0327 10
	↔		840 0373 10
			840 1111 10

224 (906.613)
 M 272.979; (190kW)

06.06-













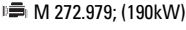



















































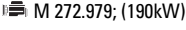

































































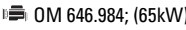







	G6; NSG 370; ID 711.651	GearBOX	462 0152 10
	G6; NSG 400; ID 711.660;	GearBOX	462 0238 10
	 Z 515.401/08 Z 515.401/09		
	G6; NSG 400; ID 711.660;  Z 515.401/06	GearBOX	462 0313 10
	G6; TSG 360; ID 711.680	GearBOX	462 0332 10
INA	03.07→; 30621934→; A/C		529 0034 10
	 ; A/C		532 0108 10
	 ; →03.07; →30621933		532 0160 10



			SCHAEFFLER
--	---	--	-------------------

MERCEDES-BENZ

Sprinter (906) 3-t - 5-t

<p>224 (906.613)  M 272.979; (190kW)</p>	<p>06.06-</p>	<p></p>	<p>  A/C  ; 03.07 → ;  30621934 →  ;    24x;  M272.979  12 mm 24x;  M272.979 1x 1x 1x FAG  right  left  ;  → 1.850 kg  96 mm  ;  1.850 kg →  96 mm  ;  BM 906.132 906.134 906.136  right  left  ;   ↔  ↔ </p>	<p> 532 0539 10  532 0667 10  532 0866 10  533 0100 10  534 0067 10  FB 6PK2403  538 0244 10  420 0086 10  422 0055 10  OILP 553 0147 10  KIT 558 0041 10  KIT 559 0093 10  821 0700 10  Set 821 0699 10  Set 713 6680 10  Set 713 6680 20  Set 713 6681 10  818 0336 10  818 0335 10  818 0447 10  825 0327 10  840 0373 10  840 1111 10</p>
<p>224 (906.713)  M 272.979; (190kW)</p>	<p>06.06-12.13</p>	<p></p> <p></p>	<p>G6 ;  NSG 370 ;  ID 711.651 G6 ;  NSG 400 ;  ID 711.660 ;  Z 515.401/08 Z 515.401/09 G6 ;  NSG400 ;  ID 711.660 ;  Z 515.401/06 03.07 → ;  30621934 → ; A/C  A/C  ; →03.07 ;  →30621933  A/C  ; 03.07 → ;  30621934 →  ;    24x  12 mm 24x 1x 1x 1x FAG  right  left  ;  → 1.850 kg  96 mm  ;  1.850 kg →  96 mm  ;  BM 906.132 906.134 906.136  right  left  ;   ↔  ↔ </p>	<p>GearBOX 462 0152 10 GearBOX 462 0238 10 GearBOX 462 0313 10  529 0034 10  532 0108 10  532 0160 10  532 0539 10  532 0667 10  532 0866 10  533 0100 10  534 0067 10  FB 6PK2403  538 0244 10  420 0086 10  422 0055 10  OILP 553 0147 10  KIT 558 0041 10  KIT 559 0093 10  821 0700 10  821 0699 10  Set 713 6680 10  Set 713 6680 20  Set 713 6681 10  818 0336 10  818 0335 10  818 0447 10  825 0327 10  840 0373 10  840 1111 10</p>
<p>309 CDI (906.131, 906.133, 906.135, 906.231, 906.233, ...)  OM 646.984; (65kW)</p>	<p>06.06-12.09</p>	<p></p>	<p>G6 ;  NSG 400 ;  ID 711.660 ;  Z 515.401/08 Z 515.401/09 G6 ;  NSG400 ;  ID 711.660 ;  Z 515.401/06 G6 ;  TSG 360 ;  ID 711.680 incl.  ; incl.  ; SAC SAC  </p>	<p>GearBOX 462 0238 10 GearBOX 462 0313 10 GearBOX 462 0332 10  600 0255 00  624 3247 33  415 0309 10  411 0147 10</p>



			SCHAEFFLER
--	---	--	-------------------

MERCEDES-BENZ

Sprinter (906) 3-t - 5-t

309 CDI (906.131, 906.133, 906.135, 906.231, 906.233, ...)
 OM 646.984; (65kW)

06.06-12.09



	A/C		529 0115 10
	A/C ; A/C		532 0391 20
	2x		532 0160 10
	OPTION		533 0017 10
			534 0481 10
	F-233197.XX F-559320.XX		535 0050 10
	F-552901.XX		535 0168 10
	PTO		544 0116 10
	PTO		FB 6PK2260
	A/C		FB 6PK2285
	PTO		FB 6PK2285
	A/C		538 0224 10
	16x		420 0170 10
	33 mm		
			428 0092 10
			428 0184 10
	1x		553 0147 10
	1x		559 0039 10
	KIT		821 0700 10
	right		821 0699 10
	left		821 0699 10
	→ 1.850 kg		713 6680 10
	96 mm		713 6680 20
	→ 1.850 kg		713 6680 20
	96 mm		713 6681 10
	BM 906.132 906.134 906.136		713 6681 10
	right		818 0336 10
	left		818 0335 10
	BM		818 0447 10
	↔		825 0327 10
	↔		840 0373 10
	right		840 1111 10

FAG

309 CDI (906.631, 906.633, 906.635, 906.637)
 OM 646.984; (65kW)

06.06-12.09



	G6 ; NSG 370 ; ID 711.651		GearBOX 462 0152 10
	G6 ; NSG 400 ; ID 711.660;		GearBOX 462 0238 10
	Z 515.401/08 Z 515.401/09		
	G6 ; NSG400 ; ID 711.660; Z 515.401/06		GearBOX 462 0313 10
	G6 ; TSG 360 ; ID 711.680		GearBOX 462 0332 10
	incl. ; incl. ; SAC		600 0255 00
	SAC		624 3247 33
			415 0309 10
			411 0147 10



	A/C		529 0115 10
	A/C ; A/C		532 0391 20
	2x		532 0160 10
	OPTION		533 0017 10
			534 0481 10
	F-233197.XX F-559320.XX		535 0050 10
	F-552901.XX		535 0168 10
	PTO		544 0116 10
	PTO		FB 6PK2260
	A/C		FB 6PK2285
	PTO		FB 6PK2285
	A/C		538 0224 10
	16x		420 0170 10
	33 mm		
			428 0092 10
			428 0184 10
	1x		553 0147 10
	1x		559 0039 10
	KIT		821 0700 10
	right		821 0699 10
	left		821 0699 10
	→ 1.850 kg		713 6680 10
	96 mm		713 6680 20
	→ 1.850 kg		713 6680 20
	96 mm		713 6681 10
	BM 906.132 906.134 906.136		713 6681 10
	right		818 0336 10

















































































































































FAG



			SCHAEFFLER
--	---	--	-------------------

MERCEDES-BENZ

Sprinter (906) 3-t - 5-t











































































































<p>309 CDI (906.631, 906.633, 906.635, 906.637)  OM 646.984; (65kW)</p>	<p>06.06-12.09</p>	<p>FAG</p>	<p> left</p>	 818 0335 10
			 	 818 0447 10
			 	 825 0327 10
			 	 840 0373 10
				 840 1111 10
				 600 0291 00
<p>310 CDI (906.131, 906.133, 906.135, 906.231, 906.233, ..., 906.631, 906.633, 906.635, 906.637, 906.731, 906.733, 906.735)  OM 651.955; OM 651.956; (70kW)</p>	<p>03.09-</p>	<p>LUK</p>	<p>incl.  </p>	 624 3408 33
			<p>SAC</p>	 415 0660 10
			  ; START/STOP A/C	 411 0150 10
			 ; A/C	 529 0361 10
			 ; 	 532 0108 10
			 ; 	 532 0570 10
			 ; 	 532 0608 10
				 532 0671 10
				 532 0672 10
			 ; START/STOP	 534 0337 10
			 ; START/STOP	 534 0444 10
			 # F-233197.XX F-559320.XX	 535 0050 10
			 # F-552901.XX	 535 0168 10
			 ; START/STOP	 FB 6PK2215
			 ;  →S 495102; START/STOP	 538 0221 10
			<p>16x  12 mm</p>	 420 0225 10
			<p>16x</p>	 422 0099 10
			<p>FAG</p>	<p> right</p>
			<p> left</p>	 821 0699 10
			<p> ;  → 1.850 kg</p>	  713 6680 10
			<p> 96 mm</p>	  713 6680 20
			<p> ;  1.850 kg →</p>	  713 6681 10
			<p> 96 mm</p>	  713 6681 10
			<p> ;  BM 906.132 906.134 906.136</p>	  713 6681 10
			<p> right</p>	 818 0336 10
			<p> left</p>	 818 0335 10
			<p> ; </p>	 818 0447 10
			<p> </p>	 825 0327 10
			<p> </p>	 840 0373 10
			<p></p>	 840 1111 10
<p>311 CDI (906.131, 906.133, 906.135, 906.231, 906.233, ...)  OM 646.985; (80kW)</p>	<p>06.06-12.09</p>	<p>LUK</p>	<p>G6 ;  NSG 370 ;  ID 711.651</p>	<p>GearBOX 462 0152 10</p>
			<p>G6 ;  NSG 400 ;  ID 711.660;</p>	<p>GearBOX 462 0238 10</p>
			<p>  Z 515.401/08 Z 515.401/09</p>	<p>GearBOX 462 0313 10</p>
			<p>G6 ;  NSG400 ;  ID 711.660;   Z 515.401/06</p>	<p>GearBOX 462 0332 10</p>
			<p>G6 ;  TSG 360 ;  ID 711.680</p>	<p>GearBOX 600 0255 00</p>
			<p>incl.   ; SAC</p>	 624 3247 33
			<p>SAC</p>	 415 0309 10
			<p>  ; A/C</p>	 411 0147 10
			<p> ; A/C</p>	 529 0115 10
			<p></p>	 532 0391 20
			<p> ; 2x</p>	 532 0108 10
			<p> ; OPTION</p>	 532 0160 10
			<p></p>	 533 0017 10
			<p> # F-233197.XX F-559320.XX</p>	 534 0481 10
			<p> # F-552901.XX</p>	 535 0050 10
			<p></p>	 535 0168 10
			<p></p>	 544 0116 10
			<p> ; A/C</p>	 FB 6PK2260
			<p> ; A/C</p>	 FB 6PK2285
			<p>16x  33 mm</p>	 538 0224 10
			<p></p>	 420 0170 10
			<p></p>	 428 0092 10
			<p>1x</p>	 428 0184 10
			<p>1x</p>	 OILP 553 0147 10
			<p>1x</p>	 KIT 559 0039 10
			<p>FAG</p>	<p> right</p>
			<p> left</p>	 821 0699 10



			SCHAEFFLER
--	---	--	-------------------

MERCEDES-BENZ

Sprinter (906) 3-t - 5-t

































































































































311 CDI (906.131, 906.133, 906.135, 906.231, 906.233, ...) OM 646.985; (80kW)	06.06-12.09	FAG	 ;  → 1.850 kg	 Set	713 6680 10
			 96 mm	 Set	713 6680 20
			 ;  1.850 kg →	 Set	713 6681 10
			 96 mm		
			 ;  ;  BM 906.132 906.134 906.136		
			 right		818 0336 10
			 left		818 0335 10
					818 0447 10
			 ↔		825 0327 10
			 ↔		840 0373 10
		840 1111 10			
311 CDI (906.131, 906.133, 906.135, 906.231, 906.233, ..., 906.631, 906.633, 906.635, 906.637) OM 651.955; (84kW)	05.16-	LUK	G6 ;  NSG 370 ;  ID 711.651	GearBOX	462 0152 10
			incl. 		600 0291 00
			SAC		624 3408 33
					415 0660 10
					411 0150 10
			 # F-233197.XX F-559320.XX		535 0050 10
			 # F-552901.XX		535 0168 10
			 ; START/STOP		FB 6PK2215
			16x		420 0225 10
			 12 mm		
311 CDI (906.631, 906.633, 906.635, 906.637) OM 646.985; (80kW)	06.06-12.09	LUK	G6 ;  NSG 370 ;  ID 711.651	GearBOX	462 0152 10
			G6 ;  NSG 400 ;  ID 711.660 ;	GearBOX	462 0238 10
			 Z 515.401/08 Z 515.401/09		
			G6 ;  NSG400 ;  ID 711.660 ;  Z 515.401/06	GearBOX	462 0313 10
			G6 ;  TSG 360 ;  ID 711.680	GearBOX	462 0332 10
			incl.  ; incl.  ; SAC		600 0255 00
			SAC		624 3247 33
					415 0309 10
					411 0147 10
			 ; A/C		529 0115 10
A/C ; 		532 0391 20			
		532 0108 10			
 ; 2x		532 0160 10			
 ; OPTION		533 0017 10			
		534 0481 10			
 # F-233197.XX F-559320.XX		535 0050 10			
 # F-552901.XX		535 0168 10			
		544 0116 10			
 ; A/C		FB 6PK2260			
 ; A/C		FB 6PK2285			
		538 0224 10			
16x		420 0170 10			
 33 mm					
		428 0092 10			
		428 0184 10			
1x		553 0147 10			
1x		559 0039 10			
FAG		 right		821 0700 10	
		 left		821 0699 10	
		 ;  → 1.850 kg	 Set	713 6680 10	
		 96 mm			
		 ;  1.850 kg →	 Set	713 6680 20	
		 96 mm			
 ;  ;  BM 906.132 906.134 906.136	 Set	713 6681 10			



			SCHAEFFLER
--	---	--	-------------------

MERCEDES-BENZ

Sprinter (906) 3-t - 5-t





















































































































311 CDI (906.631, 906.633, 906.635, 906.637) OM 646.985; (80kW)	06.06-12.09	FAG	 right		818 0336 10
			 left		818 0335 10
			 ; 		818 0447 10
			 ↔		825 0327 10
			 ↔		840 0373 10
					840 1111 10
311 CDI (906.731, 906.733, 906.735) OM 646.985; (80kW)	06.06-12.09	LUK	G6 ;  NSG 370 ;  ID 711.651	GearBOX	462 0152 10
			G6 ;  NSG 400 ;  ID 711.660 ;  Z 515.401/08 Z 515.401/09	GearBOX	462 0238 10
			G6 ;  NSG 400 ;  ID 711.660 ;  Z 515.401/06	GearBOX	462 0313 10
			incl.  ; incl.  ; SAC		600 0255 00
			SAC		624 3247 33
					415 0309 10
					411 0147 10
			 ; A/C		529 0115 10
			A/C ; 		532 0391 20
					532 0108 10
			 ; 2x		532 0160 10
			 ; OPTION		533 0017 10
					534 0481 10
			 # F-233197.XX F-559320.XX		535 0050 10
			 # F-552901.XX		535 0168 10
					544 0116 10
			 ; A/C		FB 6PK2260
			 ; A/C		FB 6PK2285
					538 0224 10
			16x		420 0170 10
			 33 mm		
					428 0092 10
					428 0184 10
			1x		OILP 553 0147 10
			1x		KIT 559 0039 10
		FAG	 right		821 0700 10
			 left		821 0699 10
			 ;  → 1.850 kg		Set 713 6680 10
			 96 mm		
			 ;  1.850 kg →		Set 713 6680 20
			 96 mm		
			 ;  ;  ;  BM 906.132 906.134 906.136		Set 713 6681 10
			 right		818 0336 10
			 left		818 0335 10
			 ; 		818 0447 10
			 ↔		825 0327 10
			 ↔		840 0373 10
					840 1111 10
311 CDI (906.731, 906.733, 906.735) OM 651.955; (84kW)	05.16-	LUK	G6 ;  NSG 370 ;  ID 711.651	GearBOX	462 0152 10
			incl.  ; SAC		600 0291 00
			SAC		624 3408 33
					415 0660 10
					411 0150 10
			 # F-233197.XX F-559320.XX		535 0050 10
			 # F-552901.XX		535 0168 10
			 ; START/STOP		FB 6PK2215
			16x		420 0225 10
			 12 mm		
			16x		422 0099 10
		FAG	 ;  → 1.850 kg		Set 713 6680 10
			 96 mm		
			 ;  1.850 kg →		Set 713 6680 20
			 96 mm		
			 ;  ;  ;  BM 906.132 906.134 906.136		Set 713 6681 10
			 right		818 0336 10
			 left		818 0335 10
			 ; 		818 0447 10
			 ↔		840 0373 10
					840 1111 10



			SCHAEFFLER
--	--	--	-------------------

MERCEDES-BENZ









































































































































Sprinter (906) 3-t - 5-t

<p>311 CDI 4x4 (906.131, 906.133, 906.135, 906.231, 906.233.., 906.631, 906.633, 906.635, 906.637) OM 646.985; (80kW)</p>	02.08-12.09		<p>G6 ; NSG 400 ; ID 711.660; Z 515.401/08 Z 515.401/09</p>	GearBOX	462 0238 10
			<p>G6 ; NSG 400 ; ID 711.660; Z 515.401/06</p>	GearBOX	462 0313 10
			<p>G6 ; TSG 360 ; ID 711.680</p>	GearBOX	462 0332 10
			<p>incl. ○; incl. ■■■■■; SAC</p>		600 0255 00
			SAC		624 3247 33
					415 0309 10
					411 0147 10
			A/C ; A/C		532 0391 20
					532 0108 10
					532 0160 10
					533 0017 10
					534 0481 10
					535 0050 10
					535 0168 10
					544 0116 10
					FB 6PK2260
					538 0224 10
					420 0170 10
					428 0092 10
					428 0184 10
					553 0147 10
			1x		559 0039 10
			1x		713 6680 30
					713 6681 10
					825 0327 10
					840 0373 10
					840 1111 10
					462 0238 10
					462 0313 10
					600 0255 00
					624 3247 33
<p>311 CDI 4x4 (906.731, 906.733, 906.735) OM 646.985; (80kW)</p>	02.08-12.09		<p>G6 ; NSG 400 ; ID 711.660; Z 515.401/08 Z 515.401/09</p>	GearBOX	462 0238 10
			<p>G6 ; NSG 400 ; ID 711.660; Z 515.401/06</p>	GearBOX	462 0313 10
			<p>incl. ○; incl. ■■■■■; SAC</p>		600 0255 00
			SAC		624 3247 33
					415 0309 10
					411 0147 10
			A/C ; A/C		532 0391 20
					532 0108 10
					532 0160 10
					533 0017 10
					534 0481 10
					535 0050 10
					535 0168 10
					544 0116 10
					FB 6PK2260
					538 0224 10
					420 0170 10
					428 0092 10
					428 0184 10
					553 0147 10
			1x		559 0039 10
			1x		713 6680 30
					713 6681 10
					825 0327 10
					840 0373 10
					840 1111 10
					462 0238 10
					462 0313 10
					600 0255 00
					624 3247 33
<p>313 CDI (906.131, 906.133, 906.135, 906.231, 906.233, ..) OM 651.955; OM 651.956; (95kW)</p>	06.06-05.16		<p>incl. ○</p>		600 0291 00
			SAC		624 3408 33
					415 0660 10
					411 0150 10
					529 0361 10
					532 0108 10
					532 0570 10



			SCHAEFFLER
--	---	--	-------------------

MERCEDES-BENZ

Sprinter (906) 3-t - 5-t							
313 CDI (906.131, 906.133, 906.135, 906.231, 906.233, ..) OM 651.955; OM 651.956; (95kW)	06.06-05.16		 ; 	 532 0608 10			
				 532 0671 10			
				 532 0672 10			
			 ; START/STOP	 534 0337 10			
			 ; START/STOP	 534 0444 10			
			 # F-233197.XX F-559320.XX	 535 0050 10			
			 ; START/STOP	 FB 6PK2215			
			 ; →08.10;  →S 495102; START/STOP				
			16x  12 mm	 420 0225 10			
			16x	 422 0099 10			
			 ;  → 1.850 kg  96 mm	 Set 713 6680 10			
			 ;  1.850 kg →  96 mm	 Set 713 6680 20			
			 ;  ;  BM 906.132 906.134 906.136	 Set 713 6681 10			
			 ; 	 818 0447 10			
			 ↔	 825 0327 10			
 ↔	 840 0373 10						
	 840 1111 10						
313 CDI (906.131, 906.133, 906.135, 906.231, 906.233, ..) OM 646.986; (95kW)	06.06-05.16		 SA 522609 08 incl.  ; incl.  ; SAC	 600 0255 00			
			 SA 522609 11 incl.  ; incl.  ; SAC	 600 0260 00			
			SAC	 624 3247 33			
				 415 0309 10			
			 SA 522609 08	 411 0147 10			
			 SA 522609 11	 411 0160 10			
						 ; A/C	 529 0115 10
						A/C ; 	 532 0391 20
						 ; 2x	 532 0160 10
						 ; OPTION	 533 0017 10
							 534 0481 10
						 # F-233197.XX F-559320.XX	 535 0050 10
						 # F-552901.XX	 535 0168 10
							 544 0116 10
						 ; A/C	 FB 6PK2260
 ; A/C	 FB 6PK2285						
	 538 0224 10						
16x  33 mm	 420 0170 10						
	 428 0092 10						
	 428 0184 10						
						 right	 821 0700 10
			 left	 821 0699 10			
			 ;  → 1.850 kg  96 mm	 Set 713 6680 10			
			 ;  1.850 kg →  96 mm	 Set 713 6680 20			
			 ;  ;  BM 906.132 906.134 906.136	 Set 713 6681 10			
			 right	 818 0336 10			
			 left	 818 0335 10			
			 ; 	 818 0447 10			
			 ↔	 825 0327 10			
			 ↔	 840 0373 10			
				 840 1111 10			
			313 CDI (906.631, 906.633, 906.635, 906.637) OM 646.986; (95kW)	06.06-		 SA 522609 08 SA 522609 09 incl.  ; incl.  ; SAC	 600 0255 00
						 SA 522609 11 incl.  ; incl.  ; SAC	 600 0260 00
						SAC	 624 3247 33
							 415 0309 10
 SA 522609 08 SA 522609 09	 411 0147 10						
 SA 522609 11	 411 0160 10						
						 ; A/C	 529 0115 10
						A/C ; 	 532 0391 20
						 ; 2x	 532 0160 10



			SCHAEFFLER
--	--	--	-------------------

MERCEDES-BENZ























































Sprinter (906) 3-t - 5-t

313 CDI (906.631, 906.633, 906.635, 906.637)

OM 646.986; (95kW)

06.06-

























































 ; OPTION		533 0017 10
		534 0481 10
 # F-233197.XX F-559320.XX		535 0050 10
 # F-552901.XX		535 0168 10
 ;  OM 646.986;  A/C		544 0116 10
 ;  A/C ;  OM 646.986		FB 6PK2260
		FB 6PK2285
16x		538 0224 10
 33 mm		420 0170 10
		428 0092 10
		428 0184 10
1x		OILP 553 0147 10
1x		SKIT 559 0039 10
FAG  right		821 0700 10
 left		821 0699 10
 ;  → 1.850 kg		Set 713 6680 10
 96 mm		
 ;  1.850 kg →		Set 713 6680 20
 96 mm		
 ;  BM 906.132 906.134 906.136		Set 713 6681 10
 right		818 0336 10
 left		818 0335 10
 ; 		818 0447 10
 ↔		825 0327 10
 ↔		840 0373 10
		840 1111 10

313 CDI (906.631, 906.633, 906.635, 906.637)

OM 651.940; OM 651.955; (95kW)

05.09-





















		600 0291 00
incl. 		624 3408 33
SAC		415 0660 10
		411 0150 10
 ; START/STOP A/C		529 0361 10
 ; A/C		532 0108 10
 ; 		532 0570 10
 ; 		532 0608 10
		532 0671 10
		532 0672 10
 ; START/STOP		534 0337 10
 ; START/STOP		534 0444 10
 # F-233197.XX F-559320.XX		535 0050 10
 # F-552901.XX		535 0168 10
 ; START/STOP		FB 6PK2215
 ; →08.10;  →S 495102; START/STOP		538 0221 10
16x		420 0225 10
 12 mm		
16x		422 0099 10
FAG  ;  → 1.850 kg		Set 713 6680 10
 96 mm		
 ;  1.850 kg →		Set 713 6680 20
 96 mm		
 right		818 0336 10
 left		818 0335 10
 ; 		818 0447 10
 ↔		825 0327 10
 ↔		840 0373 10
		840 1111 10

313 CDI (906.731, 906.733, 906.735)

OM 651.955; (95kW)

08.11-05.16































































































































		600 0291 00
incl. 		624 3408 33
SAC		415 0660 10
		411 0150 10
 ; START/STOP A/C		529 0361 10
 ; A/C		532 0108 10
 ; 		532 0570 10
 ; 		532 0608 10
		532 0671 10



			SCHAEFFLER
--	---	--	-------------------

MERCEDES-BENZ

Sprinter (906) 3-t - 5-t

313 CDI (906.731, 906.733, 906.735) OM 651.955; (95kW)	08.11-05.16		 532 0672 10		532 0672 10	
			 ; START/STOP		534 0337 10	
			 ; START/STOP		534 0444 10	
			 # F-233197.XX F-559320.XX		535 0050 10	
			 # F-552901.XX		535 0168 10	
			 ; START/STOP		FB 6PK2215	
					538 0221 10	
			16x		420 0225 10	
			 12 mm			
			16x		422 0099 10	
		FAG	 ;  → 1.850 kg	 Set	713 6680 10	
			 96 mm			
			 ;  1.850 kg →	 Set	713 6680 20	
			 96 mm			
			 right		818 0336 10	
			 left		818 0335 10	
			 ; 		818 0447 10	
			 ↔		825 0327 10	
			 ↔		840 0373 10	
					840 1111 10	
313 CDI 4x4 (906.131, 906.133, 906.135, 906.231, 906.233.., 906.631, 906.633, 906.635, 906.637) OM 651.955; (95kW)	06.06-		 incl. 		600 0291 00	
			SAC		624 3408 33	
					415 0660 10	
					411 0150 10	
				 ; START/STOP A/C		529 0361 10
				 ; A/C		532 0108 10
						532 0570 10
				 ; 		532 0608 10
						532 0671 10
						532 0672 10
		 ; START/STOP			534 0337 10	
		 ; START/STOP			534 0444 10	
		 # F-233197.XX F-559320.XX			535 0050 10	
		 # F-552901.XX			535 0168 10	
		 ; START/STOP		FB 6PK2215		
		 ; →08.10;  →S 495102; START/STOP		538 0221 10		
		16x		420 0225 10		
		 12 mm				
		16x		422 0099 10		
		FAG	  96 mm	 Set	713 6680 30	
 ;  BM 906.132 906.134 906.136	 Set		713 6681 10			
 ↔			825 0327 10			
 ↔			840 0373 10			
			840 1111 10			
			600 0291 00			
			624 3408 33			
			415 0660 10			
			411 0150 10			
	 ; START/STOP A/C			529 0361 10		
	 ; A/C		532 0108 10			
			532 0570 10			
	 ; 		532 0608 10			
			532 0671 10			
			532 0672 10			
	 ; START/STOP		534 0337 10			
	 ; START/STOP		534 0444 10			
	 # F-233197.XX F-559320.XX		535 0050 10			
	 # F-552901.XX		535 0168 10			
 ; START/STOP		FB 6PK2215				
		538 0221 10				
16x		420 0225 10				
 12 mm						
16x		422 0099 10				



			SCHAEFFLER
--	--	--	-------------------

MERCEDES-BENZ

Sprinter (906) 3-t - 5-t

























































































































































313 CDI 4x4 (906.731, 906.733, 906.735) OM 651.955; (95kW)	08.11-05.16	FAG 	96 mm		713 6680 30
			; ; ; BM 906.132 906.134 906.136		713 6681 10
			↔		825 0327 10
			↔		840 0373 10
					840 1111 10
					600 0291 00
					624 3408 33
					415 0660 10
					411 0150 10
			# F-233197.XX F-559320.XX # F-552901.XX ; START/STOP		535 0050 10
			16x 12 mm		535 0168 10
			16x 12 mm		FB 6PK2215
			16x 12 mm		420 0225 10
314 CDI (906.131, 906.133, 906.135, 906.231, 906.233, ..., 906.631, 906.633, 906.635, 906.637, 906.731, 906.733, 906.735) OM 651.955; (105kW)	05.16-	FAG 	; → 1.850 kg 96 mm		713 6680 10
			; 1.850 kg → 96 mm		713 6680 20
			; ; ; BM 906.132 906.134 906.136		713 6681 10
			right		818 0336 10
			left		818 0335 10
			;		818 0447 10
			↔		840 0373 10
			↔		840 1111 10
					600 0291 00
					624 3408 33
					415 0660 10
					411 0150 10
			314 CDI 4x4 (906.131, 906.133, 906.135, 906.231, 906.233, ..., 906.631, 906.633, 906.635, 906.637, 906.731, 906.733, 906.735) OM 651.955; (105kW)	05.16-	LUK
		624 3408 33			
		415 0660 10			
		411 0150 10			
# F-233197.XX F-559320.XX # F-552901.XX ; START/STOP		535 0050 10			
16x 12 mm		535 0168 10			
16x 12 mm		FB 6PK2215			
16x 12 mm		420 0225 10			
16x 12 mm		422 0099 10			
FAG 		713 6680 30			
96 mm		713 6681 10			
; ; ; BM 906.132 906.134 906.136		713 6681 10			
↔		840 0373 10			
↔		840 1111 10			
315 CDI (906.131, 906.133, 906.135, 906.231, 906.233, ...) OM 646.986; OM 646.989; OM 646.990; (110kW)	06.06-12.09	LUK 	G6 ; NSG 370 ; ID 711.651	GearBOX	462 0152 10
			G6 ; NSG 400 ; ID 711.660;	GearBOX	462 0238 10
			; Z 515.401/08 Z 515.401/09	GearBOX	462 0313 10
			G6 ; NSG 400 ; ID 711.660; ; Z 515.401/06	GearBOX	462 0332 10
			G6 ; TSG 360 ; ID 711.680	GearBOX	462 0332 10
					624 3247 33
					415 0309 10
					411 0147 10
			; A/C		529 0115 10
			A/C ;		532 0391 20
			; 2x		532 0160 10
			; OPTION		533 0017 10
					534 0481 10
# F-233197.XX F-559320.XX		535 0050 10			
# F-552901.XX		535 0168 10			
		544 0116 10			
		FB 6PK2260			
		538 0224 10			
16x 33 mm		420 0170 10			
		428 0092 10			
		428 0184 10			
1x 		553 0147 10			
1x 		559 0039 10			



			SCHAEFFLER
--	---	--	-------------------

MERCEDES-BENZ

Sprinter (906) 3-t - 5-t

315 CDI (906.131, 906.133, 906.135, 906.231, 906.233, ...) OM 646.986; OM 646.989; OM 646.990; (110kW)	06.06-12.09	FAG	 right	 821 0700 10			
			 left	 821 0699 10			
			 ;  → 1.850 kg	 Set 713 6680 10			
			 96 mm				
			 ;  → 1.850 kg →	 Set 713 6680 20			
			 96 mm				
			 ;  ;  BM 906.132 906.134 906.136	 Set 713 6681 10			
			 right	 818 0336 10			
			 left	 818 0335 10			
			 ; 	 818 0447 10			
			 ↔	 825 0327 10			
			 ↔	 840 0373 10			
				 840 1111 10			
			315 CDI (906.631, 906.633, 906.635, 906.637) OM 646.986; OM 646.989; OM 646.990; (110kW)	06.06-12.09	LUK	 G6 ;  NSG 370 ;  ID 711.651	 GearBOX 462 0152 10
						 G6 ;  NSG 400 ;  ID 711.660 ;  Z 515.401/08 Z 515.401/09	 GearBOX 462 0238 10
						 G6 ;  NSG 400 ;  ID 711.660 ;  Z 515.401/06	 GearBOX 462 0313 10
						 G6 ;  TSG 360 ;  ID 711.680	 GearBOX 462 0332 10
						 SA 522609 08 SA 522609 09	 600 0255 00
						incl.  ; incl.  ; SAC	
						 OM 646.986 ;  SA 522609 11	 600 0260 00
incl.  ; incl.  ; SAC							
SAC	 624 3247 33						
	 415 0309 10						
 SA 522609 08 SA 522609 09	 411 0147 10						
 OM 646.986 ;  SA 522609 11	 411 0160 10						
	 ; A/C	 529 0115 10					
	 ; 	 532 0391 20					
	 ; 2x	 532 0160 10					
	 ; OPTION	 533 0017 10					
		 534 0481 10					
	 # F-233197.XX F-559320.XX	 535 0050 10					
	 # F-552901.XX	 535 0168 10					
		 544 0116 10					
	 ; PTO	 FB 6PK2260					
	 ; PTO	 FB 6PK2285					
	 538 0224 10						
	 420 0170 10						
16x							
 33 mm							
	 428 0092 10						
	 428 0184 10						
1x	 OILP 553 0147 10						
1x	 KIT 559 0039 10						
FAG	 right	 821 0700 10					
	 left	 821 0699 10					
	 ;  → 1.850 kg	 Set 713 6680 10					
	 96 mm						
	 ;  → 1.850 kg →	 Set 713 6680 20					
	 96 mm						
	 ;  ;  BM 906.132 906.134 906.136	 Set 713 6681 10					
	 right	 818 0336 10					
	 left	 818 0335 10					
	 ; 	 818 0447 10					
	 ↔	 825 0327 10					
	 ↔	 840 0373 10					
		 840 1111 10					
	LUK	 G6 ;  NSG 370 ;  ID 711.651	 GearBOX 462 0152 10				
		 G6 ;  NSG 400 ;  ID 711.660 ;  Z 515.401/08 Z 515.401/09	 GearBOX 462 0238 10				
		 G6 ;  NSG 400 ;  ID 711.660 ;  Z 515.401/06	 GearBOX 462 0313 10				
		 SA 522609 08 SA 522609 09	 600 0255 00				
		incl.  ; incl.  ; SAC					
		 OM 646.986 ;  SA 522609 11	 600 0260 00				
		incl.  ; incl.  ; SAC					
SAC		 624 3247 33					
		 415 0309 10					
 SA 522609 08 SA 522609 09		 411 0147 10					
 OM 646.986 ;  SA 522609 11	 411 0160 10						



			SCHAEFFLER
--	---	--	-------------------



























































MERCEDES-BENZ

Sprinter (906) 3-t - 5-t

315 CDI (906.731, 906.733, 906.735)
 OM 646.986; OM 646.989; OM 646.990; (110kW)

06.06-12.09



























A/C ; 		532 0391 20
 ; 2x		532 0160 10
 ; OPTION		533 0017 10
		534 0481 10
 # F-233197.XX F-559320.XX		535 0050 10
 # F-552901.XX		535 0168 10
		544 0116 10
 ; A/C		FB 6PK2260
 ; 2x 		FB 6PK2285
 ; BM =2ND ACC		
A/C		FB 13X975
		538 0224 10
16x		420 0170 10
 33 mm		
		428 0092 10
		428 0184 10
1x		553 0147 10
1x		559 0039 10
FAG 		821 0700 10
		821 0699 10
 ;  → 1.850 kg		713 6680 10
		
 ;  →		713 6680 20
		
 ;  ;  ; 		713 6681 10
		818 0336 10
		818 0335 10
		818 0447 10
		825 0327 10
		840 0373 10
		840 1111 10







































315 CDI 4x4 (906.131, 906.133, 906.135, 906.231, 906.233., 906.631, 906.633, 906.635, 906.637)
 OM 646.986; OM 646.989; OM 646.990; (110kW)

02.08-12.09



G6 ;  NSG 400 ;  ID 711.660 ;  Z 515.401/09	GearBOX	462 0238 10
G6 ;  NSG 400 ;  ID 711.660 ;  Z 515.401/06	GearBOX	462 0313 10
G6 ;  TSG 360 ;  ID 711.680	GearBOX	462 0332 10
 SA 522609 08 SA 522609 09		600 0255 00
incl.  ; incl.  ; SAC		
 OM 646.986 ;  SA 522609 11		600 0260 00
incl.  ; incl.  ; SAC		
SAC		624 3247 33
		415 0309 10
 SA 522609 08 SA 522609 09		411 0147 10
 OM 646.986 ;  SA 522609 11		411 0160 10











A/C ; 		532 0391 20
 ; 2x		532 0160 10
 ; OPTION		533 0017 10
		534 0481 10
 # F-233197.XX F-559320.XX		535 0050 10
 # F-552901.XX		535 0168 10
		544 0116 10
 ; A/C		FB 6PK2260
		538 0224 10
16x		420 0170 10
 33 mm		
		428 0092 10
		428 0184 10
1x		553 0147 10
1x		559 0039 10
FAG 		713 6680 30
		
 ;  ;  ; 		713 6681 10
		825 0327 10
		840 0373 10
		840 1111 10

315 CDI 4x4 (906.731, 906.733, 906.735)
 OM 646.986; OM 646.989; OM 646.990; (110kW)

02.08-12.09



 SA 522609 08 SA 522609 09		600 0255 00
incl.  ; incl.  ; SAC		
 OM 646.986 ;  SA 522609 11		600 0260 00
incl.  ; incl.  ; SAC		





MERCEDES-BENZ

Sprinter (906) 3-t - 5-t

<p>315 CDI 4x4 (906.731, 906.733, 906.735) OM 646.986; OM 646.989; OM 646.990; (110kW)</p>	<p>02.08-12.09</p>	<p>LUK</p> <p>INA</p> <p>FAG</p>	<p>SAC</p> <p>SA 522609 08 SA 522609 09 OM 646.986; SA 522609 11</p> <p>A/C ; A/C ; 2x ; OPTION F-233197.XX F-559320.XX F-552901.XX</p> <p>A/C</p> <p>16x 33 mm</p> <p>1x OILP</p> <p>1x KIT</p> <p>96 mm BM 906.132 906.134 906.136</p> <p>right left</p>	<p>624 3247 33 415 0309 10 411 0147 10 411 0160 10 532 0391 20 532 0160 10 533 0017 10 534 0481 10 535 0050 10 535 0168 10 544 0116 10 FB 6PK2260 538 0224 10 420 0170 10 428 0092 10 428 0184 10 553 0147 10 559 0039 10 713 6680 30 713 6681 10 825 0327 10 840 0373 10 840 1111 10</p>	
<p>316 (906.133, 906.135, 906.233, 906.235, 906.635, 906.633) M 271.951; (115kW)</p>	<p>09.08-</p>	<p>LUK</p> <p>INA</p> <p>FAG</p>	<p>SAC</p> <p>→03.09; →31216219 03.09→; 31216220→ F-232001.XX F-557311.XX</p> <p>16x; 31216220→ 12 mm</p> <p>16x; →31216219 12 mm</p> <p>16x; 31216220→ 1x; BS</p> <p>right left right left</p>	<p>624 3247 33 532 0401 30 532 0648 10 534 0081 30 534 0370 10 535 0042 10 535 0165 10 420 0086 10 422 0144 10 559 0045 10 559 0051 10 713 6680 10 713 6680 20 713 6681 10 818 0336 10 818 0335 10 818 0447 10 825 0327 10 840 0373 10 840 1111 10</p>	
<p>316 (906.733, 906.735) M 271.951; (115kW)</p>	<p>09.08-</p>	<p>LUK</p> <p>INA</p> <p>FAG</p>	<p>SAC</p> <p>→03.09; →31216219 03.09→; 31216220→ F-232001.XX F-557311.XX</p> <p>16x; 31216220→ 12 mm</p> <p>16x; →31216219 12 mm</p> <p>16x; 31216220→ 1x; BS</p> <p>right left</p>	<p>624 3247 33 532 0401 30 532 0648 10 534 0081 30 534 0370 10 535 0042 10 535 0165 10 420 0086 10 422 0144 10 559 0045 10 559 0051 10 821 0700 10 821 0699 10</p>	



			SCHAEFFLER
--	---	--	-------------------

MERCEDES-BENZ

Sprinter (906) 3-t - 5-t

316 (906.733, 906.735) M 271.951; (115kW)	09.08-	FAG	; → 1.850 kg		713 6680 10	
			96 mm			
			; 1.850 kg →		713 6680 20	
			96 mm			
			; ; BM 906.132 906.134 906.136		713 6681 10	
			right		818 0336 10	
			left		818 0335 10	
			;		818 0447 10	
			↔		825 0327 10	
			↔		840 0373 10	
					840 1111 10	
					600 0291 00	
					624 3408 33	
					415 0660 10	
		411 0150 10				
316 CDI (906.131, 906.133, 906.135, 906.231, 906.233, ...) OM 651.955; OM 651.957; (120kW)	03.09-	LUK	incl.			
			SAC		624 3408 33	
					415 0660 10	
					411 0150 10	
			; START/STOP A/C		529 0361 10	
			; A/C		532 0108 10	
			;		532 0570 10	
			;		532 0608 10	
					532 0671 10	
					532 0672 10	
			; START/STOP		534 0337 10	
			; START/STOP		534 0444 10	
			# F-233197.XX F-559320.XX		535 0050 10	
			; START/STOP		FB 6PK2215	
			; →08.10; →S 495102; START/STOP		538 0221 10	
					420 0225 10	
			16x			
			12 mm			
			16x		422 0099 10	
			FAG	; → 1.850 kg		713 6680 10
				96 mm		
				; 1.850 kg →		713 6680 20
96 mm						
; ; BM 906.132 906.134 906.136		713 6681 10				
right		818 0336 10				
left		818 0335 10				
;		818 0447 10				
↔		825 0327 10				
↔		840 0373 10				
		840 1111 10				
		600 0291 00				
		624 3408 33				
		415 0660 10				
		411 0150 10				
INA	; START/STOP A/C		529 0361 10			
	; A/C		532 0108 10			
	;		532 0570 10			
	;		532 0608 10			
			532 0671 10			
			532 0672 10			
	; START/STOP		534 0337 10			
	; START/STOP		534 0444 10			
	# F-233197.XX F-559320.XX		535 0050 10			
	; START/STOP		FB 6PK2215			
	; →08.10; →S 495102; START/STOP		538 0221 10			
			420 0225 10			
	16x					
	12 mm					
	16x		422 0099 10			
	FAG	right		821 0700 10		
		left		821 0699 10		
		; → 1.850 kg		713 6680 10		
		96 mm				
	; 1.850 kg →		713 6680 20			
	96 mm					





MERCEDES-BENZ

MERCEDES-BENZ							
Sprinter (906) 3-t - 5-t 316 CDI (906.631, 906.633, 906.635, 906.637) OM 651.955; OM 651.957; (120kW)	03.09-	FAG	; BM 906.132 906.134 906.136		713 6681 10		
			right		818 0336 10		
			left		818 0335 10		
			;		818 0447 10		
			↔		825 0327 10		
			↔		840 0373 10		
					840 1111 10		
					600 0291 00		
					624 3408 33		
					415 0660 10		
					411 0150 10		
			; START/STOP A/C		529 0361 10		
			; A/C		532 0108 10		
			;		532 0570 10		
			;		532 0608 10		
		532 0671 10					
; START/STOP		534 0337 10					
; START/STOP		534 0444 10					
; # F-233197.XX F-559320.XX		535 0050 10					
; START/STOP		FB 6PK2215					
16x		420 0225 10					
12 mm							
16x		422 0099 10					
316 CDI (906.731, 906.733, 906.735) OM 651.955; OM 651.957; (120kW)	08.11-	FAG	; → 1.850 kg 96 mm		713 6680 10		
			; 1.850 kg → 96 mm		713 6680 20		
			; BM 906.132 906.134 906.136		713 6681 10		
			;		818 0447 10		
			↔		825 0327 10		
			↔		840 0373 10		
					840 1111 10		
					600 0291 00		
					624 3408 33		
					415 0660 10		
					411 0150 10		
			; START/STOP A/C		529 0361 10		
			; A/C		532 0108 10		
			;		532 0570 10		
			;		532 0608 10		
		532 0671 10					
; START/STOP		534 0337 10					
; START/STOP		534 0444 10					
; # F-233197.XX F-559320.XX		535 0050 10					
; START/STOP		FB 6PK2215					
; →08.10; →S 495102; START/STOP		538 0221 10					
16x		420 0225 10					
12 mm							
16x		422 0099 10					
316 CDI 4x4 (906.131, 906.133, 906.135, 906.231, 906.233..., 906.631, 906.633, 906.635, 906.637) OM 651.955; OM 651.957; (120kW)	03.09-	LUK	incl. ○		600 0291 00		
			SAC		624 3408 33		
					415 0660 10		
					411 0150 10		
			; START/STOP A/C		529 0361 10		
			; A/C		532 0108 10		
			;		532 0570 10		
			;		532 0608 10		
					532 0671 10		
			; START/STOP		534 0337 10		
			; START/STOP		534 0444 10		
			; # F-233197.XX F-559320.XX		535 0050 10		
			; START/STOP		FB 6PK2215		
			; →08.10; →S 495102; START/STOP		538 0221 10		
			16x		420 0225 10		
12 mm							
16x		422 0099 10					
316 CDI 4x4 (906.731, 906.733, 906.735) OM 651.955; OM 651.957; (120kW)	08.11-	LUK	incl. ○		600 0291 00		
			SAC		624 3408 33		
					415 0660 10		
					411 0150 10		
			; START/STOP A/C		529 0361 10		



			<p>SCHAEFFLER</p>
--	--	--	--------------------------

MERCEDES-BENZ





















































































































Sprinter (906) 3-t - 5-t

316 CDI 4x4 (906.731, 906.733, 906.735) 08.11-
 OM 651.955; OM 651.957;
 (120kW)

316 LGT
 M 271.951; (115kW)

316 LGT (906.133, 906.135, 906.233, 906.235)
 M 271.951; (115kW)

















































































































































316 LGT (906.633, 906.635)
 M 271.951; (115kW)

	100 ; (-ACC) 100 ;  100 ;  100 100 100 ; START/STOP 100 ; START/STOP # F-233197.XX F-559320.XX # F-552901.XX 100 ; START/STOP 16x  12 mm 16x FAG  96 mm  ;  ;  ;  BM 906.132 906.134 906.136  ↔  ↔ 	 532 0108 10  532 0570 10  532 0608 10  532 0671 10  532 0672 10  534 0337 10  534 0444 10  535 0050 10  535 0168 10  FB 6PK2215  420 0225 10  422 0099 10  Set 713 6680 30  Set 713 6681 10  825 0327 10  840 0373 10  840 1111 10
	SAC # F-232001.XX # F-557311.XX 16x;  31216220→  12 mm 16x;  →31216219  12 mm 16x;  31216220→ 1x;  BS FAG  ;  → 1.850 kg  96 mm  ;  1.850 kg →  96 mm  ;  ;  ;  BM 906.132 906.134 906.136  ;   ↔  ↔ 	 624 3247 33  535 0042 10  535 0165 10  420 0086 10  420 0218 10  422 0144 10  KIT 559 0045 10  KIT 559 0051 10  Set 713 6680 10  Set 713 6680 20  Set 713 6681 10  818 0447 10  825 0327 10  840 0373 10  840 1111 10  624 3247 33  411 0148 10
	SAC # F-232001.XX # F-557311.XX 16x;  31216220→  12 mm 16x;  →31216219  12 mm 16x;  31216220→ 1x;  BS FAG  ;  → 1.850 kg  96 mm  ;  1.850 kg →  96 mm  ;  ;  ;  BM 906.132 906.134 906.136  ;   ↔  ↔ 	 532 0648 10  535 0042 10  535 0165 10  420 0086 10  420 0218 10  422 0144 10  KIT 559 0045 10  KIT 559 0051 10  Set 713 6680 10  Set 713 6680 20  Set 713 6681 10  818 0447 10  825 0327 10  840 0373 10  840 1111 10  624 3247 33  411 0148 10
	SAC # F-232001.XX # F-557311.XX 16x;  31216220→  12 mm 16x;  →31216219  12 mm	 532 0648 10  535 0042 10  535 0165 10  420 0086 10  420 0218 10



			SCHAEFFLER
--	--	--	-------------------

MERCEDES-BENZ

Sprinter (906) 3-t - 5-t							
316 LGT (906.633, 906.635) M 271.951; (115kW)	09.08-	 FAG	16x;  31216220→	 422 0144 10			
			1x;  31216220	 559 0045 10			
			1x;  31216220 BS	 559 0051 10			
			 ;  → 1.850 kg	 713 6680 10			
			 ;  1.850 kg →	 713 6680 20			
			 ;  96 mm				
			 ;  96 mm				
			 ;  ;  BM 906.132 906.134 906.136	 713 6681 10			
			 ; 	 818 0447 10			
			 ↔	 825 0327 10			
			 ↔	 840 0373 10			
				 840 1111 10			
				 624 3247 33			
			316 NGT (906.133, 906.135, 906.233, 906.235) M 271.951; (115kW)	09.08-	 FAG	SAC	 411 0148 10
							 532 0401 30
	 532 0648 10						
 ; →03.09;  →31216219	 534 0081 30						
 ; 03.09 →;  31216220→	 534 0370 10						
 # F-232001.XX	 535 0042 10						
 # F-557311.XX	 535 0165 10						
16x;  31216220→	 420 0086 10						
 12 mm							
16x;  →31216219	 420 0218 10						
 12 mm							
16x;  31216220→	 422 0144 10						
1x;  31216220	 559 0045 10						
1x;  31216220 BS	 559 0051 10						
 ;  → 1.850 kg	 713 6680 10						
 ;  1.850 kg →	 713 6680 20						
 ;  96 mm							
 ;  96 mm							
 ;  ;  BM 906.132 906.134 906.136	 713 6681 10						
 right	 818 0336 10						
 left	 818 0335 10						
 ; 	 818 0447 10						
 ↔	 825 0327 10						
 ↔	 840 0373 10						
	 840 1111 10						
	 624 3247 33						
316 NGT (906.633, 906.635) M 271.951; (115kW)	09.08-	 FAG				SAC	 411 0148 10
				 532 0648 10			
			 # F-232001.XX	 535 0042 10			
			 # F-557311.XX	 535 0165 10			
			16x;  31216220→	 420 0086 10			
			 12 mm				
			16x;  →31216219	 420 0218 10			
			 12 mm				
			16x;  31216220→	 422 0144 10			
			1x;  31216220	 559 0045 10			
			1x;  31216220 BS	 559 0051 10			
			 ;  → 1.850 kg	 713 6680 10			
			 ;  1.850 kg →	 713 6680 20			
			 ;  96 mm				
			 ;  96 mm				
			 ;  ;  BM 906.132 906.134 906.136	 713 6681 10			
			 ; 	 818 0447 10			
			 ↔	 825 0327 10			
			 ↔	 840 0373 10			
				 840 1111 10			
				 626 3026 33			
			318 CDI (906.131, 906.133, 906.135, 906.231, 906.233, ... 906.631, 906.633, 906.635, 906.637) OM 642.896; OM 642.986; OM 642.992; OM 642.993; (135kW)	06.06-12.09	 FAG	G6;  NSG 370;  ID 711.651	GearBOX 462 0152 10
						G6;  NSG 400;  ID 711.660;	GearBOX 462 0238 10
						 Z 515.401/08 Z 515.401/09	
						G6;  NSG 400;  ID 711.660;  Z 515.401/06	GearBOX 462 0313 10
						G6;  TSG 360;  ID 711.680	GearBOX 462 0332 10
						SAC	 626 3026 33
	 415 0304 10						
	 411 0147 10						



			SCHAEFFLER
--	---	--	-------------------

MERCEDES-BENZ

Sprinter (906) 3-t - 5-t

318 CDI (906.131, 906.133, 906.135, 906.231, 906.233, ..., 906.631, 906.633, 906.635, 906.637)
 OM 642.896; OM 642.986; OM 642.992; OM 642.993; (135kW)

06.06-12.09



; 2x		532 0234 10
A/C		532 0566 10
; OM 642.992 OM 642.993		534 0183 10
A/C		534 0257 10
; START/STOP; OM 642.896		534 0506 10
# F-233197.XX F-559320.XX		535 0050 10
# F-239808.XX		535 0140 10
HYDP; A/C		FB 6PK1413
; A/C; # OE 0019933696		FB 7PK1973
; PTO; A/C		FB 7PK2035
; A/C		FB 7PK2045
		538 0234 10
24x		420 0086 10
12 mm		
24x		422 0056 10
1x		558 0039 10
1x		559 0049 10
1x		559 0050 10
1x		559 0087 10
1x		559 0088 10
1x		558 0040 10
FAG right		821 0700 10
left		821 0699 10
; → 1.850 kg		713 6680 10
96 mm		
; 1.850 kg →		713 6680 20
96 mm		
; BM 906.132 906.134 906.136		713 6681 10
right		818 0336 10
left		818 0335 10
;		818 0447 10
↔		825 0327 10
↔		840 0373 10
		840 1111 10

318 CDI (906.731, 906.733, 906.735)
 OM 642.896; OM 642.986; OM 642.992; OM 642.993; (135kW)

02.08-12.09



G6; NSG 370; ID 711.651	GearBOX	462 0152 10
SAC		626 3026 33
		415 0304 10
		411 0147 10
; 2x		532 0234 10
A/C		532 0566 10
; OM 642.992 OM 642.993		534 0183 10
A/C		534 0257 10
; START/STOP; OM 642.896		534 0506 10
# F-232001.XX		535 0042 10
# F-233197.XX F-559320.XX		535 0050 10
# F-239808.XX		535 0140 10
# F-552901.XX		535 0168 10
HYDP; A/C		FB 6PK1413
; A/C; # OE 0019933696		FB 7PK1973
; PTO; A/C		FB 7PK2035
; A/C		FB 7PK2045
		538 0234 10
24x		420 0086 10
12 mm		
24x		422 0056 10
1x		558 0039 10
1x		559 0049 10
1x		559 0050 10
1x		559 0087 10
1x		559 0088 10
1x		558 0040 10
FAG right		821 0700 10
left		821 0699 10
; → 1.850 kg		713 6680 10
96 mm		
; 1.850 kg →		713 6680 20
96 mm		
; BM 906.132 906.134 906.136		713 6681 10



			SCHAEFFLER
--	--	--	-------------------

MERCEDES-BENZ

Sprinter (906) 3-t - 5-t



































































<p>318 CDI (906.731, 906.733, 906.735) OM 642.896; OM 642.986; OM 642.992; OM 642.993; (135kW)</p>	<p>02.08-12.09</p>	<p>FAG</p>	<p> right left ↔ ↔ </p>	<p> 818 0336 10 818 0335 10 818 0447 10 825 0327 10 840 0373 10 840 1111 10</p>
<p>318 CDI 4x4 (906.131, 906.133, 906.135, 906.231, 906.233..) OM 642.896; OM 642.992; OM 642.993; (135kW)</p>	<p>02.08-12.09</p>	<p>LUK</p>	<p>G6; NSG 400; ID 711.660; Z 515.401/08 Z 515.401/09 G6; NSG 400; ID 711.660; Z 515.401/06 G6; TSG 360; ID 711.680 SAC</p>	<p>GearBOX 462 0238 10 GearBOX 462 0313 10 GearBOX 462 0332 10 626 3026 33 415 0304 10 411 0147 10 529 0050 10 532 0234 10 532 0566 10 534 0183 10 534 0257 10 534 0506 10 535 0050 10 535 0140 10 535 0140 10 FB 6PK1413 FB 7PK1973 FB 7PK2035 FB 7PK2045 538 0234 10 420 0086 10 422 0056 10 558 0039 10 559 0049 10 559 0050 10 559 0087 10 559 0088 10 558 0040 10</p>
<p>318 CDI 4x4 (906.631, 906.633, 906.635, 906.637) OM 642.896; OM 642.986; OM 642.992; OM 642.993; (135kW)</p>	<p>02.08-12.09</p>	<p>FAG</p>	<p> 96 mm BM 906.132 906.134 906.136 ↔ ↔ </p>	<p> Set 713 6680 30 Set 713 6681 10 825 0327 10 840 0373 10 840 1111 10</p>
<p>318 CDI 4x4 (906.631, 906.633, 906.635, 906.637) OM 642.896; OM 642.986; OM 642.992; OM 642.993; (135kW)</p>	<p>02.08-12.09</p>	<p>LUK</p>	<p>G6; NSG 400; ID 711.660; Z 515.401/08 Z 515.401/09 G6; NSG 400; ID 711.660; Z 515.401/06 G6; TSG 360; ID 711.680 SAC</p>	<p>GearBOX 462 0238 10 GearBOX 462 0313 10 GearBOX 462 0332 10 626 3026 33 415 0304 10 411 0147 10 529 0050 10 532 0234 10 532 0566 10 534 0183 10 534 0257 10 534 0506 10 535 0042 10 535 0050 10 535 0140 10 535 0168 10 535 0168 10 FB 6PK1413 FB 7PK1973 FB 7PK2035 FB 7PK2045 538 0234 10 420 0086 10 422 0056 10 558 0039 10 559 0049 10</p>



			SCHAEFFLER
--	--	--	-------------------

MERCEDES-BENZ

Sprinter (906) 3-t - 5-t

318 CDI 4x4 (906.631, 906.633, 906.635, 906.637) OM 642.896; OM 642.986; OM 642.992; OM 642.993; (135kW)	02.08-12.09	 FAG	1x		559 0050 10
			1x		559 0087 10
			1x		559 0088 10
			1x		558 0040 10
			 96 mm		713 6680 30
			 BM 906.132 906.134 906.136		713 6681 10
			 ↔		825 0327 10
			 ↔		840 0373 10
					840 1111 10
					626 3026 33
					415 0304 10
					411 0147 10
					529 0050 10
					532 0234 10
					532 0566 10
		534 0183 10			
		534 0257 10			
		534 0506 10			
		535 0042 10			
		535 0050 10			
		535 0140 10			
		535 0168 10			
		FB 6PK1413			
		FB 7PK1973			
		FB 7PK2035			
		FB 7PK2045			
		538 0234 10			
		420 0086 10			
		422 0056 10			
		558 0039 10			
		559 0049 10			
		559 0050 10			
		559 0087 10			
		559 0088 10			
		558 0040 10			
		713 6680 30			
		713 6681 10			
		825 0327 10			
		840 0373 10			
		840 1111 10			
		626 3026 33			
		415 0304 10			
		411 0147 10			
		529 0050 10			
		532 0234 10			
		532 0566 10			
		534 0183 10			
		534 0257 10			
		534 0506 10			
		535 0140 10			
		FB 6PK1413			
		FB 7PK1973			
		FB 7PK2035			
		FB 7PK2045			
		538 0234 10			
		420 0086 10			
		422 0056 10			
		558 0039 10			
		559 0049 10			
		559 0050 10			

319 CDI / BlueTEC (906.131, 906.133, 906.135, 906.231, ..)
 OM 642.896; OM 642.898; OM 642.992; (140kW)

03.09-





MERCEDES-BENZ

Sprinter (906) 3-t - 5-t

319 CDI / BlueTEC (906.131, 906.133, 906.135, 906.231, ...) OM 642.896; OM 642.898; OM 642.992; (140kW)	03.09-		1x; 642.896 642.898; →04.15; →41711428		559 0087 10
			1x; 642.992; →09.14; →41633498		
			1x; 642.896 642.898; →04.15; →41711428		559 0088 10
			1x; 642.992; →09.14; →41633498		
			1x		558 0040 10
			; → 1.850 kg 96 mm		713 6680 10
			; 1.850 kg → 96 mm		713 6680 20
			; ; ; BM 906.132 906.134 906.136		713 6681 10
			right		818 0336 10
			left		818 0335 10
			;		818 0447 10
			↔		825 0327 10
			↔		840 0373 10
					840 1111 10
			319 CDI / BlueTEC (906.631, 906.633, 906.635, 906.637) OM 642.896; OM 642.898; OM 642.986; OM 642.992; (140kW)	03.09-	
OM 642.896		415 0304 10			
OM 642.992					
OM 642.993					
	; START/STOP				529 0050 10
	; 2x				532 0234 10
	A/C				532 0566 10
	; OM 642.992				534 0183 10
	A/C				534 0257 10
	; START/STOP ; OM 642.896 OM 642.898				534 0506 10
	# F-239808.XX				535 0140 10
	HYDP; A/C				FB 6PK1413
	; A/C ; # OE 0019933696				FB 7PK1973
	; P70 ; A/C				FB 7PK2035
	; A/C				FB 7PK2045
		538 0234 10			
24x 12 mm		420 0086 10			
24x		422 0056 10			
1x; 642.896 642.898; →04.15; →41711428		558 0039 10			
1x; 642.986 642.992; →09.14; →41633498					
1x; 642.896 642.898; →04.15; →41711428		559 0087 10			
1x; 642.986 642.992; →09.14; →41633498					
1x; 642.896 642.898; →04.15; →41711428		559 0088 10			
1x; 642.986 642.992; →09.14; →41633498					
1x		558 0040 10			
	; → 1.850 kg 96 mm		713 6680 10		
	; 1.850 kg → 96 mm		713 6680 20		
	; ; ; BM 906.132 906.134 906.136		713 6681 10		
	right		818 0336 10		
	left		818 0335 10		
	;		818 0447 10		
	↔		825 0327 10		
	↔		840 0373 10		
			840 1111 10		
	319 CDI / BlueTEC (906.731, 906.733, 906.735) OM 642.896; OM 642.898; OM 642.986; OM 642.992; (140kW)	03.09-		SAC	
OM 642.896					415 0304 10
OM 642.992					
OM 642.993					
			; 2x		532 0234 10
			A/C		532 0566 10
			; OM 642.992		534 0183 10
			A/C		534 0257 10
			; START/STOP ; OM 642.896 OM 642.898		534 0506 10
			# F-232001.XX		535 0042 10
			# F-239808.XX		535 0140 10
			# F-552901.XX		535 0168 10
			HYDP; A/C		FB 6PK1413



			<p>SCHAEFFLER</p>	
--	--	--	--------------------------	--

MERCEDES-BENZ

Sprinter (906) 3-t - 5-t

319 CDI / BlueTEC (906.731, 906.733, 906.735)

OM 642.896; OM 642.898; OM 642.986; OM 642.992; (140kW)

03.09-



<p>1; A/C; # OE 0019933696</p>		<p>FB 7PK1973</p>
<p>1; PTO; A/C</p>		<p>FB 7PK2035</p>
<p>1; A/C</p>		<p>FB 7PK2045</p>
<p>24x</p>		<p>538 0234 10</p>
<p>12 mm</p>		<p>420 0086 10</p>
<p>24x</p>		<p>422 0056 10</p>
<p>1x; OM 642.896 642.898; →04.15; →41711428</p>		<p>558 0039 10</p>
<p>1x; OM 642.986 642.992; →09.14; →41633498</p>		<p>559 0087 10</p>
<p>1x; OM 642.896 642.898; →04.15; →41711428</p>		<p>559 0087 10</p>
<p>1x; OM 642.986 642.992; →09.14; →41633498</p>		<p>559 0088 10</p>
<p>1x; OM 642.896 642.898; →04.15; →41711428</p>		<p>559 0088 10</p>
<p>1x; OM 642.986 642.992; →09.14; →41633498</p>		<p>559 0088 10</p>
<p>1x</p>		<p>558 0040 10</p>
<p>FAG</p>	<p>right</p>	<p>821 0700 10</p>
<p>left</p>		<p>821 0699 10</p>
<p>1.850 kg</p>		<p>713 6680 10</p>
<p>96 mm</p>		<p>713 6680 20</p>
<p>1.850 kg →</p>		<p>713 6680 20</p>
<p>96 mm</p>		<p>713 6681 10</p>
<p>BM 906.132 906.134 906.136</p>		<p>713 6681 10</p>
<p>right</p>		<p>818 0336 10</p>
<p>left</p>		<p>818 0335 10</p>
<p>BM</p>		<p>818 0447 10</p>
<p>↔</p>		<p>825 0327 10</p>
<p>↔</p>		<p>840 0373 10</p>
<p>BM</p>		<p>840 1111 10</p>

319 CDI / BlueTEC 4x4 (906.131, 906.133, 906.135, ...)

OM 642.896; OM 642.898; OM 642.992; (140kW)

05.11-



<p>OM 642.992</p>		<p>626 3026 19</p>
<p>SAC</p>		<p>626 3026 33</p>
<p>OM 942.992</p>		<p>415 0304 10</p>
<p>SAC</p>		<p>411 0147 10</p>



<p>2x</p>		<p>532 0234 10</p>
<p>A/C</p>		<p>532 0566 10</p>
<p>OM 642.992</p>		<p>534 0183 10</p>
<p>A/C</p>		<p>534 0257 10</p>
<p>START/STOP; OM 642.896 OM 642.898</p>		<p>534 0506 10</p>
<p>F-232001.XX</p>		<p>535 0042 10</p>
<p>F-239808.XX</p>		<p>535 0140 10</p>
<p>F-552901.XX</p>		<p>535 0168 10</p>
<p>HYDP; A/C</p>		<p>FB 6PK1413</p>
<p>A/C; # OE 0019933696</p>		<p>FB 7PK1973</p>
<p>PTO; A/C</p>		<p>FB 7PK2035</p>
<p>A/C</p>		<p>FB 7PK2045</p>
<p>24x</p>		<p>538 0234 10</p>
<p>12 mm</p>		<p>420 0086 10</p>
<p>24x</p>		<p>422 0056 10</p>
<p>1x; OM 642.896 642.898; →04.15; →41711428</p>		<p>558 0039 10</p>
<p>1x; OM 642.992; →09.14; →41633498</p>		<p>559 0087 10</p>
<p>1x; OM 642.896 642.898; →04.15; →41711428</p>		<p>559 0087 10</p>
<p>1x; OM 642.992; →09.14; →41633498</p>		<p>559 0088 10</p>
<p>1x; OM 642.896 642.898; →04.15; →41711428</p>		<p>559 0088 10</p>
<p>1x; OM 642.992; →09.14; →41633498</p>		<p>559 0088 10</p>
<p>1x</p>		<p>558 0040 10</p>
<p>FAG</p>	<p>96 mm</p>	<p>713 6680 30</p>
<p>BM 906.132 906.134 906.136</p>		<p>713 6681 10</p>
<p>↔</p>		<p>825 0327 10</p>
<p>↔</p>		<p>840 0373 10</p>
<p>BM</p>		<p>840 1111 10</p>

319 CDI / BlueTEC 4x4 (906.631, 906.633, 906.635, ...)

OM 642.896; OM 642.898; OM 642.986; OM 642.992; (140kW)

03.09-





























































<p>SAC</p>		<p>626 3026 33</p>
<p>OM 642.896</p>		<p>415 0304 10</p>
<p>OM 642.992</p>		<p>411 0147 10</p>
<p>OM 642.993</p>		<p>411 0147 10</p>



			SCHAEFFLER
--	---	--	-------------------

MERCEDES-BENZ

Sprinter (906) 3-t - 5-t

319 CDI / BlueTEC 4x4 (906.631, 906.633, 906.635, ...) OM 642.896; OM 642.898; OM 642.986; OM 642.992; (140kW)	03.09-		2x A/C		532 0234 10	
			A/C		532 0566 10	
			OM 642.992		534 0183 10	
			A/C		534 0257 10	
			START/STOP ; OM 642.896 OM 642.898		534 0506 10	
			F-232001.XX		535 0042 10	
			F-239808.XX		535 0140 10	
			F-552901.XX		535 0168 10	
			HYDP; A/C		FB 6PK1413	
			A/C ; # OE 0019933696		FB 7PK1973	
			PTO ; A/C		FB 7PK2035	
			A/C		FB 7PK2045	
			24x 12 mm		538 0234 10	
			24x		420 0086 10	
			1x; OM 642.896 642.898; →04.15; →417.11428		422 0056 10	
			1x; OM 642.986 642.992; →09.14; →41633498		558 0039 10	
			1x; OM 642.896 642.898; →04.15; →41711428		559 0087 10	
			1x; OM 642.986 642.992; →09.14; →41633498		559 0088 10	
			1x; OM 642.896 642.898; →04.15; →41711428		559 0088 10	
			1x; OM 642.986 642.992; →09.14; →41633498		559 0088 10	
1x		558 0040 10				
FAG	96 mm		Set 713 6680 30			
	BM 906.132 906.134 906.136		Set 713 6681 10			
	↔		825 0327 10			
	↔		840 0373 10			
	↔		840 1111 10			
	↔		840 1111 10			
	↔		840 1111 10			
	↔		840 1111 10			
319 CDI / BlueTEC 4x4 (906.731, 906.733, 906.735) OM 642.896; OM 642.898; OM 642.986; OM 642.992; (140kW)	03.09-		SAC		626 3026 33	
			OM 642.896		415 0304 10	
			OM 642.992		415 0304 10	
			OM 642.993		415 0304 10	
			24x 12 mm		411 0147 10	
			24x		422 0056 10	
			1x; OM 642.896 642.898; →04.15; →41711428		558 0039 10	
			1x; OM 642.986 642.992; →09.14; →41633498		559 0087 10	
			1x; OM 642.896 642.898; →04.15; →41711428		559 0088 10	
			1x; OM 642.986 642.992; →09.14; →41633498		559 0088 10	
			1x; OM 642.896 642.898; →04.15; →41711428		559 0088 10	
			1x; OM 642.986 642.992; →09.14; →41633498		559 0088 10	
			1x		558 0040 10	
			FAG	96 mm		Set 713 6680 30
				BM 906.132 906.134 906.136		Set 713 6681 10
				↔		825 0327 10
				↔		840 0373 10
				↔		840 1111 10
				↔		840 1111 10
				↔		840 1111 10
↔		840 1111 10				
324 (906.133, 906.135, 906.233, 906.235, 906.132, ..., 906.633, 906.635, 906.637) M 272.979; (190kW)	06.06-12.13		G6 ; NSG 370 ; ID 711.651		GearBOX 462 0152 10	
			G6 ; NSG 400 ; ID 711.660; Z 515.401/08 Z 515.401/09		GearBOX 462 0238 10	
			G6 ; NSG 400 ; ID 711.660; Z 515.401/06		GearBOX 462 0313 10	
			G6 ; TSG 360 ; ID 711.680		GearBOX 462 0332 10	
			G6 ; TSG 360 ; ID 711.680		GearBOX 462 0332 10	



			<p>SCHAEFFLER</p>
--	---	--	--------------------------

MERCEDES-BENZ

Sprinter (906) 3-t - 5-t

324 (906.133, 906.135, 906.233, 906.235, 906.132, ..., 906.633, 906.635, 906.637)
 M 272.979; (190kW)

06.06-12.13



03.07 →; 30621934 →; A/C		529 0034 10
; A/C		532 0108 10
; →03.07; →30621933		532 0160 10
		532 0539 10
; A/C		532 0667 10
; 03.07 →; 30621934 →		532 0866 10
;		533 0100 10
		534 0067 10
		FB 6PK2403
		538 0244 10
24x		420 0086 10
12 mm		
24x		422 0055 10
1x		553 0147 10
1x		558 0041 10
1x		559 0093 10
FAG right		821 0700 10
left		821 0699 10
; → 1.850 kg		713 6680 10
96 mm		
; 1.850 kg →		713 6680 20
96 mm		
; ; BM 906.132 906.134 906.136		713 6681 10
right		818 0336 10
left		818 0335 10
;		818 0447 10
↔		825 0327 10
↔		840 0373 10
		840 1111 10

324 (906.733, 906.735)
 M 272.979; (190kW)

06.06-12.13



G6; NSG 370; ID 711.651	GearBOX	462 0152 10
G6; NSG 400; ID 711.660;	GearBOX	462 0238 10
Z 515.401/08 Z 515.401/09		
G6; NSG 400; ID 711.660; Z 515.401/06	GearBOX	462 0313 10



03.07 →; 30621934 →; A/C		529 0034 10
; A/C		532 0108 10
; →03.07; →30621933		532 0160 10
		532 0539 10
; A/C		532 0667 10
; 03.07 →; 30621934 →		532 0866 10
;		533 0100 10
		534 0067 10
		FB 6PK2403
		538 0244 10
24x		420 0086 10
12 mm		
24x		422 0055 10
1x		553 0147 10
1x		558 0041 10
1x		559 0093 10
FAG right		821 0700 10
left		821 0699 10
; → 1.850 kg		713 6680 10
96 mm		
; 1.850 kg →		713 6680 20
96 mm		
; ; BM 906.132 906.134 906.136		713 6681 10
right		818 0336 10
left		818 0335 10
;		818 0447 10
↔		825 0327 10
↔		840 0373 10
		840 1111 10

411 CDI (906.153, 906.155, 906.253, 906.255, 906.653, 906.655, 906.657)
 OM 646.985; (80kW)

06.09-12.18









































































































G6; NSG 400; ID 711.660;	GearBOX	462 0238 10
Z 515.401/08 Z 515.401/09		
G6; NSG 400; ID 711.660; Z 515.401/06	GearBOX	462 0313 10
G6; TSG 360; ID 711.680	GearBOX	462 0332 10
incl. ; incl. ; SAC		600 0255 00
SAC		624 3247 33



			SCHAEFFLER
--	--	--	-------------------

MERCEDES-BENZ





















































































































































Sprinter (906) 3-t - 5-t													
411 CDI (906.153, 906.155, 906.253, 906.255, 906.653, 906.655, 906.657) OM 646.985; (80kW)	06.09-12.18	  FAG	 415 0309 10  411 0147 10  532 0108 10  532 0160 10  OPTION 533 0017 10  534 0481 10   # F-233197.XX F-559320.XX 535 0050 10  544 0116 10  A/C FB 6PK2260  538 0224 10  16x 420 0170 10  33 mm   428 0092 10   428 0184 10  Set 713 6680 10  Set 713 6680 20   BM 906.132 906.134 906.136 Set 713 6681 10   818 0447 10   825 0327 10   840 0373 10  840 1111 10  600 0291 00										
			413 CDI OM 651.955; (95kW)	03.09-	  FAG	 incl.  SAC  624 3408 33  415 0660 10   BM 909.643;  OM 611* OM 646*  # F-233197.XX F-559320.XX  START/STOP  FB 6PK2215   ; →08.10;  →S 495102; START/STOP  16x  420 0225 10  12 mm  16x  422 0099 10  Set 713 6680 10  Set 713 6680 20   BM 906.132 906.134 906.136 Set 713 6681 10							
						413 CDI (906.653, 906.655, 906.657) OM 651.955; OM 651.956; (95kW)	06.06-05.16	  FAG	 incl.  SAC  624 3408 33  415 0660 10   BM 909.643;  OM 611* OM 646*  # F-233197.XX F-559320.XX  START/STOP  FB 6PK2215   ; →08.10;  →S 495102; START/STOP  16x  420 0225 10  12 mm  16x  422 0099 10  Set 713 6680 10  Set 713 6680 20   BM 906.132 906.134 906.136 Set 713 6681 10  right  818 0336 10  left  818 0335 10   825 0327 10   840 0373 10  840 1111 10  600 0291 00   SAC  624 3408 33  415 0660 10   411 0150 10				
									414 CDI (105kW)	05.16-		 incl.  SAC  624 3408 33  415 0660 10   411 0150 10	



			SCHAEFFLER
--	---	--	-------------------

MERCEDES-BENZ





Sprinter (906) 3-t - 5-t

414 CDI  (105kW)	05.16-		 # F-232001.XX	 535 0042 10
			 # F-233197.XX F-559320.XX	 535 0050 10
			 # F-239808.XX	 535 0140 10
			 # F-552901.XX	 535 0168 10
			 ;  OM 651.357; START/STOP	 FB 6PK2215
			 ;  OM 651.357; START/STOP	
			 ; START/STOP	 FB 6PK2215
			FAG  ;  → 1.850 kg	  713 6680 10
			 96 mm	
			 ;  1.850 kg →	  713 6680 20
			 96 mm	
			 ;  ;  BM 906.132 906.134 906.136	  713 6681 10
			 right	 818 0336 10
			 left	 818 0335 10
			 ↔	 825 0327 10
 ↔	 840 0373 10			
 ↔	 840 1111 10			
415 CDI (906.153, 906.155, 906.253, 906.255)  OM 646.986; OM 646.989; OM 646.990; (110kW)	06.06-12.09		G6 ;  NSG 400 ;  ID 711.660;	GearBOX 462 0238 10
			 Z 515.401/08 Z 515.401/09	
			G6 ;  NSG 400 ;  ID 711.660;  Z 515.401/06	GearBOX 462 0313 10
			G6 ;  TSG 360 ;  ID 711.680	GearBOX 462 0332 10
			 SA 522609 08 SA 522609 09	 600 0255 00
			incl.  ; incl.  ; SAC	
			 OM 646.986;  SA 522609 11	 600 0260 00
			incl.  ; incl.  ; SAC	
			SAC	 624 3247 33
				 415 0309 10
			 SA 522609 08 SA 522609 09	 411 0147 10
			 OM 646.986;  SA 522609 11	 411 0160 10
			 ; A/C	 529 0115 10
			 ; 2x	 532 0160 10
			 ; OPTION	 533 0017 10
	 534 0481 10			
 # F-232001.XX	 535 0042 10			
 # F-233197.XX F-559320.XX	 535 0050 10			
 # F-552901.XX	 535 0168 10			
	 544 0116 10			
	 538 0224 10			
16x	 420 0170 10			
 33 mm				
	 428 0092 10			
	 428 0184 10			
FAG  ;  → 1.850 kg	  713 6680 10			
 96 mm				
 ;  1.850 kg →	  713 6680 20			
 96 mm				
 ;  ;  BM 906.132 906.134 906.136	  713 6681 10			
 right	 818 0336 10			
 left	 818 0335 10			
 ; 	 818 0447 10			
 ↔	 825 0327 10			
 ↔	 840 0373 10			
	 840 1111 10			
415 CDI (906.653, 906.655, 906.657)  OM 646.986; OM 646.989; OM 646.990; (110kW)	06.09-12.09		G6 ;  NSG 400 ;  ID 711.660;	GearBOX 462 0238 10
			 Z 515.401/08 Z 515.401/09	
			G6 ;  NSG 400 ;  ID 711.660;  Z 515.401/06	GearBOX 462 0313 10
			G6 ;  TSG 360 ;  ID 711.680	GearBOX 462 0332 10
			 SA 522609 08 SA 522609 09	 600 0255 00
			incl.  ; incl.  ; SAC	
			 OM 646.986;  SA 522609 11	 600 0260 00
			incl.  ; incl.  ; SAC	
			SAC	 624 3247 33
				 415 0309 10
			 SA 522609 08 SA 522609 09	 411 0147 10
			 OM 646.986;  SA 522609 11	 411 0160 10
			 ; A/C	 529 0115 10
				 532 0108 10



			SCHAEFFLER
--	---	--	-------------------

MERCEDES-BENZ

Sprinter (906) 3-t - 5-t						
415 CDI (906.653, 906.655, 906.657) OM 646.986; OM 646.989; OM 646.990; (110kW)	06.09-12.09		; 2x		532 0160 10	
			; OPTION		533 0017 10	
					534 0481 10	
			# F-233197.XX F-559320.XX		535 0050 10	
					544 0116 10	
					538 0224 10	
			16x		420 0170 10	
			33 mm			
					428 0092 10	
					428 0184 10	
			FAG ; → 1.850 kg	Set	713 6680 10	
			96 mm			
			; 1.850 kg →	Set	713 6680 20	
			96 mm			
			; ; BM 906.132 906.134 906.136	Set	713 6681 10	
;		818 0447 10				
↔		825 0327 10				
↔		840 0373 10				
		840 1111 10				
		600 0291 00				
416 CDI (906.153, 906.155, 906.253, 906.255) OM 651.955; OM 651.957; (120kW)	03.09-		incl.		624 3408 09	
			SAC		624 3408 33	
			SAC		415 0660 10	
					411 0150 10	
				; START/STOP A/C		529 0361 10
			; A/C		532 0108 10	
			;		532 0570 10	
			;		532 0608 10	
					532 0671 10	
					532 0672 10	
			; START/STOP		534 0337 10	
			; START/STOP		534 0444 10	
			# F-233197.XX F-559320.XX		535 0050 10	
			; START/STOP		FB 6PK2215	
			; START/STOP		538 0221 10	
16x		420 0225 10				
12 mm						
16x		422 0099 10				
FAG ; → 1.850 kg	Set	713 6680 10				
96 mm						
; 1.850 kg →	Set	713 6680 20				
96 mm						
; ; BM 906.132 906.134 906.136	Set	713 6681 10				
right		818 0336 10				
left		818 0335 10				
;		818 0447 10				
↔		825 0327 10				
↔		840 0373 10				
		840 1111 10				
		624 3408 33				
		415 0660 10				
		411 0150 10				
416 CDI (906.653, 906.655, 906.657) OM 651.955; OM 651.957; (120kW)	03.09-		SAC		624 3408 33	
					415 0660 10	
					411 0150 10	
				; START/STOP A/C		529 0361 10
			; A/C		532 0108 10	
			;		532 0570 10	
			;		532 0608 10	
					532 0671 10	
					532 0672 10	
			; START/STOP		534 0337 10	
			; START/STOP		534 0444 10	
			# F-233197.XX F-559320.XX		535 0050 10	
			; START/STOP		FB 6PK2215	
			; →08.10; →S 495102; START/STOP		538 0221 10	



			<p>SCHAEFFLER</p>
--	---	--	--------------------------

MERCEDES-BENZ

Sprinter (906) 3-t - 5-t

416 CDI (906.653, 906.655, 906.657)
 OM 651.955; OM 651.957;
 (120kW)

03.09-



16x		420 0225 10
12 mm		
16x		422 0099 10
; → 1.850 kg		713 6680 10
96 mm		
; 1.850 kg →		713 6680 20
96 mm		
; ; ; BM 906.132 906.134 906.136		713 6681 10
right		818 0336 10
left		818 0335 10
;		818 0447 10
↔		825 0327 10
↔		840 0373 10
		840 1111 10

418 CDI (906.153, 906.155, 906.253,
 906.255)
 OM 642.896; OM 642.986; OM
 642.992; OM 642.993; (135kW)

06.06-12.09



G6 ; NSG 400 ; ID 711.660 ; Z 515.401/08 Z 515.401/09		462 0238 10
G6 ; TSG 360 ; ID 711.680		462 0332 10
SAC		626 3026 33
		415 0304 10
		411 0147 10
; START/STOP		529 0050 10
; 2x		532 0234 10
A/C		532 0566 10
; OM 642.992 OM 642.993		534 0183 10
A/C		534 0257 10
; START/STOP ; OM 642.896		534 0506 10
# F-232001.XX		535 0042 10
# F-239808.XX		535 0140 10
# F-552901.XX		535 0168 10
HYDP; A/C		FB 6PK1413
; A/C ; # OE 0019933696		FB 7PK1973
; PTO ; A/C		FB 7PK2035
; A/C		FB 7PK2045
		538 0234 10
24x		420 0086 10
12 mm		
24x		422 0056 10
1x		558 0039 10
1x		559 0087 10
1x		559 0088 10
1x		558 0040 10



; → 1.850 kg		713 6680 10
96 mm		
; 1.850 kg →		713 6680 20
96 mm		
; ; ; BM 906.132 906.134 906.136		713 6681 10
right		818 0336 10
left		818 0335 10
;		818 0447 10
↔		825 0327 10
↔		840 0373 10
		840 1111 10

418 CDI (906.653, 906.655, 906.657)
 OM 642.896; OM 642.986; OM
 642.992; (135kW)

06.09-05.16









































































































































G6 ; NSG 400 ; ID 711.660 ; Z 515.401/08 Z 515.401/09		462 0238 10
G6 ; NSG 400 ; ID 711.660 ; Z 515.401/06		462 0313 10
G6 ; TSG 360 ; ID 711.680		462 0332 10
SAC		626 3026 33
		415 0304 10
		411 0147 10
; START/STOP		529 0050 10
; 2x		532 0234 10
A/C		532 0566 10
; OM 642.992		534 0183 10
A/C		534 0257 10
; START/STOP ; OM 642.896		534 0506 10
# F-239808.XX		535 0140 10
HYDP; A/C		FB 6PK1413
; A/C ; # OE 0019933696		FB 7PK1973



			SCHAEFFLER
--	---	--	-------------------

MERCEDES-BENZ

Sprinter (906) 3-t - 5-t

418 CDI (906.653, 906.655, 906.657) OM 642.896; OM 642.986; OM 642.992; (135kW)	06.09-05.16		 ;  ; A/C		FB 7PK2035
			 ; A/C		FB 7PK2045
			24x		538 0234 10
			 12 mm		420 0086 10
			24x		422 0056 10
			1x;  642.896; →04.15;  →41711428		558 0039 10
			1x;  642.986 642.992; →09.14;  →41633498		
			1x;  642.896; →04.15;  →41711428		559 0087 10
			1x;  642.986 642.992; →09.14;  →41633498		
			1x;  642.896; →04.15;  →41711428		559 0088 10
			1x;  642.986 642.992; →09.14;  →41633498		
			1x		558 0040 10
		FAG	 ;  → 1.850 kg		713 6680 10
			 96 mm		713 6680 20
			 ;  1.850 kg →		713 6680 20
			 96 mm		713 6681 10
			 ;  ;  ;  BM 906.132 906.134 906.136		818 0447 10
					825 0327 10
					840 0373 10
					840 1111 10
			626 3026 33		
			415 0304 10		
419 CDI (906.153, 906.155, 906.253, 906.255) OM 642.896; OM 642.986; OM 642.992; (140kW)	03.09-		SAC		626 3026 33
			 OM 642.896		415 0304 10
			 OM 642.992		
			 OM 642.993		
			 ; START/STOP		529 0050 10
			 ; 2x		532 0234 10
			A/C		532 0566 10
			 ;  OM 642.992		534 0183 10
			A/C		534 0257 10
			 ; START/STOP ;  OM 642.896 OM 642.898		534 0506 10
			 # F-239808.XX		535 0140 10
			HYDP; A/C		FB 6PK1413
			 ; A/C ; # OE 0019933696		FB 7PK1973
			 ; PTO ; A/C		FB 7PK2035
			 ; A/C		FB 7PK2045
					538 0234 10
			24x		420 0086 10
			24x		422 0056 10
			1x;  642.896 642.898; →04.15;  →41711428		558 0039 10
			1x;  642.986 642.992; →09.14;  →41633498		
1x;  642.896 642.898; →04.15;  →41711428		559 0087 10			
1x;  642.986 642.992; →09.14;  →41633498					
1x;  642.896 642.898; →04.15;  →41711428		559 0088 10			
1x;  642.986 642.992; →09.14;  →41633498					
1x		558 0040 10			
FAG	 ;  → 1.850 kg		713 6680 10		
	 96 mm		713 6680 20		
	 ;  1.850 kg →		713 6680 20		
	 96 mm		713 6681 10		
	 ;  ;  ;  BM 906.132 906.134 906.136		818 0336 10		
			818 0335 10		
			818 0447 10		
			825 0327 10		
			840 0373 10		
			840 1111 10		
419 CDI (906.653, 906.655, 906.657) OM 642.896; OM 642.992; (140kW)	03.09-		SAC		626 3026 33
					415 0304 10
					411 0147 10
					529 0050 10
			 ; START/STOP		532 0234 10
			 ; 2x		532 0566 10
			A/C		534 0183 10
					534 0257 10



			<p>SCHAEFFLER</p>	
--	--	--	--------------------------	--































MERCEDES-BENZ

Sprinter (906) 3-t - 5-t

























419 CDI (906.653, 906.655, 906.657)
 OM 642.896; OM 642.992;
 (140kW)

03.09-



№# F-239808.XX		535 0140 10
HYDP; A/C		FB 6PK1413
 ; A/C; # OE 0019933696		FB 7PK1973
 ; PTO; A/C		FB 7PK2035
 ; A/C		FB 7PK2045
		538 0234 10
24x		420 0086 10
 12 mm		
24x		422 0056 10
1x;  642.896; →04.15;  →41711428		558 0039 10
1x;  642.992; →09.14;  →41633498		559 0087 10
1x;  642.896; →04.15;  →41711428		559 0088 10
1x;  642.992; →09.14;  →41633498		559 0088 10
1x;  642.896; →04.15;  →41633498		559 0088 10
1x;  642.992; →09.14;  →41633498		559 0088 10
1x		558 0040 10













 ;  → 1.850 kg		713 6680 10
 96 mm		
 ;  1.850 kg →		713 6680 20
 96 mm		
 ;  BM 906.132 906.134 906.136		713 6681 10
 right		818 0336 10
 left		818 0335 10
 ; 		818 0447 10
 ↔		825 0327 10
 ↔		840 0373 10
		840 1111 10





























424 (906.153, 906.155, 906.253,
 906.255)
 M 272.979; (190kW)

06.06-12.13



























G6;  NSG 400;  ID 711.660;		462 0238 10
 Z 515.401/08 Z 515.401/09		
G6;  NSG 400;  ID 711.660;  Z 515.401/06		462 0313 10
G6;  TSG 360;  ID 711.680		462 0332 10



03.07 →;  30621934 →; A/C		529 0034 10
 ; A/C		532 0108 10
 ; →03.07;  →30621933		532 0160 10
		532 0539 10
 ; A/C		532 0667 10
 ; 03.07 →;  →30621934 →		532 0866 10
 ;  MANU		533 0100 10
		534 0067 10
		FB 6PK2403
		538 0244 10
24x;  M272.979		420 0086 10
 12 mm		
24x;  M272.979		422 0055 10
1x		558 0041 10
1x		559 0093 10





 ;  → 1.850 kg		713 6680 10
 96 mm		
 ;  1.850 kg →		713 6680 20
 96 mm		
 ;  BM 906.132 906.134 906.136		713 6681 10
 right		818 0336 10
 left		818 0335 10
 ; 		818 0447 10
 ↔		825 0327 10
 ↔		840 0373 10
		840 1111 10













424 (906.655, 906.657, 906.653)
 M 272.979; (190kW)

06.06-12.13



G6;  TSG 360;  ID 711.680		462 0332 10
---	---	-------------



03.07 →;  30621934 →; A/C		529 0034 10
 ; A/C		532 0108 10
 ; →03.07;  →30621933		532 0160 10
		532 0539 10
 ; A/C		532 0667 10
 ; 03.07 →; →30621934 →		532 0866 10
; MANU		533 0100 10
		534 0067 10
		FB 6PK2403
		538 0244 10



































			SCHAEFFLER
--	---	--	-------------------

MERCEDES-BENZ

Sprinter (906) 3-t - 5-t









































































424 (906.655, 906.657, 906.653)
 M 272.979; (190kW)

06.06-12.13

	24x;  M272.979		420 0086 10	
	 12 mm			
	24x;  M272.979		422 0055 10	
	1x		558 0041 10	
	1x		559 0093 10	
	FAG	 ;  → 1.850 kg		713 6680 10
		 96 mm		
		 ;  1.850 kg →		713 6680 20
		 96 mm		
		 ;  ;  BM 906.132 906.134 906.136		713 6681 10
		 right		818 0336 10
		 left		818 0335 10
		 ; 		818 0447 10
	 ↔		825 0327 10	
 ↔		840 0373 10		
		840 1111 10		























509 CDI (906.153, 906.155, 906.253, 906.255)
 OM 646.984; (65kW)

06.06-12.09

	G6 ;  NSG 400 ;  ID 711.660;	GearBOX	462 0238 10	
	 Z 515.401/08 Z 515.401/09			
	G6 ;  NSG 400 ;  ID 711.660;  Z 515.401/06	GearBOX	462 0313 10	
	G6 ;  TSG 360 711.680	GearBOX	462 0332 10	
	incl.  ; incl.  ; SAC		600 0255 00	
	SAC		624 3247 33	
			415 0309 10	
			411 0147 10	
		 ; A/C		529 0115 10
		A/C ; 		532 0391 20
		 ; 2x		532 0160 10
		 ; OPTION		533 0017 10
				534 0481 10
		 # F-233197.XX F-559320.XX		535 0050 10
 # F-552901.XX			535 0168 10	
			544 0116 10	
 ; PTO			FB 6PK2260	
 ; A/C				
 ; PTO		FB 6PK2285		
 ; A/C				
16x		538 0224 10		
 33 mm		420 0170 10		
		428 0092 10		
		428 0184 10		
1x		553 0147 10		
1x		559 0039 10		
FAG	 right		821 0700 10	
	 left		821 0699 10	
	 ;  → 1.850 kg		713 6680 10	
	 96 mm			
	 ;  1.850 kg →		713 6680 20	
	 96 mm			
			713 6680 40	
	 right		818 0336 10	
	 left		818 0335 10	
	 ; 		818 0447 10	
 ↔		825 0327 10		
 ↔		840 0373 10		
		840 1111 10		

509 CDI (906.653, 906.655, 906.657)
 OM 646.984; (65kW)

06.06-12.09

	G6 ;  NSG 370 ;  ID 711.651	GearBOX	462 0152 10	
	G6 ;  NSG 400 ;  ID 711.660;	GearBOX	462 0238 10	
	 Z 515.401/08 Z 515.401/09			
	G6 ;  NSG 400 ;  ID 711.660;  Z 515.401/06	GearBOX	462 0313 10	
	G6 ;  TSG 360 ;  ID 711.680	GearBOX	462 0332 10	
	incl.  ; incl.  ; SAC		600 0255 00	
	SAC		624 3247 33	
			415 0309 10	
			411 0147 10	
		 ; A/C		529 0115 10
		A/C ; 		532 0391 20



			<p>SCHAEFFLER</p>
--	--	--	--------------------------























































MERCEDES-BENZ

Sprinter (906) 3-t - 5-t

509 CDI (906.653, 906.655, 906.657)
 OM 646.984; (65kW)

06.06-12.09































































 ; 2x		532 0160 10
 ; OPTION		533 0017 10
		534 0481 10
 # F-233197.XX F-559320.XX		535 0050 10
 # F-552901.XX		535 0168 10
 ; PTO		544 0116 10
 ; A/C		FB 6PK2260
 ; PTO		FB 6PK2285
 ; A/C		538 0224 10
16x		420 0170 10
 33 mm		428 0092 10
		428 0184 10
1x	 OILP	553 0147 10
1x	 KIT	559 0039 10
 right		821 0700 10
 left		821 0699 10
 ;  → 1.850 kg	 Set	713 6680 10
 96 mm	 Set	713 6680 20
 ;  1.850 kg →	 Set	713 6680 40
 96 mm	 Set	713 6680 40
 right		818 0336 10
 left		818 0335 10
 ; 		818 0447 10
 ↔		825 0327 10
 ↔		840 0373 10
		840 1111 10
		600 0291 00

510 CDI (906.153, 906.155, 906.253,
 906.255, 906.653, 906.655,
 906.657)
 OM 651.955; (70kW)

03.09-









incl. ○		624 3408 33
SAC		415 0660 10
		411 0150 10
 ; START/STOP A/C	 KIT	529 0361 10
 ; A/C		532 0108 10
 ; 		532 0570 10
 ; 		532 0608 10
		532 0671 10
		532 0672 10
 ; START/STOP		534 0337 10
 ; START/STOP		534 0444 10
 # F-233197.XX F-559320.XX		535 0050 10
 # F-552901.XX		535 0168 10
 ; START/STOP		FB 6PK2215
 ; →08.10;  →S 495102; START/STOP		538 0221 10
16x		420 0225 10
 12 mm		422 0099 10
16x		821 0700 10
 right		821 0699 10
 left		713 6680 10
 ;  → 1.850 kg	 Set	713 6680 20
 96 mm	 Set	713 6680 40
 ;  1.850 kg →	 Set	713 6680 40
 96 mm	 Set	713 6680 40
 right		818 0336 10
 left		818 0335 10
 ; 		818 0447 10
 ↔		825 0327 10
 ↔		840 0373 10
		840 1111 10

511 CDI (906.153, 906.155, 906.253,
 906.255)
 OM 646.985; (80kW)

06.06-12.09



G6 ;  NSG 400 ;  ID 711.660;	GearBOX	462 0238 10
 Z 515.401/08 Z 515.401/09		
G6 ;  NSG 400 ;  ID 711.660;  Z 515.401/06	GearBOX	462 0313 10
G6 ;  TSG 360 ; ID 711.680	GearBOX	462 0332 10





MERCEDES-BENZ

Sprinter (906) 3-t - 5-t

511 CDI (906.153, 906.155, 906.253, 906.255) OM 646.985; (80kW)	06.06-12.09	LUK	incl. ○; incl. ■■■■■; SAC		600 0255 00	
			SAC		624 3247 33	
					415 0309 10	
					411 0147 10	
				; A/C		529 0115 10
				A/C ;		532 0391 20
						532 0108 10
				; 2x		532 0160 10
				; OPTION		533 0017 10
						534 0481 10
		■# F-233197.XX F-559320.XX			535 0050 10	
		■# F-552901.XX			535 0168 10	
		; A/C			544 0116 10	
		; A/C			FB 6PK2260	
				FB 6PK2285		
				538 0224 10		
		16x		420 0170 10		
		33 mm		428 0092 10		
				428 0184 10		
		1x		553 0147 10		
		1x		559 0039 10		
		FAG	right		821 0700 10	
			left		821 0699 10	
			; → 1.850 kg		713 6680 10	
			96 mm			
; 1.850 kg →			713 6680 20			
96 mm						
			713 6680 40			
right			818 0336 10			
left			818 0335 10			
			818 0447 10			
LUK	05.16-	incl. ○		600 0291 00		
		SAC		624 3408 33		
				415 0660 10		
				411 0150 10		
			■# F-233197.XX F-559320.XX		535 0050 10	
			■# F-552901.XX		535 0168 10	
		; START/STOP		FB 6PK2215		
		16x		420 0225 10		
		12 mm				
		16x		422 0099 10		
FAG	; → 1.850 kg		713 6680 10			
	96 mm					
	; 1.850 kg →		713 6680 20			
	96 mm					
			713 6680 40			
right		818 0336 10				
left		818 0335 10				
↔		840 0373 10				
↔		840 1111 10				
LUK	06.06-12.09	G6 ; NSG 370 ; ID 711.651		GearBOX 462 0152 10		
		G6 ; NSG 400 ; ID 711.660;		GearBOX 462 0238 10		
		Z 515.401/08 Z 515.401/09				
		G6 ; NSG 400 ; ID 711.660; Z 515.401/06		GearBOX 462 0313 10		
		G6 ; TSG 360 ; ID 711.680		GearBOX 462 0332 10		
		incl. ○; incl. ■■■■■; SAC		600 0255 00		
		SAC		624 3247 33		
				415 0309 10		
				411 0147 10		
			; A/C		529 0115 10	
A/C ;			532 0391 20			
			532 0108 10			



			<p>SCHAEFFLER</p>
--	--	--	--------------------------





































MERCEDES-BENZ

Sprinter (906) 3-t - 5-t

511 CDI (906.653, 906.655, 906.657)
 OM 646.985; (80kW)

06.06-12.09









 ; 2x		532 0160 10
 ; OPTION		533 0017 10
		534 0481 10
# F-233197.XX F-559320.XX		535 0050 10
# F-552901.XX		535 0168 10
 ; A/C		544 0116 10
 ; A/C		FB 6PK2260
		538 0224 10
16x		420 0170 10
 33 mm		428 0092 10
		428 0184 10
1x		553 0147 10
1x		559 0039 10
FAG	 right	821 0700 10
	 left	821 0699 10
	 ; # → 1.850 kg	 Set
	 96 mm	713 6680 10
	 ; #, 1.850 kg →	 Set
	 96 mm	713 6680 20
		 Set
	 right	818 0336 10
	 left	818 0335 10
	 ; #	818 0447 10
	 ↔	825 0327 10
	 ↔	840 0373 10
		840 1111 10





























511 CDI 4x4 (906.155, 906.253, 906.255)
 OM 646.985; (80kW)

06.06-12.09



G6 ; # NSG 400 ; # ID 711.660 ;  Z 515.401/08 Z 515.401/09	GearBOX	462 0238 10
G6 ; # NSG 400 ; # ID 711.660 ;  Z 515.401/06	GearBOX	462 0313 10
G6 ; # TSG 360 ; # ID 711.680	GearBOX	462 0332 10
incl. ○; incl. #; SAC		600 0255 00
SAC		624 3247 33
		415 0309 10
		411 0147 10

















A/C ; A/C		532 0391 20
		532 0108 10
 ; 2x		532 0160 10
 ; OPTION		533 0017 10
		534 0481 10
# F-233197.XX F-559320.XX		535 0050 10
 ; A/C		544 0116 10
 ; A/C		FB 6PK2260
		538 0224 10
16x		420 0170 10
 33 mm		428 0092 10
		428 0184 10
FAG	 96 mm	 Set
		 Set
	 ↔	825 0327 10
	 ↔	840 0373 10
		840 1111 10

511 CDI 4x4 (906.653, 906.655, 906.657)
 OM 646.985; (80kW)

06.06-12.09



G6 ; # NSG 400 ; # ID 711.660 ;  Z 515.401/08 Z 515.401/09	GearBOX	462 0238 10
G6 ; # NSG 400 ; # ID 711.660 ;  Z 515.401/06	GearBOX	462 0313 10
G6 ; # TSG 360 ; # ID 711.680	GearBOX	462 0332 10
SAC		624 3247 33
		415 0309 10
		411 0147 10





























































































INA	A/C ; A/C		532 0391 20
			532 0108 10
	 ; 2x		532 0160 10
	 ; OPTION		533 0017 10
			534 0481 10



			SCHAEFFLER
--	---	--	-------------------

MERCEDES-BENZ

Sprinter (906) 3-t - 5-t



















































































































511 CDI 4x4 (906.653, 906.655, 906.657) OM 646.985; (80kW)	06.06-12.09		6# F-233197.XX F-559320.XX	 535 0050 10			
			A/C	 544 0116 10			
			16x	 FB 6PK2260			
			 33 mm	 538 0224 10			
				 420 0170 10			
				 428 0092 10			
				 428 0184 10			
			FAG	 713 6680 30			
			 96 mm	 713 6680 40			
				 825 0327 10			
				 840 0373 10			
				 840 1111 10			
				 600 0291 00			
			513 CDI (906.155, 906.253, 906.255) OM 651.955; OM 651.957; (95kW)	06.06-05.16		incl. 	 624 3408 33
						SAC	 415 0660 10
	 411 0150 10						
	 529 0361 10						
A/C	 532 0108 10						
	 532 0570 10						
	 532 0608 10						
	 532 0671 10						
	 532 0672 10						
START/STOP	 534 0337 10						
START/STOP	 534 0444 10						
6# F-233197.XX F-559320.XX	 535 0050 10						
6# F-552901.XX	 535 0168 10						
03.09 →; START/STOP	 FB 6PK2215						
03.09 → 08.10; →S 495102; START/STOP	 420 0225 10						
16x	 422 0099 10						
 12 mm	 713 6680 10						
FAG	 713 6680 20						
 → 1.850 kg	 713 6680 40						
 96 mm	 713 6680 40						
	 818 0447 10						
	 825 0327 10						
	 840 0373 10						
	 840 1111 10						
	 600 0255 00						
513 CDI (906.155, 906.253, 906.255, 906.653, 906.655, 906.657) OM 646.986; (95kW)	06.06-		SA 522609 08 incl.  ; incl.  ; SAC	 600 0260 00			
			SA 522609 11 incl.  ; incl.  ; SAC	 624 3247 33			
			SAC	 415 0309 10			
				 411 0147 10			
				 411 0160 10			
				 532 0391 20			
			A/C; A/C	 532 0160 10			
			2x	 533 0017 10			
			OPTION	 534 0481 10			
				 535 0050 10			
			6# F-233197.XX F-559320.XX	 535 0168 10			
			6# F-552901.XX	 544 0116 10			
			A/C	 FB 6PK2260			
				 538 0224 10			
			16x	 420 0170 10			
			 33 mm	 428 0092 10			
				428 0184 10			
				821 0700 10			
			FAG	821 0699 10			
			right	713 6680 10			
			left				
			→ 1.850 kg				
			96 mm				



			SCHAEFFLER
--	--	--	-------------------

MERCEDES-BENZ





































































































































Sprinter (906) 3-t - 5-t

513 CDI (906.155, 906.253, 906.255, 906.653, 906.655, 906.657) OM 646.986; (95kW)	06.06-	FAG	 ;  1.850 kg →	 Set	713 6680 20
			 96 mm	 Set	713 6680 40
			 right	 Set	818 0336 10
			 left	 Set	818 0335 10
			 ; 	 Set	818 0447 10
			 ↔	 Set	825 0327 10
			 ↔	 Set	840 0373 10
				 Set	840 1111 10
				 Set	600 0291 00
			incl. 	 Set	624 3408 33
			SAC	 Set	415 0660 10
				 Set	411 0150 10
			 ; START/STOP A/C	 Set	529 0361 10
			 ; A/C	 Set	532 0108 10
			 ; 	 Set	532 0570 10
	 Set	532 0608 10			
	 Set	532 0671 10			
	 Set	532 0672 10			
 ; START/STOP	 Set	534 0337 10			
 ; START/STOP	 Set	534 0444 10			
 # F-233197.XX F-559320.XX	 Set	535 0050 10			
 ; 03.09 →; START/STOP	 Set	FB 6PK2215			
 ; 03.09 → 08.10;  → S 495102; START/STOP	 Set	420 0225 10			
16x	 Set	422 0099 10			
 12 mm	 Set	713 6680 10			
16x	 Set	713 6680 20			
 ;  → 1.850 kg	 Set	713 6680 40			
 96 mm	 Set	818 0447 10			
 ;  1.850 kg →	 Set	825 0327 10			
 96 mm	 Set	840 0373 10			
	 Set	840 1111 10			
	 Set	600 0291 00			
incl. 	 Set	624 3408 33			
SAC	 Set	415 0660 10			
	 Set	411 0150 10			
 ; START/STOP A/C	 Set	529 0361 10			
	 Set	532 0108 10			
 ; 	 Set	532 0570 10			
	 Set	532 0608 10			
	 Set	532 0671 10			
	 Set	532 0672 10			
 ; START/STOP	 Set	534 0337 10			
 ; START/STOP	 Set	534 0444 10			
 # F-233197.XX F-559320.XX	 Set	535 0050 10			
 # F-552901.XX	 Set	535 0168 10			
 ; START/STOP	 Set	FB 6PK2215			
16x	 Set	420 0225 10			
 12 mm	 Set	422 0099 10			
16x	 Set	713 6680 30			
 96 mm	 Set	713 6680 40			
 ↔	 Set	825 0327 10			
 ↔	 Set	840 0373 10			
	 Set	840 1111 10			
	 Set	600 0291 00			
incl. 	 Set	624 3408 33			
SAC	 Set	415 0660 10			
	 Set	415 0660 10			



			SCHAEFFLER
--	---	--	-------------------

MERCEDES-BENZ

Sprinter (906) 3-t - 5-t								
513 CDI 4x4 (906.653, 906.655, 906.657) OM 651.955; OM 651.957; (95kW)	06.06-	  FAG	 —	 411 0150 10				
			 ; START/STOP A/C	 529 0361 10				
			 ; A/C	 532 0108 10				
			 ; 	 532 0570 10				
			 ; 	 532 0608 10				
				 532 0671 10				
				 532 0672 10				
			 ; START/STOP	 534 0337 10				
			 ; START/STOP	 534 0444 10				
			 # F-233197.XX F-559320.XX	 535 0050 10				
			 ; 03.09 → ; START/STOP	 FB 6PK2215				
			 ; 03.09 → 08.10;  → S 495102; START/STOP					
			16x  12 mm	 420 0225 10				
			16x	 422 0099 10				
			  96 mm	  713 6680 30				
	  713 6680 40							
 ↔	 825 0327 10							
 ↔	 840 0373 10							
	 840 1111 10							
514 CDI (906.153, 906.155, 906.253, 906.255, 906.653, 906.655, 906.657) OM 651.955; (105kW)	05.16-	  FAG	 — incl.  	 600 0291 00				
			SAC	 624 3408 33				
				 415 0660 10				
			 —	 411 0150 10				
			 # F-233197.XX F-559320.XX	 535 0050 10				
			 # F-552901.XX	 535 0168 10				
			 ; START/STOP	 FB 6PK2215				
			16x  12 mm	 420 0225 10				
			16x	 422 0099 10				
			 ;  → 1.850 kg	  713 6680 10				
			 96 mm					
			 ;  1.850 kg →	  713 6680 20				
			 96 mm					
				  713 6680 40				
			 right	 818 0336 10				
 left	 818 0335 10							
 ↔	 840 0373 10							
	 840 1111 10							
514 CDI 4x4 (906.153, 906.155, 906.253, 906.255, 906.653, 906.655, 906.657) OM 651.955; (105kW)	05.16-	  FAG	 — incl.  	 600 0291 00				
			SAC	 624 3408 33				
				 415 0660 10				
			 —	 411 0150 10				
			 # F-233197.XX F-559320.XX	 535 0050 10				
			 # F-552901.XX	 535 0168 10				
			 ; START/STOP	 FB 6PK2215				
			16x  12 mm	 420 0225 10				
			16x	 422 0099 10				
			  96 mm	  713 6680 30				
				  713 6680 40				
			 ↔	 840 0373 10				
			 ↔	 840 1111 10				
			515 CDI (906.153, 906.155, 906.253, 906.255) OM 646.986; OM 646.989; OM 646.990; (110kW)	06.06-12.09		 6 ;  NSG 400 ;  ID 711.660;  Z 515.401/08 Z 515.401/09	 GearBOX 462 0238 10	
						 6 ;  NSG 400 ;  ID 711.660;  Z 515.401/06	 GearBOX 462 0313 10	
 6 ;  TSG 360 ;  ID 711.680	 GearBOX 462 0332 10							
 SA 522609 08 SA 522609 09	 600 0255 00							
incl.  ; ; SAC								
OM 646.986; SA 522609 11	600 0260 00							
incl. ; ; SAC								
SAC	624 3247 33							



			<p>SCHAEFFLER</p>
--	---	--	--------------------------

MERCEDES-BENZ

Sprinter (906) 3-t - 5-t

515 CDI (906.153, 906.155, 906.253, 906.255)

OM 646.986; OM 646.989; OM 646.990; (110kW)

06.06-12.09



SA 522609 08 SA 522609 09	415 0309 10
OM 646.986; SA 522609 11	411 0147 10
A/C ; A/C	411 0160 10
; 2x	532 0391 20
; OPTION	532 0160 10
;	533 0017 10
;	534 0481 10
; # F-233197.XX F-559320.XX	535 0050 10
; # F-552901.XX	535 0168 10
; A/C	544 0116 10
;	FB 6PK2260
;	538 0224 10
16x	420 0170 10
; 33 mm	428 0092 10
;	428 0184 10
1x	553 0147 10
1x	559 0039 10



; right	821 0700 10
; left	821 0699 10
; ; → 1.850 kg	713 6680 10
; 96 mm	713 6680 20
; ; 1.850 kg →	713 6680 40
; 96 mm	818 0336 10
; right	818 0335 10
; left	818 0447 10
; ;	825 0327 10
; ↔	840 0373 10
; ↔	840 1111 10

515 CDI (906.653, 906.655, 906.657)

OM 646.986; OM 646.989; OM 646.990; (110kW)

06.06-12.09



G6 ; NSG 370 ; ID 711.651	GearBOX 462 0152 10
G6 ; NSG 400 ; ID 711.660;	GearBOX 462 0238 10
; Z 515.401/08 Z 515.401/09	GearBOX 462 0313 10
G6 ; NSG 400 ; ID 711.660; Z 515.401/06	GearBOX 462 0332 10
G6 ; TSG 360 ; ID 711.680	600 0255 00
SA 522609 08 SA 522609 09	600 0260 00
incl. ; incl. ; SAC	624 3247 33
OM 646.986; SA 522609 11	415 0309 10
incl. ; incl. ; SAC	411 0147 10
SAC	411 0160 10
SA 522609 08 SA 522609 09	532 0391 20
OM 646.986; SA 522609 11	532 0160 10



A/C ; A/C	533 0017 10
; 2x	534 0481 10
; OPTION	535 0050 10
;	535 0168 10
; # F-233197.XX F-559320.XX	544 0116 10
; # F-552901.XX	FB 6PK2260
; A/C	FB 6PK2285
; 2x ;	FB 13X975
; ; BM =2ND ACC	538 0224 10
A/C	420 0170 10
16x	428 0092 10
; 33 mm	428 0184 10
;	553 0147 10
1x	559 0039 10
1x	821 0700 10





































































































































































































; right	821 0699 10
; left	713 6680 10
; ; → 1.850 kg	713 6680 20
; 96 mm	
; ; 1.850 kg →	
; 96 mm	



			SCHAEFFLER
--	--	--	-------------------

MERCEDES-BENZ

Sprinter (906) 3-t - 5-t																																																																																																																																																																																																																																							
515 CDI (906.653, 906.655, 906.657) OM 646.986; OM 646.989; OM 646.990; (110kW)	06.06-12.09	FAG	<table border="1"> <tr><td></td><td>Set</td><td>713 6680 40</td></tr> <tr><td></td><td>right</td><td>818 0336 10</td></tr> <tr><td></td><td>left</td><td>818 0335 10</td></tr> <tr><td></td><td></td><td>818 0447 10</td></tr> <tr><td></td><td>↔</td><td>825 0327 10</td></tr> <tr><td></td><td>↔</td><td>840 0373 10</td></tr> <tr><td></td><td></td><td>840 1111 10</td></tr> <tr><td></td><td>GearBOX</td><td>462 0238 10</td></tr> </table>		Set	713 6680 40		right	818 0336 10		left	818 0335 10			818 0447 10		↔	825 0327 10		↔	840 0373 10			840 1111 10		GearBOX	462 0238 10																																																																																																																																																																																																												
	Set	713 6680 40																																																																																																																																																																																																																																					
	right	818 0336 10																																																																																																																																																																																																																																					
	left	818 0335 10																																																																																																																																																																																																																																					
		818 0447 10																																																																																																																																																																																																																																					
	↔	825 0327 10																																																																																																																																																																																																																																					
	↔	840 0373 10																																																																																																																																																																																																																																					
		840 1111 10																																																																																																																																																																																																																																					
	GearBOX	462 0238 10																																																																																																																																																																																																																																					
515 CDI 4x4 (906.153, 906.155, 906.253, 906.255, 906.653, 906.655, 906.657) OM 646.986; OM 646.989; OM 646.990; (110kW)	06.06-12.09	LUK	<table border="1"> <tr><td></td><td>G6; NSG 400; ID 711.660; Z 515.401/08 Z 515.401/09</td><td>GearBOX</td><td>462 0313 10</td></tr> <tr><td></td><td>G6; NSG 400; ID 711.660; Z 515.401/06</td><td>GearBOX</td><td>462 0332 10</td></tr> <tr><td></td><td>G6; TSG 360; ID 711.680</td><td>GearBOX</td><td>462 0332 10</td></tr> <tr><td></td><td>SA 522609 08 SA 522609 09 incl. O; incl. SAC</td><td></td><td>600 0255 00</td></tr> <tr><td></td><td>OM 646.986; SA 522609 11 incl. O; incl. SAC</td><td></td><td>600 0260 00</td></tr> <tr><td></td><td>SAC</td><td></td><td>624 3247 33</td></tr> <tr><td></td><td></td><td></td><td>415 0309 10</td></tr> <tr><td></td><td>SA 522609 08 SA 522609 09 OM 646.986; SA 522609 11</td><td></td><td>411 0147 10</td></tr> <tr><td></td><td></td><td></td><td>411 0160 10</td></tr> <tr><td></td><td>A/C; 2x</td><td></td><td>532 0391 20</td></tr> <tr><td></td><td>OPTION</td><td></td><td>532 0160 10</td></tr> <tr><td></td><td></td><td></td><td>533 0017 10</td></tr> <tr><td></td><td>F-233197.XX F-559320.XX</td><td></td><td>534 0481 10</td></tr> <tr><td></td><td></td><td></td><td>535 0050 10</td></tr> <tr><td></td><td>A/C</td><td></td><td>544 0116 10</td></tr> <tr><td></td><td></td><td></td><td>FB 6PK2260</td></tr> <tr><td></td><td></td><td></td><td>538 0224 10</td></tr> <tr><td></td><td>16x 33 mm</td><td></td><td>420 0170 10</td></tr> <tr><td></td><td></td><td></td><td>428 0092 10</td></tr> <tr><td></td><td></td><td></td><td>428 0184 10</td></tr> <tr><td style="vertical-align: top;">FAG</td><td></td><td>Set</td><td>713 6680 30</td></tr> <tr><td></td><td></td><td>96 mm</td><td></td></tr> <tr><td></td><td></td><td>Set</td><td>713 6680 40</td></tr> <tr><td></td><td></td><td>↔</td><td>825 0327 10</td></tr> <tr><td></td><td></td><td>↔</td><td>840 0373 10</td></tr> <tr><td></td><td></td><td></td><td>840 1111 10</td></tr> <tr><td></td><td></td><td></td><td>624 3247 33</td></tr> <tr><td></td><td></td><td></td><td>411 0148 10</td></tr> <tr><td></td><td></td><td></td><td>532 0401 30</td></tr> <tr><td></td><td></td><td></td><td>532 0648 10</td></tr> <tr><td></td><td></td><td></td><td>→03.09; →31216219</td></tr> <tr><td></td><td></td><td></td><td>03.09→; →31216220→</td></tr> <tr><td></td><td></td><td></td><td>F-232001.XX</td></tr> <tr><td></td><td></td><td></td><td>F-557311.XX</td></tr> <tr><td></td><td></td><td></td><td>16x; →31216220→</td></tr> <tr><td></td><td></td><td></td><td>12 mm</td></tr> <tr><td></td><td></td><td></td><td>16x; →31216219</td></tr> <tr><td></td><td></td><td></td><td>12 mm</td></tr> <tr><td></td><td></td><td></td><td>16x; →31216220→</td></tr> <tr><td></td><td></td><td></td><td>1x; BS</td></tr> <tr><td></td><td></td><td></td><td>1x; BS</td></tr> <tr><td style="vertical-align: top;">FAG</td><td></td><td>→ 1.850 kg</td><td></td></tr> <tr><td></td><td></td><td>96 mm</td><td></td></tr> <tr><td></td><td></td><td>1.850 kg →</td><td></td></tr> <tr><td></td><td></td><td>96 mm</td><td></td></tr> <tr><td></td><td></td><td>Set</td><td>713 6680 10</td></tr> <tr><td></td><td></td><td>Set</td><td>713 6680 40</td></tr> <tr><td></td><td></td><td>right</td><td>818 0336 10</td></tr> <tr><td></td><td></td><td>left</td><td>818 0335 10</td></tr> <tr><td></td><td></td><td></td><td>818 0447 10</td></tr> <tr><td></td><td></td><td>↔</td><td>825 0327 10</td></tr> <tr><td></td><td></td><td>↔</td><td>840 0373 10</td></tr> <tr><td></td><td></td><td></td><td>840 1111 10</td></tr> <tr><td></td><td></td><td></td><td>600 0291 00</td></tr> <tr><td></td><td></td><td></td><td>incl. O</td></tr> <tr><td></td><td></td><td>SAC</td><td>624 3408 33</td></tr> <tr><td></td><td></td><td></td><td>415 0660 10</td></tr> </table>		G6; NSG 400; ID 711.660; Z 515.401/08 Z 515.401/09	GearBOX	462 0313 10		G6; NSG 400; ID 711.660; Z 515.401/06	GearBOX	462 0332 10		G6; TSG 360; ID 711.680	GearBOX	462 0332 10		SA 522609 08 SA 522609 09 incl. O; incl. SAC		600 0255 00		OM 646.986; SA 522609 11 incl. O; incl. SAC		600 0260 00		SAC		624 3247 33				415 0309 10		SA 522609 08 SA 522609 09 OM 646.986; SA 522609 11		411 0147 10				411 0160 10		A/C; 2x		532 0391 20		OPTION		532 0160 10				533 0017 10		F-233197.XX F-559320.XX		534 0481 10				535 0050 10		A/C		544 0116 10				FB 6PK2260				538 0224 10		16x 33 mm		420 0170 10				428 0092 10				428 0184 10	FAG		Set	713 6680 30			96 mm				Set	713 6680 40			↔	825 0327 10			↔	840 0373 10				840 1111 10				624 3247 33				411 0148 10				532 0401 30				532 0648 10				→03.09; →31216219				03.09→; →31216220→				F-232001.XX				F-557311.XX				16x; →31216220→				12 mm				16x; →31216219				12 mm				16x; →31216220→				1x; BS				1x; BS	FAG		→ 1.850 kg				96 mm				1.850 kg →				96 mm				Set	713 6680 10			Set	713 6680 40			right	818 0336 10			left	818 0335 10				818 0447 10			↔	825 0327 10			↔	840 0373 10				840 1111 10				600 0291 00				incl. O			SAC	624 3408 33				415 0660 10
	G6; NSG 400; ID 711.660; Z 515.401/08 Z 515.401/09	GearBOX	462 0313 10																																																																																																																																																																																																																																				
	G6; NSG 400; ID 711.660; Z 515.401/06	GearBOX	462 0332 10																																																																																																																																																																																																																																				
	G6; TSG 360; ID 711.680	GearBOX	462 0332 10																																																																																																																																																																																																																																				
	SA 522609 08 SA 522609 09 incl. O; incl. SAC		600 0255 00																																																																																																																																																																																																																																				
	OM 646.986; SA 522609 11 incl. O; incl. SAC		600 0260 00																																																																																																																																																																																																																																				
	SAC		624 3247 33																																																																																																																																																																																																																																				
			415 0309 10																																																																																																																																																																																																																																				
	SA 522609 08 SA 522609 09 OM 646.986; SA 522609 11		411 0147 10																																																																																																																																																																																																																																				
			411 0160 10																																																																																																																																																																																																																																				
	A/C; 2x		532 0391 20																																																																																																																																																																																																																																				
	OPTION		532 0160 10																																																																																																																																																																																																																																				
			533 0017 10																																																																																																																																																																																																																																				
	F-233197.XX F-559320.XX		534 0481 10																																																																																																																																																																																																																																				
			535 0050 10																																																																																																																																																																																																																																				
	A/C		544 0116 10																																																																																																																																																																																																																																				
			FB 6PK2260																																																																																																																																																																																																																																				
			538 0224 10																																																																																																																																																																																																																																				
	16x 33 mm		420 0170 10																																																																																																																																																																																																																																				
			428 0092 10																																																																																																																																																																																																																																				
			428 0184 10																																																																																																																																																																																																																																				
FAG		Set	713 6680 30																																																																																																																																																																																																																																				
		96 mm																																																																																																																																																																																																																																					
		Set	713 6680 40																																																																																																																																																																																																																																				
		↔	825 0327 10																																																																																																																																																																																																																																				
		↔	840 0373 10																																																																																																																																																																																																																																				
			840 1111 10																																																																																																																																																																																																																																				
			624 3247 33																																																																																																																																																																																																																																				
			411 0148 10																																																																																																																																																																																																																																				
			532 0401 30																																																																																																																																																																																																																																				
			532 0648 10																																																																																																																																																																																																																																				
			→03.09; →31216219																																																																																																																																																																																																																																				
			03.09→; →31216220→																																																																																																																																																																																																																																				
			F-232001.XX																																																																																																																																																																																																																																				
			F-557311.XX																																																																																																																																																																																																																																				
			16x; →31216220→																																																																																																																																																																																																																																				
			12 mm																																																																																																																																																																																																																																				
			16x; →31216219																																																																																																																																																																																																																																				
			12 mm																																																																																																																																																																																																																																				
			16x; →31216220→																																																																																																																																																																																																																																				
			1x; BS																																																																																																																																																																																																																																				
			1x; BS																																																																																																																																																																																																																																				
FAG		→ 1.850 kg																																																																																																																																																																																																																																					
		96 mm																																																																																																																																																																																																																																					
		1.850 kg →																																																																																																																																																																																																																																					
		96 mm																																																																																																																																																																																																																																					
		Set	713 6680 10																																																																																																																																																																																																																																				
		Set	713 6680 40																																																																																																																																																																																																																																				
		right	818 0336 10																																																																																																																																																																																																																																				
		left	818 0335 10																																																																																																																																																																																																																																				
			818 0447 10																																																																																																																																																																																																																																				
		↔	825 0327 10																																																																																																																																																																																																																																				
		↔	840 0373 10																																																																																																																																																																																																																																				
			840 1111 10																																																																																																																																																																																																																																				
			600 0291 00																																																																																																																																																																																																																																				
			incl. O																																																																																																																																																																																																																																				
		SAC	624 3408 33																																																																																																																																																																																																																																				
			415 0660 10																																																																																																																																																																																																																																				



			SCHAEFFLER
--	---	--	-------------------

MERCEDES-BENZ

Sprinter (906) 3-t - 5-t

516 CDI (906.153, 906.155, 906.253, 906.255)

OM 651.955; OM 651.957; (120kW)

03.09-



411 0150 10



START/STOP A/C



529 0361 10

A/C



532 0108 10

START/STOP



532 0570 10

START/STOP



532 0608 10

START/STOP



532 0671 10

START/STOP



532 0672 10

START/STOP



534 0337 10

START/STOP



534 0444 10

F-233197.XX F-559320.XX



535 0050 10

START/STOP



FB 6PK2215

→08.10; →S 495102; START/STOP



538 0221 10

16x



420 0225 10

12 mm

16x



422 0099 10

FAG

right



821 0700 10

left



821 0699 10

→ 1.850 kg



713 6680 10

96 mm



713 6680 20

→ 1.850 kg →



713 6680 40

96 mm



818 0336 10

right



818 0335 10

left



818 0447 10

↔



825 0327 10

↔



840 0373 10

840 1111 10



600 0291 00

516 CDI (906.653, 906.655, 906.657)

OM 651.955; OM 651.957; (120kW)

03.09-



S559085 →; incl. SAC



624 3408 33

SAC



415 0660 10

START/STOP A/C



411 0150 10

A/C



529 0361 10

START/STOP



532 0108 10

START/STOP



532 0570 10

START/STOP



532 0608 10

START/STOP



532 0671 10

START/STOP



532 0672 10

START/STOP



534 0337 10

START/STOP



534 0444 10

F-233197.XX F-559320.XX



535 0050 10

START/STOP



FB 6PK2215

→08.10; →S 495102; START/STOP



538 0221 10

16x



420 0225 10

12 mm

16x



422 0099 10

FAG

right



821 0700 10

left



821 0699 10

→ 1.850 kg



713 6680 10

96 mm



713 6680 20

→ 1.850 kg →



713 6680 40

96 mm



818 0336 10

right



818 0335 10

left



818 0447 10

↔



825 0327 10

↔



840 0373 10

840 1111 10



600 0291 00

516 CDI 4x4 (906.153, 906.155, 906.255)

OM 651.955; OM 651.957; (120kW)

05.11-



S559085 →; incl. SAC



624 3408 33

SAC



415 0660 10

START/STOP A/C





























































































































411 0150 10



			SCHAEFFLER
--	---	--	-------------------

MERCEDES-BENZ

Sprinter (906) 3-t - 5-t































































































516 CDI 4x4 (906.153, 906.155, 906.255) OM 651.955; OM 651.957; (120kW)	05.11-		 ; START/STOP A/C	 529 0361 10			
			 ; A/C	 532 0108 10			
			 ; 	 532 0570 10			
				 532 0608 10			
				 532 0671 10			
				 532 0672 10			
			 ; START/STOP	 534 0337 10			
			 ; START/STOP	 534 0444 10			
			 # F-233197.XX F-559320.XX	 535 0050 10			
			 # F-552901.XX	 535 0168 10			
			 ; START/STOP	 FB 6PK2215			
			16x	 420 0225 10			
			 12 mm				
			16x	 422 0099 10			
			FAG	 	 Set 713 6680 30		
				 96 mm			
					 Set 713 6680 40		
				 ↔	 825 0327 10		
				 ↔	 840 0373 10		
					 840 1111 10		
516 CDI 4x4 (906.653, 906.655, 906.657) OM 651.955; OM 651.957; (120kW)	06.06-		 incl. 	 600 0291 00			
			SAC	 624 3408 33			
				 415 0660 10			
				 411 0150 10			
				 ; START/STOP A/C	 529 0361 10		
				 ; A/C	 532 0108 10		
				 ; 	 532 0570 10		
					 532 0608 10		
					 532 0671 10		
					 532 0672 10		
				 ; START/STOP	 534 0337 10		
				 ; START/STOP	 534 0444 10		
				 # F-233197.XX F-559320.XX	 535 0050 10		
				 ; 03.09 → ; START/STOP	 FB 6PK2215		
				 ; 03.09 → 08.10 ;  → S 495102 ; START/STOP			
				16x	 420 0225 10		
				 12 mm			
				16x	 422 0099 10		
				FAG	 	 Set 713 6680 30	
					 96 mm		
	 Set 713 6680 40						
 ↔	 825 0327 10						
 ↔	 840 0373 10						
	 840 1111 10						
516 NGT (906.153, 906.155, 906.253, 906.255) M 271.951; (115kW)	09.08-		SAC	 624 3247 33			
				 411 0148 10			
					 532 0401 30		
					 532 0648 10		
				 ; → 03.09 ;  → 31216219	 534 0081 30		
				 ; 03.09 → ;  31216220 →	 534 0370 10		
				 # F-232001.XX	 535 0042 10		
				 # F-557311.XX	 535 0165 10		
				16x ;  31216220 →	 420 0086 10		
				 12 mm			
				16x ;  → 31216219	 420 0218 10		
				 12 mm			
				16x ;  31216220 →	 422 0144 10		
				1x ;  BS	 KIT 559 0045 10		
				1x ;  BS	 KIT 559 0051 10		
				FAG	 ;  → 1.850 kg	 Set 713 6680 10	
					 96 mm		
					 ;  1.850 kg →	 Set 713 6680 20	
					96 mm		
						Set 713 6680 40	
right	818 0336 10						
left	818 0335 10						



			<p>SCHAEFFLER</p>
--	---	--	--------------------------

MERCEDES-BENZ

Sprinter (906) 3-t - 5-t





























































































<p>516 NGT (906.153, 906.155, 906.253, 906.255) M 271.951; (115kW)</p>	<p>09.08-</p>	<p>FAG</p>	<p>;   ↔  ↔</p>	<p> 818 0447 10  825 0327 10  840 0373 10  840 1111 10</p>
<p>518 CDI (906.153, 906.155, 906.253, 906.255) OM 642.896; OM 642.986; OM 642.992; OM 642.993; (135kW)</p>	<p>06.06-12.09</p>	<p>LUK</p>	<p>G6; NSG 400; ID 711.660;  Z 515.401/08 Z 515.401/09 G6; NSG 400; ID 711.660;  Z 515.401/06 SAC  ; 2x A/C ;  OM 642.992 OM 642.993 A/C ; START/STOP;  OM 642.896  # F-233197.XX F-559320.XX  # F-239808.XX HYDP; A/C ; A/C; # OE 0019933696 ; ; A/C ; A/C 24x  12 mm 24x 1x 1x 1x 1x 1x 1x</p>	<p>GearBOX 462 0238 10 GearBOX 462 0313 10  626 3026 33  415 0304 10  411 0147 10  532 0234 10  532 0566 10  534 0183 10  534 0257 10  534 0506 10  535 0050 10  535 0140 10  FB 6PK1413  FB 7PK1973  FB 7PK2035  FB 7PK2045  538 0234 10  420 0086 10  422 0056 10  558 0039 10  559 0049 10  559 0050 10  559 0087 10  559 0088 10  558 0040 10</p>
<p>518 CDI (906.653, 906.655, 906.657) OM 642.896; OM 642.986; OM 642.992; OM 642.993; (135kW)</p>	<p>06.06-12.09</p>	<p>LUK</p>	<p>FAG right left ;  → 1.850 kg  96 mm ;  1.850 kg →  96 mm  ; 2x right left ;   ↔  ↔ G6; NSG 370; ID 711.651 G6; NSG 400; ID 711.660;  Z 515.401/08 Z 515.401/09 G6; NSG 400; ID 711.660;  Z 515.401/06 G6; TSG 360; ID 711.680 SAC  626 3026 33  415 0304 10  411 0147 10  532 0234 10  532 0566 10  534 0183 10  534 0257 10  534 0506 10  535 0050 10  535 0140 10  FB 6PK1413  FB 7PK1973  FB 7PK2035  FB 7PK2045  538 0234 10  420 0086 10 24x  12 mm 24x 1x</p>	<p>GearBOX 462 0152 10 GearBOX 462 0238 10 GearBOX 462 0313 10 GearBOX 462 0332 10  626 3026 33  415 0304 10  411 0147 10  532 0234 10  532 0566 10  534 0183 10  534 0257 10  534 0506 10  535 0050 10  535 0140 10  FB 6PK1413  FB 7PK1973  FB 7PK2035  FB 7PK2045  538 0234 10  420 0086 10  422 0056 10  558 0039 10</p>



			SCHAEFFLER
--	---	--	-------------------

MERCEDES-BENZ

Sprinter (906) 3-t - 5-t













































518 CDI (906.653, 906.655, 906.657) OM 642.896; OM 642.986; OM 642.992; OM 642.993; (135kW)	06.06-12.09	 FAG	1x	 559 0049 10
			1x	 559 0050 10
			1x	 559 0087 10
			1x	 559 0088 10
			1x	 558 0040 10
			 right	 821 0700 10
			 left	 821 0699 10
			  → 1.850 kg	 713 6680 10
			 96 mm	
			  1.850 kg →	 713 6680 20
			 96 mm	
			 	 713 6680 40
			 right	 818 0336 10
			 left	 818 0335 10
			 	 818 0447 10
 ↔	 825 0327 10			
 ↔	 840 0373 10			
	 840 1111 10			
518 CDI 4x4 (906.153, 906.155, 906.253, 906.255) OM 642.896; OM 642.986; OM 642.992; OM 642.993; (135kW)	06.06-12.09	 LUK	G6 ;  NSG 400 ;  ID 711.660;	GearBOX 462 0238 10
			 Z 515.401/08 Z 515.401/09	
			G6 ;  NSG 400 ;  ID 711.660;  Z 515.401/06	GearBOX 462 0313 10
			G6 ;  TSG 360 ;  ID 711.680	GearBOX 462 0332 10
			SAC	 626 3026 33
				 415 0304 10
				 411 0147 10
			 ; START/STOP	 529 0050 10
			 ; 2x	 532 0234 10
			A/C	 532 0566 10
			 OM 642.992 OM 642.993	 534 0183 10
			A/C	 534 0257 10
			 ; START/STOP ;  OM 642.896	 534 0506 10
			 # F-233197.XX F-559320.XX	 535 0050 10
			 # F-239808.XX	 535 0140 10
HYDP; A/C	 FB 6PK1413			
 ;  # OE 0019933696	 FB 7PK1973			
 ; A/C	 FB 7PK2035			
 ; A/C	 FB 7PK2045			
	 538 0234 10			
24x	 420 0086 10			
 12 mm				
24x	 422 0056 10			
1x	 558 0039 10			
1x	 559 0049 10			
1x	 559 0050 10			
1x	 559 0087 10			
1x	 559 0088 10			
1x	 558 0040 10			
	713 6680 30			
96 mm				
	713 6680 40			
↔	825 0327 10			
↔	840 0373 10			
	840 1111 10			
518 CDI 4x4 (906.653, 906.655, 906.657) OM 642.896; OM 642.986; OM 642.992; OM 642.993; (135kW)	06.06-12.09	 LUK	G6 ;  NSG 400 ;  ID 711.660;	GearBOX 462 0238 10
			 Z 515.401/08 Z 515.401/09	
			G6 ;  NSG 400 ;  ID 711.660;  Z 515.401/06	GearBOX 462 0313 10
			G6 ;  TSG 360 ;  ID 711.680	GearBOX 462 0332 10
			SAC	 626 3026 33
				 415 0304 10
				 411 0147 10
			 ; START/STOP	529 0050 10
			; 2x	532 0234 10
			A/C	532 0566 10
			OM 642.992 OM 642.993	534 0183 10
			A/C	534 0257 10
			; START/STOP ; OM 642.896	534 0506 10
			# F-233197.XX F-559320.XX	535 0050 10
			# F-239808.XX	535 0140 10
HYDP; A/C	FB 6PK1413			



			SCHAEFFLER
--	---	--	-------------------

MERCEDES-BENZ

Sprinter (906) 3-t - 5-t

518 CDI 4x4 (906.653, 906.655, 906.657) OM 642.896; OM 642.986; OM 642.992; OM 642.993; (135kW)	06.06-12.09		A/C; # OE 0019933696  FB 7PK1973
			PTO; A/C  FB 7PK2035
519 CDI / BlueTEC (906.153, 906.155, 906.253, 906.255) OM 642.896; OM 642.898; OM 642.986; OM 642.992; (140kW)	03.09-		SAC  626 3026 33 OM 642.896  415 0304 10 OM 642.992 OM 642.993
			START/STOP  411 0147 10 2x  529 0050 10 A/C  532 0234 10 OM 642.992  532 0566 10 A/C  534 0183 10 START/STOP; OM 642.896 OM 642.898  534 0257 10 # F-239808.XX  534 0506 10 HYDP; A/C  535 0140 10 A/C; # OE 0019933696  FB 6PK1413 PTO; A/C  FB 7PK1973 A/C  FB 7PK2035 A/C  FB 7PK2045 538 0234 10 420 0086 10 24x  422 0056 10 12 mm  558 0039 10 24x  559 0049 10 1x; OM 642.896 642.898; →04.15; →41711428  559 0050 10 1x; OM 642.986 642.992; →09.14; →41633498  559 0087 10 1x; OM 642.896 642.898; →04.15; →41711428  559 0088 10 1x; OM 642.986 642.992; →09.14; →41633498  559 0088 10 1x; OM 642.896 642.898; →04.15; →41711428  559 0088 10 1x; OM 642.986 642.992; →09.14; →41633498  558 0040 10 1x  821 0700 10 right  821 0699 10 left  713 6680 10 1.850 kg →  713 6680 20 96 mm  713 6680 40 1.850 kg →  713 6680 40 96 mm  818 0336 10 right  818 0335 10 left  818 0447 10 →  825 0327 10 ↔  840 0373 10 ↔  840 1111 10 SAC  626 3026 33 OM 642.896  415 0304 10 OM 642.898 OM 642.992 OM 642.993
			START/STOP  411 0147 10 2x  529 0050 10 A/C  532 0234 10 A/C  532 0566 10





MERCEDES-BENZ

Sprinter (906) 3-t - 5-t

519 CDI / BlueTEC (906.653, 906.655, 906.657)
 OM 642.896; OM 642.898; OM 642.986; OM 642.992; (140kW)

03.09-



	OM 642.992		534 0183 10
	A/C		534 0257 10
	START/STOP ; OM 642.896 OM 642.898		534 0506 10
	F-239808.XX		535 0140 10
	HYDP; A/C		FB 6PK1413
	A/C ; # OE 0019933696		FB 7PK1973
	PTO ; A/C		FB 7PK2035
	A/C		FB 7PK2045
			538 0234 10
			420 0086 10
24x			
	12 mm		
24x			422 0056 10
1x; OM 642.896 642.898; →04.15; OM →41711428			558 0039 10
1x; OM 642.986 642.992; →09.14; OM →41633498			
1x; OM 642.896 642.898; →04.15; OM →41711428			559 0087 10
1x; OM 642.986 642.992; →09.14; OM →41633498			
1x; OM 642.896 642.898; →04.15; OM →41711428			559 0088 10
1x; OM 642.986 642.992; →09.14; OM →41633498			
1x			558 0040 10
FAG			
	right		821 0700 10
	left		821 0699 10
	→ 1.850 kg		713 6680 10
	96 mm		
	1.850 kg →		713 6680 20
	96 mm		
	right		713 6680 40
	left		818 0336 10
	right		818 0335 10
	left		818 0447 10
	right		825 0327 10
	left		840 0373 10
	right		840 1111 10

519 CDI / BlueTEC 4x4 (906.153, 906.155, 906.253, ...)
 OM 642.896; OM 642.898; OM 642.986; OM 642.992; (140kW)

03.09-



	SAC		626 3026 33
			415 0304 10
			411 0147 10
	START/STOP		529 0050 10
	2x		532 0234 10
	A/C		532 0566 10
	OM 642.992		534 0183 10
	A/C		534 0257 10
	START/STOP ; OM 642.896 OM 642.898		534 0506 10
	F-239808.XX		535 0140 10
	HYDP; A/C		FB 6PK1413
	A/C ; # OE 0019933696		FB 7PK1973
	PTO ; A/C		FB 7PK2035
	A/C		FB 7PK2045
			538 0234 10
			420 0086 10
24x			
	12 mm		
24x			422 0056 10
1x; OM 642.896 642.898; →04.15; OM →41711428			558 0039 10
OM 642.986 642.992; →09.14; OM →41633498			
1x			559 0049 10
1x			559 0050 10
1x; OM 642.896 642.898; →04.15; OM →41711428			559 0088 10
1x; OM 642.986 642.992; →09.14; OM →41633498			
1x			558 0040 10
FAG			
	right		713 6680 30
	96 mm		
	right		713 6680 40
	left		825 0327 10
	right		840 0373 10
	left		840 1111 10

519 CDI / BlueTEC 4x4 (906.653, 906.655, 906.657)
 OM 642.896; OM 642.898; OM 642.986; OM 642.992; (140kW)

03.09-



	SAC		626 3026 33
			415 0304 10
			411 0147 10
	START/STOP		529 0050 10
	2x		532 0234 10



			SCHAEFFLER
--	---	--	-------------------









































MERCEDES-BENZ

Sprinter (906) 3-t - 5-t







519 CDI / BlueTEC 4x4 (906.653, 906.655, 906.657)
 OM 642.896; OM 642.898; OM 642.986; OM 642.992; (140kW)

03.09-



A/C		532 0566 10
 ;  OM 642.992		534 0183 10
A/C		534 0257 10
 ; START/STOP ;  OM 642.896 OM 642.898		534 0506 10
 # F-239808.XX		535 0140 10
HYDP; A/C		FB 6PK1413
 ; A/C; # OE 0019933696		FB 7PK1973
 ; PTO; A/C		FB 7PK2035
 ; A/C		FB 7PK2045
		538 0234 10
24x		420 0086 10
 12 mm		
24x		422 0056 10
1x;  642.896 642.898; →04.15;  →41711428		558 0039 10
1x;  642.986 642.992; →09.14;  →41633498		
1x;  642.896 642.898; →04.15;  →41711428		559 0087 10
 642.986 642.992; →09.14;  →41633498		
1x;  642.896 642.898; →04.15;  →41711428		559 0088 10
1x;  642.986 642.992; →09.14;  →41633498		
1x		558 0040 10













FAG

		Set	713 6680 30
 96 mm		Set	713 6680 40
			
 ↔			825 0327 10
 ↔			840 0373 10
			840 1111 10





























524 (906.153, 906.155, 906.253, 906.255)
 M 272.979; (190kW)

06.06-12.13



























G6;  NSG 400;  ID 711.660;		GearBOX	462 0238 10
 Z 515.401/08 Z 515.401/09			
G6;  NSG 400;  ID 711.660;  Z 515.401/06		GearBOX	462 0313 10
G6;  TSG 360;  ID 711.680		GearBOX	462 0332 10



03.07 →;  30621934 →; A/C			529 0034 10
 ; A/C			532 0108 10
 ; →03.07;  →30621933			532 0160 10
			532 0539 10
 ; A/C			532 0667 10
 ; 03.07 →;  30621934 →			532 0866 10
 ;  MANU			533 0100 10
			534 0067 10
			FB 6PK2403
			538 0244 10
24x;  M272.979			420 0086 10
 12 mm			
24x;  M272.979			422 0055 10
1x			558 0041 10
1x			559 0093 10







FAG

 ;  → 1.850 kg		Set	713 6680 10
 96 mm			
 ;  1.850 kg →		Set	713 6680 20
 96 mm			
		Set	713 6680 40
 right			818 0336 10
 left			818 0335 10
 ; 			818 0447 10
 ↔			825 0327 10
 ↔			840 0373 10
			840 1111 10























524 (906.653, 906.655, 906.657)
 M 272.979; (190kW)

06.06-12.13



G6;  NSG 370;  ID 711.651		GearBOX	462 0152 10
G6;  TSG 360;  ID 711.680		GearBOX	462 0332 10



















03.07 →;  30621934 →; A/C			529 0034 10
 ; A/C			532 0108 10
 ; →03.07;  →30621933			532 0160 10
			532 0539 10
 ; A/C			532 0667 10
 ; 03.07 →;  30621934 →			532 0866 10
 ;  MANU			533 0100 10
			534 0067 10
			FB 6PK2403
			538 0244 10









			SCHAEFFLER
--	---	--	-------------------

MERCEDES-BENZ











































Sprinter (906) 3-t - 5-t

524 (906.653, 906.655, 906.657) M 272.979; (190kW)	06.06-12.13		24x; M272.979 12 mm		420 0086 10
			24x; M272.979		422 0055 10
			1x		558 0041 10
			1x		559 0093 10
		FAG	right		821 0700 10
			left		821 0699 10
			→ 1.850 kg 96 mm		713 6680 10
			1.850 kg → 96 mm		713 6680 20
					713 6680 40
			right		818 0336 10
			left		818 0335 10
					818 0447 10
			↔		825 0327 10
			↔		840 0373 10
		840 1111 10			

SPRINTER 3,5-t Kasten (907, 910)

314 CDI (910.631, 910.633) OM 651.950; OM 651.958; (105kW)	02.18-				415 0931 10
					411 0150 10
			16x 12 mm		420 0225 10
			16x		422 0099 10































































VITO (639)

109 CDI (639.601, 639.603, 639.605) OM 646.983; (65kW)	09.03-		716.637 ; N° 011089 → 716.652 incl. O; incl. 		600 0290 00	
			SAC		624 3162 09	
			716.637 ; N° →011088 SAC		624 3162 33	
			716.637 ; N° 011089 → 716.652 SAC		624 3162 34	
					415 0242 10	
					411 0147 10	
				A/C		529 0115 10
				A/C ; 		532 0391 20
						532 0108 10
				2x		532 0160 10
		OPTION			533 0017 10	
					534 0481 10	
		# F-233197.XX F-559320.XX			535 0050 10	
		# F-552901.XX			535 0168 10	
					544 0116 10	
		PTO			FB 6PK2260	
		PTO ; →158569		FB 6PK2270		
		158570 →; PTO		FB 6PK2280		
				538 0224 10		
		16x 33 mm		420 0170 10		
				428 0092 10		
				428 0184 10		
		1x		553 0147 10		
		1x		559 0039 10		
		FAG	right		821 0572 10	
			left		821 0571 10	
			3603472 →		713 0087 20	
			→3603471		713 0406 20	
					713 6680 50	
			92 mm		713 6679 80	
			→08.10; →3603472		713 6679 80	
			92 mm			
			→06.11		771 0537 30	
3603472 →			814 0178 10			
→3603471; right;		818 0306 10				
→3603471; left;		818 0307 10				
→3603471;		825 0250 10				



			<p>SCHAEFFLER</p>
--	---	--	--------------------------

























































































































MERCEDES-BENZ

VITO (639)					
109 CDI (639.601, 639.603, 639.605) OM 646.983; (65kW)	09.03-	FAG			840 0313 10
					840 1015 10
					840 1016 10
109 CDI (639.601, 639.603, 639.605) OM 646.980; OM 646.981; (70kW)	08.06-	LUK			600 0290 00
					624 3162 09
					624 3162 34
					415 0242 10
					411 0147 10
			A/C		529 0115 10
			A/C;		532 0391 20
			A/C; 2x		532 0108 10
			A/C; 2x		532 0160 10
			A/C; OPTION		533 0017 10
			A/C		534 0481 10
			F-233197.XX F-559320.XX		535 0050 10
			F-552901.XX		535 0168 10
			A/C		544 0116 10
			A/C; →158569; A/C		FB 6PK2260
			A/C; →158570		FB 6PK2285
			START/STOP		538 0224 10
			START/STOP		538 0749 10
			16x		538 0800 10
			33 mm		420 0170 10
					428 0092 10
					428 0184 10
			1x		553 0147 10
			1x		559 0039 10
		FAG			821 0572 10
					821 0571 10
					713 0087 20
					713 0406 20
					713 6680 50
					713 6679 80
					771 0537 30
					814 0178 10
					818 0306 10
					818 0307 10
					825 0250 10
					840 0313 10
					840 1015 10
					840 1016 10
109 CDI (639.701, 639.703) OM 646.980; (70kW)	09.06-	LUK			600 0290 00
					624 3162 09
					624 3162 33
					624 3162 34
					415 0242 10
					411 0147 10
			A/C;		532 0391 20
			A/C		532 0108 10
			A/C; 2x		532 0160 10
			A/C; OPTION		533 0017 10
			A/C		534 0481 10
			F-233197.XX F-559320.XX		535 0050 10
			F-552901.XX		535 0168 10
			A/C		FB 6PK2260



			SCHAEFFLER
--	---	--	-------------------

MERCEDES-BENZ

VITO (639)			
109 CDI (639.701, 639.703) OM 646.980; (70kW)	09.06-		START/STOP  538 0224 10
			START/STOP  538 0749 10
			16x  538 0800 10
			 33 mm  420 0170 10
			  428 0092 10
			  428 0184 10
			 right  821 0572 10
			 left  821 0571 10
			 ;  3603472 →  713 0087 20
			 ;  →3603471  713 0406 20
		  Set 713 6680 50	
		 92 mm  Set 713 6679 80	
		 ; →08.10;  →3603472  771 0537 30	
		 92 mm  814 0178 10	
		 ; →06.11  818 0306 10	
		 ;  3603472 →  818 0307 10	
		 →3603471;  right;   825 0250 10	
		 →3603471;  left;   840 0313 10	
		 →3603471;   840 1015 10	
		 right  840 1016 10	
 left  600 0290 00			
109 CDI (639.701) OM 646.983; (65kW)	09.03-		 716.637 ;  N° 011089 →  624 3162 09
			 716.652  624 3162 33
			incl.  ; incl.   624 3162 34
			SAC  415 0242 10
			 716.637 ;  N° →011088  411 0147 10
			SAC  529 0115 10
			 716.637 ;  N° 011089 →  532 0391 20
			 716.652  532 0108 10
			SAC  532 0160 10
			 ;  N° 011089 →  533 0017 10
		 716.652  534 0481 10	
		SAC  535 0050 10	
		 # F-233197.XX F-559320.XX  535 0168 10	
		 # F-552901.XX  544 0116 10	
		 ; PTO  FB 6PK2260	
		 ; PTO ;  →158569  FB 6PK2270	
		 ;  158570 →; PTO  FB 6PK2280	
		 538 0224 10	
		16x  420 0170 10	
		 33 mm  428 0092 10	
  428 0184 10			
1x  OILP 553 0147 10			
1x  KIT 559 0039 10			
		 right  821 0572 10	
		 left  821 0571 10	
		 ;  3603472 →  713 0087 20	
		 ;  →3603471  713 0406 20	
		  Set 713 6680 50	
		 92 mm  Set 713 6679 80	
		 ; →08.10;  →3603472  771 0537 30	
		 92 mm  814 0178 10	
		 ; →06.11  818 0306 10	
		 ;  3603472 →  818 0307 10	
→3603471; right; 825 0250 10			
→3603471; left; 840 0313 10			
→3603471; 840 1015 10			
right 840 1016 10			
left 840 1016 10			



			<p>SCHAEFFLER</p>
--	--	--	--------------------------





















































































































































MERCEDES-BENZ

VITO (639)			
<p>109 CDI 4x4 (639.701) OM 646.981; (70kW)</p>	<p>09.07-</p>	<p>LUK</p> <p>716.637 ; N° 011089 → 716.652 incl. ○; incl. ■■■■</p> <p>SAC</p> <p>716.637 ; N° 011089 → 716.652 SAC</p> <p>TINA A</p> <p>; A/C A/C ; ; 2x ; OPTION ; # F-233197.XX F-559320.XX # F-552901.XX ; A/C ; →158569; A/C ; A/C ; 158570 →</p> <p>START/STOP START/STOP 16x 33 mm</p> <p>428 0092 10 428 0184 10</p> <p>1x 1x</p> <p>FAG</p> <p>; right ; left ; 3603472 → ; →3603471 ; 92 mm ; →08.10; →3603472 92 mm ; →06.11 ; 3603472 → ; →3603471; right; ; →3603471; left; ; →3603471; right left</p>	<p>600 0290 00</p> <p>624 3162 09</p> <p>624 3162 34</p> <p>415 0242 10</p> <p>411 0147 10</p> <p>529 0115 10</p> <p>532 0391 20</p> <p>532 0108 10</p> <p>532 0160 10</p> <p>533 0017 10</p> <p>534 0481 10</p> <p>535 0050 10</p> <p>535 0168 10</p> <p>544 0116 10</p> <p>FB 6PK2260</p> <p>FB 6PK2270</p> <p>FB 6PK2285</p> <p>538 0224 10</p> <p>538 0749 10</p> <p>538 0800 10</p> <p>420 0170 10</p> <p>428 0092 10</p> <p>428 0184 10</p> <p>OILP 553 0147 10</p> <p>SKIT 559 0039 10</p> <p>821 0572 10</p> <p>821 0571 10</p> <p>713 0087 20</p> <p>713 0406 20</p> <p>Set 713 6679 80</p> <p>Set 713 6679 80</p> <p>771 0537 30</p> <p>814 0178 10</p> <p>818 0306 10</p> <p>818 0307 10</p> <p>825 0250 10</p> <p>840 0313 10</p> <p>840 1015 10</p> <p>840 1016 10</p>
<p>110 CDI (639.601, 639.603, 639.605, 639.701, 639.703, 639.705) OM 651.940; (70kW)</p>	<p>09.10-</p>	<p>LUK</p> <p>711.680 ; SA515411 04 716.637 ; N° 011089 → 716.652 incl. ○</p> <p>SAC</p> <p>711.680 ; SA515411 04 716.637 ; N° 011089 → 716.652 SAC</p> <p>TINA A</p> <p>; START/STOP A/C ; A/C ; 2x ; ; ; START/STOP ; START/STOP # F-233197.XX F-559320.XX # F-552901.XX ; →08.14; START/STOP</p>	<p>600 0291 00</p> <p>624 3408 09</p> <p>624 3408 33</p> <p>415 0660 10</p> <p>411 0150 10</p> <p>529 0361 10</p> <p>532 0108 10</p> <p>532 0160 10</p> <p>532 0570 10</p> <p>532 0671 10</p> <p>532 0672 10</p> <p>534 0337 10</p> <p>534 0444 10</p> <p>535 0050 10</p> <p>535 0168 10</p> <p>FB 6PK2215</p>



			SCHAEFFLER
--	---	--	-------------------

MERCEDES-BENZ

VITO (639)								
110 CDI (639.601, 639.603, 639.605, 639.701, 639.703, 639.705) OM 651.940; (70kW)	09.10-		16x		538 0224 10			
			 12 mm		420 0225 10			
			16x		422 0099 10			
			 ;  3603472→		713 0087 20			
			 ;  →3603471		713 0406 20			
					713 6680 50			
			 92 mm		771 0537 30			
			 ;  3603472→		814 0178 10			
			 →3603471;  right; 		818 0306 10			
			 →3603471;  left; 		818 0307 10			
			 →3603471; 		825 0250 10			
					840 0313 10			
			 right		840 1015 10			
			 left		840 1016 10			
					600 0290 00			
			111 CDI (639.601, 639.603, 639.605) OM 646.982; (80kW)	09.03-		 716.637 ;  N° 011089→		600 0290 00
						 716.652		624 3162 09
						incl.  ; incl. 		624 3162 33
SAC		624 3162 34						
 716.637 ;  N° →011088		415 0242 10						
SAC		411 0147 10						
 716.637 ;  N° 011089→		529 0115 10						
 716.652		532 0391 20						
SAC		532 0108 10						
 716.637 ;  N° 011089→		532 0160 10						
 716.652		532 0160 10						
SAC		533 0017 10						
		534 0481 10						
 ; A/C		535 0050 10						
A/C ; 		535 0168 10						
 ; A/C		544 0116 10						
 ; 2x		544 0116 10						
 ; OPTION		FB 6PK2260						
 # F-233197.XX F-559320.XX		FB 6PK2270						
 # F-552901.XX		FB 6PK2280						
 ; PTO		538 0224 10						
 ; PTO ;  →158569		420 0170 10						
 ;  158570→ ; PTO		428 0092 10						
16x		428 0184 10						
 33 mm		553 0147 10						
		559 0039 10						
1x		821 0572 10						
1x		821 0571 10						
		 ;  right		713 0087 20				
		 ;  left		713 0406 20				
		 ;  3603472→		713 6680 50				
		 ;  →3603471		713 6679 80				
				771 0537 30				
		 92 mm		814 0178 10				
		 ; →08.10;  →3603472		818 0306 10				
		 92 mm		818 0307 10				
		 ; →06.11		825 0250 10				
		 ;  3603472→		840 0313 10				
		 →3603471;  right; 		840 1015 10				
		 →3603471;  left; 		840 1016 10				
 →3603471; 		600 0290 00						
		 716.637 ;  N° 011089→		624 3162 09				
		 716.652		624 3162 34				
		incl.  ; incl. 						
		SAC						
		 716.637 ;  N° 011089→						
 716.652								
SAC								



			<p>SCHAEFFLER</p>
--	--	--	--------------------------

MERCEDES-BENZ

VITO (639)

111 CDI (639.601, 639.603)
 OM 646.980; OM 646.982; (85kW)

<p>09.07-</p>	<p>LUK</p>	<p> 415 0242 10</p> <p> 411 0147 10</p> <p> 529 0115 10</p> <p> 532 0391 20</p> <p> 532 0108 10</p> <p> 532 0160 10</p> <p> 533 0017 10</p> <p> 534 0481 10</p> <p> 535 0050 10</p> <p> 535 0168 10</p> <p> 544 0116 10</p> <p> FB 6PK2260</p> <p> FB 6PK2270</p> <p> FB 6PK2280</p> <p> 538 0224 10</p> <p> 420 0170 10</p> <p> 428 0092 10</p> <p> 428 0184 10</p> <p> 553 0147 10</p> <p> 559 0039 10</p>	<p> 821 0572 10</p> <p> 821 0571 10</p> <p> 713 0087 20</p> <p> 713 0406 20</p> <p> 713 6680 50</p> <p> 713 6679 80</p> <p> 771 0537 30</p> <p> 814 0178 10</p> <p> 818 0306 10</p> <p> 818 0307 10</p> <p> 825 0250 10</p> <p> 840 0313 10</p> <p> 840 1015 10</p> <p> 840 1016 10</p>
	<p>INA</p>	<p> ; A/C</p> <p> A/C ; </p> <p> ; A/C</p> <p> ; 2x</p> <p> ; OPTION</p> <p></p> <p> # F-233197.XX F-559320.XX</p> <p> # F-552901.XX</p> <p> ; PTO</p> <p> ; PTO ; →158569</p> <p> ; 158570→ ; PTO</p>	
	<p>FAG</p>	<p> ; right</p> <p> ; left</p> <p> ; 3603472→</p> <p> ; →3603471</p> <p></p> <p> 92 mm</p> <p> ; →08.10; →3603472</p> <p> 92 mm</p> <p> ; →06.11</p> <p> ; 3603472→</p> <p> →3603471; right; </p> <p> →3603471; left; </p> <p> →3603471; </p> <p></p> <p> right</p> <p> left</p>	

111 CDI (639.701, 639.703, 639.705)
 OM 646.982; (80kW)

<p>09.03-</p>	<p>LUK</p>	<p> 716.637 ; № 011089→</p> <p> 716.652</p> <p> incl. ; incl. </p> <p> SAC</p> <p> 716.637 ; № →011088</p> <p> SAC</p> <p> 716.637 ; № 011089→</p> <p> 716.652</p> <p> SAC</p>	<p> 600 0290 00</p> <p> 624 3162 09</p> <p> 624 3162 33</p> <p> 624 3162 34</p> <p> 415 0242 10</p> <p> 411 0147 10</p> <p> 529 0115 10</p> <p> 532 0391 20</p> <p> 532 0108 10</p> <p> 532 0160 10</p> <p> 533 0017 10</p> <p> 534 0481 10</p> <p> 535 0050 10</p> <p> 535 0168 10</p> <p> 544 0116 10</p> <p> FB 6PK2260</p> <p> FB 6PK2270</p> <p> FB 6PK2280</p> <p> 538 0224 10</p> <p> 420 0170 10</p> <p> 428 0092 10</p> <p> 428 0184 10</p> <p> 553 0147 10</p> <p> 559 0039 10</p>
	<p>INA</p>	<p> ; A/C</p> <p> A/C ; </p> <p> ; A/C</p> <p> ; 2x</p> <p> ; OPTION</p> <p></p> <p> # F-233197.XX F-559320.XX</p> <p> # F-552901.XX</p> <p> ; PTO</p> <p> ; PTO ; →158569</p> <p> ; 158570→ ; PTO</p>	
	<p>FAG</p>	<p> ; right</p> <p> ; left</p>	<p> 821 0572 10</p> <p> 821 0571 10</p>



			SCHAEFFLER	
--	--	--	-------------------	--

MERCEDES-BENZ

VITO (639)					
111 CDI (639.701, 639.703, 639.705) OM 646.982; (80kW)	09.03-	FAG	3603472 → →3603471 92 mm →08.10; →3603472 92 mm →06.11 3603472 → →3603471; right; →3603471; left; →3603471; right left	713 0087 20 713 0406 20 Set 713 6680 50 Set 713 6679 80 771 0537 30 814 0178 10 818 0306 10 818 0307 10 825 0250 10 840 0313 10 840 1015 10 840 1016 10	
111 CDI (639.701, 639.703, 639.705) OM 646.980; (85kW)	09.07-	LUK	716.637 ; N° 011089 → 716.652 incl. ; incl. SAC 716.637 ; N° 011089 → 716.652 SAC	600 0290 00 624 3162 09 624 3162 34 415 0242 10 411 0147 10	
			; A/C A/C ; ; A/C ; 2x ; OPTION # F-233197.XX F-559320.XX # F-552901.XX ; PTO ; PTO ; →158569 ; 158570 → ; PTO	529 0115 10 532 0391 20 532 0108 10 532 0160 10 533 0017 10 534 0481 10 535 0050 10 535 0168 10 FB 6PK2260 FB 6PK2270 FB 6PK2280 538 0224 10 420 0170 10	
		FAG	; right ; left 3603472 → →3603471 92 mm →08.10; →3603472 92 mm →06.11 3603472 → →3603471; right; →3603471; left; →3603471; right left	821 0572 10 821 0571 10 713 0087 20 713 0406 20 Set 713 6680 50 Set 713 6679 80 771 0537 30 814 0178 10 818 0306 10 818 0307 10 825 0250 10 840 0313 10 840 1015 10 840 1016 10	
111 CDI 4x4 (639.601, 639.603, 639.605, 639.701, 639.703, 639.705) OM 646.982; (80kW)	09.07-	LUK	716.637 ; N° 011089 → 716.652 incl. ; incl. SAC 716.637 ; N° →011088 SAC 716.637 ; N° 011089 → 716.652 SAC	600 0290 00 624 3162 09 624 3162 33 624 3162 34 415 0242 10 411 0147 10	



			SCHAEFFLER
--	---	--	-------------------













































































MERCEDES-BENZ

VITO (639)

111 CDI 4x4 (639.601, 639.603, 639.605, 639.701, 639.703, 639.705)
 OM 646.982; (80kW)

09.07-























	A/C		529 0115 10
	A/C ; 		532 0391 20
	A/C		532 0108 10
	2x		532 0160 10
	OPTION		533 0017 10
			534 0481 10
	F-233197.XX F-559320.XX		535 0050 10
	F-552901.XX		535 0168 10
	PTO		544 0116 10
	PTO ; 		FB 6PK2260
	PTO ; 		FB 6PK2270
	158570 ; 		FB 6PK2280
			538 0224 10
	16x		420 0170 10
	33 mm		428 0092 10
			428 0184 10
	1x		553 0147 10
	1x		559 0039 10
	FAG ; 		821 0572 10
	FAG ; 		821 0571 10
			713 0087 20
			713 0406 20
	92 mm		713 6679 80
	92 mm ; 		713 6679 80
	92 mm		771 0537 30
			814 0178 10
			818 0306 10
			818 0307 10
			825 0250 10
			840 0313 10
	right		840 1015 10
	left		840 1016 10

FAG



















































113 CDI (639.601, 639.603, 639.605, 639.701, 639.703, 639.705)
 OM 651.940; (100kW)

09.10-



	711.680 ; SA515411 04		600 0291 00
	716.637 ; 011089		
	716.652		
	incl. O		
	SAC		624 3408 09
	711.680 ; SA515411 04		624 3408 33
	716.637 ; 011089		
	716.652		
	SAC		415 0660 10
			411 0150 10

































































































































	START/STOP A/C		529 0361 10
	A/C		532 0108 10
			532 0570 10
			532 0671 10
			532 0672 10
	START/STOP		534 0337 10
	START/STOP		534 0444 10
	F-233197.XX F-559320.XX		535 0050 10
	F-552901.XX		535 0168 10
	08.14 ; START/STOP		FB 6PK2215
	START/STOP		538 0749 10
	START/STOP		538 0800 10
	16x		420 0225 10
	12 mm		
	16x		422 0099 10
			713 0087 20
			713 0406 20
	92 mm		713 6680 50
			814 0178 10
			818 0306 10
			818 0307 10
			825 0250 10

FAG



			SCHAEFFLER
--	---	--	-------------------

MERCEDES-BENZ

VITO (639)					
113 CDI (639.601, 639.603, 639.605, 639.701, 639.703, 639.705) OM 651.940; (100kW)	09.10-	FAG	 right  left	 840 0313 10  840 1015 10  840 1016 10	
	113 CDI 4x4 (639.601, 639.603, 639.605) OM 651.940; (100kW)	09.10-	LUK	 711.680 ;  SA515411 04  716.637 ;  N° 011089 →  716.652 incl.   SAC  711.680 ;  SA515411 04  716.637 ;  N° 011089 →  716.652 SAC	 600 0291 00  624 3408 09  624 3408 33
				 ; A/C    # F-233197.XX F-559320.XX # F-552901.XX  ; →08.14; START/STOP START/STOP START/STOP 16x  12 mm 16x	 415 0660 10  411 0150 10  532 0108 10  532 0671 10  532 0672 10  535 0050 10  535 0168 10  FB 6PK2215  538 0749 10  538 0800 10  420 0225 10
	FAG	 ;  3603472 →  ;  →3603471    92 mm  ;  3603472 →  →3603471;  right;   →3603471;  left;   →3603471;   right  left	 422 0099 10  713 0087 20  713 0406 20   713 6679 80  814 0178 10  818 0306 10  818 0307 10  825 0250 10  840 0313 10  840 1015 10  840 1016 10		
113 CDI 4x4 (639.701, 639.703, 639.705) OM 651.940; (100kW)	09.10-	LUK	 711.680 ;  SA515411 04  716.637 ;  N° 011089 →  716.652 incl.   SAC  711.680 ;  SA515411 04  716.637 ;  N° 011089 →  716.652 SAC	 600 0291 00  624 3408 09  624 3408 33	
				 ; START/STOP A/C  ; A/C      ; START/STOP  ; START/STOP # F-233197.XX F-559320.XX # F-552901.XX  ; →08.14; START/STOP START/STOP START/STOP 16x  12 mm 16x	 529 0361 10  532 0108 10  532 0570 10  532 0671 10  532 0672 10  534 0337 10  534 0444 10  535 0050 10  535 0168 10  FB 6PK2215  538 0749 10  538 0800 10  420 0225 10
FAG	 ;  3603472 →  ;  →3603471    92 mm  ;  3603472 →  →3603471;  right; 	 422 0099 10  713 0087 20  713 0406 20   713 6679 80  814 0178 10  818 0306 10			



			<p>SCHAEFFLER</p>
--	---	--	--------------------------

MERCEDES-BENZ

VITO (639)

<p>113 CDI 4x4 (639.701, 639.703, 639.705) OM 651.940; (100kW)</p>	<p>09.10-</p>	<p>FAG</p>	<p> →3603471; left; right →3603471; left right left</p>	<p> 818 0307 10 825 0250 10 840 0313 10 840 1015 10 840 1016 10</p>
<p>115 CDI (639.601, 639.603, 639.605, 639.701, 639.703, 639.705) OM 646.980; OM 646.982; (110kW)</p>	<p>09.03-</p>	<p>LUK</p>	<p> 716.637; № 011089 → 716.652 incl. ; incl. SAC 716.637; № →011088 SAC 716.637; № 011089 → 716.652 SAC</p>	<p> 600 0290 00 624 3162 09 624 3162 33 624 3162 34 415 0242 10 411 0147 10 529 0115 10 532 0391 20 532 0108 10 532 0160 10 533 0017 10 534 0481 10 535 0050 10 535 0168 10 544 0116 10 FB 6PK2260 FB 6PK2270 FB 6PK2280 538 0224 10 420 0170 10 428 0092 10 428 0184 10 553 0147 10 559 0039 10</p>
<p>115 CDI 4x4 (639.601, 639.603, 639.605, 639.701, 639.705) OM 646.982; (110kW)</p>	<p>07.06-</p>	<p>LUK</p>	<p> 716.637; № 011089 → 716.652 incl. ; incl. SAC 716.637; № →011088 SAC 716.637; № 011089 → 716.652 SAC</p>	<p> 600 0290 00 624 3162 09 624 3162 33 624 3162 34 415 0242 10 411 0147 10 529 0115 10 532 0391 20 532 0108 10 532 0160 10 533 0017 10 534 0481 10 535 0050 10</p>



			SCHAEFFLER	
--	--	--	------------	--

MERCEDES-BENZ

VITO (639)					
115 CDI 4x4 (639.601, 639.603, 639.605, 639.701, 639.705) OM 646.982; (110kW)	07.06-		F-552901.XX	535 0168 10	
			; PTO	544 0116 10	
			; PTO ; →158569	FB 6PK2260	
			; 158570→; PTO	FB 6PK2270	
			; 158570→; PTO	FB 6PK2280	
			16x	538 0224 10	
			33 mm	420 0170 10	
				428 0092 10	
				428 0184 10	
			1x	OILP 553 0147 10	
			1x	KIT 559 0039 10	
			FAG	; right	821 0572 10
			FAG	; left	821 0571 10
			FAG	; 3603472→	713 0087 20
			FAG	; →3603471	713 0406 20
			FAG		Set 713 6679 80
			FAG	92 mm	Set 713 6679 80
			FAG	; →08.10; →3603472	Set 713 6679 80
			FAG	92 mm	814 0178 10
			FAG	; 3603472→	818 0306 10
			FAG	→3603471; right; ←	818 0307 10
			FAG	→3603471; left; ←	825 0250 10
			FAG	→3603471;	840 0313 10
			FAG	right	840 1015 10
FAG	left	840 1016 10			
116 CDI (639.601, 639.603, 639.605, 639.701, 639.703, 639.705) OM 651.940; (120kW)	09.10-		711.680 ; SA515411 04	600 0291 00	
			716.637 ; N° 011089→		
			716.652		
			incl.		
			SAC	624 3408 09	
			711.680 ; SA515411 04	624 3408 33	
			716.637 ; N° 011089→		
			716.652		
			SAC	415 0660 10	
				411 0150 10	
				; START/STOP A/C	KIT 529 0361 10
				; A/C	532 0108 10
				;	532 0570 10
					532 0671 10
					532 0672 10
				; START/STOP	534 0337 10
				; START/STOP	534 0444 10
				F-233197.XX F-559320.XX	535 0050 10
				F-552901.XX	535 0168 10
				; →08.14; START/STOP	FB 6PK2215
				START/STOP	538 0749 10
				START/STOP	538 0800 10
				16x	420 0225 10
				12 mm	
	16x	422 0099 10			
FAG	; 3603472→	713 0087 20			
FAG	; →3603471	713 0406 20			
FAG		Set 713 6680 50			
FAG	92 mm	814 0178 10			
FAG	; 3603472→	818 0306 10			
FAG	→3603471; right; ←	818 0307 10			
FAG	→3603471; left; ←	825 0250 10			
FAG	→3603471;	840 0313 10			
FAG	right	840 1015 10			
FAG	left	840 1016 10			
116 CDI 4x4 (639.601, 639.603, 639.605) OM 651.940; (120kW)	09.10-		711.680 ; SA515411 04	600 0291 00	
			716.637 ; N° 011089→		
			716.652		
			incl.		
SAC	624 3408 09				

























			<p>SCHAEFFLER</p>
--	--	--	--------------------------



























MERCEDES-BENZ

VITO (639)



116 CDI 4x4 (639.601, 639.603, 639.605) 09.10-
 OM 651.940; (120kW)

	711.680 ; SA515411 04 716.637 ; N° 011089 → 716.652 SAC		624 3408 33
	A/C 16x 12 mm 16x	        	415 0660 10 411 0150 10 532 0108 10 532 0671 10 532 0672 10 535 0050 10 535 0168 10 FB 6PK2215 538 0749 10 538 0800 10 420 0225 10
	3603472 → →3603471 92 mm 3603472 → →3603471; right; →3603471; left; →3603471; right left	        	422 0099 10 713 0087 20 713 0406 20 713 6679 80 814 0178 10 818 0306 10 818 0307 10 825 0250 10 840 0313 10 840 1015 10 840 1016 10

116 CDI 4x4 (639.701, 639.703, 639.705) 09.10-
 OM 651.940; (120kW)

	711.680 ; SA515411 04 716.637 ; N° 011089 → 716.652 incl.  SAC		600 0291 00
	START/STOP A/C A/C 16x 12 mm 16x	           	624 3408 09 624 3408 33 415 0660 10 411 0150 10 529 0361 10 532 0108 10 532 0570 10 532 0671 10 532 0672 10 534 0337 10 534 0444 10 535 0050 10 535 0168 10 FB 6PK2215 538 0749 10 538 0800 10 420 0225 10
	3603472 → →3603471 92 mm 3603472 → →3603471; right; →3603471; left; →3603471; right left	        	422 0099 10 713 0087 20 713 0406 20 713 6679 80 814 0178 10 818 0306 10 818 0307 10 825 0250 10 840 0313 10 840 1015 10 840 1016 10











































































































































119 (639.601, 639.603, 639.605) 09.03-
 M 112.951; (140kW)

	+ ACC 16x	 	529 0035 10 532 0160 10 534 0114 20
---	--------------	--	---



			SCHAEFFLER
--	---	--	-------------------

MERCEDES-BENZ











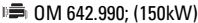









































































MERCEDES-BENZ					
<p>VITO (639) 119 (639.601, 639.603, 639.605) M 112.951; (140kW)</p>	09.03-			 FB 6PK2315	
			 12x;  11 mm	 538 0211 10	
			 6x;  11 mm	 420 0063 10	
			1x	 OILP 553 0296 10	
			1x	 KIT 559 0042 10	
			FAG	 right	 821 0572 10
				 left	 821 0571 10
				 ;  3603472 →	 713 0087 20
				 ;  →3603471	 713 0406 20
				 92 mm	 Set 713 6680 50
		 ; →08.10;  →3603472		 Set 713 6679 80	
		 92 mm			
		 ;  3603472 →		 814 0178 10	
		 →3603471;  right; 		 818 0306 10	
		 →3603471;  left; 		 818 0307 10	
		 →3603471; 	 825 0250 10		
			 840 0313 10		
		 right	 840 1015 10		
		 left	 840 1016 10		
		<p>119 (639.701, 639.703, 639.705) M 112.951; (140kW)</p>	09.03-		+ ACC
	 532 0160 10				
	 534 0114 20				
	 FB 6PK2315				
 12x;  11 mm	 538 0212 10				
 6x;  11 mm	 420 0063 10				
 1x	 OILP 553 0296 10				
1x	 KIT 559 0042 10				
FAG	 right				 821 0572 10
	 left				 821 0571 10
	 ;  3603472 →			 713 0087 20	
	 ;  →3603471			 713 0406 20	
	 92 mm			 Set 713 6680 50	
	 ; →08.10;  →3603472			 Set 713 6679 80	
	 92 mm				
	 ;  3603472 →			 814 0178 10	
	 →3603471;  right; 			 818 0306 10	
	 →3603471;  left; 			 818 0307 10	
 →3603471; 	 825 0250 10				
	 840 0313 10				
 right	 840 1015 10				
 left	 840 1016 10				
<p>120 CDI (639.601, 639.603, 639.605, 639.701, 639.703, 639.705) OM 642.990; (150kW)</p>	07.06-		 ; +  ;  # F-239808.XX; A/C	 529 0169 10	
			 ; 2x	 532 0234 10	
				 534 0183 10	
			 # F-233197.XX F-559320.XX	 535 0050 10	
			 # F-239808.XX	 535 0140 10	
				 FB 7PK2035	
				 538 0234 10	
				 538 0244 10	
			 24x	 420 0086 10	
			 12 mm		
		24x	 422 0056 10		
		1x; →09.14;  →41633498	 KIT 558 0039 10		
		1x	 KIT 559 0049 10		
		1x	 KIT 559 0050 10		
		1x; →09.14;  →41633498	 KIT 559 0087 10		
		1x; →09.14;  →41633498	 KIT 559 0088 10		
		1x	 KIT OILP 558 0040 10		
		FAG	 right	 821 0572 10	
			 left	 821 0571 10	
			 ;  3603472 →	 713 0087 20	



			SCHAEFFLER
--	---	--	-------------------

MERCEDES-BENZ





















































































































































VITO (639)

<p>120 CDI (639.601, 639.603, 639.605, 639.701, 639.703, 639.705)  OM 642.990; (150kW)</p>	07.06-	FAG	 ;  →3603471		713 0406 20
				 Set	713 6680 50
			 92 mm		
			 ; →08.10;  →3603472	 Set	713 6679 80
			 92 mm		
			 ;  3603472→		814 0178 10
			 →3603471;  right; 		818 0306 10
			 →3603471;  left; 		818 0307 10
			 →3603471; 		825 0250 10
					840 0313 10
			 right		840 1015 10
			 left		840 1016 10
					529 0035 10
					532 0160 10
					534 0114 20
		FB 6PK2315			
		538 0211 10			
		420 0063 10			
		420 0076 10			
	 OILP	553 0296 10			
	 KIT	559 0042 10			
		821 0572 10			
		821 0571 10			
		713 0087 20			
		713 0406 20			
	 Set	713 6680 50			
	 Set	713 6679 80			
		814 0178 10			
		818 0306 10			
		818 0307 10			
		825 0250 10			
		840 0313 10			
		840 1015 10			
		840 1016 10			
		529 0035 10			
		532 0160 10			
		534 0114 20			
		FB 6PK2315			
		538 0212 10			
		420 0063 10			
		420 0076 10			
	 OILP	553 0296 10			
	 KIT	559 0042 10			
		821 0572 10			
		821 0571 10			
		713 0087 20			
		713 0406 20			
	 Set	713 6680 50			
	 Set	713 6679 80			
		814 0178 10			
		818 0306 10			
		818 0307 10			
		825 0250 10			
		840 0313 10			
		840 1015 10			
		840 1016 10			
		529 0169 10			
		532 0234 10			
		534 0183 10			
		535 0050 10			
		535 0140 10			



			SCHAEFFLER
--	---	--	-------------------

MERCEDES-BENZ

































































































































































VITO (639)					
122 CDI (639.601, 639.603, 639.605) OM 642.890; (165kW)	09.10-				FB 7PK2035
			 40582550→		538 0234 10
			24x		420 0086 10
			 12 mm		
			24x		422 0056 10
			1x; →04.15;  →41711428		558 0039 10
			1x		559 0049 10
			1x		559 0050 10
			1x; →04.15;  →41711428		559 0087 10
			1x; →04.15;  →41711428		559 0088 10
		1x		558 0040 10	
		FAG	 ;  3603472→		713 0087 20
			 ;  →3603471		713 0406 20
					713 6680 50
			 92 mm		
			 ;  3603472→		814 0178 10
			 →3603471;  right; 		818 0306 10
			 →3603471;  left; 		818 0307 10
			 →3603471; 		825 0250 10
					840 0313 10
 right			840 1015 10		
 left		840 1016 10			
122 CDI (639.701, 639.703, 639.705) OM 642.890; (165kW)	09.10-		 ; +  ;  # F-239808.XX; A/C		529 0169 10
			 ; 2x		532 0234 10
			 # F-233197.XX F-559320.XX		534 0183 10
			 # F-239808.XX		535 0050 10
					535 0140 10
			 40582550→		FB 7PK2035
			 40582550→		538 0234 10
			24x		420 0086 10
			 12 mm		
			24x		422 0056 10
		1x; →04.15;  →41711428		558 0039 10	
		1x; →04.15;  →41711428		559 0087 10	
		1x; →04.15;  →41711428		559 0088 10	
		1x		558 0040 10	
		FAG	 ;  3603472→		713 0087 20
			 ;  →3603471		713 0406 20
					713 6680 50
			 92 mm		
			 ;  3603472→		814 0178 10
			 →3603471;  right; 		818 0306 10
 →3603471;  left; 			818 0307 10		
 →3603471; 			825 0250 10		
			840 0313 10		
 right			840 1015 10		
 left		840 1016 10			
123 (639.601, 639.603, 639.605) M 112.976; (165kW)	06.04-07.08		+ ACC		529 0035 10
					532 0160 10
					534 0114 20
					538 0212 10
					713 0087 20
		FAG	 ;  3603472→		713 0087 20
			 ;  →3603471		713 0406 20
					713 6680 50
			 92 mm		713 6679 80
			 92 mm		
 ;  3603472→		814 0178 10			
 →3603471;  right; 		818 0306 10			
 →3603471;  left; 		818 0307 10			
 →3603471; 		825 0250 10			
		840 0313 10			
 right		840 1015 10			
 left		840 1016 10			
123 (639.601) M 112.976; (170kW)	06.04-07.08		+ ACC		529 0035 10
					532 0160 10
					534 0114 20
					538 0212 10



			SCHAEFFLER
--	--	--	-------------------

MERCEDES-BENZ













































































VITO (639)



























































123 (639.601) M 112.976; (170kW)	06.04-07.08	 FAG	12x;  M112.976;   11 mm 6x;  M112.976;   11 mm 1x  OILP 553 0296 10 1x  KIT 559 0042 10  right  821 0572 10  left  821 0571 10   3603472 →  713 0087 20   →3603471  713 0406 20   92 mm  Set 713 6680 50   92 mm  Set 713 6679 80   3603472 →  814 0178 10   →3603471;  right;   818 0306 10   →3603471;  left;   818 0307 10   →3603471;   825 0250 10   840 0313 10  right  840 1015 10  left  840 1016 10	420 0063 10 420 0076 10 553 0296 10 559 0042 10 821 0572 10 821 0571 10 713 0087 20 713 0406 20 713 6680 50 713 6679 80 814 0178 10 818 0306 10 818 0307 10 825 0250 10 840 0313 10 840 1015 10 840 1016 10
123 (639.701, 639.703, 639.705) M 112.976; (165kW)	06.04-07.08	 FAG	+ ACC  529 0035 10   532 0160 10   534 0114 20   538 0212 10   3603472 →  713 0087 20   →3603471  713 0406 20   92 mm  Set 713 6680 50   →3603471;  ; →31.08.2010  Set 713 6679 80   92 mm  Set 713 6679 80   92 mm  814 0178 10   →3603471;  right;   818 0306 10   →3603471;  left;   818 0307 10   →3603471;   840 0313 10  right  840 1015 10  left  840 1016 10	529 0035 10 532 0160 10 534 0114 20 538 0212 10 713 0087 20 713 0406 20 713 6680 50 713 6679 80 713 6679 80 814 0178 10 818 0306 10 818 0307 10 840 0313 10 840 1015 10 840 1016 10
123 (639.701) M 112.976; (170kW)	06.04-	 FAG	+ ACC  529 0035 10   532 0160 10   534 0114 20   538 0212 10 12x;   420 0063 10  11 mm 6x;   420 0076 10  11 mm 1x  OILP 553 0296 10 1x  KIT 559 0042 10  right  821 0572 10  left  821 0571 10   3603472 →  713 0087 20   →3603471  713 0406 20   92 mm  Set 713 6680 50   ; →08.10;  →3603472  Set 713 6679 80   3603472 →  814 0178 10   →3603471;  right;   818 0306 10   →3603471;  left;   818 0307 10   →3603471;   825 0250 10   840 0313 10  right  840 1015 10  left  840 1016 10	529 0035 10 532 0160 10 534 0114 20 538 0212 10 420 0063 10 420 0076 10 553 0296 10 559 0042 10 821 0572 10 821 0571 10 713 0087 20 713 0406 20 713 6680 50 713 6679 80 814 0178 10 818 0306 10 818 0307 10 825 0250 10 840 0313 10 840 1015 10 840 1016 10
126 (639.601, 639.603, 639.605, 639.701, 639.703, 639.705) M 272.978; (190kW)	09.07-	 A/C	A/C  529 0034 10   532 0539 10   532 0866 10   MANU  533 0100 10   534 0067 10	529 0034 10 532 0539 10 532 0866 10 533 0100 10 534 0067 10



			SCHAEFFLER
--	---	--	-------------------

MERCEDES-BENZ

VITO (639)				
126 (639.601, 639.603, 639.605, 639.701, 639.703, 639.705) M 272.978; (190kW)	09.07-		 FB 6PK2403	
			 538 0244 10	
			 24x	
			 420 0086 10	
			 12 mm	
			 24x	
			 422 0055 10	
			 1x	
			 558 0041 10	
			 1x	
		 559 0093 10		
		FAG	 right	 821 0572 10
			 left	 821 0571 10
			 ;  3603472 →	 713 0087 20
			 ;  → 3603471	 713 0406 20
			 92 mm	 713 6680 50
			 ; → 08.10;  → 3603472	 713 6679 80
			 92 mm	
			 ;  3603472 →	 814 0178 10
			 → 3603471;  right;  ←	 818 0306 10
 → 3603471;  left;  ←	 818 0307 10			
 → 3603471; 	 825 0250 10			
	 840 0313 10			
 right	 840 1015 10			
 left	 840 1016 10			
E-CELL (639.601, 639.603, 639.605, 639.703) EM 780.994; (60kW)	03.12-	FAG	 ;  3603472 →	 713 0087 20
			 ;  → 3603471	 713 0406 20
			 92 mm	 713 6680 50
			 ;  3603472 →	 814 0178 10
			 → 3603471;  right;  ←	 818 0306 10
			 → 3603471;  left;  ←	 818 0307 10
			 → 3603471; 	 825 0250 10
				 840 0313 10
			 right	 840 1015 10
			 left	 840 1016 10













































































VITO (W447)							
109 CDI / 109 BlueTEC (447.701, 447.703, 447.705) 109 CDI (447.601, 447.603, 447.605, 447.701, 447.703, 447.705) 111 CDI / 111 BlueTEC (447.701, 447.703, 447.705) 111 CDI (447.601, 447.603, 447.605, 447.701, 447.703, 447.705) OM 622.951; (65-84kW)	10.14-	LUK	SAC	 624 3930 33			
			 415 0796 10				
				 529 0246 10			
			 # F-552305.XX	 535 0153 10			
			 16x	 538 0399 10			
		FAG	 420 0086 10				
			 16x	 422 0078 10			
				 814 0178 10			
			114 CDI / 114 BlueTEC (447.701, 447.703, 447.705) OM 651.950; (100kW)	10.14-	LUK	G6 ;  ZF 6S-450	 624 3408 33
						SAC	
G6 ;  TSG 380	 624 3762 09						
SAC							
 MANU ;  TSG 380	 624 3762 33						
		 415 0657 10					
		 532 0108 10					
		 532 0571 10					
		 534 0611 10					
	 # F-552901.XX	 535 0168 10					
FAG		 538 0804 10					
	 420 0225 10						
	 16x	 422 0099 10					
	 12 mm	 814 0178 10					
		 624 3762 33					
114 CDI / 114 BlueTEC 4-matic (447.701, 447.703, ...) OM 651.950; (100kW)	07.15-	LUK	SAC	 624 3762 33			
			 532 0108 10				
			 ;  A/C	 532 0571 10			
				 534 0611 10			
				 535 0168 10			
			 # F-552901.XX	 538 0804 10			
				 420 0225 10			
 16x	 422 0099 10						
 12 mm							
							



			SCHAEFFLER
--	--	--	-------------------

MERCEDES-BENZ





































VITO (W447)

114 CDI / 114 BlueTEC 4-matic (447.701, 447.703, ..)  OM 651.950; (100kW)	07.15-	FAG 		814 0178 10
114 CDI (447.601, 447.603, 447.605, 447.701, 447.703, 447.705)  OM 651.950; (100kW)	10.14-	LUK 	     	624 3408 33 624 3762 09 624 3762 33
		INA 	     	415 0657 10 532 0108 10 532 0571 10 534 0611 10 535 0168 10 538 0804 10 420 0225 10
		FAG 		422 0099 10
114 CDI 4-matic (447.701, 447.703, 447.705) 114 CDI 4x4 (447.601, 447.603, 447.605)  OM 651.950; (100kW)	07.15-	INA 	     	814 0178 10 532 0108 10 532 0571 10 534 0611 10 535 0168 10 538 0804 10 420 0225 10
		FAG 		422 0099 10
116 CDI / 116 BlueTEC (447.701, 447.703, 447.705)  OM 651.950; (120kW)	10.14-	LUK 	     	814 0178 10 624 3408 33 624 3762 09 624 3762 33
		INA 	     	415 0657 10 532 0108 10 532 0571 10 534 0611 10 535 0168 10 538 0804 10 420 0225 10
		FAG 		422 0099 10
116 CDI / 116 BlueTEC 4-matic (447.701, 447.703, ..)  OM 651.950; (120kW)	07.15-	INA 	     	814 0178 10 532 0108 10 532 0571 10 534 0611 10 535 0168 10 538 0804 10 420 0225 10
		FAG 		422 0099 10
116 CDI (447.601, 447.603, 447.605, 447.701, 447.703, 447.705)  OM 651.950; (120kW)	10.14-	LUK 	     	814 0178 10 624 3408 33 624 3762 09 624 3762 33
		INA 	     	415 0657 10 532 0108 10 532 0571 10 534 0611 10 535 0168 10 538 0804 10 420 0225 10
		FAG 		422 0099 10
		FAG 		814 0178 10

































































































			SCHAEFFLER
--	--	--	-------------------

MERCEDES-BENZ

VITO (W447)						
116 CDI 4-matic (447.701, 447.703, 447.705) 116 CDI 4x4 (447.601, 447.603, 447.605) OM 651.950; (120kW)	07.15-		 ; A/C		532 0108 10	
					532 0571 10	
					534 0611 10	
			# F-552901.XX		535 0168 10	
					538 0804 10	
			16x		420 0225 10	
			 12 mm			
			16x		422 0099 10	
			FAG		814 0178 10	
			119 BlueTEC (447.701, 447.703, 447.705) 119 BlueTEC 4-matic (447.701, 447.703, 447.705) 119 CDI / 119 BlueTEC (447.701, 447.703, 447.705) 119 CDI / 119 BlueTEC 4-matic (447.701, 447.703, ..) 119 CDI / BlueTEC (447.601, 447.603, 447.605) OM 651.950; (140kW)	10.14-		
		532 0571 10				
		534 0611 10				
# F-552901.XX		535 0168 10				
		538 0804 10				
16x		420 0225 10				
 12 mm						
16x		422 0099 10				
FAG		814 0178 10				
119 CDI / BlueTEC 4x4 (447.601, 447.603, 447.605) OM 651.950; (140kW)	07.15-					 ; A/C
					532 0571 10	
					534 0611 10	
			# F-552901.XX		535 0168 10	
					538 0804 10	
			16x		420 0225 10	
			 12 mm			
			16x		422 0099 10	
			FAG		814 0178 10	

MITSUBISHI





































Canter (FE5, FE6) 6.Generation						
Canter 35 Canter 55 4M42-0AT;	09.01-		01.05 → 04.06;  BM FE5;  FB83B;  M027S5A		628 3294 09	
			→ 02.05;  BM FE 534;  FA6;  M025S5 ; G4		628 3319 00	
			→ 02.05;  BM FE 544;  FA6;  M025S5 ; G5			
			→ 02.05;  BM FB631;  FA5;  M025S5 ; G5			
			→ 02.05;  BM FB 641;  FA5;  M025S5 ; G5			
Canter 75 4D34-2AT6;	09.01-		→ 01.10;  BM FE 659;  F95;  M035S5 ; G5		630 3146 00	
			07.02 → 07.04;  BM FE 659;  FC9;  M035S5 ; G5			
			→ 02.05;  BM FE 659;  FA7;  M05S35 ; G5		630 3157 00	
413 4P10-T2;	01.12-		 BM FEA01;  FN1;  275 mm;  M038S6		628 3294 09	
			 BM FEB01;  FM9 275;  M038S6			
515, 516 615, 616 715 4P10-7AT4; 4P10-T4;	01.12-		 BM FEA01;  FN1;  275 mm;  M038S6		628 3294 09	
			 BM FEB01;  FM9;  275 mm;  M038S6			
6C18 4X4 4P10-T4;	01.12-		 BM FEA01;  FN1;  275 mm;  M038S6		628 3294 09	
			 BM FEB01;  FM9;  275 mm;  M038S6			
815, 816 4P10-7AT4; 4P10-T4;	01.12-		 BM FEA01;  FN1;  275 mm;  M038S6		628 3294 09	
			 BM FEB01;  FM9;  275 mm;  M038S6			
916, 918 4P10-7AT6; 4P10-T6;	01.12-		 BM FEA01;  FN1;  275 mm;  M038S6		628 3294 09	
			07.12 →;  BM 91EEC;  FL4;  M038S5			
616 4P10-7AT4;	08.12-		 BM FEA01;  FN1;  275 mm;  M038S6		628 3294 09	
			 BM FEB01;  FM09;  275 mm;  M038S6			
7C15 EcoHybrid	09.12-		 BM FE82 B;  EG4/ EG5;  M02S5		628 3294 09	
			# F-560671.XX		535 0235 10	











































			SCHAEFFLER
--	---	--	-------------------

MITSUBISHI

























Canter (FB7, FB8, FE7, FE8) 7.Generation

3C13 4M42-0AT;	10.01-		01.07→;  BM FE84 B;  FG7;  M036S6 ; G6		630 3131 09
			01.07→;  BM FE85 B;  FG7;  M036S6 ; G6		
			 TR ; 01.07→;  BM FE85 B;  FH7;  M036S6 ; G6		
			04.06→11.09;  BM FE84 B;  FE6;  M036S6 ; G6		
6C18 4P10-0AT6; 4P10-T6;	08.05-		12.11→ # F-560671.XX		535 0235 10
3C11 3C15 4M42-0AT; 4M42-3AT1; 4M42-3AT4;	06.06-		 BM FE84 B;  FG7;  M036S6 ; G6		630 3131 09
			 BM FE85 B;  FG7;  M036S6 ; G6		
			 TR ;  BM FE85 B;  FH7;  M036S6 ; G6		
			→11.09;  BM FE84 B;  FE6;  M036S6 ; G6		
			→11.09;  BM FB85 B;  FE6;  M036S6 ; G6		630 3149 09

L200 / TRITON Platform/Chassis (KA, T, KB, T)

















2.5 DI-D (KA4T) 4D56 (16V); (94kW)	08.07-12.15		BS		530 0594 10		
			 2x			531 0231 20	
			 2x			531 0834 10	
			 2x			532 0599 10	
			 2x			533 0113 10	
			 2x			534 0477 10	
			 2x ; →02.13; EURO 4			FB 6PK1495	
			 2x ; 08.11→; EURO 5			FB 6PK1510	
			A/C			FB 13X900	
			FAG right			840 1199 10	
			FAG left			840 1198 10	
			2.5 DI-D 4WD (KB4T) 4D56 HP; (131kW)		09.09-12.15		 BM HJNUZL6
	BS			530 0594 10			
	 2x			531 0231 20			
	 2x			531 0834 10			
	 2x			532 0599 10			
	 2x			533 0113 10			
	 2x			534 0477 10			
	 2x ; →07.11; EURO 4			FB 6PK1495			
	 2x ; 08.11→; EURO 5			FB 6PK1510			
	A/C			FB 13X900			
	FAG ↑ up			538 0588 10			
	FAG right			825 0331 10			
	FAG left		840 1199 10				
			840 1198 10				

L300 (P0_W, P1_W, P2_W)

2.0 (P23V, P23V) 4G63 (SOHC 16V); (83kW)	11.03-02.06		BS;  4G63 G63B		530 0298 10	
			 4G63 G63B			530 0303 10
			BS;  4G63 G63B			531 0121 20
			 4G63 G63B			531 0193 20
			 4G63 G63B			532 0074 20
			 16x			533 0044 20
			 12,96 mm			420 0200 10
			FAG 			Set 713 6193 00
			 65 mm			Set 713 6194 00
						840 0052 10
						840 0099 10
						840 0637 10

NISSAN

CABSTAR (F24M, F24W)























28.11 DCI, 32.11 DCI, 35.11 DCI 2.5 (F24M) YD25DDTi; (81kW)	09.06-12.13		 5 MT ; G5		625 3201 00
			 ; →12.11 # F-552386.XX		
28.12 DCI, 32.12 DCI, 34.12 DCI, 35.12 DCI 2.5 (F24M) YD25DDTi; (90kW)	09.06-12.13		 5 MT ; G5		625 3199 09
			 ; 10.11→ # F-552386.XX		
35.13 DCI, 45.13 DCI 2.5 (F24M) YD25DDTi; (96kW)	09.06-12.12		 6 MT ; G6		625 3199 09
			 ; →09.11 # F-552386.XX		
					531 0931 10
					535 0177 10
					535 0177 10
					FB 7PK1753























































































































			SCHAEFFLER
--	--	--	-------------------

NISSAN

CABSTAR (F24M, F24W)

35.14 DCI, 45.14 DCI 2.5 (F24M)  YD25DDT; YD25K3LD-5MI; (100kW)	09.06-12.13		 5 MT ; G5		625 3201 00
			 ; 10.11→		531 0931 10
			 # F-552386.XX		535 0177 10
			 ; 10.11→; für Fahrzeuge mit Standard Kühlung		FB 7PK1753
35.14 DCI 3.0 (F24M) 35.15 DCI, 45.15 DCI 3.0 (F24M)  ZD30; ZD30DDT; ZD30H HD-5; (101-110kW)	09.06-12.13		 5MT ; G5		628 3342 00
			 5MT M ; G5		
			 6MT H		628 3362 00
			03.09→10.11;  6RTH		628 3362 00
		 ; A/C		529 0278 10	

INTERSTAR (X70)









































































































































dCi 80  F9Q 772; F9Q 774; (60kW)	04.02-08.06		→01.03;  F9Q 772		624 3087 09	
			→01.03;  F9Q 772;  PK5.0##		624 3087 33	
			01.03→;  F9Q 772;  PK5.3##		624 3087 34	
			01.03→;  F9Q 772		624 3312 09	
			 F9Q 774			
			01.03→;  F9Q 772		624 3312 33	
			 F9Q 774			
			 PK5.0##			
			01.03→;  F9Q 772		624 3312 34	
			 F9Q 774			
			 PK5.3##			
						530 0196 10
					530 0196 30	
					533 0087 20	
			 ; A/C		529 0124 10	
			 ; A/C		529 0427 10	
					532 0243 10	
			 # F-560843.XX F-556602.XX F-229643.XX		535 0030 10	
			 # F-234637.XX		535 0048 10	
					538 0392 10	
	FAG	 right ↓ down		821 0558 10		
		 left ↓ down		821 0557 10		
		 ;  16 "		Set 713 6307 90		
		 84 mm				
		 ;  15 "		Set 713 6308 00		
		 84 mm				
		 ;  16 "		Set 713 6307 80		
		 80 mm				
		 ;  15 "		Set 713 6308 10		
		 80 mm				
		 101,9 mm		771 0292 30		
		 right		818 0206 10		
		 left		818 0205 10		
		 ↓ down		825 0166 10		
		 ↑ up 		825 0167 10		
		 ↑ up 		825 0280 10		
				840 0198 10		
		 right		840 0878 10		
		 left		840 0877 10		
dCi 90  G9T 722; (66kW)	07.02-				624 3476 09	
			 PF1 PK5.0##		624 3476 33	
			 PK5.3##		624 3476 34	
						530 0198 10
					531 0548 10	
					532 0313 20	
			 ; →08.06;  A/C ;  ; # OE 6PK1835		529 0436 10	
			 ; →08.06;  A/C ; # OE 6PK1835			
					532 0243 10	
			A/C		532 0333 10	
			 ; →08.06		532 0364 20	
			 ; →08.06;  A/C		534 0181 10	
			 ; →08.06;  A/C ; 			
			 ; →08.06;  A/C ; 		534 0317 10	
	 # F-560843.XX F-556602.XX F-229643.XX		535 0030 10			
	 # F-238512.XX		535 0081 10			
	 ; →08.06;  A/C ; 		FB 6PK1148			



			<p>SCHAEFFLER</p>	
--	---	--	-------------------	--

NISSAN

INTERSTAR (X70)



















































































































































<p>dCi 90 G9T 722; (66kW)</p>	<p>07.02-</p>		<p>  ; A/C  ; →03.06; A/C  ; →03.06; A/C ; -e  ; →08.06; A/C  ; →08.06; A/C ; -e  ; →08.06; A/C ; -e 16x  11 mm 1x;  1x;  FAG  right ↓ down; →09.07  right ↓ down; 09.07 →  left ↓ down; →09.07  left ↓ down; 09.07 →  ;  16 "  ;  84 mm  ;  15 "  ;  84 mm  ;  16 "  ;  80 mm  ;  15 "  ;  80 mm  ;  101,9 mm  right  left  ↓ down; →09.07  ↑ up   ↑ up   ↓ down; 09.07 →   right  left </p>	<p>  FB 6PK1153  FB 6PK1795  FB 6PK1795  FB 6PK1835  538 0374 10  420 0063 10  428 0185 10  428 0186 10  821 0558 10  821 0857 10  821 0557 10  821 0855 10   713 6307 90   713 6308 00   713 6307 80   713 6308 10  771 0292 30  818 0206 10  818 0205 10  825 0166 10  825 0167 10  825 0280 10  825 0300 10  840 0198 10  840 0878 10  840 0877 10 </p>	
<p>dCi 100 G9U 720; G9U 754; (73kW)</p>	<p>11.03-</p>		<p> →12.05;  PK5.0##  PK5.0## PK6.0##  PK5.3## PK6.3##  PK5.3##    530 0198 10   531 0548 10  532 0313 20  ; →11.04;  G9U 754; A/C ; -e  ; →03.06; A/C ; -e ; # OE 6PK1835  ; →03.06;  G9U 720; A/C ; # OE 6PK1835  ; →03.06  ; →03.06; A/C  ; →03.06; A/C ; -e  ; →03.06; A/C ; -e  # F-560843.XX F-556602.XX F-229643.XX  # F-238512.XX  →03.06; A/C  ; OPTION  ; →03.06;  G9U 720; A/C ; -e  ; A/C  ; →03.06; A/C  ; →03.06; A/C ; -e  ; →08.06; A/C  ; →08.06; A/C ; -e  ; →03.06; A/C ; →03.06; A/C ; -e ; PTO ; A/C ; →03.06; G9U 754; A/C ; A/C ; PTO ; # OE 8200833558 ; A/C </p>	<p>  624 3476 09  624 3476 33  624 3476 33  624 3476 34  624 3476 34  530 0198 10   531 0548 10  532 0313 20  529 0432 10  529 0436 10  532 0364 20   534 0181 10   534 0317 10  535 0030 10  535 0081 10  544 0094 10  544 0110 10   FB 6PK1148   FB 6PK1153   FB 6PK1795   FB 6PK1795   FB 6PK1795  FB 7PK1113 FB 7PK1795 FB 7PK1795 538 0374 10 </p>	



			SCHAEFFLER
--	---	--	-------------------

NISSAN

INTERSTAR (X70)

dCi 100 G9U 720; G9U 754; (73kW)	11.03-		16x		420 0063 10
			 11 mm		428 0185 10
			1x; 		428 0186 10
			1x; 		428 0186 10
		FAG	 right ↓ down; →09.07		821 0558 10
			 right ↓ down; 09.07→		821 0857 10
			 left ↓ down; →09.07		821 0557 10
			 left ↓ down; 09.07→		821 0855 10
			 ;  16 "	 Set	713 6307 90
			 84 mm		
			 ;  15 "	 Set	713 6308 00
			 84 mm		
			 ;  16 "	 Set	713 6307 80
			 80 mm		
			 ;  15 "	 Set	713 6308 10
			 80 mm		
			 -  		771 0292 30
			 101,9 mm		
			 right		818 0206 10
			 left		818 0205 10
			 ↓ down; →09.07		825 0166 10
			 ↑ up 		825 0167 10
			 ↑ up 		825 0280 10
			 ↓ down; 09.07→		825 0300 10
					840 0198 10
			 right		840 0878 10
			 left		840 0877 10
dCi 100 G9U 720; G9U 754; (73kW)	02.04-	LUK			624 3476 09
			→12.05;  PK5.0##		624 3476 33
			 PK5.3##		624 3476 34
					530 0198 10
					531 0548 10
					532 0313 20
			 ; →08.06;  A/C ;  ; # OE 6PK1835		529 0436 10
			 ; →08.06; A/C ; # OE 6PK1835		
			 ; →08.06		532 0364 20
			 ; →08.06; A/C		534 0181 10
			 ; →08.06; A/C ; 		
			 ; →08.06; A/C ; 		534 0317 10
			 # F-560843.XX F-556602.XX F-229643.XX		535 0030 10
			 # F-238512.XX		535 0081 10
			 ; OPTION		544 0110 10
			 ; →08.06; A/C ; 		FB 6PK1148
			 ; A/C		FB 6PK1153
			 ; →08.06; A/C		FB 6PK1795
			 ; →08.06; A/C ; 		
			 ; →08.06; A/C		FB 6PK1835
			 ; →08.06; A/C ; 		
					538 0374 10
			16x		420 0063 10
			 11 mm		
			1x; 		428 0185 10
			1x; 		428 0186 10
		FAG	 right ↓ down; →09.07		821 0558 10
			 right ↓ down; 09.07→		821 0857 10
			 left ↓ down; →09.07		821 0557 10
			 left ↓ down; 09.07→		821 0855 10
				 Set	713 6307 90
			 84 mm		
			 80 mm	 Set	713 6307 80
			 right		818 0206 10
			 left		818 0205 10
			 ↑ up 		825 0167 10
			 ↑ up 		825 0280 10
			 ↓ down; 09.07→		825 0300 10
					840 0198 10
			right		840 0878 10
			left		840 0877 10





			<p>SCHAEFFLER</p>
--	---	--	-------------------

NISSAN

INTERSTAR (X70)



dCi 100
 G9U 650; (74kW)

04.06-

 	624 3476 34 530 0198 10 531 0548 10 532 0313 20 529 0428 10 529 0437 10 532 0364 20 534 0181 10 534 0317 10 535 0030 10 535 0081 10 544 0110 10 FB 7PK1795 FB 7PK1835 538 0374 10 420 0063 10 428 0185 10 428 0186 10	16x 11 mm 1x 1x
<p>FAG</p>	right ↓ down; →09.07 right ↓ down; 09.07→ left ↓ down; →09.07 left ↓ down; 09.07→ 16" 84 mm 15" 84 mm 16" 80 mm 15" 80 mm right left ↓ down; →09.07 ↑ up ↑ up ↓ down; 09.07→ right left	821 0558 10 821 0857 10 821 0557 10 821 0855 10 713 6307 90 713 6308 00 713 6307 80 713 6308 10 818 0206 10 818 0205 10 825 0166 10 825 0167 10 825 0280 10 825 0300 10 840 0198 10 840 0878 10 840 0877 10

dCi 100
 G9U 720; G9U 754; (74kW)

04.06-

 	PK5.3## PF6 PK5.#00 PK6.#00 624 3476 09 624 3476 33 624 3476 34 530 0198 10 531 0548 10 532 0313 20 529 0428 10 529 0437 10 532 0364 20 534 0181 10 534 0317 10 535 0030 10 535 0081 10 544 0110 10 FB 7PK1103 FB 7PK1145 FB 7PK1795 FB 7PK1835 538 0374 10 420 0063 10 428 0185 10	16x 11 mm 1x
--	---	--------------------





NISSAN

INTERSTAR (X70)

dCi 100
 G9U 720; G9U 754; (74kW)

04.06-

	1x;		428 0186 10
FAG	right ↓ down; →09.07		821 0558 10
	right ↓ down; 09.07→		821 0857 10
	left ↓ down; →09.07		821 0557 10
	left ↓ down; 09.07→		821 0855 10
	; 16 "	Set	713 6307 90
	; 15 "	Set	713 6308 00
	; 16 "	Set	713 6307 80
	; 15 "	Set	713 6308 10
	right		818 0206 10
	left		818 0205 10
	↑ up		825 0167 10
	↑ up		825 0280 10
	↓ down; 09.07→		825 0300 10
			840 0198 10
	right		840 0878 10
	left		840 0877 10

dCi 120
 G9U 720; G9U 724; G9U 750;
 (84kW)

04.02-

LUK			624 3476 09
	PF1 PK5.0## PK6.0##		624 3476 33
	PK5.3## PK6.3## PF6.0##		624 3476 34
			530 0198 10
			531 0548 10
			532 0313 20
	; →11.04; G9U 720 G9U 754; ; A/C		529 0432 10
	; →08.06; G9U 720 G9U 724; A/C ; ; # OE 6PK1835		529 0436 10
	; →08.06; G9U 720 G9U 724; A/C ; # OE 6PK1835		
	; →08.06		532 0364 20
	; →08.06; A/C		534 0181 10
	; →08.06; A/C ;		
	; →08.06; A/C ;		534 0317 10
	# F-560843.XX F-556602.XX F-229643.XX		535 0030 10
	# F-238512.XX		535 0081 10
	; →08.06; G9U 720 G9U 724; A/C ;		FB 6PK1148
	; A/C ; →09.03		FB 6PK1153
	; →08.06; A/C		FB 6PK1795
	; →08.06; A/C ;		
	; →08.06; A/C		FB 6PK1835
	; →08.06; A/C ;		
	; 10.03→; A/C ; PTO ; # OE 93186955 4416361		FB 7PK1103
	; 10.03→; A/C ; PTO ; # OE 9121108, 4405275		FB 7PK1145
	; 10.03→; A/C		FB 7PK1795
16x		538 0374 10	
11 mm		420 0063 10	
1x;		428 0185 10	
1x;		428 0186 10	
FAG	right ↓ down; →09.07		821 0558 10
	right ↓ down; 09.07→		821 0857 10
	left ↓ down; →09.07		821 0557 10
	left ↓ down; 09.07→		821 0855 10
	; 16 "	Set	713 6307 90
	; 15 "	Set	713 6308 00
	; 16 "	Set	713 6307 80
	; 15 "	Set	713 6308 10
	right		818 0206 10
	left		818 0205 10
	↑ up		825 0167 10
	↑ up		825 0280 10
	; 101,9 mm		771 0292 30



			<p>SCHAEFFLER</p>
--	--	--	--------------------------

NISSAN

INTERSTAR (X70)

<p>dCi 120 G9U 720; G9U 724; G9U 750; (84kW)</p>	<p>04.02-</p>	<p>FAG</p>	<p>↓ down; 09.07→ right left</p>	<p>825 0300 10 840 0198 10 840 0878 10 840 0877 10</p>
<p>dCi 120 G9U 724; G9U 750; (84kW)</p>	<p>07.02-08.06</p>	<p>LUK</p>	<p>PF1.000 PK5.000 PK6.000 PK5.3## PK6.3## PF6.0##</p>	<p>624 3476 09 624 3476 33 624 3476 34 530 0198 10 531 0548 10 532 0313 20 529 0436 10 532 0364 20 534 0181 10 534 0317 10 F-560843.XX F-556602.XX F-229643.XX F-238512.XX FB 6PK1148 FB 6PK1153 FB 6PK1795 FB 6PK1835 FB 7PK1103 FB 7PK1145 FB 7PK1795 538 0374 10 420 0063 10 428 0185 10 428 0186 10</p>
<p>dCi 120 G9U 720; G9U 724; G9U 750; (84kW)</p>	<p>08.03-</p>	<p>FAG</p>	<p>right ↓ down left ↓ down 16" 84 mm 15" 84 mm 16" 80 mm 15" 80 mm 101,9 mm right left ↓ down ↑ up ↑ up right left</p>	<p>821 0558 10 821 0557 10 713 6307 90 713 6308 00 713 6307 80 713 6308 10 771 0292 30 818 0206 10 818 0205 10 825 0166 10 825 0167 10 825 0280 10 840 0198 10 840 0878 10 840 0877 10</p>
		<p>LUK</p>	<p>PK5.3## PF6.0## PK5.0## PK6.0##</p>	<p>624 3476 09 624 3476 33 624 3476 34 530 0198 10 531 0548 10 532 0313 20 529 0432 10 529 0436 10 532 0364 20 534 0181 10 534 0317 10 F-560843.XX F-556602.XX F-229643.XX F-238512.XX FB 6PK1148</p>



			SCHAEFFLER
--	---	--	-------------------





NISSAN

INTERSTAR (X70)

































dCi 120
 G9U 720; G9U 724; G9U 750;
 (84kW)

08.03-



 ; A/C ; →09.03		FB 6PK1153
 ; →08.06; A/C		FB 6PK1795
 ; →08.06; A/C ; -e		
 ; →08.06; A/C		FB 6PK1835
 ; →08.06; A/C ; -e		
 ; 10.03→; A/C ; PTO ; # OE 93186955 4416361		FB 7PK1103
 ; 10.03→; A/C ; PTO ; # OE 9121108, 4405275		FB 7PK1145
 ; 10.03→; A/C		FB 7PK1795
		538 0374 10
		420 0063 10
16x		
 11 mm		
1x; 		428 0185 10
1x; 		428 0186 10





 right ↓ down; →09.07		821 0558 10
 right ↓ down; 09.07→		821 0857 10
 left ↓ down; →09.07		821 0557 10
 left ↓ down; 09.07→		821 0855 10
		Set 713 6307 90
 84 mm		Set 713 6307 80
		Set 713 6307 80
 80 mm		
 right		818 0206 10
 left		818 0205 10
 ↑ up 		825 0167 10
 ↑ up 		825 0280 10
 ↓ down; 09.07→		825 0300 10
		840 0198 10
 right		840 0878 10
 left		840 0877 10



























dCi 120
 G9U 650; (88kW)







08.06-



































		624 3476 09
 PF6.0##		624 3476 34



		530 0198 10
		531 0548 10
		532 0313 20
 ; →03.11; A/C ; -e		529 0428 10
 ; →03.11; A/C ; # OE 7PK1835		529 0437 10
 ; →03.11; A/C ; -e ; # OE 7PK1835		
 ; →03.11		532 0364 20
 ; →03.11; A/C		534 0181 10
 ; →03.11; A/C ; -e		
 ; →03.11; A/C ; -e		534 0317 10
 # F-560843.XX F-556602.XX F-229643.XX		535 0030 10
 # F-238512.XX		535 0081 10
 ; OPTION		544 0110 10
 ; A/C		FB 7PK1795
 ; →03.11; A/C		FB 7PK1835
 ; →03.11; A/C ; -e		

		538 0374 10
16x		420 0063 10
 11 mm		
1x; 		428 0185 10
1x; 		428 0186 10



 right ↓ down; →09.07		821 0558 10
 right ↓ down; 09.07→		821 0857 10
 left ↓ down; →09.07		821 0557 10
 left ↓ down; 09.07→		821 0855 10
		Set 713 6307 90
 84 mm		Set 713 6307 80
		Set 713 6307 80
 80 mm		
 right		818 0206 10
 left		818 0205 10
 ↑ up 		825 0167 10
 ↑ up 		825 0280 10
 ↓ down; 09.07→		825 0300 10
		840 0198 10
 right		840 0878 10
 left		840 0877 10



			<p>SCHAEFFLER</p>
--	---	--	--------------------------























NISSAN

INTERSTAR (X70)

















dCi 120
 G9U 650; (88kW)

09.06-



		624 3476 09
PF6.0##		624 3476 34
PF6		624 3476 34
		530 0198 10
		531 0548 10
		532 0313 20
		529 0428 10
		529 0437 10
		532 0364 20
		534 0181 10
		534 0181 10
		534 0317 10
		535 0030 10
		535 0081 10
		544 0110 10
		FB 7PK1795
		FB 7PK1795
		FB 7PK1835
		538 0374 10
		420 0063 10
		428 0185 10
		428 0186 10



















right ↓ down; →09.07		821 0558 10
right ↓ down; 09.07→		821 0857 10
left ↓ down; →09.07		821 0557 10
left ↓ down; 09.07→		821 0855 10
		713 6307 90
		713 6308 00
		713 6307 80
		713 6308 10
		818 0206 10
		818 0205 10
		825 0166 10
		825 0167 10
		825 0280 10
		825 0300 10
		840 0198 10
		840 0878 10
		840 0877 10

dCi 150
 G9U 632; (107kW)

08.06-































































































































		624 3476 09
PF6.0##		624 3476 34
		530 0198 10
		531 0548 10
		532 0313 20
		529 0437 10
		532 0364 20
		534 0181 10
		534 0317 10
		535 0030 10
		FB 7PK1113
		FB 7PK1795
		FB 7PK1835
		538 0374 10
		420 0063 10
		428 0185 10
		428 0186 10



			SCHAEFFLER
--	---	--	-------------------

NISSAN

INTERSTAR (X70)



























dCi 150 G9U 632; (107kW)	08.06-	FAG	 right ↓ down; →09.07		821 0558 10			
			 right ↓ down; 09.07→		821 0857 10			
			 left ↓ down; →09.07		821 0557 10			
			 left ↓ down; 09.07→		821 0855 10			
			 84 mm		713 6307 90			
			 80 mm		713 6307 80			
			 right		818 0206 10			
			 left		818 0205 10			
			 ↑ up 		825 0167 10			
			 ↑ up 		825 0280 10			
			 ↓ down; 09.07→		825 0300 10			
					840 0198 10			
			 right		840 0878 10			
			 left		840 0877 10			
					624 3476 09			
			dCi 150 G9U 632; (107kW)	09.06-	LUK			624 3476 34
						 PF6.0##		530 0198 10
		531 0548 10						
 ; →03.11; A/C ; e ; # OE 7PK1835		532 0313 20						
 ; →03.11		529 0437 10						
 ; →03.11; A/C		532 0364 20						
 ; →03.11; A/C ; e		534 0181 10						
 ; →03.11; A/C ; e		534 0317 10						
 # F-560843.XX F-556602.XX F-229643.XX		535 0030 10						
 ; →03.11; A/C ; e		FB 7PK1113						
 ; A/C ; PTO ; # OE 8200833558		FB 7PK1795						
 ; A/C		FB 7PK1835						
 ; →03.11; A/C ; e		538 0374 10						
16x		420 0063 10						
 11 mm		428 0185 10						
1x; 		428 0186 10						
1x; 		821 0558 10						
FAG	FAG	 right ↓ down; →09.07					821 0857 10	
		 right ↓ down; 09.07→					821 0557 10	
		 left ↓ down; →09.07					821 0855 10	
		 left ↓ down; 09.07→					713 6307 90	
		 ; 16 "					713 6308 00	
		 84 mm					713 6307 80	
		 ; 15 "		713 6308 10				
		 84 mm		713 6307 80				
		 ; 16 "		713 6308 10				
		 80 mm		713 6308 10				
		 ; 15 "		818 0206 10				
		 80 mm		818 0205 10				
		 right		825 0166 10				
		 left		825 0167 10				
		 ↓ down; →09.07		825 0280 10				
		 ↑ up 		825 0300 10				
		 ↑ up 		840 0198 10				
 ↓ down; 09.07→		840 0878 10						
		840 0877 10						
dCi 140 ZD30; (100kW)	11.03-	LUK			624 3476 34			
			 # F-228751.XX		535 0053 10			
					538 0384 10			
			FAG	FAG	 right ↓ down; →09.07		821 0558 10	
					 right ↓ down; 09.07→		821 0857 10	
					 left ↓ down; →09.07		821 0557 10	
					 left ↓ down; 09.07→		821 0855 10	
					 84 mm		713 6307 90	
					 ; 16 "		713 6307 90	
					 84 mm			



			SCHAEFFLER
--	---	--	-------------------

NISSAN

























































INTERSTAR (X70)

dCi 140 ZD30; (100kW)	11.03-	FAG	 ;  15"		713 6308 00
			 84 mm		713 6307 80
			 ;  16"		713 6307 80
			 80 mm		713 6307 80
			 80 mm		713 6308 10
			 ;  15"		713 6308 10
			 80 mm		713 6308 10
			 101,9 mm		771 0292 30
			right		818 0206 10
			left		818 0205 10
			↓ down; →09.07		825 0166 10
			↑ up 		825 0167 10
			↑ up 		825 0280 10
			↓ down; 09.07→		825 0300 10

NT400 CABSTAR (F24F)

28.12, 32.12, 35.12 (F91AN) 35.14, 45.14 35.15, 45.15 YD25K3LD-5HO; YD25K3LD-5LO; YD25K3LD-5MI; (90-107kW)	01.14-				531 0931 10
					FB 7PK1753































































































NV200

e- (ME0) e-NV (ME0) EM57; (80kW)	05.14-	FAG			713 6330 30			
					713 6330 40			
			 ↔		818 0474 10			
			right		840 1189 10			
			left		840 1190 10			
			 ↔		840 1223 10			
			1.5 dci (M20, M20M) K9K 400; K9K 608; K9K 628; (63kW)	02.10-	LUK	EURO 5		622 3096 33
						07.15→; EURO 6 ;  12,7		622 3429 34
						07.15→; EURO 6 ;  15,8		622 3429 34
						→10.13		530 0197 10
10.13→		530 0607 10						
OPTION		530 0197 30						
10.10→01.13; EURO 4		530 0197 31						
→01.13; EURO 5		530 0197 32						
10.13→		530 0607 30						
		531 0547 10						
		531 0906 10						
 ; A/C		529 0009 10						
 ; A/C		529 0165 10						
 ; +  ; A/C		529 0224 10						
 ; A/C		534 0269 10						
A/C; 07.10→		535 0102 10						
## F-550213.11 F-550213/.02/.08/.09		535 0105 10						
## F-552973.XX F-550181.XX F-557755.XX		535 0154 10						
## F-550883.XX		544 0054 10						
		544 0090 10						
		544 0054 20						
		544 0090 20						
 ; A/C		FB 6PK1200						
		538 0047 10						
1x; EURO 4		428 0163 10						
1x; EURO 5 EURO 6		428 0198 10						
FAG			713 6330 30					
			713 6330 40					
	 ↔		818 0490 10					
	right		840 1189 10					
	left		840 1190 10					
	 ↔		840 1223 10					
1.5 dci (M20, M20M, M20K, M20KK) K9K 400; K9K 608; K9K 628; (63kW)	07.10-	LUK	EURO 5		622 3096 33			
			07.15→; EURO 6 ;  12,7		622 3429 34			



			SCHAEFFLER
--	--	--	-------------------

NISSAN





















































































NV200							
1.5 dci (M20, M20M, M20K, M20KK) K9K 400; K9K 608; K9K 628; (63kW)	07.10-		→10.13		530 0197 10		
			10.13→		530 0607 10		
			10.10→01.13; EURO 4		530 0197 31		
			→01.13; EURO 5		530 0197 32		
			10.13→		530 0607 30		
					531 0547 10		
					531 0906 10		
					529 0009 10		
					529 0165 10		
					529 0224 10		
					534 0269 10		
					535 0102 10		
					535 0105 10		
					535 0154 10		
				544 0054 10			
				544 0090 10			
				544 0054 20			
				544 0090 20			
				FB 6PK1200			
				538 0047 10			
		1x; EURO 4		428 0163 10			
		1x; EURO 5 EURO 6		428 0198 10			
		FAG				Set	713 6330 30
						Set	713 6330 40
							818 0490 10
						right	840 1189 10
						left	840 1190 10
							840 1223 10
1.5 dci (M20, M20M) K9K 892; (66kW)	04.11-		incl. 		600 0197 00		
					623 3553 33		
			incl. 		415 0400 10		
				→10.13		530 0197 10	
				10.13→		530 0607 10	
				→01.13; EURO 4		530 0197 31	
				→01.13; EURO 5		530 0197 32	
				10.13→		530 0607 30	
						531 0547 10	
						531 0906 10	
						529 0009 10	
						529 0117 10	
						529 0165 10	
						529 0165 10	
						529 0224 10	
						529 0224 10	
						534 0269 10	
				535 0102 10			
				535 0105 10			
				535 0154 10			
				544 0054 10			
				544 0090 10			
				544 0054 20			
				544 0090 20			
				FB 6PK1200			
				538 0047 10			
		1x; EURO 5		428 0198 10			
		FAG				Set	713 6330 30
				Set	713 6330 40		
					818 0490 10		
				right	840 1189 10		
				left	840 1190 10		
					840 1223 10		
1.5 dci (M20, M20M) K9K 636; K9K 646; (81kW)	04.11-		incl. 		600 0197 00		
					623 3553 33		
			incl. 		415 0400 10		
				→10.13		530 0197 10	
				10.13→		530 0607 10	
						530 0197 31	



























			SCHAEFFLER
--	--	--	-------------------

NISSAN

NV200

1.5 dci (M20, M20M) K9K 636; K9K 646; (81kW)	04.11-		→10.13		530 0197 32	
			10.13→		530 0607 30	
					531 0547 10	
					531 0906 10	
			 ; A/C		529 0009 10	
			 ; A/C		529 0165 10	
			 ; +  ; A/C		529 0224 10	
					534 0269 10	
			Part # F-550213.11 F-550213/.02/.08/.09		535 0102 10	
			Part # F-552973.XX F-550181.XX F-557755.XX		535 0105 10	
		Part # F-550883.XX		535 0154 10		
				544 0054 10		
				544 0090 10		
				544 0090 10		
				544 0054 20		
				544 0090 20		
				544 0090 20		
		 ; A/C		FB 6PK1200		
		1x; EURO 5		538 0047 10		
				428 0198 10		
FAG			Set	713 6330 30		
			Set	713 6330 40		
				818 0490 10		
			right	840 1189 10		
			left	840 1190 10		
				840 1223 10		
				622 3199 33		
				529 0272 10		
1.6 16V (M20, M20M) HR16DE; (81kW)	02.10-				529 0272 10	
					532 0780 10	
			 ;  BM M20; A/C		FB 7PK1145	
					538 0383 10	
		FAG			Set	713 6330 30
					Set	713 6330 40
						818 0490 10
					right	840 1189 10
					left	840 1190 10
						840 1223 10
1.6 16V (M20, M20M) HR16DE; (81kW)	07.10-				622 3199 33	
					529 0272 10	
			 ;  BM M20M; A/C		532 0780 10	
					FB 7PK1145	
		FAG				538 0383 10
					Set	713 6330 30
					Set	713 6330 40
						818 0490 10
					right	840 1189 10
					left	840 1190 10
			840 1223 10			























































































































NV300 Box (X82)

1.6 dci 120 1.6 dci 95 R9M 413; R9M 415; (70-89kW)	09.16-		SAC		624 3930 33
					415 0796 10
					529 0246 10
			Part # F-552305.XX		535 0153 10
			Part # F-610567		535 0344 10
					538 0399 10
			16x		420 0086 10
			 12 mm		
			16x		422 0078 10
		FAG			Set
				818 0207 10	
				840 0274 10	
			right	840 0880 10	
			left	840 0879 10	
1.6 dci 125 1.6 dci 145 R9M 452; (92-107kW)	09.16-		SAC		624 3930 33
					415 0796 10



			SCHAEFFLER
--	--	--	-------------------

NISSAN





















































































NV300 Box (X82)						
1.6 dci 125 1.6 dci 145 R9M 452; (92-107kW)	09.16-		## F-552305.XX		535 0153 10	
			## F-610567		535 0344 10	
			16x		538 0399 10	
			 12 mm		420 0086 10	
			16x		422 0078 10	
		FAG			Set	713 6451 90
						818 0207 10
						840 0274 10
						840 0880 10
						840 0879 10
NV300 Kombi (X82)						
1.6 dci 95 R9M 413; (70kW)	09.16-		SAC		624 3930 33	
				415 0796 10		
			## F-552305.XX		529 0246 10	
			## F-610567		535 0153 10	
			16x		535 0344 10	
				538 0399 10		
				420 0086 10		
			16x		422 0078 10	
				420 0086 10		
			16x		422 0078 10	
FAG			Set	713 6451 90		
				818 0207 10		
				840 0274 10		
				840 0880 10		
				840 0879 10		
1.6 dCi 125 1.6 dCi 145 R9M 452; (92-107kW)	09.16-		SAC		624 3930 33	
				415 0796 10		
			## F-552305.XX		535 0153 10	
			## F-610567		535 0344 10	
			16x		538 0399 10	
				420 0086 10		
				422 0078 10		
			16x		420 0086 10	
				422 0078 10		
			16x		422 0078 10	
FAG			Set	713 6451 90		
				818 0207 10		
				840 0274 10		
				840 0880 10		
				840 0879 10		
1.6 dci 125 R9M 452; (92kW)	09.16-		SAC		624 3930 33	
				415 0796 10		
			## F-552305.XX		535 0153 10	
			## F-610567		535 0344 10	
			16x		538 0399 10	
				420 0086 10		
				422 0078 10		
			16x		420 0086 10	
				422 0078 10		
			16x		422 0078 10	
FAG			Set	713 6451 90		
				818 0207 10		
				840 0274 10		
				840 0880 10		
				840 0879 10		
1.6 dci 145 R9M 452; (107kW)	09.16-		## F-552305.XX		535 0153 10	
			## F-610567		535 0344 10	
			16x		538 0399 10	
				420 0086 10		
			16x		422 0078 10	
		FAG			Set	713 6451 90
						818 0207 10
						840 0274 10
						840 0880 10
						840 0879 10



			SCHAEFFLER
--	--	--	-------------------

NISSAN









































































NV400

dCi 100 M9T 670; M9T 672; M9T 676; (74kW)	11.11-05.14		M9T 670 M9T 676 PF6.0## incl.  ; incl.  ; SAC		600 0235 00
			M9T 670 M9T 676; PF6 M9T 670 M9T 676; SEMI; PA0 SAC		626 3049 09
			M9T 670 M9T 676 PF6.0## SAC		626 3049 33
			M9T 670 M9T 676 incl. 		415 0485 10
					529 0317 10
			 ; A/C		529 0353 10
					532 0534 10
					534 0281 10
			F-236675.XX F-561464.XX		535 0080 10
			F-552305.XX		535 0153 10
			 ; A/C		FB 7PK1973
					538 0397 10
			16x  12 mm		420 0086 10
			16x		422 0078 10
			1x		558 0060 10
			1x		559 0172 10
			1x		559 0172 30
			FAG	right	
		left			821 0868 10
					713 6450 40
		90 mm			713 6450 50
					818 0482 10
		80 mm			818 0475 10
		right			825 0333 10
		left			825 0332 10
					840 0394 10
		right			840 1143 10
		left		840 1142 10	
dCi 100 M9T 670; M9T 672; M9T 676; (74kW)	11.11-06.14		M9T 670 M9T 676 PF6.0## incl.  ; incl.  ; SAC		600 0235 00
			M9T 670 M9T 676; PF6 M9T 670 M9T 676; SEMI; PA0 SAC		626 3049 09
			M9T 670 M9T 676 PF6.0## SAC		626 3049 33
			M9T 670 M9T 676 incl. 		415 0485 10
					529 0317 10
			 ; A/C		529 0353 10
			 ; →01.14; A/C		532 0534 10
					534 0281 10
			F-236675.XX F-561464.XX		535 0080 10
			F-552305.XX		535 0153 10
			 ; A/C		FB 7PK1973
					538 0397 10
			16x  12 mm		420 0086 10
			16x		422 0078 10
			1x		558 0060 10
			1x		559 0172 10
			1x		559 0172 30
			FAG	right	
		left			821 0868 10
					713 6450 40
		90 mm			713 6450 50
				818 0482 10	
		80 mm		818 0475 10	
		right		825 0333 10	
		left		825 0332 10	
				840 0394 10	
		right		840 1143 10	
		left		840 1142 10	



			SCHAEFFLER
--	--	--	-------------------

NISSAN





























































NV400						
dCi 100 M9T 670; M9T 672; M9T 676; (74kW)	11.11-06.14	FAG	 ↔ 818 0475 10			
			 right 825 0333 10			
			 left 825 0332 10			
			 ↔ 840 0394 10			
			 right 840 1143 10			
			 left 840 1142 10			
			dCi 110 M9T 870; (81kW)	06.14-	LUK	 PF6 incl.  ; incl.  ; SAC 600 0235 00
						 PF6 PA0 SAC 626 3049 09
						 PF6 SAC 626 3049 33
						 incl.  415 0485 10
	 ; für Fahrzeuge mit Extra Heizung;  529 0352 10					
	 ;  A/C 529 0353 10					
	 # F-236675.XX F-561464.XX 535 0080 10					
	 # F-552305.XX 535 0153 10					
	 538 0397 10					
	 16x  12 mm 16x  420 0086 10					
FAG	 right 821 0865 10					
	 left 821 0868 10					
	  90 mm 713 6450 40					
	  80 mm 713 6450 50					
	 ↔ 818 0482 10					
	 ↔ 818 0475 10					
	 right 825 0333 10					
	 left 825 0332 10					
	 ↔ 840 0394 10					
	 right 840 1143 10					
	 left 840 1142 10					
	dCi 110 M9T 870; (81kW)	06.14-06.16	LUK	 M9T 870 SAC 626 3049 09		
				 MRT 870; G6 ;  PF6 SAC 626 3049 33		
				 ;  529 0317 10		
 ; für Fahrzeuge mit Extra Heizung;  529 0352 10						
 ;  A/C 529 0353 10						
 532 0534 10						
 # F-236675.XX F-561464.XX 535 0080 10						
 # F-552305.XX 535 0153 10						
 ;  FB 7PK1685						
 538 0397 10						
FAG	 right 821 0865 10					
	 left 821 0868 10					
	  90 mm 713 6450 40					
	  80 mm 713 6450 50					
	 ↔ 818 0482 10					
	 ↔ 818 0475 10					
	 right 825 0333 10					
	 left 825 0332 10					
	 ↔ 840 0394 10					
	 right 840 1143 10					
	 left 840 1142 10					
	dCi 110 M9T 870; (81kW)	06.14-09.16	LUK	 incl.  ; incl.  ; SAC 600 0235 00		
				 SAC 626 3049 09		
				 PF6 SAC 626 3049 33		
 incl. 415 0485 10						
			; für Fahrzeuge mit Extra Heizung; 529 0352 10			
			; A/C 529 0353 10			
			# F-236675.XX F-561464.XX 535 0080 10			



			SCHAEFFLER
--	--	--	-------------------

NISSAN













































































NV400

<p>dCi 110 M9T 870; (81kW)</p>	<p>06.14-09.16</p>		<p>№# F-552305.XX</p>		535 0153 10
			<p>16x 12 mm</p>		538 0397 10
<p>dCi 125 M9T 670; M9T 672; M9T 676; (92kW)</p>	<p>11.11-06.16</p>		<p>16x</p>		420 0086 10
			<p>right</p>		422 0078 10
			<p>left</p>		821 0865 10
			<p>90 mm</p>		821 0868 10
			<p>80 mm</p>		Set 713 6450 40
			<p>↔</p>		Set 713 6450 50
			<p>↔</p>		818 0482 10
			<p>right</p>		818 0475 10
			<p>left</p>		825 0333 10
			<p>↔</p>		825 0332 10
			<p>right</p>		840 0394 10
			<p>left</p>		840 1143 10
			<p>↔</p>		840 1142 10
			<p>M9T 670 M9T 676; PF6 incl. ○; incl. ■■■■■; SAC</p>		600 0235 00
			<p>M9T 670 M9T 676; MANU; PF6</p>		626 3049 09
			<p>M9T 670 M9T 676; SEMI; PA0 SAC</p>		626 3049 33
			<p>M9T 670 M9T 676; MANU; PF6; № 0## SAC</p>		415 0485 10
			<p>M9T 670 M9T 676 incl. ■■■■■</p>		529 0317 10
<p>■; A/C</p>		529 0353 10			
<p>■; →01.14; A/C</p>		532 0534 10			
<p>■</p>		534 0281 10			
<p>№# F-236675.XX F-561464.XX</p>		535 0080 10			
<p>№# F-552305.XX</p>		535 0153 10			
<p>■; A/C</p>		FB 7PK1973			
<p>16x</p>		538 0397 10			
<p>12 mm</p>		420 0086 10			
<p>16x</p>		422 0078 10			
<p>1x</p>		KIT 558 0060 10			
<p>1x</p>		KIT 559 0172 10			
<p>1x</p>		KIT 559 0172 30			
<p>FAG</p>	<p>right</p>		<p>left</p>		821 0865 10
			<p>left</p>		821 0868 10
			<p>90 mm</p>		Set 713 6450 40
			<p>80 mm</p>		Set 713 6450 50
			<p>↔</p>		818 0482 10
			<p>↔</p>		818 0475 10
			<p>right</p>		825 0333 10
			<p>left</p>		825 0332 10
			<p>↔</p>		840 0394 10
			<p>right</p>		840 1143 10
			<p>left</p>		840 1142 10
			<p>dCi 125 RWD M9T 686; M9T 690; M9T 692; M9T 696; M9T 698; M9T 870; M9T 896; (92kW)</p>	<p>11.11-06.16</p>	
<p>M9T 692 M9T 698 incl. ■■■■■</p>		415 0490 10			
<p>■</p>		529 0317 10			
<p>■; A/C</p>		529 0353 10			
<p>■; →01.14; A/C</p>		532 0534 10			
<p>■</p>		534 0281 10			
<p>№# F-236675.XX F-561464.XX</p>		535 0080 10			
<p>№# F-552305.XX</p>		535 0153 10			
<p>■; A/C</p>		FB 7PK1973			
<p>16x</p>		420 0086 10			
<p>12 mm</p>		422 0078 10			
<p>16x</p>		422 0078 10			
<p>1x</p>		KIT 558 0060 10			
<p>1x</p>		KIT 559 0172 10			



			SCHAEFFLER
--	--	--	-------------------































































NISSAN

NISSAN						
NV400						
dCi 125 RWD M9T 686; M9T 690; M9T 692; M9T 696; M9T 698; M9T 870; M9T 896; (92kW)	11.11-06.16	 FAG	1x  559 0172 30			
			 right  821 0865 10			
			 left  821 0868 10			
			 90 mm  713 6450 40			
			  713 6450 30			
			  713 6451 60			
			 ↔  818 0482 10			
			 ↔  818 0475 10			
			 ↔  818 0492 10			
			 right  825 0333 10			
			 left  825 0332 10			
			 ↔  840 0394 10			
			 right  840 1143 10			
			 left  840 1142 10			
			dCi 125 M9T 670; M9T 672; M9T 676; (92kW)	11.11-09.16		M9T 670 M9T 676  600 0235 00
						PF6.0## incl. ○; incl. ■■■■■; SAC  600 0235 00
						M9T 670 M9T 676  626 3049 09
						PF6 incl. ○; incl. ■■■■■; SAC  626 3049 33
M9T 670 M9T 676; PF6  626 3049 33						
M9T 670 M9T 676; SEMI ; PA0 SAC  415 0485 10						
M9T 670 M9T 676  529 0317 10						
PF6.0## SAC  529 0353 10						
M9T 670 M9T 676  532 0534 10						
PF6 SAC  534 0281 10						
M9T 670 M9T 676  535 0080 10						
incl. ■■■■■  535 0153 10						
A/C  FB 7PK1973						
A/C  538 0397 10						
16x  420 0086 10						
12 mm  422 0078 10						
16x  558 0060 10						
1x  559 0172 10						
1x  559 0172 30						
dCi 125 RWD M9T 686; M9T 690; M9T 692; M9T 696; M9T 698; M9T 870; M9T 896; (92kW)	11.11-09.16	 FAG	M9T 692 M9T 698  626 3050 00			
			M9T 692 M9T 698  415 0490 10			
			incl. ■■■■■  529 0317 10			
			A/C  529 0353 10			
			A/C  532 0534 10			
			A/C  534 0281 10			
			F-236675.XX F-561464.XX  535 0080 10			
			right  821 0865 10			
			left  821 0868 10			
			 90 mm  713 6450 40			
			 80 mm  713 6450 50			
			 ↔  818 0482 10			
			 ↔  818 0475 10			
			 right  825 0333 10			
			 left  825 0332 10			
			 ↔  840 0394 10			
			 right  840 1143 10			
			 left  840 1142 10			



			<p>SCHAEFFLER</p>
--	--	--	--------------------------



























































NISSAN

NV400		11.11-09.16		FAG	
<p>dCi 125 RWD M9T 686; M9T 690; M9T 692; M9T 696; M9T 698; M9T 870; M9T 896; (92kW)</p>	<p>11.11-09.16</p>		<p>№# F-552305.XX</p>		535 0153 10
			<p>16x</p>		FB 7PK1973
			<p>12 mm</p>		420 0086 10
			<p>16x</p>		422 0078 10
			<p>1x</p>		558 0060 10
			<p>1x</p>		559 0172 10
			<p>1x</p>		559 0172 30
			<p>right</p>		821 0865 10
			<p>left</p>		821 0868 10
			<p>90 mm</p>		713 6450 40
			<p>90 mm</p>		713 6450 30
			<p>90 mm</p>		713 6451 60
			<p>↔</p>		818 0482 10
			<p>↔</p>		818 0475 10
			<p>↔</p>		818 0492 10
<p>right</p>		825 0333 10			
<p>left</p>		825 0332 10			
<p>↔</p>		840 0394 10			
<p>right</p>		840 1143 10			
<p>left</p>		840 1142 10			
<p>dCi 130 M9T; (96kW)</p>	<p>06.16-</p>		<p>SAC</p>		626 3049 33
			<p>09.16→; A/C</p>		529 0355 10
			<p>09.16→; A/C</p>		529 0356 10
			<p>09.16→</p>		532 0534 10
			<p>09.16→; A/C</p>		532 0668 10
			<p>09.16→</p>		534 0281 10
			<p>№# F-236675.XX F-561464.XX</p>		535 0080 10
			<p>№# F-552305.XX</p>		535 0153 10
			<p>16x</p>		420 0086 10
			<p>12 mm</p>		422 0078 10
			<p>16x</p>		821 0865 10
			<p>right</p>		821 0868 10
			<p>left</p>		713 6450 40
			<p>90 mm</p>		713 6450 50
			<p>80 mm</p>		818 0482 10
<p>↔</p>		818 0475 10			
<p>↔</p>		840 0394 10			
<p>↔</p>		840 1143 10			
<p>right</p>		840 1142 10			
<p>left</p>		626 3050 00			
<p>dCi 130 RWD M9T; (96kW)</p>	<p>06.16-</p>		<p>incl. </p>		415 0490 10
			<p>09.16→; A/C</p>		529 0354 10
			<p>09.16→; A/C</p>		529 0356 10
			<p>09.16→</p>		532 0534 10
			<p>09.16→; A/C</p>		532 0668 10
			<p>09.16→</p>		534 0281 10
			<p>№# F-236675.XX F-561464.XX</p>		535 0080 10
			<p>№# F-552305.XX</p>		535 0153 10
			<p>16x</p>		420 0086 10
			<p>12 mm</p>		422 0078 10
			<p>16x</p>		821 0865 10
			<p>right</p>		821 0868 10
			<p>left</p>		713 6450 40
			<p>90 mm</p>		713 6450 30
			<p>90 mm</p>		713 6451 60
<p>↔</p>		818 0492 10			
<p>↔</p>		840 0394 10			
<p>right</p>		840 1143 10			
<p>left</p>		840 1142 10			



			SCHAEFFLER
--	--	--	-------------------





























































































































NISSAN

NV400			
dCi 130 M9T; (96kW)	09.16-	<p>LUK M9T 704 SAC</p> <p>INA ; A/C ; A/C # F-236675.XX F-561464.XX # F-552305.XX 16x 12 mm 16x</p> <p>FAG right left 90 mm 80 mm ↔ ↔ ↔ right left</p>	<p> 626 3049 33</p> <p> 529 0355 10</p> <p> 529 0356 10</p> <p> 532 0534 10</p> <p> 532 0668 10</p> <p> 534 0281 10</p> <p> 535 0080 10</p> <p> 535 0153 10</p> <p> 420 0086 10</p> <p> 422 0078 10</p> <p> 821 0865 10</p> <p> 821 0868 10</p> <p> Set 713 6450 40</p> <p> Set 713 6450 50</p> <p> 818 0482 10</p> <p> 818 0475 10</p> <p> 840 0394 10</p> <p> 840 1143 10</p> <p> 840 1142 10</p>
dCi 130 RWD M9T; (96kW)	09.16-	<p>INA ; A/C ; A/C # F-236675.XX F-561464.XX # F-552305.XX 16x 12 mm 16x</p> <p>FAG right left 90 mm ; ; ; ; 90 mm ; ; ↔ ↔ right left</p>	<p> 529 0354 10</p> <p> 529 0356 10</p> <p> 532 0534 10</p> <p> 532 0668 10</p> <p> 534 0281 10</p> <p> 535 0080 10</p> <p> 535 0153 10</p> <p> 420 0086 10</p> <p> 422 0078 10</p> <p> 821 0865 10</p> <p> 821 0868 10</p> <p> Set 713 6450 40</p> <p> Set 713 6450 30</p> <p> Set 713 6451 60</p> <p> 818 0492 10</p> <p> 840 0394 10</p> <p> 840 1143 10</p> <p> 840 1142 10</p>
dCi 140 M9T; M9T 702; (100kW)	06.14-06.16	<p>LUK PF6 SAC SAC</p> <p>INA # F-236675.XX F-561464.XX # F-552305.XX 16x 12 mm 16x</p> <p>FAG right left 90 mm 80 mm ↔ ↔ right left ↔ right left</p>	<p> 626 3049 09</p> <p> 626 3049 33</p> <p> 535 0080 10</p> <p> 535 0153 10</p> <p> 538 0397 10</p> <p> 420 0086 10</p> <p> 422 0078 10</p> <p> 821 0865 10</p> <p> 821 0868 10</p> <p> Set 713 6450 40</p> <p> Set 713 6450 50</p> <p> 818 0482 10</p> <p> 818 0475 10</p> <p> 825 0333 10</p> <p> 825 0332 10</p> <p> 840 0394 10</p> <p> 840 1143 10</p> <p> 840 1142 10</p>
dCi 140 RWD M9T 696; M9T 698; (100kW)	06.14-09.16	<p>LUK</p> <p>incl. </p>	<p> 626 3050 00</p> <p> 415 0490 10</p>



			SCHAEFFLER
--	--	--	-------------------

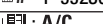





























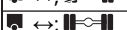

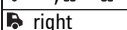
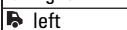

























































































NISSAN

NV400								
dCi 140 RWD M9T 696; M9T 698; (100kW)	06.14-09.16	 FAG	 ; -e A/C		529 0353 10			
			 # F-236675.XX F-561464.XX		535 0080 10			
			 # F-552305.XX		535 0153 10			
			16x		420 0086 10			
			 12 mm					
			16x		422 0078 10			
			 right		821 0865 10			
			 left		821 0868 10			
					713 6450 40			
			 90 mm		713 6450 30			
			 ; 		713 6451 60			
			 90 mm					
			 ↔		818 0482 10			
			 ↔ ; 		818 0475 10			
			 ↔ ; 		818 0492 10			
			 right		825 0333 10			
			 left		825 0332 10			
			 ↔		840 0394 10			
			 right		840 1143 10			
 left		840 1142 10						
dCi 140 M9T 702; (100kW)	06.14-09.16	 FAG	SAC		626 3049 33			
			 # F-236675.XX F-561464.XX		535 0080 10			
			 # F-552305.XX		535 0153 10			
					538 0397 10			
			 right		821 0865 10			
			 left		821 0868 10			
					713 6450 40			
			 90 mm		713 6450 50			
			 80 mm					
			 ↔		818 0482 10			
			 ↔		818 0475 10			
			 right		825 0333 10			
			 left		825 0332 10			
			 ↔		840 0394 10			
			 right		840 1143 10			
			 left		840 1142 10			
			dCi 140 M9T 696; M9T 698; (100kW)	06.14-09.16	 FAG	 ; -e A/C		529 0353 10
						 # F-236675.XX F-561464.XX		535 0080 10
						 # F-552305.XX		535 0153 10
		538 0397 10						
16x		420 0086 10						
 12 mm								
16x		422 0078 10						
 right		821 0865 10						
 left		821 0868 10						
		713 6450 40						
 90 mm		713 6450 50						
 80 mm								
 ↔		818 0482 10						
 ↔		818 0475 10						
 right		825 0333 10						
 left		825 0332 10						
 ↔		840 0394 10						
 right		840 1143 10						
 left		840 1142 10						
2.3 dCi 145 RWD M9T 694; M9T 696; M9T 698; (107kW)	11.11-02.14	 	M9T 694 M9T 698		626 3050 00			
			M9T 694 M9T 698		415 0490 10			
			incl. 					
					529 0317 10			
			 ; A/C		529 0353 10			
			 ; →01.14; A/C		532 0534 10			
					534 0281 10			
			 # F-236675.XX F-561464.XX		535 0080 10			
			 # F-552305.XX		535 0153 10			
			 ; A/C		FB 7PK1973			



			SCHAEFFLER
--	---	--	-------------------





































































































































NISSAN

NV400									
2.3 dCi 145 RWD M9T 694; M9T 696; M9T 698; (107kW)	11.11-02.14		16x  12 mm		420 0086 10				
			16x		422 0078 10				
			1x		558 0060 10				
			1x		559 0172 10				
			1x		559 0172 30				
		FAG		 right		821 0865 10			
				 left		821 0868 10			
				 90 mm		713 6450 40			
				 ;  90 mm		713 6450 30			
				 90 mm		713 6451 60			
				 ↔		818 0482 10			
				 ↔ ;  90 mm		818 0475 10			
				 ↔ ;  90 mm		818 0492 10			
				 right		825 0333 10			
				 left		825 0332 10			
				 ↔		840 0394 10			
				 right		840 1143 10			
				 left		840 1142 10			
				dCi 145 M9T 678; M9T 680; M9T 706; (107kW)	11.11-02.14		 PF6.0## incl.  ; incl.  ; SAC		600 0235 00
							 PF6		626 3049 09
 SEMI ;  PA0 SAC		626 3049 33							
 PF6 SAC		626 3049 33							
 PF6.0## SAC		626 3049 33							
 incl. 		415 0485 10							
						529 0317 10			
		 ; A/C				529 0353 10			
		 ;  M9T 706; A/C				529 0355 10			
		 ; →01.14; A/C				532 0534 10			
						534 0281 10			
		 # F-236675.XX F-561464.XX				535 0080 10			
		 # F-552305.XX				535 0153 10			
		 ; A/C				FB 7PK1973			
						538 0397 10			
		 16x  12 mm				420 0086 10			
		16x				422 0078 10			
		1x				558 0060 10			
		1x				559 0172 10			
		1x				559 0172 30			
FAG		 right		821 0865 10					
		 left		821 0868 10					
		 90 mm		713 6450 40					
		 80 mm		713 6450 50					
		 ↔		818 0482 10					
		 ↔		818 0475 10					
		 right		825 0333 10					
		 left		825 0332 10					
		 ↔		840 0394 10					
		 right		840 1143 10					
 left		840 1142 10							
dCi 145 M9T 678; M9T 680; M9T 706; (107kW)	11.11-06.16		 PF6 incl.  ; incl.  ; SAC		600 0235 00				
			 MANU ;  PF6		626 3049 09				
			 SEMI ;  PA0 SAC		626 3049 33				
			 MANU ;  PF6 ;  N° 0## SAC		626 3049 33				
			 incl. 		415 0485 10				
						529 0317 10			
 ; A/C				529 0353 10					



			SCHAEFFLER
--	--	--	-------------------

































































NISSAN

NV400						
dCi 145 M9T 678; M9T 680; M9T 706; (107kW)	11.11-06.16		 ; →01.14; A/C		532 0534 10	
					534 0281 10	
			 # F-236675.XX F-561464.XX		535 0080 10	
			 # F-552305.XX		535 0153 10	
			 ; A/C		FB 7PK1973	
					538 0397 10	
			16x  12 mm		420 0086 10	
			16x 		422 0078 10	
			1x 		558 0060 10	
			1x 		559 0172 10	
		1x 		559 0172 30		
		FAG	 right		821 0865 10	
			 left		821 0868 10	
					713 6450 40	
			 90 mm		713 6450 50	
			 80 mm		713 6450 50	
			 ↔		818 0482 10	
			 ↔		818 0475 10	
			 right		825 0333 10	
			 left		825 0332 10	
 ↔			840 0394 10			
 right		840 1143 10				
 left		840 1142 10				
dCi 145 RVD M9T 694; M9T 696; M9T 698; M9T 710; (107kW)	11.11-06.16		 M9T 694 M9T 698;  ZF4		626 3050 00	
			 M9T 694 M9T 698 incl. 		415 0490 10	
					529 0317 10	
			 ; A/C		529 0353 10	
			 ; →01.14; A/C		532 0534 10	
					534 0281 10	
			 # F-236675.XX F-561464.XX		535 0080 10	
			 # F-552305.XX		535 0153 10	
			 ; A/C		FB 7PK1973	
					420 0086 10	
			16x  12 mm		422 0078 10	
			16x 		558 0060 10	
		1x 		559 0172 10		
		1x 		559 0172 30		
		FAG	 right		821 0865 10	
			 left		821 0868 10	
					713 6450 40	
			 90 mm		713 6450 30	
			 ; 		713 6451 60	
			 90 mm		713 6451 60	
 ↔			818 0482 10			
 ↔; 			818 0475 10			
 ↔; 			818 0492 10			
 right			825 0333 10			
 left		825 0332 10				
 ↔		840 0394 10				
 right		840 1143 10				
 left		840 1142 10				
2.3 dCi 150 dCi 150 M9T 880; (110kW)	02.14-09.16		SAC		626 3049 09	
			 PF6 SAC		626 3049 33	
			 ; für Fahrzeuge mit Extra Heizung; 		529 0352 10	
			 ;  A/C		529 0353 10	
			 # F-236675.XX F-561464.XX		535 0080 10	
			 # F-552305.XX		535 0153 10	
			16x  12 mm		420 0086 10	
			16x 		422 0078 10	
			FAG	 right		821 0865 10
				 left		821 0868 10



			SCHAEFFLER
--	--	--	-------------------















































































































NISSAN

NV400						
2.3 dCi 150 dCi 150 M9T 880; (110kW)	02.14-09.16	FAG	 Set 713 6450 40			
			 90 mm			
			 80 mm			
			 ↔			
			 ↔			
			 right			
			 left			
			 ↔			
			 right			
			 left			
			 90 mm			
			 80 mm			
			 ↔			
			 ↔			
dCi 150 RWD M9T 880; (110kW)	02.14-09.16	LUK	 incl.  415 0490 10			
			 16x			
			 12 mm			
			 16x			
			 right			
			 left			
			 90 mm			
			 90 mm			
			 ↔			
			 ↔			
			 ↔			
			 right			
			 left			
			 ↔			
			 right			
			 left			
			 90 mm			
			 90 mm			
			 ↔			
			 ↔			
			 ↔			
			 right			
			 left			
			 90 mm			
 90 mm						
 ↔						
 ↔						
 ↔						
 right						
 left						
dCi 150 M9T 880; (110kW)	08.14-06.16	LUK	 SAC			
			 G6;  PF6			
			 SAC			
			 16x			
			 12 mm			
			 16x			
			 right			
			 left			
			 90 mm			
			 80 mm			
			 ↔			
			 ↔			
			 ↔			
			 right			
			 left			
			 ↔			
			 right			
			 left			
			dCi 165 RWD M9T; (120kW)	06.14-	LUK	 626 3050 00
						# F-236675.XX F-561464.XX
						# F-552305.XX
						16x
						12 mm
						16x
right						
left						
90 mm						
90 mm						
↔						
↔						



			SCHAEFFLER
--	--	--	-------------------











































































































NISSAN

NISSAN NV400			
dCi 165 RWD M9T; (120kW)	06.14-	FAG	    713 6450 30
			    713 6451 60
			 90 mm  818 0482 10
			  818 0475 10
			  818 0492 10
			 right  825 0333 10
			 left  825 0332 10
			  840 0394 10
			 right  840 1143 10
			 left  840 1142 10
			  626 3049 33
			  # F-236675.XX F-561464.XX  535 0080 10
			  # F-552305.XX  535 0153 10
			 16x  12 mm  538 0397 10
 16x  422 0078 10			
2.3 dCi 165 dCi 165 M9T; (120kW)	06.14-09.16	FAG	 right  821 0865 10
			 left  821 0868 10
			 90 mm  713 6450 40
			 80 mm  713 6450 50
			  818 0482 10
			  818 0475 10
			 right  825 0333 10
			 left  825 0332 10
			  840 0394 10
			 right  840 1143 10
			 left  840 1142 10
			  626 3049 33
			  # F-236675.XX F-561464.XX  535 0080 10
			  # F-552305.XX  535 0153 10
 16x  12 mm  538 0397 10			
 16x  422 0078 10			
dCi 160 M9T; (120kW)	06.14-09.16	FAG	 right  821 0865 10
			 left  821 0868 10
			 90 mm  713 6450 40
			 80 mm  713 6450 50
			  818 0482 10
			  818 0475 10
			 right  825 0333 10
			 left  825 0332 10
			  840 0394 10
			 right  840 1143 10
			 left  840 1142 10
			  626 3050 00
			  415 0490 10
			  # F-236675.XX F-561464.XX  535 0080 10
  # F-552305.XX  535 0153 10			
 16x  12 mm  422 0078 10			
dCi 165 RWD M9T; (120kW)	06.14-09.16	FAG	 right  821 0865 10
			 left  821 0868 10
			90 mm 713 6450 40
			713 6450 30
			90 mm 713 6451 60
			818 0482 10
			818 0475 10
			818 0492 10
			right 825 0333 10



			SCHAEFFLER
--	--	--	-------------------

NISSAN

















































































NISSAN				
NV400				
dCi 165 RWD M9T; (120kW)	06.14-09.16	FAG	 left  ↔  right  left	 825 0332 10  840 0394 10  840 1143 10  840 1142 10
dCi 170 M9T; (125kW)	07.15-		 M9T # F-236675.XX F-561464.XX  M9T # F-552305.XX 16x  12 mm 16x	 535 0080 10  535 0153 10  420 0086 10
		FAG	 right  left  90 mm  80 mm  ↔  ↔  right  left  ↔  ↔  right  left  ↔  right  left	 422 0078 10  821 0865 10  821 0868 10  Set 713 6450 40  Set 713 6450 50  818 0482 10  818 0475 10  825 0333 10  825 0332 10  840 0394 10  840 1143 10  840 1142 10  626 3049 09
dCi 170 M9T; (125kW)	06.16-	LUK	 M9T 706 SAC SAC	 626 3049 09  626 3049 33
			# F-236675.XX F-561464.XX # F-552305.XX 16x  12 mm 16x	 535 0080 10  535 0153 10  420 0086 10
		FAG	 right  left  90 mm  80 mm  ↔  ↔  ↔  right  left	 422 0078 10  821 0865 10  821 0868 10  Set 713 6450 40  Set 713 6450 50  818 0482 10  818 0475 10  840 0394 10  840 1143 10  840 1142 10
dCi 170 M9T; (125kW)	09.16-		# F-236675.XX F-561464.XX # F-552305.XX 16x  12 mm 16x	 535 0080 10  535 0153 10  420 0086 10
		FAG	 right  left  90 mm  80 mm  ↔  ↔  ↔  right  left	 422 0078 10  821 0865 10  821 0868 10  Set 713 6450 40  Set 713 6450 50  818 0482 10  818 0475 10  840 0394 10  840 1143 10  840 1142 10
PRIMASTAR				
1.9 dCi 80 M9T; (60kW)	07.02-08.06	LUK	→01.03 →01.03;  PK5.0## →01.03;  PK5.3## 02.03→ 02.03→;  PK5.0## 02.03→;  PK5.3##	 624 3087 09  624 3087 33  624 3087 34  624 3312 09  624 3312 33  624 3312 34
				 530 0196 10  533 0087 20



			SCHAEFFLER
--	--	--	-------------------

NISSAN

PRIMASTAR



























































































































1.9 dCi 80 F9Q 760; (60kW)	07.02-08.06		1111; A/C		529 0124 10
			1111; A/C		529 0427 10
			FAG 1111; ABS; →12.02		713 6441 20
			 86 mm		713 6441 30
			FAG 1111; ABS; →12.02		713 6442 90
			 86 mm		713 6441 40
			1111; 01.03→		814 0135 10
			 88 mm		818 0207 10
			 68 mm		825 0260 10
			 ↔		840 0274 10
			 right		840 0880 10
			 left		840 0879 10
			 →01.03		624 3087 09
			 →01.03; PK6.0##		624 3087 33
			 →01.03; PK6.3##		624 3087 34
 02.03→		624 3312 09			
 02.03→; PK6.0##		624 3312 33			
 02.03→; PK6.3##		624 3312 34			
			530 0196 10		
			533 0087 20		
1111; A/C		529 0124 10			
1111; A/C; -e		529 0427 10			
1111		532 0364 20			
1111		534 0142 30			
1111# F-560843.XX F-556602.XX F-229643.XX		535 0030 10			
1111# F-234637.XX		535 0048 10			
1111; A/C; -e		FB 6PK1835			
			538 0392 10		
FAG 1111; right		821 0490 10			
FAG 1111; left		821 0489 10			
FAG 1111; ABS; →12.02		713 6441 20			
 86 mm		713 6441 30			
FAG 1111; ABS; →12.02		713 6442 90			
 86 mm		713 6441 40			
1111; 01.03→		814 0135 10			
 88 mm		818 0207 10			
 68 mm		825 0260 10			
 ↔		840 0274 10			
 right		840 0880 10			
 left		840 0879 10			
 →01.03		624 3092 09			
 PK6.3##		624 3092 33			
 PK6.0##		624 3092 34			
			529 0124 10		
1111; A/C		529 0427 10			
16x		420 0099 10			
 12 mm					
16x		422 0009 10			
FAG 1111; ABS; →12.02		713 6441 20			
 86 mm		713 6441 30			
FAG 1111; ABS; →12.02		713 6442 90			
 86 mm		713 6441 40			
1111; 01.03→		814 0135 10			
 88 mm		818 0207 10			
68 mm		840 0274 10			
↔		840 0880 10			
right		840 0879 10			
left					



			SCHAEFFLER
--	---	--	-------------------

NISSAN

PRIMASTAR













2.5 dCi 140 110 (99kW)	07.02-08.06		→06.04;  PK6.0## incl.  ; incl.  ; SAC		600 0078 00	
			→06.04 SAC		623 3159 09	
			→06.04;  PK6.3## SAC		623 3159 33	
			→06.04;  PK6.0## SAC		623 3159 34	
			07.04→		624 3945 09	
			07.04→;  PK6.3##		624 3945 33	
			07.04→;  PK6.0##		624 3945 34	
			→06.04 incl. 		415 0146 10	
					530 0198 10	
					531 0548 10	
					532 0313 20	
			 ;  ;  ; # OE 6PK1835		529 0436 10	
			 ;  ; # OE 6PK1835			
			 ; 		532 0364 20	
			 ;  ; 		534 0181 10	
			 ;  ; 		534 0317 10	
			 # F-560843.XX F-556602.XX F-229643.XX		535 0030 10	
			 # F-238512.XX		535 0081 10	
			 ;  ; 		FB 6PK1148	
			 ;  ; →09.03		FB 6PK1153	
			 ; 		FB 6PK1795	
			 ;  ; 			
			 ; 		FB 6PK1835	
			 ;  ; 			
			 ; 10.03→;  ;  ; # OE 93186955 4416361		FB 7PK1103	
			 ; 10.03→;  ;  ; # OE 9121108, 4405275		FB 7PK1145	
			 ; 10.03→; 		FB 7PK1795	
					538 0374 10	
		FAG	 ;  ; →12.02	 Set	713 6441 20	
			 86 mm			
			 ;  ; →12.02	 Set	713 6441 30	
			 86 mm			
			 ; 01.03→	 Set	713 6442 90	
			 88 mm			
			 68 mm	 Set	713 6441 40	
					814 0135 10	
			 ↔		818 0207 10	
					825 0260 10	
				840 0274 10		
		 right		840 0880 10		
		 left		840 0879 10		
		LUK			624 3476 09	
			 PF6.0##		624 3476 34	
					530 0198 10	
					531 0548 10	
					532 0313 20	
			 ;  ; 		529 0428 10	
			 ;  ;  ; # OE 7PK1835		529 0437 10	
					532 0364 20	
			 ; 		534 0181 10	
			 ;  ; 		534 0317 10	
			# F-560843.XX F-556602.XX F-229643.XX		535 0030 10	
			# F-238512.XX		535 0081 10	
			; ; ; # OE 93186955 4416361		FB 7PK1103	
			; ; ; # OE 9121108, 4405275		FB 7PK1145	
			;		FB 7PK1795	
			; ;		FB 7PK1835	
					538 0374 10	
			1x;		428 0185 10	
			1x;		428 0186 10	







































































			SCHAEFFLER
--	--	--	-------------------































NISSAN

PRIMASTAR

2.5 dCi 150 G9U 630; (107kW)	04.06-	FAG	 88 mm		713 6442 90
			 68 mm		713 6441 40
			 ↔		818 0207 10
			 right		840 0274 10
			 left		840 0880 10
			 left		840 0879 10

PRIMASTAR (X83)

dCi 80 F9Q 762; (60kW)	03.01-	LUK	→01.03		624 3087 09	
			→01.03;  PK5.0##		624 3087 33	
			→01.03;  PK5.3##		624 3087 34	
			02.03→		624 3312 09	
			02.03→;  PK5.0##		624 3312 33	
			02.03→;  PK5.3##		624 3312 34	
						530 0196 10
						530 0196 30
						533 0087 20
				 ;  ; →02.02; A/C		529 0118 10
		 ; →08.06; A/C			529 0124 10	
		 ; →08.06; A/C			529 0427 10	
		 ; →02.02			532 0243 10	
		 # F-560843.XX F-556602.XX F-229643.XX			535 0030 10	
		 # F-234637.XX			535 0048 10	
		OPTION			544 0089 10	
		A/C		544 0101 10		
		A/C		544 0101 20		
				538 0392 10		
		FAG	 right; →09.06		821 0490 10	
			 right; 10.06→		821 0822 10	
			 left; →09.06		821 0489 10	
			 left; 10.06→		821 0821 10	
			 ; ABS ; →12.02		713 6441 20	
			 86 mm		713 6441 30	
			 ; ABS ; →12.02		713 6441 30	
			 86 mm		713 6441 30	
			 ; 01.03→		713 6442 90	
			 88 mm		713 6441 40	
			 68 mm		713 6441 40	
			 ↔		771 0507 30	
		 ↔		815 0068 30		
 ↔		818 0207 10				
 ; →09.06		825 0260 10				
 ; 10.06→		825 0261 10				
 ↔		840 0274 10				
 right		840 0880 10				
 left		840 0879 10				















































































































1.9 dCi 80 F9Q 762; (60kW)	09.02-	LUK	→01.03		624 3087 09	
			→01.03;  PK5.0##		624 3087 33	
			→01.03;  PK5.3##		624 3087 34	
			02.03→		624 3312 09	
			02.03→;  PK5.0##		624 3312 33	
			02.03→;  PK5.3##		624 3312 34	
						530 0196 10
						530 0196 30
						533 0087 20
				 ; →08.06; A/C		529 0124 10
		 ; →08.06; A/C			529 0427 10	
		 # F-560843.XX F-556602.XX F-229643.XX			535 0030 10	
		 # F-234637.XX			535 0048 10	
		A/C			544 0101 10	
		A/C			544 0101 20	
					538 0392 10	
		FAG	 right; →09.06		821 0490 10	
			 right; 10.06→		821 0822 10	
			 left; →09.06		821 0489 10	



			SCHAEFFLER
--	---	--	-------------------

NISSAN

PRIMASTAR (X83)

























































































































<p>1.9 dCi 80  F9Q 762; (60kW)</p>	<p>09.02-</p>	<p>FAG</p>	<p> left; 10.06→</p> <p> ; ABS ; →12.02</p> <p> 86 mm</p> <p> ; ABS ; →12.02</p> <p> 86 mm</p> <p> ; 01.03→</p> <p> 88 mm</p> <p> 68 mm</p> <p> 771 0507 30</p> <p> REP 815 0068 30</p> <p> ↔ 818 0207 10</p> <p> ; →09.06 825 0260 10</p> <p> ; 10.06→ 825 0261 10</p> <p> 840 0274 10</p> <p> right 840 0880 10</p> <p> left 840 0879 10</p>	<p>821 0821 10</p> <p> 713 6441 20</p> <p> 713 6441 30</p> <p> 713 6442 90</p> <p> 713 6441 40</p>
<p>dCi 100  F9Q 760; (74kW)</p>	<p>03.01-</p>	<p>LUK</p>	<p>→01.03</p> <p>→01.03;  PK6.0##</p> <p>→01.03;  PK6.3##</p> <p>02.03→</p> <p>02.03→;  PK6.0##</p> <p>02.03→;  PK6.3##</p>	<p> 624 3087 09</p> <p> 624 3087 33</p> <p> 624 3087 34</p> <p> 624 3312 09</p> <p> 624 3312 33</p> <p> 624 3312 34</p>
		<p></p>	<p> 530 0196 10</p> <p> 533 0087 20</p> <p> 529 0118 10</p> <p> 529 0124 10</p> <p> 529 0427 10</p> <p> 532 0243 10</p> <p> 532 0364 20</p> <p> 534 0142 30</p> <p> 534 0240 10</p> <p> 535 0030 10</p> <p> 535 0048 10</p> <p> 544 0101 10</p> <p> 544 0101 20</p> <p> FB 5PK1125</p> <p> FB 6PK1835</p> <p> 538 0392 10</p>	<p> 530 0196 10</p> <p> 533 0087 20</p> <p> 529 0118 10</p> <p> 529 0124 10</p> <p> 529 0427 10</p> <p> 532 0243 10</p> <p> 532 0364 20</p> <p> 534 0142 30</p> <p> 534 0240 10</p> <p> 535 0030 10</p> <p> 535 0048 10</p> <p> 544 0101 10</p> <p> 544 0101 20</p> <p> FB 5PK1125</p> <p> FB 6PK1835</p> <p> 538 0392 10</p>
		<p>FAG</p>	<p> right; →09.06</p> <p> right; 10.06→</p> <p> left; →09.06</p> <p> left; 10.06→</p> <p> ; ABS ; →12.02</p> <p> 86 mm</p> <p> ; ABS ; →12.02</p> <p> 86 mm</p> <p> ; 01.03→</p> <p> 88 mm</p> <p> 68 mm</p> <p> 771 0507 30</p> <p> REP 815 0068 30</p> <p> ↔ 818 0207 10</p> <p> ; →09.06 825 0260 10</p> <p> ; 10.06→ 825 0261 10</p> <p> 840 0274 10</p> <p> right 840 0880 10</p> <p> left 840 0879 10</p>	<p> 821 0490 10</p> <p> 821 0822 10</p> <p> 821 0489 10</p> <p> 821 0821 10</p> <p> 713 6441 20</p> <p> 713 6441 30</p> <p> 713 6442 90</p> <p> 713 6441 40</p> <p> 771 0507 30</p> <p> 815 0068 30</p> <p> 818 0207 10</p> <p> 825 0260 10</p> <p> 825 0261 10</p> <p> 840 0274 10</p> <p> 840 0880 10</p> <p> 840 0879 10</p>
<p>1.9 dCi 100  F9Q 760; (74kW)</p>	<p>09.02-</p>	<p>LUK</p>	<p>→01.03</p> <p>→01.03;  PK6.0##</p> <p>→01.03;  PK6.3##</p> <p>02.03→</p> <p>02.03→;  PK6.0##</p> <p>02.03→;  PK6.3##</p>	<p> 624 3087 09</p> <p> 624 3087 33</p> <p> 624 3087 34</p> <p> 624 3312 09</p> <p> 624 3312 33</p> <p> 624 3312 34</p>



			SCHAEFFLER
--	---	--	-------------------

NISSAN





































































































PRIMASTAR (X83)

<p>1.9 dCi 100 F9Q 760; (74kW)</p>	09.02-				530 0196 10
					530 0196 30
					533 0087 20
			 ; →08.06; A/C		529 0124 10
			 ; →08.06; A/C ; 		529 0427 10
			 ; →08.06		532 0364 20
			 # F-560843.XX F-556602.XX F-229643.XX		535 0030 10
			 # F-234637.XX		535 0048 10
			A/C		544 0101 10
			A/C		544 0101 20
		 ; →08.06; A/C		FB 5PK1125	
		 ; →08.06; A/C ; 		FB 6PK1835	
				538 0392 10	
		FAG	 right; →09.06		821 0490 10
			 right; 10.06→		821 0822 10
			 left; →09.06		821 0489 10
			 left; 10.06→		821 0821 10
			 ; ABS ; →12.02		713 6441 20
			 86 mm		
			 ; ABS ; →12.02		713 6441 30
 86 mm					
 ; 01.03→			713 6442 90		
 88 mm					
	 68 mm		713 6441 40		
			771 0507 30		
			815 0068 30		
	 ↔		818 0207 10		
	 ; →09.06		825 0260 10		
	 ; 10.06→		825 0261 10		
			840 0274 10		
	 right		840 0880 10		
	 left		840 0879 10		
			624 3476 09		
<p>2.0 dCi 90 dCi 90 M9R 692; M9R 782; M9R 786; (66kW)</p>	09.06-		 PF6.0##		624 3476 34
					
		 ; →01.14; A/C			532 0534 10
		 # F-236675.XX F-561464.XX			535 0080 10
		 ; PTO ; A/C			FB 7PK1741
		 ; A/C ; PTO			FB 7PK1973
		 ; A/C			
		 ; PTO ; A/C			FB 7PK2000
					538 0397 10
		16x			420 0086 10
		 12 mm			
		16x		422 0078 10	
		1x		558 0059 10	
		1x		559 0171 10	
		1x		559 0171 30	
		FAG	 right		821 0822 10
			 left		821 0821 10
			 88 mm		713 6442 90
			 68 mm		713 6441 40
					814 0135 10
 ↔			818 0207 10		
 ; 10.06→			825 0261 10		
			840 0274 10		
 right			840 0880 10		
 left			840 0879 10		
		624 3476 09			
<p>2.0 dCi 115 dCi 120 M9R 630; M9R 692; M9R 780; M9R 786; (84kW)</p>	09.06-		 PF6.0##		624 3476 34
					
		 ; →01.14; A/C			532 0534 10
					534 0281 10
		 # F-236675.XX F-561464.XX			535 0080 10
		 ; A/C			FB 7PK1741
					538 0397 10



			SCHAEFFLER
--	--	--	-------------------

NISSAN

















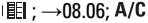

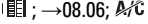

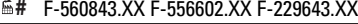

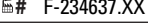





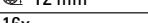

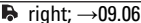

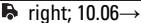

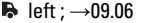

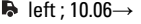



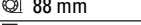



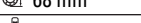





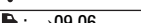

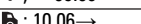



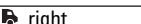



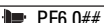









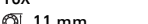

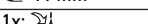



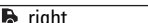









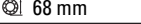







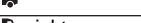

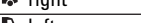

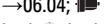





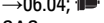

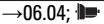



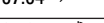

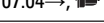
PRIMASTAR (X83)							
2.0 dCi 115 dCi 120 M9R 630; M9R 692; M9R 780; M9R 786; (84kW)	09.06-		16x		420 0086 10		
			 12 mm				
			16x		422 0078 10		
			1x		558 0059 10		
			1x		559 0171 10		
		FAG			right		821 0822 10
					left		821 0821 10
					88 mm		713 6442 90
					68 mm		713 6441 40
							814 0135 10
					↔		818 0207 10
					↔; 10.06→		825 0261 10
							840 0274 10
					right		840 0880 10
					left		840 0879 10
2.0 F4R 820; (86kW)	04.06-				624 3092 09		
			PK6.3##		624 3092 33		
			PK6.0##		624 3092 34		
				↔; A/C		529 0124 10	
				↔; A/C		529 0427 10	
				16x		420 0099 10	
				 12 mm			
				16x		422 0009 10	
						713 6442 90	
				88 mm		713 6441 40	
				68 mm			
				↔		818 0207 10	
						840 0274 10	
				right		840 0880 10	
				left		840 0879 10	
2.0 F4R 720; F4R 722; (88kW)	03.01-				624 3092 09		
			PK6.3##		624 3092 33		
			PK6.0##		624 3092 34		
				↔; +  ; →03.02; A/C		532 0654 10	
				↔; →08.06; A/C		529 0118 10	
				↔; →08.06; A/C		529 0124 10	
				↔; →03.02		529 0427 10	
				↔; →03.02		532 0243 10	
				## F-560843.XX F-556602.XX F-229643.XX		535 0030 10	
				## F-234637.XX		535 0048 10	
						538 0392 10	
				16x		420 0099 10	
				 12 mm			
				16x		422 0009 10	
						821 0490 10	
		right; →09.06		821 0822 10			
		right; 10.06→		821 0489 10			
		left; →09.06		821 0821 10			
		left; 10.06→		821 0821 10			
		↔; ABS; →12.02		713 6441 20			
				713 6441 30			
		↔; ABS; →12.02		713 6441 30			
				713 6442 90			
		↔; 01.03→		713 6442 90			
				713 6441 40			
		68 mm		713 6441 40			
				771 0507 30			
				815 0068 30			
		↔		818 0207 10			
		↔; →09.06		825 0260 10			
		↔; 10.06→		825 0261 10			
				840 0274 10			
		right		840 0880 10			
		left		840 0879 10			



			SCHAEFFLER
--	---	--	-------------------

NISSAN

PRIMASTAR (X83)





























































































































2.0 F4R 720; (88kW)	02.03-				624 3092 09
					624 3092 33
					532 0654 10
					529 0124 10
					529 0427 10
					535 0030 10
					535 0048 10
					538 0392 10
					420 0099 10
		FAG	 right; →09.06		422 0009 10
			 right; 10.06→		821 0490 10
			 left; →09.06		821 0822 10
			 left; 10.06→		821 0489 10
					821 0821 10
			 88 mm		713 6442 90
			 68 mm		713 6441 40
					771 0507 30
					814 0135 10
					818 0207 10
			 →09.06		825 0260 10
			 ; 10.06→		825 0261 10
					840 0274 10
			 right		840 0880 10
			 left		840 0879 10
2.5 dCi 115 dCi 115 G9U 630; (84kW)	09.08-				624 3476 09
					624 3476 34
					530 0198 10
					531 0548 10
					532 0313 20
					538 0374 10
					420 0063 10
					428 0185 10
					428 0186 10
		FAG	 right		821 0822 10
			 left		821 0821 10
			 88 mm		713 6442 90
			 68 mm		713 6441 40
					814 0135 10
					818 0207 10
					825 0261 10
					840 0274 10
			 right		840 0880 10
			 left		840 0879 10
2.5 dCi 140 dCi 140 G9U 730; (99kW)	07.03-		→06.04; 		600 0078 00
			incl.  ; SAC		623 3159 09
			→06.04		623 3159 33
			SAC		623 3159 34
			→06.04; 		624 3945 09
			SAC		624 3945 33
			→06.04; 		624 3945 34
			SAC		624 3945 09
			07.04→		624 3945 33
			07.04→; 		624 3945 34
			07.04→; 		415 0146 10
			→06.04		530 0198 10
			incl. 		531 0548 10
			532 0313 20		
				529 0436 10	
					



			SCHAEFFLER
--	---	--	-------------------

NISSAN

PRIMASTAR (X83)

2.5 dCi 140 dCi 140  G9U 730; (99kW)	07.03-		 ; →08.06; A/C		532 0364 20
			 ; →08.06; A/C		534 0181 10
			 ; →08.06; A/C ; -e		
			 ; →08.06; A/C ; -e		534 0317 10
			 # F-560843.XX F-556602.XX F-229643.XX		535 0030 10
			 ; →08.06; A/C ; -e		FB 6PK1148
			 ; A/C		FB 6PK1153
			 ; →08.06; A/C		FB 6PK1795
			 ; →08.06; A/C ; -e		
			 ; →08.06; A/C		FB 6PK1835
		 ; →08.06; A/C ; -e			
				538 0374 10	
		16x		420 0063 10	
		 11 mm			
		1x; 		428 0185 10	
		1x; 		428 0186 10	
		FAG	 right; →09.06		821 0490 10
			 right; 10.06→		821 0822 10
			 left; →09.06		821 0489 10
			 left; 10.06→		821 0821 10
			Set 713 6442 90		
 88 mm					
			Set 713 6441 40		
 68 mm					
			REP 815 0068 30		
			818 0207 10		
 ; →09.06			825 0260 10		
 ; 10.06→			825 0261 10		
			840 0274 10		
 right			840 0880 10		
 left			840 0879 10		
2.5 dCi 150  G9U 632; (107kW)	09.06-	LUK	 PF6.0##		624 3476 09
			 PF6.0##		624 3476 34
					530 0198 10
					531 0548 10
					532 0313 20
			 ; A/C ; -e		529 0428 10
			 ; A/C ; -e ; # OE 7PK1835		529 0437 10
					532 0364 20
			 ; →01.14; A/C		532 0534 10
			 ; A/C		534 0181 10
			 ; A/C ; -e		
			 ; A/C ; -e		534 0317 10
			 # F-560843.XX F-556602.XX F-229643.XX		535 0030 10
			 # F-238512.XX		535 0081 10
			 ; 09.10→		544 0110 10
			 ; A/C		FB 7PK1795
			 ; A/C ; -e		FB 7PK1835
					538 0374 10
			16x		420 0063 10
			 11 mm		
1x; 		428 0185 10			
1x; 		428 0186 10			
FAG	 right		821 0822 10		
	 left		821 0821 10		
			Set 713 6442 90		
	 88 mm				
			Set 713 6441 40		
	 68 mm				
			814 0135 10		
			818 0207 10		
	 ; 10.06→		825 0261 10		
			840 0274 10		
 right		840 0880 10			
 left		840 0879 10			
dCi 150  G9U 632; (107kW)	09.06-	LUK	 PF6.0##		624 3476 09
			 PF6.0##		624 3476 34
			530 0198 10		
			531 0548 10		



			SCHAEFFLER
--	---	--	-------------------

























































NISSAN

PRIMASTAR (X83)

dCi 150
 G9U 632; (107kW)

09.06-



	; A/C ; -e		532 0313 20
	; A/C ; e ; # OE 7PK1835		529 0428 10
			529 0437 10
	→01.14; A/C		532 0364 20
	; A/C		532 0534 10
	; A/C ; e		534 0181 10
	; A/C ; -e		534 0317 10
	# F-560843.XX F-556602.XX F-229643.XX		535 0030 10
	# F-238512.XX		535 0081 10
	; OPTION		544 0110 10
	; 09.10→		544 0110 10
	; A/C		FB 7PK1795
	; A/C ; e		FB 7PK1835
			538 0374 10
	16x		420 0063 10
	11 mm		
	1x; 		428 0185 10
	1x; 		428 0186 10
	right		821 0822 10
	left		821 0821 10
	88 mm		Set 713 6442 90
	68 mm		Set 713 6441 40
			814 0135 10
	↔		818 0207 10
	; 10.06→		825 0261 10
	right		840 0274 10
	left		840 0880 10
			840 0879 10





























































OPEL

COMBO C

1.3 CDTI 16V
 Z 13 DT; (51kW)

08.05-















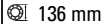

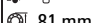





























































































































	→2494873; MANU		600 0164 00
	incl.  ; incl. 		600 0165 00
	2494874→; MANU		622 3095 33
	incl.  ; incl. 		622 3100 33
	→2494873; MANU		622 3146 33
	SEMI ; Easytronic		415 0232 10
	SAC		415 0442 10
	2494874→; MANU		411 0124 10
	→2494873; MANU		529 0346 10
	SEMI ; Easytronic		534 0053 10
	incl. 		535 0063 10
	2494874→; MANU		535 0151 10
	; A/C		544 0029 10
			FB 6PK1180
			538 0442 10
			400 0577 10
	1x		428 0030 30
	1x		SKIT 559 0019 10
	1x		SKIT 559 0027 30
	1x		SKIT 559 0028 30
	1x		SKIT 559 0053 10
	1x		SKIT 559 0135 10
	1x		SKIT 559 0146 10
	right; - bad road pack.		821 0292 10
	left; - bad road pack.		821 0291 10
			Set 713 6440 80
	67 mm		
	ABS		Set 713 6445 50
	136 mm		



			SCHAEFFLER
--	--	--	-------------------

OPEL

COMBO C



























































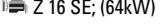







































































1.3 CDTI 16V Z 13 DT; (51kW)	08.05-	FAG	 ; ABS		713 6445 60		
			 136 mm		771 0285 30		
			 81 mm		772 0157 30		
			 ;		815 0028 30		
					818 0174 10		
					825 0128 10		
			 ↔;  ...43000001 →		840 0384 10		
			 ↔;  ...44000001 →				
			 ↔;  ...46000001 →				
			 ↔;  ...43000001 →		840 0415 10		
			 ↔;  ...44000001 →				
			 ↔;  ...46000001 →				
			 ;  →33999999 34999999 36999999		840 0156 10		
					840 0785 10		
				 →2494873;  MANU incl.  ; incl. 		600 0164 00	
			 2494874 →  3740424;  MANU incl.  ; incl. 		600 0165 00		
			 →2494873;  MANU		622 3095 33		
			 SEMI ;  Easytronic SAC		622 3100 33		
			 2494874 →  3740424;  MANU		622 3146 33		
			 3740425 →;  MANU		622 3236 33		
 →2494873;  MANU		415 0232 10					
 SEMI ;  Easytronic incl. 							
 2494874 →  3740424;  MANU		415 0442 10					
		411 0124 10					
		 ; A/C 		529 0346 10			
		 # F-237101.XX		535 0063 10			
		 # F-557928.XX		535 0151 10			
		 ; A/C		544 0029 10			
				FB 6PK1180			
				538 0442 10			
				400 0577 10			
			 1x		428 0030 30		
			 1x		559 0019 10		
			 1x		559 0027 30		
			 1x		559 0028 30		
			 1x		559 0053 10		
			 1x		559 0135 10		
			 1x		559 0146 10		
		FAG	 right; - bad road pack.		821 0292 10		
			 left; - bad road pack.		821 0291 10		
					713 6440 80		
			 67 mm				
			 ; ABS		713 6445 50		
			 136 mm		713 6445 60		
			 ; ABS				
			 136 mm		815 0028 30		
			 ;		818 0174 10		
					825 0128 10		
			 ↔;  ...43000001 →		840 0384 10		
			 ↔;  ...44000001 →				
			 ↔;  ...46000001 →				
			 ;  →33999999 34999999 36999999		840 0156 10		
					840 0785 10		
1.4 16V Z 14 XEP; (66kW)	08.05-		 MANU		620 3090 34		
			 SEMI ;  Easytronic SAC		621 3026 33		
					 ; A/C		529 0296 10
					 ; A/C		529 0324 10
					 ; A/C ; 		529 0010 30
							
					538 0082 10		



			SCHAEFFLER
--	---	--	-------------------

OPEL

COMBO C



























































































































































































<p>1.4 16V  Z 14 XEP; (66kW)</p>	<p>08.05-</p>		<p>16x  13 mm 16x 1x;  →19TR2328 1x;  →19TR2328 1x;  →19TR2328 FAG  right; - bad road pack.  left; - bad road pack.  67 mm  ; ABS  136 mm  ; ABS  136 mm  81 mm  81 mm  ;  ;  ;  ↔;  ...43000001 →  ↔;  ...44000001 →  ↔;  ...46000001 →  ;  →33999999 34999999 36999999  ;</p>	<p> 538 0320 10  400 0577 10  420 0072 10  422 0006 10  559 0024 30  559 0025 30  559 0057 10  821 0292 10  821 0291 10  713 6440 80  713 6445 50  713 6445 60  771 0285 30  772 0157 30  815 0028 30  818 0174 10  825 0128 10  840 0415 10  840 0156 10  840 0785 10  621 3027 33</p>
<p>1.6  Z 16 SE; (64kW)</p>	<p>10.01-</p>	 	<p> ; A/C  ; A/C  ; A/C 1x FAG  right; - bad road pack.  left; - bad road pack.  67 mm  ; ABS  136 mm  ; ABS  136 mm  81 mm  81 mm  ;  ;  ;  ↔;  ...43000001 →  ↔;  ...44000001 →  ↔;  ...46000001 →  ;  →33999999 34999999 36999999  ;</p>	<p> 530 0004 10  530 0004 31  531 0101 30  529 0008 10  534 0115 20  FB 5PK940  538 0302 10  428 0041 30  821 0292 10  821 0291 10  713 6440 80  713 6445 50  713 6445 60  771 0285 30  772 0157 30  815 0028 30  818 0174 10  825 0128 10  840 0415 10  840 0156 10  840 0785 10  621 3027 33  621 3045 33  530 0441 10  530 0441 30  531 0518 30  532 0033 10  532 0478 10  529 0008 10  534 0115 20  FB 5PK940  538 0296 10  420 0118 10  428 0093 10</p>
<p>1.6 CNG 16V  Z 16 YNG; (69kW)</p>	<p>06.06-</p>	 	<p> →20KC2904  20KC2905 →  ; A/C  ; A/C 16x  32 mm  ; 1x</p>	<p> 621 3027 33  621 3045 33  530 0441 10  530 0441 30  531 0518 30  532 0033 10  532 0478 10  529 0008 10  534 0115 20  FB 5PK940  538 0296 10  420 0118 10  428 0093 10</p>



			SCHAEFFLER
--	--	--	-------------------

OPEL

COMBO C































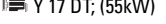





























































































1.6 CNG 16V Z 16 YNG; (69kW)	06.06-	FAG	  Set 713 6440 80
			 67 mm
			 ; ABS
			 136 mm  Set 713 6445 50
			 ; ABS
			 136 mm  Set 713 6445 60
			 
			 81 mm  771 0285 30
			 
			 ;  SET 772 0157 30
			 ;  REP 815 0028 30
			  818 0174 10
			  825 0128 10
			  840 0415 10
			  840 0156 10
  840 0785 10			
   →20KC2904  621 3027 33			
   →20KC2905  621 3045 33			
	  KIT 530 0441 10		
	  530 0441 30		
	  531 0518 30		
	 532 0033 10		
	 532 0478 10		
 ; A/C	  KIT 529 0008 10		
	  534 0115 20		
 ; A/C	  FB 5PK940		
	 538 0296 10		
16x	 420 0118 10		
 32 mm			
 ; 1x	 428 0093 10		
FAG	  Set 713 6440 80		
 67 mm			
 ; ABS	  Set 713 6445 50		
 136 mm			
 ; ABS	  Set 713 6445 60		
 136 mm			
 ;  REP 815 0028 30			
  818 0174 10			
  825 0128 10			
  840 0415 10			
  840 0156 10			
  840 0785 10			
   →20KC2904  621 3029 34			
	  KIT 530 0492 10		
	  KIT 530 0494 10		
	  531 0819 10		
	 532 0504 10		
 ; A/C	  KIT 529 0345 10		
	  534 0082 30		
 ; A/C	  FB 6PK1250		
	 538 0096 10		
16x	 421 0059 10		
 31 mm			
	 428 0098 10		
	 428 0097 10		
  821 0292 10			
  821 0291 10			
  Set 713 6440 80			
 67 mm			
 ; ABS	  Set 713 6445 50		
 136 mm			
 ; ABS	  Set 713 6445 70		
 139 mm			
  771 0285 30			
 81 mm			
  SET 772 0157 30			
			
1.7 DI 16V Y 17 DTL; (48kW)	10.01-	LUK	  KIT 530 0492 10
			  KIT 530 0494 10
		OPTION	  531 0819 10
			 532 0504 10
		 ; A/C	  KIT 529 0345 10
			  534 0082 30
		 ; A/C	  FB 6PK1250
			 538 0096 10
		16x	 421 0059 10
		 31 mm	
			 428 0098 10
			 428 0097 10
		  821 0292 10	
		  821 0291 10	
		  Set 713 6440 80	
		 67 mm	
		 ; ABS	  Set 713 6445 50
		 136 mm	
		 ; ABS	  Set 713 6445 70
		 139 mm	
		  771 0285 30	
		 81 mm	
		  SET 772 0157 30	
			



			SCHAEFFLER
--	---	--	-------------------

OPEL

COMBO C















<p>1.7 DI 16V  Y 17 DTL; (48kW)</p>	10.01-	FAG	 ;	 REP	815 0028 30						
					818 0174 10						
					825 0128 10						
			 ↔;  ...43000001→		840 0415 10						
			 ↔;  ...44000001→								
			 ↔;  ...46000001→								
			 ;  →33999999 34999999 36999999		840 0156 10						
					840 0785 10						
					621 3029 33						
					530 0492 10						
			<p>1.7 DTI 16V  Y 17 DT; (55kW)</p>	10.01-	LUK	OPTION		530 0494 10			
		531 0819 10									
		532 0504 10									
 ; A/C		529 0345 10									
		534 0082 30									
 ; A/C		FB 6PK1250									
		538 0096 10									
16x		421 0059 10									
 31 mm											
		428 0098 10									
		428 0097 10									
FAG		 right; - bad road pack.					821 0292 10				
						 left; - bad road pack.		821 0291 10			
								713 6440 80			
						 67 mm					
						 ; ABS		713 6445 50			
						 136 mm					
						 ; ABS		713 6445 70			
						 139 mm					
						 =		771 0285 30			
						 81 mm					
						 =		772 0157 30			
								815 0028 30			
					818 0174 10						
					825 0128 10						
			 ↔;  ...43000001→		840 0415 10						
			 ↔;  ...44000001→								
			 ↔;  ...46000001→								
			 ;  →33999999 34999999 36999999		840 0156 10						
					840 0785 10						
<p>1.7 CDTI 16V  Z 17 DTH; (74kW)</p>	12.04-	LUK	G5		600 0166 00						
			incl.  ; incl. 		623 3234 33						
			G5		415 0256 10						
					411 0121 10						
			OPTION				530 0492 10				
								530 0494 10			
								531 0819 10			
								532 0504 10			
						 ; A/C		532 0402 30			
								534 0321 10			
						 # F-232353/01/03 F-240113.XX		535 0065 10			
								544 0081 10			
						 ; A/C		FB 6PK1275			
						 ; A/C		FB 6PK1600			
						 1232415→		538 0096 10			
						16x		421 0059 10			
						 31 mm					
								428 0098 10			
								428 0097 10			
						FAG		 right; - bad road pack.		821 0292 10	
									 left; - bad road pack.		821 0291 10
											713 6446 70
									 72 mm		
 ; ABS		713 6445 50									
 136 mm											
 ; ABS		713 6445 70									
139 mm											
		815 0028 30									







































































































			SCHAEFFLER
--	--	--	-------------------

OPEL

COMBO C

1.7 CDTI 16V ≡ Z 17 DTH; (74kW)	12.04-	FAG	 818 0174 10		818 0174 10
			 825 0128 10		825 0128 10
			 ↔; ≡ ...43000001 →		840 0415 10
			 ↔; ≡ ...44000001 →		
			 ↔; ≡ ...46000001 →		
			 ; ≡ →33999999 34999999 36999999		840 0156 10
					840 0785 10

COMBO D (X12)











































































































1.3 CDTI (B05) ≡ A 13 FD; (59kW)	02.12-	LUK	bis Euro 5		622 3238 00
				512 0437 10	
			 ; A/C		529 0380 10
					532 0907 10
					534 0455 10
			 ; A/C		544 0029 10
		FAG	 ; 	 Set	713 6908 00
			 74 mm	 Set	713 6908 10
			 ; 	 Set	713 6909 80
			 82,5 mm	 Set	713 6909 90
					818 0278 10
					840 0404 10
					
					
1.3 CDTI (B05) ≡ A 13 FD; (66kW)	02.12-	LUK	bis Euro 5		622 3238 00
				512 0437 10	
			 ; A/C		529 0380 10
					532 0907 10
					534 0455 10
			 # F-557928.XX		535 0151 10
		 # F-583190		535 0311 10	
		 B 13 DTC		535 0327 10	
		 # F-588627			
				544 0029 10	
		 ; A/C		FB 6PK1525	
				400 0577 10	
				420 0181 10	
		16x		422 0064 10	
		 12 mm			
		16x		559 0019 10	
		1x		559 0027 30	
		1x		559 0028 30	
		1x		559 0053 10	
		1x		559 0135 10	
		1x		559 0146 10	
		FAG	 right		821 0908 10
 left			821 0893 10		
 ; 	 Set		713 6908 00		
 74 mm	 Set		713 6908 10		
 ; 	 Set		713 6909 80		
 82,5 mm	 Set		713 6909 90		
			818 0278 10		
			825 0380 10		
		840 0404 10			
1.3 CDTI (B05) ≡ A 13 FD; (70kW)	03.16-	LUK	bis Euro 5		622 3238 00
				512 0437 10	
			 ; A/C		529 0380 10
					532 0907 10
					534 0455 10
			 # F-557928.XX		535 0151 10
		 # F-583190		535 0311 10	
				544 0029 10	
		 ; A/C		FB 6PK1525	
				400 0577 10	
FAG	 right		821 0908 10		



			SCHAEFFLER
--	--	--	-------------------

PEL

COMBO D (X12)









































































































1.3 CDTI (B05) A 13 FD; (70kW)	03.16-	FAG	 left		821 0893 10			
			 	 Set	713 6908 00			
			 74 mm	 Set	713 6908 10			
			 	 Set	713 6909 80			
			 	 Set	713 6909 90			
			 ↔		818 0278 10			
			 ↔		825 0380 10			
			 ↔		840 0404 10			
			1.4 (B05) A 14 FP; (70kW)	02.12-				530 0228 10
								530 0228 30
 ; A/C		531 0414 30						
		529 0013 10						
A/C		534 0069 10						
 # F-558432.XX		535 0171 10						
 ; A/C		FB 4PK668						
		538 0062 10						
16x		420 0210 10						
 28,38 mm								
FAG	 right				821 0908 10			
	 left				821 0893 10			
	 	 Set			713 6908 00			
	 74 mm	 Set			713 6908 10			
	 	 Set			713 6909 80			
	 	 Set	713 6909 90					
			818 0278 10					
	 ↔		825 0380 10					
	 ↔		840 0404 10					
1.4 (B05) 1.4 CNG (B05) A 14 FC; (88kW)	02.12-	LUK			622 3132 09			
					415 0678 10			
					411 0169 10			
					530 0228 10			
					530 0228 30			
			 ; A/C		531 0414 30			
					529 0013 10			
			 ; A/C		534 0069 10			
					FB 4PK668			
				538 0062 10				
		16x		420 0210 10				
		 28,38 mm						
		FAG	 right		821 0908 10			
			 left		821 0893 10			
			 	 Set	713 6908 00			
 74 mm	 Set		713 6908 10					
 	 Set		713 6909 80					
 	 Set		713 6909 90					
			818 0278 10					
 ↔			825 0380 10					
 ↔			840 0404 10					
1.6 CDTI (B05) A 16 FDH; A 16 FDL; (66-77kW)	02.12-	LUK	EURO 5 ;  SEMI ;  Easytronic		623 3540 00			
			EURO 5 ; G6		624 3742 33			
			SAC					
			EURO 5 ; G6 ; START/STOP		415 0541 10			
			EURO 5 ; G6 ; START/STOP		415 0679 10			
			EURO 5 ;  SEMI ; START/STOP		415 0720 10			
		G6		411 0122 10				
					530 0561 10			
					530 0561 30			
					531 0844 10			
			532 0611 10					



			SCHAEFFLER
--	--	--	-------------------



OPEL















COMBO D (X12)						
1.6 CDTI (B05) A 16 FDH; A 16 FDL; (66-77kW)	02.12-		 ; A/C	 532 0505 10		
				 532 0617 10		
				 534 0610 10		
			Ⓜ# F-238822.XX	 535 0112 10		
			Ⓜ# F-565229.XX F-568861.XX	 535 0181 10		
			 ; A/C	 544 0080 20		
			 ; A/C	 FB 6PK1370		
				 FB 6PK1705		
			16x	 538 0714 10		
			 12 mm	 420 0181 10		
			16x	 422 0075 10		
			FAG	 right	 821 0908 10	
				 left	 821 0893 10	
				 ; 	 713 6908 00	
				 74 mm	 713 6908 10	
	 ; 	 713 6909 80				
	 82,5 mm	 713 6909 90				
	 ; 	 818 0278 10				
	 ↔	 825 0380 10				
	 ↔	 840 0404 10				
1.6 CDTI (B05) A 16 FDL; (88kW)	04.15-			 530 0561 10		
				 530 0561 30		
				 531 0844 10		
				 532 0611 10		
				 532 0505 10		
				 532 0617 10		
				 534 0610 10		
				 535 0112 10		
				 A 16 FD*	 535 0181 10	
				Ⓜ# F-238822.XX		
				 A 16 FD*	 535 0181 10	
				Ⓜ# F-565229.XX F-568861.XX		
				 ; A/C	 544 0080 20	
				 ; A/C	 FB 6PK1370	
				 ; A/C	 FB 6PK1705	
	FAG	 right	 821 0908 10			
		 left	 821 0893 10			
		 ; 	 713 6908 00			
		 74 mm	 713 6908 10			
		 ; 	 713 6909 80			
		 82,5 mm	 713 6909 90			
		 ; 	 818 0278 10			
		 ↔	 825 0380 10			
		 ↔	 840 0404 10			
2.0 CDTI (B05) A 20 FD; (99kW)	02.12-			 530 0562 10		
				 530 0562 30		
				 531 0844 10		
				 532 0611 10		
				 532 0505 10		
				 532 0617 10		
				 534 0610 10		
				 535 0112 10		
				 535 0181 10		
				 544 0080 20		
				 FB 6PK1370		
				 FB 6PK1705		
				 538 0714 10		
				16x	 420 0181 10	
				 12 mm	 422 0075 10	
	16x	 422 0075 10				
	FAG	 right	 821 0908 10			
		 left	 821 0893 10			
		 ; 	 713 6908 00			
		 74 mm				



























































































































			SCHAEFFLER
--	---	--	-------------------

OPEL

COMBO D (X12)

2.0 CDTI (B05) A 20 FD; (99kW)	02.12-	FAG	 ; 	 Set	713 6908 10
			 82,5 mm	 Set	713 6909 80
			 ; 	 Set	713 6909 90
					818 0278 10
			 ↔		825 0380 10
			 ↔		840 0404 10

MOVANO A Box (F9)



















































1.9 DTI (FD) F9Q 772; F9Q 774; (60kW)	10.01-	LUK	G5;  PK5.004 PK5.012 PK5.018 PK5.068 PK5.072	GearBOX	462 0155 10	
			G5;  PK5.022	GearBOX	462 0202 10	
			G5;  PK5.372	GearBOX	462 0203 10	
			 → C039090		624 3087 09	
			→05.05;  → C039090;  PK5;  № 0##		624 3087 33	
			06.05 →;  → C039090;  PK5.3##		624 3087 34	
			 C039091 →		624 3312 09	
			→05.05;  C039091 →;  PK5;  № 0##		624 3312 33	
			06.05 →;  C039091 →;  PK5;  № 3##		624 3312 34	
						
						530 0196 30
						533 0087 20
		 ; +  ;  → C029793; A/C			529 0118 10	
		 ;  C029794 →; A/C			529 0124 10	
		 ; A/C			529 0427 10	
		 ; -				
		 ; A/C;  → C029793			532 0243 10	
		 ; A/C;  C029794 →			532 0364 20	
		 ; A/C			534 0142 30	
					535 0030 10	
			 # F-560843.XX F-556602.XX F-229643.XX		535 0048 10	
			 # F-234637.XX		544 0089 10	
			A/C		544 0101 10	
			A/C		544 0101 20	
			 ; A/C		FB 6PK1795	
					538 0392 10	
			FAG	 right ↓ down; →09.07		821 0558 10
				 right ↓ down; 09.07 →		821 0857 10
				 left ↓ down; →09.07		821 0557 10
		 left ↓ down; 09.07 →			821 0855 10	
		 ; B001462 →;  15"		 Set	713 6307 90	
		 ; B000486 →;  15"				
		 ; B000207 →;  15"				
		 ; B000807 →;  15"				
		 ; B000184 →;  15"				
		 ;  16"				
		 84 mm				
		 ; →B001461;  15"		 Set	713 6308 00	
		 ; →B000485;  15"				
		 ; →B000206;  15"				
		 ; →B000806;  15"				
		 ; →B000183;  15"				
		 84 mm				
		 ;  16"		 Set	713 6307 80	
		 80 mm				
		 ;  15"		 Set	713 6308 10	
		 80 mm				
		 ;  ; ABS			771 0292 30	
		 101,9 mm				
		 right			818 0206 10	
 left		818 0205 10				
 ↓ down; →09.07		825 0166 10				
 ↑ up 		825 0167 10				
 ↑ up 		825 0280 10				
 ↓ down; 09.07 →		825 0300 10				
		840 0198 10				
 right		840 0878 10				
 left		840 0877 10				



			SCHAEFFLER
--	--	--	-------------------

OPEL

MOVANO A Box (F9)

2.5 DTi (FD) G9U 754; (73kW)	10.03-		G6 ; PK6.019 PK6.020 PK6.029 PK6.030 PK6.069 PK6.070 PK6.079 PK6.080	GearBOX	462 0202 10
			→12.05; PK5 ; N° 0## 01.06→; PK5 ; N° 3##		624 3476 09
2.5 CDTi (FD) G9U 632; G9U 650; (74-107kW)	10.03-		A/C ; -e		624 3476 33
			A/C ; e		624 3476 34
			A/C ; -e		530 0198 10
			A/C ; e		531 0548 10
			A/C ; -e		532 0313 20
			A/C ; e		529 0432 10
			A/C ; -e		529 0436 10
			A/C ; e		532 0333 10
			F-238512.XX A/C		532 0364 20
			A/C ; -e ; OPTION		535 0081 10
			A/C ; e ; OPTION		544 0098 10
			A/C ; -e		FB 7PK1103
			A/C ; e		FB 7PK1795
			16x 11 mm		538 0374 10
			1x ; 1x ;		420 0063 10
			right ↓ down; →09.07 right ↓ down; 09.07→ left ↓ down; →09.07 left ↓ down; 09.07→		428 0185 10
			B001462→; 15" B000486→; 15" B000207→; 15" B000807→; 15" B000184→; 15" 16" 84 mm		428 0186 10
			→B001461; 15" →B000485; 15" →B000206; 15" →B000806; 15" →B000183; 15" 84 mm		821 0558 10
			16" 80 mm		821 0857 10
			15" 80 mm		821 0857 10
			right left ↓ down; →09.07 ↑ up ↑ up ↓ down; 09.07→		821 0557 10
			right left		821 0855 10
			right left		821 0855 10
			right left		713 6307 90
			right left		713 6308 00
			right left		713 6307 80
			right left		713 6308 10
			right left		818 0206 10
right left		818 0205 10			
right left		825 0166 10			
right left		825 0167 10			
right left		825 0280 10			
right left		825 0300 10			
right left		840 0198 10			
right left		840 0878 10			
right left		840 0877 10			
2.5 CDTi (FD) G9U 632; G9U 650; (74-107kW)	10.03-		MANU ; PF6 ; N° 0##		624 3476 09
			MANU ; PF6 ; N° 0##		624 3476 34
			A/C ; -e ; OPTION		530 0198 10
			A/C ; e ; OPTION		531 0548 10
			A/C ; -e		532 0313 20
			A/C ; e		529 0437 10
			A/C ; -e		532 0333 10
			A/C ; e		532 0364 20
			A/C ; -e		532 0534 10
			A/C ; e		534 0181 10



			SCHAEFFLER
--	--	--	-------------------





















OPEL

MOVANO A Box (F9)































































2.5 CDTI (FD)
 G9U 632; G9U 650; (74-107kW)

10.03-



 A/C		534 0317 10
 -e		
Part # F-238512.XX		535 0081 10
A/C		544 0098 10
 A/C		FB 7PK1113
 -e		
 A/C		FB 7PK1795
 -e		
 A/C ; OPTION		FB 7PK1835
 -e ; OPTION		
16x		538 0374 10
 11 mm		420 0063 10
1x; 		428 0185 10
1x; 		428 0186 10

















FAG

 right ↓ down; →09.07		821 0558 10
 right ↓ down; 09.07→		821 0857 10
 left ↓ down; →09.07		821 0557 10
 left ↓ down; 09.07→		821 0855 10
 ; B001462→;  15 "		713 6307 90
 ; B000486→;  15 "		
 ; B000207→;  15 "		
 ; B000807→;  15 "		
 ; B000184→;  15 "		
 ;  16 "		
 84 mm		
 ; →B001461;  15 "		713 6308 00
 ; →B000485;  15 "		
 ; →B000206;  15 "		
 ; →B000806;  15 "		
 ; →B000183;  15 "		
 84 mm		
 ;  16 "		713 6307 80
 80 mm		
 ;  15 "		713 6308 10
 80 mm		
 right		818 0206 10
 left		818 0205 10
 ↓ down; →09.07		825 0166 10
 ↑ up 		825 0167 10
 ↑ up 		825 0280 10
 ↓ down; 09.07→		825 0300 10
		840 0198 10
 right		840 0878 10
 left		840 0877 10





















2.5 DTI (FD)
 G9U 720; G9U 724; G9U 754;
 (84kW)

10.01-



G5 ;  PK5.007 PK5.008 PK5.014 PK5.015	GearBOX	462 0202 10
G6 ;		
 PK6.019 PK6.020 PK6.029 PK6.030 PK6.069 PK6.070		
PK6.079 PK6.080		
→04.05;  PF1 ;  № 0##		624 3476 09
 PK5 ;  № 0##		624 3476 33
 PK6 ;  № 0##		
08.04→12.05;  SEMI ;  Easytronic PA6 ;  № 0##		
05.05→;  PK6 ;  № 3##		624 3476 34



		530 0198 10
		531 0548 10
		532 0313 20
 ;  G9T-754; A/C		529 0432 10
 ;  G9T-754; -e		
 A/C		529 0436 10
 -e		
 A/C		532 0333 10
 -e		
 A/C		532 0364 20
 -e		
 G9U 750 G9U 754		534 0317 10
Part # F-238512.XX		535 0081 10



			SCHAEFFLER
--	--	--	------------

OPEL

MOVANO A Box (F9)

2.5 DTI (FD)
 G9U 720; G9U 724; G9U 754;
 (84kW)

10.01-



	G9U720; A/C		544 0094 10
	G9U724; A/C		544 0098 10
	G9U754; A/C		544 0098 10
	G9T-720 G9T-722; A/C		FB 6PK1148
	G9T-720 G9T-722; -e		FB 6PK1795
	G9T-720 G9T-722; A/C		FB 6PK1795
	G9T-720 G9T-722; -e		FB 6PK1795
	G9U-754; A/C ; OPTION		FB 7PK1103
	G9U-754; -e ; OPTION		FB 7PK1145
	G9U-754; A/C		FB 7PK1145
	G9U-754; -e		FB 7PK1795
	G9T-754; A/C		FB 7PK1795
	G9T-754; -e		538 0374 10
	16x		420 0063 10
	11 mm		428 0185 10
	1x;		428 0186 10
	1x;		821 0558 10
	FAG right ↓ down; →09.07		821 0857 10
	right ↓ down; 09.07→		821 0557 10
	left ↓ down; →09.07		821 0855 10
	left ↓ down; 09.07→		821 0855 10
	; B001462→; 15 "		Set 713 6307 90
	; B000486→; 15 "		
	; B000207→; 15 "		
	; B000807→; 15 "		
	; B000184→; 15 "		
	; 16 "		
	84 mm		
	; →B001461; 15 "		Set 713 6308 00
	; →B000485; 15 "		
	; →B000206; 15 "		
	; →B000806; 15 "		
	; →B000183; 15 "		
	84 mm		
	; 16 "		Set 713 6307 80
	80 mm		
	; 15 "		Set 713 6308 10
	80 mm		
	; ABS		771 0292 30
	101,9 mm		
	right		818 0206 10
	left		818 0205 10
	↓ down; →09.07		825 0166 10
	↑ up		825 0167 10
	↑ up		825 0280 10
	↓ down; 09.07→		825 0300 10
			840 0198 10
	right		840 0878 10
	left		840 0877 10
			624 3476 34

3.0 DTI (FD)
 ZD3 200; ZD3 202; (100kW)

10.03-



	# F-228751.XX		535 0053 10
			FB 7PK1920
			538 0384 10
	FAG right ↓ down; →09.07		821 0558 10
	right ↓ down; 09.07→		821 0857 10
	left ↓ down; →09.07		821 0557 10
	left ↓ down; 09.07→		821 0855 10
	; B001462→; 15 "		Set 713 6307 90
	; B000486→; 15 "		
	; B000207→; 15 "		
	; B000807→; 15 "		
	; B000184→; 15 "		
	; 16 "		
	84 mm		



			SCHAEFFLER
--	---	--	-------------------

PEL

MOVANO A Box (F9)

3.0 DTI (FD)
 ZD3 200; ZD3 202; (100kW)

10.03-

FAG

→B001461; 15"		713 6308 00
→B000485; 15"		
→B000206; 15"		
→B000806; 15"		
→B000183; 15"		
84 mm		
16"		713 6307 80
80 mm		
15"		713 6308 10
80 mm		
right		818 0206 10
left		818 0205 10
↓ down; →09.07		825 0166 10
↑ up		825 0167 10
↑ up		825 0280 10
↓ down; 09.07 →		825 0300 10
		840 0198 10
right		840 0878 10
left		840 0877 10

MOVANO A Combi (X70)

1.9 DTI (JD)
 F9Q 772; F9Q 774; (60kW)

10.01-

LUK

G5; PK5.004 PK5.012 PK5.018 PK5.068 PK5.072	GearBOX	462 0155 10
G5; PK5.022	GearBOX	462 0202 10
G5; PK5.372	GearBOX	462 0203 10
→C039090		624 3087 09
→05.05; →C039090; PK5; № 0##		624 3087 33
06.05 →; →C039090; PK5.3##		624 3087 34
C039091 →		624 3312 09
→05.05; C039091 →; PK5; № 0##		624 3312 33
06.05 →; C039091 →; PK5.3##		624 3312 34

INA

		530 0196 10
		530 0196 30
		533 0087 20
; + ; →C029793; A/C		529 0118 10
; C029794 →; A/C		529 0124 10
; A/C		529 0427 10
;		
; A/C ; →C029793		532 0243 10
; A/C ; C029794 →		532 0364 20
; A/C		534 0142 30
# F-560843.XX F-556602.XX F-229643.XX		535 0030 10
# F-234637.XX		535 0048 10
A/C		544 0089 10
A/C		544 0101 10
A/C		544 0101 20
; A/C		FB 6PK1795
		538 0392 10











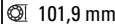

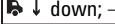
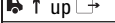
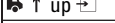
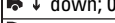













































FAG

right ↓ down; →09.07		821 0558 10
right ↓ down; 09.07 →		821 0857 10
left ↓ down; →09.07		821 0557 10
left ↓ down; 09.07 →		821 0855 10
; B001462 →; 15"		713 6307 90
; B000486 →; 15"		
; B000207 →; 15"		
; B000807 →; 15"		
; B000184 →; 15"		
; 16"		
84 mm		
→B001461; 15"		713 6308 00
→B000485; 15"		
→B000206; 15"		
→B000806; 15"		
→B000183; 15"		
84 mm		
16"		713 6307 80
80 mm		
15"		713 6308 10
80 mm		

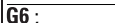

			SCHAEFFLER
--	--	--	-------------------

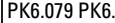
OPEL

MOVANO A Combi (X70)										
1.9 DTI (JD) F9Q 772; F9Q 774; (60kW)	10.01-	FAG	 ABS  101,9 mm  right  left  ↓ down; →09.07  ↑ up  ↑ up  ↓ down; 09.07→  right  left	 771 0292 30  818 0206 10  818 0205 10  825 0166 10  825 0167 10  825 0280 10  825 0300 10  840 0198 10  840 0878 10  840 0877 10  624 3476 09  624 3476 34						
			2.5 CDTI (JD) G9U 650; (74kW)	09.07-	LUK	 MANU;  PF6;  Nº 0## 	 530 0198 10  531 0548 10  532 0313 20  529 0437 10  532 0333 10  532 0364 20  532 0534 10  534 0181 10  534 0317 10  535 0081 10  544 0098 10  FB 7PK1113  FB 7PK1795  FB 7PK1835  538 0374 10  420 0063 10  428 0185 10  428 0186 10  821 0857 10  821 0855 10  713 6307 90  713 6308 00  713 6307 80  713 6308 10  818 0206 10  818 0205 10  825 0167 10  825 0280 10  825 0300 10  840 0198 10  840 0878 10  840 0877 10			
						2.5 DTI (JD) G9U 720; G9U 724; G9U 750; G9U 754; (84kW)	10.01-	LUK	 G5;  PK5.007 PK5.008 PK5.014 PK5.015  G6;  PK6.019 PK6.020 PK6.029 PK6.030 PK6.069 PK6.070 PK6.079 PK6.080	 GearBOX 462 0202 10

















































			<p>SCHAEFFLER</p>	
--	--	--	--------------------------	--

OPEL

MOVANO A Combi (X70)

2.5 DTI (JD)
 G9U 720; G9U 724; G9U 750; G9U 754; (84kW)

10.01-

	→04.05; PF1; № 0## PK5; № 0## PK6; № 0## 08.04→12.05; SEMI; Easytronic PA6; № 0## 05.05→; PK6; № 3##	 624 3476 09  624 3476 33  624 3476 34
	G9U-750 G9U-754; A/C G9U-750 G9U-754; -e A/C -e A/C -e A/C -e G9U 750 G9U 754 F-238512.XX G9U720; A/C G9U724; A/C G9U 750; A/C G9U 754; A/C G9T-720 G9T-722; A/C G9T-720 G9T-722; -e G9T-720 G9T-722; A/C G9T-720 G9T-722; -e G9U-750 G9U-754; A/C; OPTION G9U-750 G9U-754; -e; OPTION G9T-750 G9T-754; A/C G9T-750 G9T-754; -e 16x 11 mm 1x;  1x; 	 530 0198 10  531 0548 10  532 0313 20  529 0432 10  529 0436 10  532 0333 10  532 0364 20  534 0317 10  535 0081 10  544 0094 10  544 0098 10  FB 6PK1148  FB 6PK1795  FB 7PK1103  FB 7PK1795  538 0374 10  420 0063 10  428 0185 10  428 0186 10
FAG	right ↓ down; →09.07 right ↓ down; 09.07→ left ↓ down; →09.07 left ↓ down; 09.07→ B001462→; 15" B000486→; 15" B000207→; 15" B000807→; 15" B000184→; 15" 16" 84 mm →B001461; 15" →B000485; 15" →B000206; 15" →B000806; 15" →B000183; 15" 84 mm 16" 80 mm 15" 80 mm ABS 101,9 mm right left ↓ down; →09.07 ↑ up  ↑ up  ↓ down; 09.07→ right left	 821 0558 10  821 0857 10  821 0557 10  821 0855 10  Set 713 6307 90  Set 713 6308 00  Set 713 6307 80  Set 713 6308 10  771 0292 30  818 0206 10  818 0205 10  825 0166 10  825 0167 10  825 0280 10  825 0300 10  840 0198 10  840 0878 10  840 0877 10



















































			SCHAEFFLER
--	--	--	-------------------

OPEL

MOVANO A Combi (X70)

2.5 CDTi (JD)
 G9U 632; G9U 650; (88-107kW)

08.06-

		MANU ; PF6 ; N° 0##		624 3476 09	
				624 3476 34	
				530 0198 10	
				531 0548 10	
				532 0313 20	
				529 0437 10	
				532 0333 10	
				532 0364 20	
				532 0534 10	
				534 0181 10	
				534 0317 10	
				535 0081 10	
				544 0098 10	
				FB 7PK1113	
				FB 7PK1795	
				FB 7PK1835	
				538 0374 10	
				420 0063 10	
				16x	
				⊙ 11 mm	
				428 0185 10	
				428 0186 10	
	FAG		right ↓ down; →09.07		821 0558 10
			right ↓ down; 09.07→		821 0857 10
			left ↓ down; →09.07		821 0557 10
			left ↓ down; 09.07→		821 0855 10
			; B001462→; ⊙ 15"		713 6307 90
			; B000486→; ⊙ 15"		
			; B000207→; ⊙ 15"		
			; B000807→; ⊙ 15"		
		; B000184→; ⊙ 15"			
		; ⊙ 16"			
		⊙ 84 mm			
		→B001461; ⊙ 15"			
		→B000485; ⊙ 15"			
		→B000206; ⊙ 15"			
		→B000806; ⊙ 15"			
		→B000183; ⊙ 15"			
		⊙ 84 mm		713 6307 80	
		; ⊙ 16"			
		⊙ 80 mm		713 6308 10	
		; ⊙ 15"			
		⊙ 80 mm			
		right		818 0206 10	
		left		818 0205 10	
		↓ down; →09.07		825 0166 10	
	↑ up		825 0167 10		
	↑ up		825 0280 10		
	↓ down; 09.07→		825 0300 10		
			840 0198 10		
	right		840 0878 10		
	left		840 0877 10		
				624 3476 34	
		## F-228751.XX		535 0053 10	
				FB 7PK1920	
				538 0384 10	
	FAG		right ↓ down; →09.07		821 0558 10
			right ↓ down; 09.07→		821 0857 10
			left ↓ down; →09.07		821 0557 10
			left ↓ down; 09.07→		821 0855 10

3.0 DTi (JD)
 ZD3 200; ZD3 202; (100kW)

10.03-



			<p>SCHAEFFLER</p>
--	---	--	--------------------------

OPEL

MOVANO A Combi (X70)

3.0 DTi (JD)
 ZD3 200; ZD3 202; (100kW)

10.03-	FAG	B001462 →; 15" B000486 →; 15" B000207 →; 15" B000807 →; 15" B000184 →; 15" 16" 84 mm →B001461; 15" →B000485; 15" →B000206; 15" →B000806; 15" →B000183; 15" 84 mm 16" 80 mm 15" 80 mm right left ↓ down; →09.07 ↑ up ↑ up ↓ down; 09.07 → right left	Set 713 6307 90 Set 713 6308 00 Set 713 6307 80 Set 713 6308 10 818 0206 10 818 0205 10 825 0166 10 825 0167 10 825 0280 10 825 0300 10 840 0198 10 840 0878 10 840 0877 10
--------	------------	---	---

MOVANO A Dumptruck (X70)

2.5 DTi (ED, HD, UD0, UD4)
 G9U 754; (73kW)

10.03-	LUK INA FAG	G6 ; PK6.019 PK6.020 PK6.029 PK6.030 PK6.069 PK6.070 PK6.079 PK6.080 →12.05; PK5 ; № 0## 01.06 →; PK5 ; № 3## A/C ; A/C ; A/C ; A/C ; F-238512.XX A/C ; A/C ; OPTION ; ; OPTION ; A/C ; 16x 11 mm 1x 1x right ↓ down; →09.07 right ↓ down; 09.07 → left ↓ down; →09.07 left ↓ down; 09.07 → B001462 →; 15" B000486 →; 15" B000207 →; 15" B000807 →; 15" B000184 →; 15" 16" 84 mm	GearBOX 462 0202 10 624 3476 09 624 3476 33 624 3476 34 530 0198 10 531 0548 10 532 0313 20 529 0432 10 529 0436 10 532 0333 10 532 0364 20 535 0081 10 544 0098 10 FB 7PK1103 FB 7PK1795 538 0374 10 420 0063 10 428 0185 10 428 0186 10 821 0558 10 821 0857 10 821 0557 10 821 0855 10 Set 713 6307 90
--------	---------------------------	---	--



			SCHAEFFLER
--	--	--	-------------------

OPEL

MOVANO A Dumptruck (X70)

2.5 DTI (ED, HD, UD0, UD4)
 G9U 754; (73kW)

10.03-

FAG

→B001461; 15"
 →B000485; 15"
 →B000206; 15"
 →B000806; 15"
 →B000183; 15"

 713 6308 00

84 mm
 16"
 80 mm

 713 6307 80

15"
 80 mm

 713 6308 10

right

 818 0206 10

left

 818 0205 10

↓ down; →09.07

 825 0166 10

↑ up

 825 0167 10

↑ up

 825 0280 10

↓ down; 09.07→

 825 0300 10

 840 0198 10

right

 840 0878 10

left

 840 0877 10

LUK

MANU; PF6; № 0##

 624 3476 09

 624 3476 34



 530 0198 10

→09.10; A/C; OPTION

 531 0548 10

→09.10; e; OPTION

 532 0313 20

A/C

 529 0437 10

→09.10; A/C

 532 0333 10

09.10→; A/C

 532 0364 20

A/C

 532 0534 10

e

 534 0181 10

A/C

 534 0317 10

e

 534 0317 10

F-238512.XX

 535 0081 10

A/C

 544 0098 10

A/C

 FB 7PK1113

e

 FB 7PK1795

A/C

 FB 7PK1835

e

 538 0374 10

A/C; OPTION

 420 0063 10

e; OPTION

 428 0185 10

16x

 428 0186 10

11 mm

 821 0558 10

1x; 1

 821 0857 10

1x; 1

 821 0557 10

FAG

right ↓ down; →09.07

 821 0855 10

right ↓ down; 09.07→

 821 0855 10

left ↓ down; →09.07

 821 0855 10

left ↓ down; 09.07→

 821 0855 10

B001462→; 15"

 713 6307 90

B000486→; 15"

 713 6308 00

B000207→; 15"

 713 6307 80

B000807→; 15"

 713 6308 10

B000184→; 15"

 818 0206 10

16"

 818 0205 10

84 mm

→B001461; 15"

 713 6308 00

→B000485; 15"

 713 6307 80

→B000206; 15"

 713 6308 10

→B000806; 15"

 818 0206 10

→B000183; 15"

 818 0205 10

84 mm

16"

80 mm

15"

80 mm

right

left



			<p>SCHAEFFLER</p>
--	--	--	--------------------------

OPEL

MOVANO A Dumptruck (X70)

2.5 CDTI (ED, HD, UD0, UD4)
 G9U 632; G9U 650; (74-107kW)

08.06-

FAG

↓ down; →09.07		825 0166 10
↑ up □		825 0167 10
↑ up □		825 0280 10
↓ down; 09.07→		825 0300 10
right		840 0198 10
left		840 0878 10
left		840 0877 10

2.5 DTI (ED, HD, UD0, UD4)
 G9U 720; G9U 724; G9U 750; G9U 754; (84kW)

10.01-

LUK

G5 ; PK5.007 PK5.008 PK5.014 PK5.015	GearBOX	462 0202 10
G6 ;		
PK6.019 PK6.020 PK6.029 PK6.030 PK6.069 PK6.070		
PK6.079 PK6.080		
→04.05; PF1 ; № 0##		624 3476 09
PK5 ; № 0##		624 3476 33
PK6 ; № 0##		
08.04→12.05; SEMI ; Easytronic PA6 ; № 0##		
05.05→; PK6 ; № 3##		624 3476 34

INA

		530 0198 10
		531 0548 10
G9U-750 G9U-754; A/C		532 0313 20
G9U-750 G9U-754; -e		529 0432 10
A/C		529 0436 10
-e		
A/C		532 0333 10
-e		532 0364 20
A/C		534 0317 10
-e		
G9U 750 G9U 754		535 0081 10
F-238512.XX		
G9U720; A/C		544 0094 10
G9U724; A/C		544 0098 10
G9U750; A/C		544 0098 10
G9U754; A/C		
G9T-720 G9T-722; A/C		FB 6PK1148
G9T-720 G9T-722; -e		
G9T-720 G9T-722; A/C		FB 6PK1795
G9T-720 G9T-722; -e		
G9U-750 G9U-754; A/C ; OPTION		FB 7PK1103
G9U-750 G9U-754; -e ; OPTION		
G9T-750 G9T-754; A/C		FB 7PK1795
G9T-750 G9T-754; -e		

FAG

right ↓ down; →09.07		821 0558 10
right ↓ down; 09.07→		821 0857 10
left ↓ down; →09.07		821 0557 10
left ↓ down; 09.07→		821 0855 10
B001462→; 15"		713 6307 90
B000486→; 15"		
B000207→; 15"		
B000807→; 15"		
B000184→; 15"		
16"		
84 mm		
→B001461; 15"		713 6308 00
→B000485; 15"		
→B000206; 15"		
→B000806; 15"		
→B000183; 15"		
84 mm		
16"		713 6307 80
80 mm		
15"		713 6308 10
80 mm		











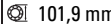
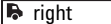

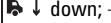
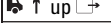

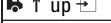

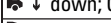
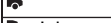
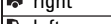











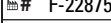
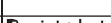
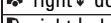
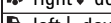
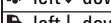

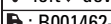

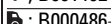

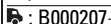

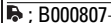

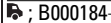

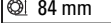

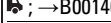

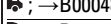

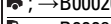

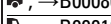

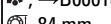
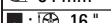

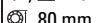

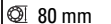
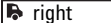

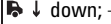

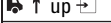

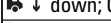

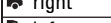











			SCHAEFFLER
--	--	--	-------------------











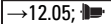
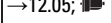
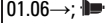
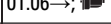





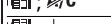
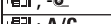
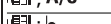
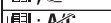
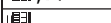
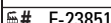

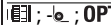





OPEL

MOVANO A Dumptruck (X70)

2.5 DTi (ED, HD, UD0, UD4) G9U 720; G9U 724; G9U 750; G9U 754; (84kW)	10.01-	FAG	 ; ABS  101,9 mm  right  left  ↓ down; →09.07  ↑ up   ↑ up   ↓ down; 09.07→  right  left	 771 0292 30  818 0206 10  818 0205 10  825 0166 10  825 0167 10  825 0280 10  825 0300 10  840 0198 10  840 0878 10  840 0877 10  624 3476 34			
			3.0 DTi (ED, HD, UD0, UD4) ZD3 200; ZD3 202; (100kW)	10.03-	LUK	 # F-228751.XX  right ↓ down; →09.07  right ↓ down; 09.07→  left ↓ down; →09.07  left ↓ down; 09.07→  ; B001462→;  15"  ; B000486→;  15"  ; B000207→;  15"  ; B000807→;  15"  ; B000184→;  15"  ;  16"  84 mm  ; →B001461;  15"  ; →B000485;  15"  ; →B000206;  15"  ; →B000806;  15"  ; →B000183;  15"  84 mm  ;  16"  80 mm  ;  15"  80 mm  right  left  ↓ down; →09.07  ↑ up   ↑ up   ↓ down; 09.07→  right  left	 535 0053 10  538 0384 10  821 0558 10  821 0857 10  821 0557 10  821 0855 10  713 6307 90  713 6308 00  713 6307 80  713 6308 10  818 0206 10  818 0205 10  825 0166 10  825 0167 10  825 0280 10  825 0300 10  840 0198 10  840 0878 10  840 0877 10

MOVANO A Platform/Chassis (X70)

2.5 DTi (ED, HD, UD0, UD4) G9U 754; (73kW)	10.03-	LUK	G6 ;  PK6.019 PK6.020 PK6.029 PK6.030 PK6.069 PK6.070 PK6.079 PK6.080 →12.05;  PK5 ;  № 0## 01.06→;  PK5 ;  № 3##	GearBOX 462 0202 10  624 3476 09  624 3476 33  624 3476 34	
			INA	 ; A/C  ; -e  ; A/C  ; e  ; A/C  ; e  ; A/C  ; e # F-238512.XX A/C  ; A/C ; OPTION  ; -e ; OPTION  ; A/C  ; e 16x  11 mm	 530 0198 10  531 0548 10  532 0313 20  529 0432 10  529 0436 10  532 0333 10  532 0364 20  535 0081 10  544 0098 10  FB 7PK1103  FB 7PK1795  538 0374 10  420 0063 10



			SCHAEFFLER
--	--	--	-------------------

OPEL



MOVANO A Platform/Chassis (X70)

2.5 DTi (ED, HD, UDO, UD4)
 G9U 754; (73kW)

10.03-





1x; 
 1x; 

 428 0185 10
 428 0186 10



 right ↓ down; →09.07

 821 0558 10

 right ↓ down; 09.07→



 821 0857 10

 left ↓ down; →09.07



 821 0557 10



 left ↓ down; 09.07→



 821 0855 10



 ; B001462→;  15 "

 **Set** 713 6307 90

 ; B000486→;  15 "



 ; B000207→;  15 "

 ; B000807→;  15 "



 ; B000184→;  15 "



 ;  16 "



 84 mm

 ; →B001461;  15 "

 **Set** 713 6308 00



 ; →B000485;  15 "

 ; →B000206;  15 "

 ; →B000806;  15 "



 ; →B000183;  15 "

 84 mm

 ;  16 "

 **Set** 713 6307 80

 80 mm

 ;  15 "

 **Set** 713 6308 10

 80 mm

 right



 818 0206 10

 left



 818 0205 10

 ↓ down; →09.07

 825 0166 10

 ↑ up 

 825 0167 10

 ↑ up 

 825 0280 10

 ↓ down; 09.07→

 825 0300 10

 right

 840 0198 10

 left



 840 0878 10

2.5 CDTi (ED, HD, UDO, UD4)
 G9U 632; G9U 650; (74-107kW)



08.06-





 MANU ;  PF6 ;  № 0##

 624 3476 09
 624 3476 34





 530 0198 10
 531 0548 10

 ; →09.10; A/C ; **OPTION**

 532 0313 20

 ; →09.10;  ; **OPTION**

 529 0437 10

 ; A/C

 532 0333 10

 ; →09.10; A/C

 532 0364 20

 ; 09.10→; A/C

 532 0534 10



 ; A/C

 534 0181 10

 ; 

 534 0317 10

 ; A/C

 ; 

 535 0081 10

 A/C

 544 0098 10

 ; A/C



 FB 7PK1113

 ; 

 FB 7PK1795

 ; A/C

 FB 7PK1835

 ;  ; **OPTION**

 538 0374 10

 ;  ; **OPTION**

 420 0063 10

16x

 11 mm

1x; 

 428 0185 10

1x; 

 428 0186 10



 right ↓ down; →09.07

 821 0558 10

 right ↓ down; 09.07→

 821 0857 10

 left ↓ down; →09.07

 821 0557 10

 left ↓ down; 09.07→





































 821 0855 10



			SCHAEFFLER
--	--	--	-------------------

OPEL

MOVANO A Platform/Chassis (X70)

2.5 CDTI (ED, HD, UD0, UD4) G9U 632; G9U 650; (74-107kW)	08.06-	FAG	B; B001462→; 15"	 713 6307 90	
			B; B000486→; 15"	 713 6308 00	
			B; B000207→; 15"		
			B; B000807→; 15"		
			B; B000184→; 15"		
			B; 16"		
			84 mm		
			→B001461; 15"		
			→B000485; 15"		
			→B000206; 15"		
			→B000806; 15"		
			→B000183; 15"		
			84 mm		
			16"		 713 6307 80
			80 mm		
			15"		 713 6308 10
			80 mm		
			right		 818 0206 10
			left		 818 0205 10
			↓ down; →09.07		 825 0166 10
↑ up	 825 0167 10				
↑ up	 825 0280 10				
↓ down; 09.07→	 825 0300 10				
	 840 0198 10				
right	 840 0878 10				
left	 840 0877 10				
2.5 DTI (ED, HD, UD0, UD4) G9U 720; G9U 724; G9U 750; G9U 754; (84kW)	10.01-	LUK	G5; PK5.007 PK5.008 PK5.014 PK5.015	GearBOX 462 0202 10	
			G6;		
			PK6.019 PK6.020 PK6.029 PK6.030 PK6.069 PK6.070 PK6.079 PK6.080		
			→04.05; PF1; № 0##		
			PK5; № 0##		
			PK6; № 0##		
			08.04→12.05; SEMI; Easytronic PA6; № 0##		
			05.05→; PK6; № 3##		
					 624 3476 09
			 624 3476 33		
			 624 3476 34		
			 530 0198 10		
			 531 0548 10		
			 532 0313 20		
			 529 0432 10		
			 529 0436 10		
			 532 0333 10		
			 532 0364 20		
			 534 0317 10		
	 535 0081 10				
	 544 0094 10				
	 544 0098 10				
	 FB 6PK1148				
	 FB 6PK1795				
	 FB 7PK1103				
	 FB 7PK1795				
	 538 0374 10				
	 420 0063 10				
	16x				
	11 mm				
	1x;				
	1x;				
FAG	right ↓ down; →09.07	 821 0558 10			
	right ↓ down; 09.07→	 821 0857 10			
	left ↓ down; →09.07	 821 0557 10			



			<p>SCHAEFFLER</p>
--	--	--	--------------------------

OPEL

MOVANO A Platform/Chassis (X70)

2.5 DTI (ED, HD, UD0, UD4)
 G9U 720; G9U 724; G9U 750; G9U 754; (84kW)

10.01-	FAG	left ↓ down; 09.07 → B001462 →; 15" B000486 →; 15" B000207 →; 15" B000807 →; 15" B000184 →; 15" 16" 84 mm → B001461; 15" → B000485; 15" → B000206; 15" → B000806; 15" → B000183; 15" 84 mm 16" 80 mm 15" 80 mm 101,9 mm right left ↓ down; →09.07 ↑ up ↑ up ↓ down; 09.07 → right left	821 0855 10 Set 713 6307 90 Set 713 6308 00 Set 713 6307 80 Set 713 6308 10 771 0292 30 818 0206 10 818 0205 10 825 0166 10 825 0167 10 825 0280 10 825 0300 10 840 0198 10 840 0878 10 840 0877 10
--------	------------	--	---

3.0 DTI (ED, HD, UD0, UD4)
 ZD3 200; ZD3 202; (100kW)

10.03-	LUK  FAG	# F-228751.XX right ↓ down; →09.07 right ↓ down; 09.07 → left ↓ down; →09.07 left ↓ down; 09.07 → B001462 →; 15" B000486 →; 15" B000207 →; 15" B000807 →; 15" B000184 →; 15" 16" 84 mm → B001461; 15" → B000485; 15" → B000206; 15" → B000806; 15" → B000183; 15" 84 mm 16" 80 mm 15" 80 mm right left ↓ down; →09.07 ↑ up ↑ up ↓ down; 09.07 → right left	624 3476 34 535 0053 10 FB 7PK1920 538 0384 10 821 0558 10 821 0857 10 821 0557 10 821 0855 10 Set 713 6307 90 Set 713 6308 00 Set 713 6307 80 Set 713 6308 10 818 0206 10 818 0205 10 825 0166 10 825 0167 10 825 0280 10 825 0300 10 840 0198 10 840 0878 10 840 0877 10
--------	---	---	--

MOVANO B Box (X62)

2.3 CDTI FWD (FV)
 M9T 670; M9T 672; M9T 676;
 M9T 678; M9T 680; M9T 870; M9T 876; (74-107kW)























































































































05.10-	LUK	MANU ; PF6 ; № 0## incl. ; incl. ; SAC MANU ; PF6 SEMI ; PA0 SAC	600 0235 00 626 3049 09
--------	------------	--	----------------------------



			SCHAEFFLER
--	--	--	-------------------

OPEL

MOVANO B Box (X62)







































































































































2.3 CDTI FWD (FV) M9T 670; M9T 672; M9T 676; M9T 678; M9T 680; M9T 870; M9T 876; (74-107kW)	05.10-		 MANU ;  PF6 ;  Nº 0##		626 3049 33
			SAC		415 0485 10
			incl. 		529 0317 10
			 ; A/C		529 0353 10
			 ; A/C 		532 0534 10
			 ; A/C 		534 0281 10
					535 0080 10
					535 0153 10
					538 0397 10
					420 0086 10
		16x		422 0078 10	
		 12 mm		558 0060 10	
		16x		559 0172 10	
		1x		559 0172 30	
		1x		821 0865 10	
		1x		821 0868 10	
		FAG  right		713 6450 40	
		 left		713 6450 50	
		 90 mm		818 0482 10	
		 80 mm		818 0475 10	
 ↔		825 0333 10			
 ↔		825 0332 10			
 right; 07.10→		840 0394 10			
 left		840 1143 10			
 right; →07.10		840 1142 10			
 ↔		626 3050 00			
 right		415 0490 10			
 left		529 0352 10			
2.3 CDTI RWD (FV) M9T 686; M9T 690; M9T 692; M9T 694; M9T 696; M9T 698; M9T 876; (74-107kW)	05.10-		 ZF4		626 3050 00
			incl. 		415 0490 10
			 ; A/C		529 0352 10
			 ; A/C 		529 0353 10
			 ; A/C 		532 0534 10
					534 0281 10
					535 0080 10
					535 0153 10
					420 0086 10
			16x		422 0078 10
		 12 mm		558 0060 10	
		16x		559 0172 10	
		1x		559 0172 30	
		1x		821 0865 10	
		1x		821 0868 10	
		FAG  right		713 6450 40	
		 left		713 6450 30	
		 90 mm		713 6451 60	
		 ; 		818 0482 10	
		 ; 		818 0475 10	
 90 mm		818 0492 10			
 ↔		825 0333 10			
 right; 07.10→		825 0332 10			
 left		840 0394 10			
 right; →07.10		840 1143 10			
 ↔		840 1142 10			
 right		600 0235 00			
 left		626 3049 09			
2.3 CDTI FWD (FV) M9T 870; (81kW)	02.12-		 MANU		626 3049 33
			incl.  ; incl.  ; SAC		626 3049 33
			SAC		415 0485 10



			<p>SCHAEFFLER</p>
--	--	--	--------------------------

OPEL

MOVANO B Box (X62)



















































































































<p>2.3 CDTI FWD (FV) M9T 870; (81kW)</p>	<p>02.12-</p>		<p>  ; A/C  ; A/C   ; A/C    16x  12 mm 16x  right  left   90 mm   80 mm   ↔  ↔  right  left  ↔  right  left </p>	<p>  529 0317 10  529 0353 10  532 0534 10  534 0281 10  535 0080 10  535 0153 10  538 0397 10  420 0086 10  422 0078 10  821 0865 10  821 0868 10   713 6450 40   713 6450 50  818 0482 10  818 0475 10  825 0333 10  825 0332 10  840 0394 10  840 1143 10  840 1142 10 </p>
<p>2.3 CDTI FWD (FV) M9T 704; (96kW)</p>	<p>11.16-</p>		<p> SAC  ; A/C  ; A/C   16x  12 mm 16x  right  left   90 mm   80 mm   ↔  ↔  ↔  right  left </p>	<p>  626 3049 33  529 0355 10  529 0356 10  532 0534 10  534 0281 10  535 0080 10  535 0153 10  821 0865 10  821 0868 10   713 6450 40   713 6450 50  818 0482 10  818 0475 10  840 0394 10  840 1143 10  840 1142 10 </p>
<p>2.3 CDTI RWD (FV) M9T 710; (96kW)</p>	<p>11.16-</p>		<p>  ; A/C  ; A/C   16x  12 mm 16x  right  left   90 mm   90 mm   ↔  ↔  ↔  ↔  right  left </p>	<p>  529 0354 10  529 0356 10  532 0534 10  534 0281 10  535 0080 10  535 0153 10  821 0865 10  821 0868 10   713 6450 40   713 6450 30   713 6451 60  818 0482 10  818 0475 10  818 0492 10  840 0394 10  840 1143 10  840 1142 10 </p>
<p>2.3 CDTI FWD (FV) M9T 702; M9T 716; (100-120kW)</p>	<p>05.14-</p>		<p> SAC  ; A/C  ; A/C   16x  12 mm 16x  right  left </p>	<p>  626 3049 33  529 0355 10  529 0356 10  532 0534 10  534 0281 10  535 0080 10  535 0153 10 </p>



			SCHAEFFLER
--	--	--	-------------------

OPEL

MOVANO B Box (X62)



























































































2.3 CDTI FWD (FV) M9T 702; M9T 716; (100-120kW)	05.14-	 FAG	16x		538 0397 10			
			 12 mm		420 0086 10			
			16x		422 0078 10			
			 right		821 0865 10			
			 left		821 0868 10			
				 Set	713 6450 40			
			 90 mm		713 6450 50			
			 80 mm		713 6450 50			
			 ↔		818 0482 10			
			 ↔		818 0475 10			
			 right		825 0333 10			
			 left		825 0332 10			
			 ↔		840 0394 10			
			 right		840 1143 10			
			 left		840 1142 10			
			2.3 CDTI RWD (FV) M9T 700; M9T 702; (100kW)	05.14-	 LUK  FAG	M9T-702		626 3049 09
						SAC		
						 ;  M9T 700; A/C		529 0354 10
 ;  M9T 702; A/C		529 0355 10						
 ; A/C		529 0356 10						
		532 0534 10						
		534 0281 10						
# F-236675.XX F-561464.XX		535 0080 10						
# F-552305.XX		535 0153 10						
16x		420 0086 10						
 12 mm								
16x		422 0078 10						
 right		821 0865 10						
 left		821 0868 10						
	 Set	713 6450 40						
 90 mm		713 6450 30						
 ; 	 Set	713 6451 60						
 90 mm								
 ↔		818 0482 10						
 ↔ ; 		818 0475 10						
 ↔ ; 		818 0492 10						
 right		825 0333 10						
 left		825 0332 10						
 ↔		840 0394 10						
 right		840 1143 10						
 left		840 1142 10						
2.3 CDTI FWD (FV) M9T 716; M9T 880; (110kW)	01.13-	  LUK  FAG	SAC		626 3049 33			
			incl. 		415 0485 10			
			 ; A/C		529 0317 10			
			 ; A/C					
			 ; A/C		529 0353 10			
					532 0534 10			
					534 0281 10			
			# F-236675.XX F-561464.XX		535 0080 10			
			# F-552305.XX		535 0153 10			
					538 0397 10			
			16x		420 0086 10			
			 12 mm					
			16x		422 0078 10			
			 right		821 0865 10			
			 left		821 0868 10			
				 Set	713 6450 40			
			 90 mm		713 6450 50			
			 80 mm					
↔		818 0482 10						
↔		818 0475 10						
right		825 0333 10						
left		825 0332 10						
↔		840 0394 10						



			<p>SCHAEFFLER</p>
--	--	--	--------------------------

OPEL

MOVANO B Box (X62)

<p>2.3 CDTI FWD (FV) M9T 716; M9T 880; (110kW)</p>	<p>01.13-</p>	<p>FAG right</p>	<p> 840 1143 10</p>
		<p>left</p>	<p> 840 1142 10</p>
<p>2.3 CDTI RWD (FV) M9T 694; M9T 696; M9T 698; (110kW)</p>	<p>01.13-</p>	<p>LUK ZF4</p>	<p> 626 3050 00</p>
		<p>incl. </p>	<p> 415 0490 10</p>
		<p> ; A/C</p>	<p> 529 0352 10</p>
		<p> ; A/C</p>	<p> 529 0353 10</p>
		<p> ; A/C</p>	<p> 532 0534 10</p>
		<p></p>	<p> 534 0281 10</p>
		<p>Part # F-236675.XX F-561464.XX</p>	<p> 535 0080 10</p>
		<p>Part # F-552305.XX</p>	<p> 535 0153 10</p>
		<p>16x</p>	<p> 420 0086 10</p>
		<p> 12 mm</p>	<p> 422 0078 10</p>
		<p>16x</p>	<p> 821 0865 10</p>
		<p>FAG right</p>	<p> 821 0868 10</p>
		<p>left</p>	<p> Set 713 6450 40</p>
		<p> 90 mm</p>	<p> Set 713 6450 30</p>
		<p></p>	<p> Set 713 6451 60</p>
		<p> 90 mm</p>	<p> 818 0482 10</p>
		<p></p>	<p> 818 0475 10</p>
		<p></p>	<p> 818 0492 10</p>
		<p> right</p>	<p> 825 0333 10</p>
		<p>left</p>	<p> 825 0332 10</p>
		<p></p>	<p> 840 0394 10</p>
		<p>right</p>	<p> 840 1143 10</p>
		<p>left</p>	<p> 840 1142 10</p>
<p>2.3 CDTI RWD (FV) M9T 700; (120kW)</p>	<p>05.14-</p>	<p> ; A/C</p>	<p> 529 0354 10</p>
		<p> ; A/C</p>	<p> 529 0356 10</p>
		<p></p>	<p> 532 0534 10</p>
		<p></p>	<p> 534 0281 10</p>
		<p>Part # F-236675.XX F-561464.XX</p>	<p> 535 0080 10</p>
		<p>Part # F-552305.XX</p>	<p> 535 0153 10</p>
		<p>16x</p>	<p> 420 0086 10</p>
		<p> 12 mm</p>	<p> 422 0078 10</p>
		<p>16x</p>	<p> 821 0865 10</p>
		<p>FAG right</p>	<p> 821 0868 10</p>
		<p>left</p>	<p> Set 713 6450 40</p>
		<p> 90 mm</p>	<p> Set 713 6450 30</p>
		<p></p>	<p> Set 713 6451 60</p>
		<p> 90 mm</p>	<p> 818 0482 10</p>
		<p></p>	<p> 818 0475 10</p>
		<p></p>	<p> 818 0492 10</p>
		<p> right</p>	<p> 825 0333 10</p>
		<p>left</p>	<p> 825 0332 10</p>
		<p></p>	<p> 840 0394 10</p>
		<p>right</p>	<p> 840 1143 10</p>
		<p>left</p>	<p> 840 1142 10</p>
<p>2.3 CDTI FWD (FV) M9T 706; (125kW)</p>	<p>11.16-</p>	<p>LUK SAC</p>	<p> 626 3049 09</p>
		<p> ; A/C</p>	<p> 529 0355 10</p>
		<p> ; A/C</p>	<p> 529 0356 10</p>
		<p>Part # F-236675.XX F-561464.XX</p>	<p> 535 0080 10</p>
		<p>Part # F-552305.XX</p>	<p> 535 0153 10</p>
		<p>FAG right</p>	<p> 821 0865 10</p>
		<p>left</p>	<p> 821 0868 10</p>
		<p> 90 mm</p>	<p> Set 713 6450 40</p>
		<p></p>	<p> Set 713 6450 50</p>
		<p> 80 mm</p>	<p> 818 0482 10</p>
		<p></p>	<p> 818 0475 10</p>
		<p></p>	<p> 840 0394 10</p>







































































































































			SCHAEFFLER
--	--	--	-------------------

OPEL

MOVANO B Box (X62)

2.3 CDTI FWD (FV) M9T 706; (125kW)	11.16-	FAG	 right  left	 840 1143 10  840 1142 10
---------------------------------------	--------	------------	---	--

MOVANO B Bus

2.3 CDTI FWD (JV) M9T 670; M9T 672; M9T 676; (74kW)	12.10-	LUK	 PF6 incl.  ; incl.  ; SAC	 600 0235 00
			 MANU;  PF6	 626 3049 09
			 SEMI;  PA0	
			SAC	
			 PF6.0##	 626 3049 33
			SAC	
			incl. 	 415 0485 10
			  A/C	 529 0317 10
			  A/C 	 529 0353 10
			  A/C 	 532 0534 10
		  A/C 	 534 0281 10	
		  A/C 	 535 0080 10	
		  A/C 	 535 0153 10	
		  A/C 	 538 0397 10	
		  A/C 	 420 0086 10	
		16x  12 mm	 422 0078 10	
		16x	 558 0060 10	
		1x	 559 0172 10	
		1x	 559 0172 30	
		FAG		
 right	 821 0865 10			
 left	 821 0868 10			
 90 mm	 Set 713 6450 40			
 80 mm	 Set 713 6450 50			
 ↔	 818 0482 10			
 ↔	 818 0475 10			
 right	 825 0333 10			
 left	 825 0332 10			
 ↔	 840 0394 10			
 right	 840 1143 10			
 left	 840 1142 10			
  A/C	 529 0317 10			
  A/C 	 529 0353 10			
  A/C 	 532 0534 10			
  A/C 	 534 0281 10			
  A/C 	 535 0080 10			
  A/C 	 535 0153 10			
  A/C 	 538 0397 10			
  A/C 	 420 0086 10			
16x  12 mm	 422 0078 10			
16x	 558 0060 10			
FAG				
 right	 821 0865 10			
 left	 821 0868 10			
 90 mm	 Set 713 6450 40			
 80 mm	 Set 713 6450 50			
 ↔	 818 0482 10			
 ↔	 818 0475 10			
right	825 0333 10			
left	825 0332 10			
↔	840 0394 10			
right	840 1143 10			
left	840 1142 10			
2.3 CDTI FWD (JV) M9T 670; M9T 672; M9T 676; M9T 678; M9T 680; M9T 870; M9T 876; (92-107kW)	12.10-	LUK	 MANU;  PF6;  N° 0## incl.  ; incl.  ; SAC	 600 0235 00
			 MANU;  PF6	 626 3049 09
			 SEMI;  PA0	
			SAC	
 MANU;  PF6;  N° 0##	 626 3049 33			
SAC				















































			SCHAEFFLER
--	--	--	-------------------

OPEL

MOVANO B Bus









































2.3 CDTI FWD (JV)
 M9T 670; M9T 672; M9T 676;
 M9T 678; M9T 680; M9T 870; M9T
 876; (92-107kW)

12.10-

	incl. 		415 0485 10
	 ; A/C		529 0317 10
	 ; A/C 		529 0353 10
			532 0534 10
			534 0281 10
	Part # F-236675.XX F-561464.XX		535 0080 10
	Part # F-552305.XX		535 0153 10
			538 0397 10
	16x		420 0086 10
	 12 mm		
	16x		422 0078 10
	1x		558 0060 10
	1x		559 0172 10
	1x		559 0172 30
FAG	 right		821 0865 10
	 left		821 0868 10
			713 6450 40
	 90 mm		713 6450 50
	 80 mm		
			818 0482 10
			818 0475 10
	 right		825 0333 10
	 left		825 0332 10
			840 0394 10
	 right		840 1143 10
	 left		840 1142 10

























2.3 CDTI FWD (JV)
 M9T 702; M9T 716; (100-120kW)

05.14-

	SAC		626 3049 33
	 ; A/C		529 0355 10
	 ; A/C		529 0356 10
			532 0534 10
			534 0281 10
	Part # F-236675.XX F-561464.XX		535 0080 10
	Part # F-552305.XX		535 0153 10
			538 0397 10
	16x		420 0086 10
	 12 mm		
	16x		422 0078 10
FAG	 right		821 0865 10
	 left		821 0868 10
			713 6450 40
	 90 mm		713 6450 50
	 80 mm		
			818 0482 10
			818 0475 10
	 right		825 0333 10
	 left		825 0332 10
			840 0394 10
	 right		840 1143 10
	 left		840 1142 10

2.3 CDTI FWD (JV)
 M9T 716; M9T 880; (110kW)

01.13-







































	SAC		626 3049 33
	incl. 		415 0485 10
	 ; A/C		529 0317 10
	 ; A/C 		529 0353 10
			532 0534 10
			534 0281 10
	Part # F-236675.XX F-561464.XX		535 0080 10
	Part # F-552305.XX		535 0153 10
			538 0397 10
	16x		420 0086 10
	 12 mm		
	16x		422 0078 10
FAG	 right		821 0865 10
	 left		821 0868 10



































































			SCHAEFFLER
--	--	--	-------------------

OPEL

MOVANO B Bus

2.3 CDTI FWD (JV) M9T 716; M9T 880; (110kW)	01.13-	FAG	  713 6450 40
			 90 mm
			  713 6450 50
			 80 mm
			 ↔
			 ↔
			 right
			 left
			 ↔
			 right
			 left
			  535 0080 10
			 M9T*
			 # F-236675.XX F-561464.XX
 M9T*			
 # F-552305.XX			
 16x			
 12 mm			
 16x			
FAG	 right		
	 left		
	  713 6450 40		
	 90 mm		
	  713 6450 50		
	 80 mm		
	 ↔		
	 ↔		
	 right		
	 left		
	 ↔		
	 right		
	 left		
	  840 1142 10		

MOVANO B Kipper (X62)

































2.3 CDTI FWD (HV, UV, UV, HV) M9T 702; M9T 704; (96-120kW)	05.14-	LUK	 SAC
			 ; A/C
			 ; A/C
			  529 0355 10
			  529 0356 10
			  532 0534 10
			  534 0281 10
			 # F-236675.XX F-561464.XX
			 # F-552305.XX
			  535 0080 10
			  535 0153 10
			  713 6450 40
			 90 mm
			 80 mm
FAG	  713 6450 50		
	 ; A/C		
	 ; A/C		
	  529 0354 10		
	  529 0356 10		
	  532 0534 10		
	  534 0281 10		
	 # F-236675.XX F-561464.XX		
	 # F-552305.XX		
	  535 0080 10		
	  535 0153 10		
	  713 6450 40		
	 90 mm		
	  713 6450 30		
  713 6451 60			
 90 mm			
FAG	  713 6450 40		
	 90 mm		
	  713 6450 50		
	 80 mm		
	 ; A/C		
	 ; A/C		
	 ; A/C		
	  529 0317 10		
	  529 0353 10		
	  532 0534 10		
	  534 0281 10		
	 # F-236675.XX F-561464.XX		
	# F-552305.XX		
	535 0080 10		
535 0153 10			
713 6450 40			
90 mm			
713 6450 50			
80 mm			
FAG	; A/C		
	; A/C		
	; A/C		
529 0352 10			
529 0353 10			

























































































			SCHAEFFLER
--	--	--	-------------------

OPEL

MOVANO B Kipper (X62)

2.3 CDTI RWD (UV, HV) M9T 694; M9T 696; M9T 698; (107kW)	05.10-		 		532 0534 10
			 		534 0281 10
		FAG	 # F-236675.XX F-561464.XX		535 0080 10
			 # F-552305.XX		535 0153 10
			 90 mm		713 6450 40
			 		713 6450 30
2.3 CDTI FWD (UV, HV) M9T 706; (125kW)	11.16-		 ; A/C		529 0355 10
			 ; A/C		529 0356 10
		FAG			532 0534 10
			 # F-236675.XX F-561464.XX		534 0281 10
			 # F-552305.XX		535 0080 10
			 90 mm		535 0153 10
 80 mm		713 6450 40			
		713 6450 50			

MOVANO B Platform/Chassis (X62)

















































































































2.3 CDTI FWD (EV, HV, UV) M9T 670; M9T 672; M9T 676; M9T 678; M9T 680; M9T 876; (74-107kW)	05.10-		 MANU ;  PF6 ;  N° 0##		600 0235 00					
			incl.  ; incl.  ; SAC		626 3049 09					
			 MANU ;  PF6							
			 SEMI ;  PA0							
			SAC							
			 MANU ;  PF6 ;  N° 0##		626 3049 33					
					incl. 		415 0485 10			
					 ; A/C		529 0317 10			
					 ; A/C		529 0353 10			
					 ; A/C		532 0534 10			
							534 0281 10			
					 # F-236675.XX F-561464.XX		535 0080 10			
					 # F-552305.XX		535 0153 10			
					16x		538 0397 10			
					 12 mm		420 0086 10			
					16x		422 0078 10			
					1x		558 0060 10			
					1x		559 0172 10			
					1x		559 0172 30			
					FAG			 right		821 0865 10
								 left		821 0868 10
								 90 mm		713 6450 40
								 80 mm		713 6450 50
								 ↔		818 0482 10
 ↔		818 0475 10								
 right; 07.10→		825 0333 10								
 left		825 0332 10								
 right; →07.10										
 ↔		840 0394 10								
 right		840 1143 10								
 left		840 1142 10								
			 ZF4		626 3050 00					
			incl. 		415 0490 10					
						 ; A/C		529 0352 10		
						 ; A/C		529 0353 10		
						 ; A/C		532 0534 10		
								534 0281 10		
 # F-236675.XX F-561464.XX		535 0080 10								
 # F-552305.XX		535 0153 10								
16x		420 0086 10								
 12 mm										
16x		422 0078 10								



			SCHAEFFLER
--	--	--	-------------------

OPEL

MOVANO B Platform/Chassis (X62)

2.3 CDTI RWD (EV, HV, UV) M9T 690; M9T 692; M9T 694; M9T 696; M9T 698; M9T 876; (74-107kW)	05.10-		1x		558 0060 10	
			1x		559 0172 10	
			1x		559 0172 30	
		FAG		right		821 0865 10
				left		821 0868 10
						713 6450 40
				 90 mm		713 6450 30
				 ; 		713 6451 60
				 90 mm		
						818 0482 10
				 ↔ ; 		818 0475 10
				 ↔ ; 		818 0492 10
				right; 07.10→		825 0333 10
				left		825 0332 10
right; →07.10						
		840 0394 10				
right		840 1143 10				
left		840 1142 10				
2.3 CDTI FWD (EV, HV, UV) M9T 870; (81kW)	05.14-		 ; A/C		529 0317 10	
			 ; A/C			
			 ; A/C		529 0353 10	
				532 0534 10		
				534 0281 10		
		 # F-236675.XX F-561464.XX		535 0080 10		
		 # F-552305.XX		535 0153 10		
		16x		538 0397 10		
		 12 mm		420 0086 10		
		16x		422 0078 10		
		FAG		right		821 0865 10
				left		821 0868 10
						713 6450 40
				 90 mm		713 6450 50
 80 mm						
				818 0482 10		
 ↔				818 0475 10		
right				825 0333 10		
left				825 0332 10		
				840 0394 10		
right				840 1143 10		
left		840 1142 10				
2.3 CDTI FWD (EV, HV, UV) M9T 704; (96kW)	11.16-		SAC		626 3049 33	
				 ; A/C		529 0355 10
				 ; A/C		529 0356 10
					532 0534 10	
				534 0281 10		
		 # F-236675.XX F-561464.XX		535 0080 10		
		 # F-552305.XX		535 0153 10		
		FAG		right		821 0865 10
				left		821 0868 10
						713 6450 40
				 90 mm		713 6450 50
				 80 mm		
						818 0482 10
				 ↔ ; 		818 0475 10
right				825 0333 10		
left				825 0332 10		
				840 0394 10		
right				840 1143 10		
left		840 1142 10				
2.3 CDTI RWD (EV, HV, UV) M9T 710; (96kW)	11.16-		 ; A/C		529 0354 10	
			 ; A/C		529 0356 10	
					532 0534 10	
				534 0281 10		
		 # F-236675.XX F-561464.XX		535 0080 10		































			SCHAEFFLER
--	---	--	-------------------

OPEL

MOVANO B Platform/Chassis (X62)







































2.3 CDTI RWD (EV, HV, UV)
 M9T 710; (96kW)

11.16-

	№# F-552305.XX		535 0153 10
FAG	 right		821 0865 10
	 left		821 0868 10
	 90 mm		713 6450 40
	 90 mm		713 6450 30
	 90 mm		713 6451 60
	 ↔		818 0482 10
	 ↔		818 0475 10
	 ↔		818 0492 10
	 right		825 0333 10
	 left		825 0332 10
	 ↔		840 0394 10
	 right		840 1143 10
	 left		840 1142 10









































2.3 CDTI FWD (EV, HV, UV)
 M9T 702; M9T 716; (100-120kW)

05.14-

	SAC		626 3049 33	
	 ; A/C		529 0355 10	
	 ; A/C		529 0356 10	
			532 0534 10	
			534 0281 10	
	№# F-236675.XX F-561464.XX		535 0080 10	
	№# F-552305.XX		535 0153 10	
			538 0397 10	
	16x		420 0086 10	
	 12 mm			
	16x		422 0078 10	
	FAG	 right		821 0865 10
		 left		821 0868 10
		 90 mm		713 6450 40
		 80 mm		713 6450 50
 ↔			818 0482 10	
 ↔			818 0475 10	
 right			825 0333 10	
 left			825 0332 10	
 ↔			840 0394 10	
 right			840 1143 10	
 left			840 1142 10	

2.3 CDTI RWD (EV, HV, UV)
 M9T 700; (100-120kW)

05.14-

	 ; A/C		529 0354 10	
	 ; A/C		529 0356 10	
			532 0534 10	
			534 0281 10	
	№# F-236675.XX F-561464.XX		535 0080 10	
	№# F-552305.XX		535 0153 10	
	16x		420 0086 10	
	 12 mm			
	16x		422 0078 10	
	FAG	 right		821 0865 10
		 left		821 0868 10
		 90 mm		713 6450 40
		 90 mm		713 6450 30
		 90 mm		713 6451 60
 ↔			818 0482 10	
 ↔			818 0475 10	
 ↔			818 0492 10	
 right			825 0333 10	
 left			825 0332 10	
 ↔			840 0394 10	
 right			840 1143 10	
 left			840 1142 10	

2.3 CDTI FWD (EV, HV, UV)
 M9T 716; M9T 880; (110kW)

01.13-

	SAC		626 3049 33
	incl. 		415 0485 10



			SCHAEFFLER
--	--	--	------------

OPEL

MOVANO B Platform/Chassis (X62)

<p>2.3 CDTI FWD (EV, HV, UV) M9T 716; M9T 880; (110kW)</p>	<p>01.13-</p>	<p></p>	<p> ; A/C ; A/C ; A/C # F-236675.XX F-561464.XX # F-552305.XX 16x 12 mm 16x right left 90 mm 80 mm ↔ ↔ right left ↔ right left</p>	<p> 529 0317 10 529 0353 10 532 0534 10 534 0281 10 535 0080 10 535 0153 10 538 0397 10 420 0086 10 422 0078 10 821 0865 10 821 0868 10 Set 713 6450 40 Set 713 6450 50 818 0482 10 818 0475 10 825 0333 10 825 0332 10 840 0394 10 840 1143 10 840 1142 10</p>
<p>2.3 CDTI RWD (EV, HV, UV) M9T 694; M9T 696; M9T 698; (110kW)</p>	<p>01.13-</p>	<p></p>	<p> ZF4 incl. ; A/C ; A/C ; A/C # F-236675.XX F-561464.XX # F-552305.XX 16x 12 mm 16x right left 90 mm ; ; 90 mm ↔ ↔ ; ↔ ; right left ↔ right left</p>	<p> 626 3050 00 415 0490 10 529 0352 10 529 0353 10 532 0534 10 534 0281 10 535 0080 10 535 0153 10 420 0086 10 422 0078 10 821 0865 10 821 0868 10 Set 713 6450 40 Set 713 6450 30 Set 713 6451 60 818 0482 10 818 0475 10 818 0492 10 825 0333 10 825 0332 10 840 0394 10 840 1143 10 840 1142 10</p>
<p>2.3 CDTI FWD (EV, HV, UV) M9T 706; (125kW)</p>	<p>11.16-</p>	<p></p>	<p>SAC ; A/C ; A/C # F-236675.XX F-561464.XX # F-552305.XX right left 90 mm 80 mm ↔ ↔ ; right left</p>	<p> 626 3049 09 529 0355 10 529 0356 10 532 0534 10 534 0281 10 535 0080 10 535 0153 10 821 0865 10 821 0868 10 Set 713 6450 40 Set 713 6450 50 818 0482 10 818 0475 10 825 0333 10 825 0332 10</p>



			SCHAEFFLER
--	---	--	-------------------

OPEL

MOVANO B Platform/Chassis (X62)

2.3 CDTI FWD (EV, HV, UV) M9T 706; (125kW)	11.16-	FAG	↔		840 0394 10
			right		840 1143 10
			left		840 1142 10

VIVARO A Box (F7)

1.9 DI (F7) F9Q 762; (60kW)	08.01-	LUK	G5 ; PK5.369	GearBOX	462 0203 10
			→ C039090		624 3087 09
			→ C039090; PK5.0##		624 3087 33
			→ C039090; PK5		624 3087 34
			C039091 →		624 3312 09
			C039091 →; PK5.0##		624 3312 33
			C039091 →; PK5.3##		624 3312 34
					530 0196 10
					530 0196 30
					533 0087 20
			; + ; → 02.02; A/C		529 0118 10
			; 02.02 →; A/C		529 0124 10
			; A/C		529 0427 10
			; -e		
			; → 02.02		532 0243 10
			; A/C		532 0333 10
			; 02.02 →		532 0364 20
			; A/C		534 0142 30
			# F-560843.XX F-556602.XX F-229643.XX		535 0030 10
			# F-234637.XX		535 0048 10
			A/C		544 0089 10
			A/C		544 0101 10
			A/C		544 0101 20
			; A/C		FB 6PK1795
					538 0392 10
		FAG	→ 6V699999; 6Y999999; right		821 0490 10
			right; 7V600001; 7Y000001 →		821 0822 10
			→ 6V699999; 6Y999999; left		821 0489 10
			left; 7V600001; 7Y000001 →		821 0821 10
			; ABS ; → 3V613233		713 6441 20
			86 mm		
			; ABS ; → 3V613233		713 6441 30
			86 mm		
			; 3V613234 →		713 6442 90
			88 mm		
			68 mm		713 6441 40
			left		771 0507 30
					815 0068 30
			↔		818 0207 10
					825 0260 10
			7V621198 7Y721613 →;		825 0261 10
					840 0274 10
			right		840 0880 10
			left		840 0879 10
		RUVILLE			755321

1.9 DTI (F7)

F9Q 760; (74kW)	08.01-	LUK	G6 ; PK6.008 PK6.021 PK6.023 PK6.025	GearBOX	462 0155 10
			G6 ; PK6.371 PK6.373	GearBOX	462 0203 10
			→ C092128		624 3087 09
			→ 05.05; → C092128; PK5; № 0##		624 3087 33
			→ 05.05; → C092128; PK6; № 0##		
			→ 05.05; → C092128; SEMI; Easytronic PA6; № 0##		
			06.05 →; → C092128; PK5; № 3##		624 3087 34
			06.05 →; → C092128; PK6; № 3##		
			06.05 →; → C092128; PF6; № 0##		
			C092129 →		624 3312 09
			→ 05.05; C092129 →; PK5; № 0##		624 3312 33
			→ 05.05; C092129 →; PK6; № 0##		
			→ 05.05; C092129 →; SEMI; Easytronic PA6; № 0##		
			06.05 →; C092129 →; PK5.3##		624 3312 34
			06.05 →; C092129 →; PK6; № 3##		
			06.05 →; C092129 →; PF6; № 0##		
					530 0196 10
					530 0196 30



			SCHAEFFLER
--	--	--	-------------------













































































OPEL

VIVARO A Box (F7)

1.9 DTI (F7)
 F9Q 760; (74kW)

08.01-







































































	; +  ; →02.02; A/C		533 0087 20
	; 02.02 →; A/C		529 0118 10
	; A/C		529 0124 10
	; -e		529 0427 10
	; →02.02		532 0243 10
	; A/C		532 0333 10
	; 02.02 →		532 0364 20
	; A/C		534 0142 30
	▬# F-560843.XX F-556602.XX F-229643.XX		535 0030 10
	▬# F-234637.XX		535 0048 10
	A/C		544 0089 10
	A/C		544 0101 10
	A/C		544 0101 20
	; A/C		FB 6PK1795
			538 0392 10
FAG	 →6V699999; 6Y999999;  right		821 0490 10
	 right;  7V600001; 7Y000001 →		821 0822 10
	 →6V699999; 6Y999999;  left		821 0489 10
	 left;  7V600001; 7Y000001 →		821 0821 10
	 ; ABS;  →3V613233		713 6441 20
	 86 mm		713 6441 30
	 ; ABS;  →3V613233		713 6441 30
	 86 mm		713 6442 90
	 ;  3V613234 →		713 6442 90
	 88 mm		713 6441 40
	 68 mm		771 0507 30
	 left		815 0068 30
	 ↔		818 0207 10
	 ↔		825 0260 10
	 7V621198 7Y721613 →; 		825 0261 10
	 right		840 0274 10
	 left		840 0880 10
	 left		840 0879 10
RUVILLE			755321

2.0 CDTI (F7)
 M9R 630; M9R 780; M9R 782;
 M9R 786; (66kW)

08.06-



	→02.14;  PF6.0##		624 3476 09
			624 3476 34
			532 0534 10
	▬# F-236675.XX F-561464.XX		534 0281 10
	; A/C; PTO;  C012568 →;  M9R786		535 0080 10
	; PTO; A/C		FB 7PK1685
	; PTO;  M9R786;  →C012567; A/C		FB 7PK1741
	; A/C; PTO; # OE 93161809 4431667		FB 7PK1973
	; A/C; PTO		FB 7PK2000
	; PTO; A/C; # OE 93198427 4434866		538 0397 10
	16x		420 0086 10
	 12 mm		422 0078 10
	16x		558 0059 10
	1x		559 0171 10
	1x		559 0171 30
	1x		821 0490 10
FAG	 →6V699999; 6Y999999;  right		821 0822 10
	 right;  7V600001; 7Y000001 →		821 0489 10
	 →6V699999; 6Y999999;  left		821 0821 10
	 left;  7V600001; 7Y000001 →		713 6441 20
	 ; ABS;  →3V613233		713 6441 30
	 86 mm		713 6442 90
	 ; ABS;  →3V613233		713 6442 90
	 86 mm		713 6441 40
	 ;  3V613234 →		713 6441 40
	 88 mm		815 0068 30
	 68 mm		818 0207 10
	 ↔		



			SCHAEFFLER
--	--	--	-------------------























































































































































OPEL

VIVARO A Box (F7)

2.0 CDTI (F7)
 M9R 630; M9R 780; M9R 782;
 M9R 786; (66kW)

2.0 CDTI (F7)
 M9R 630; M9R 692; M9R 780;
 M9R 784; M9R 786; M9R 788; (84kW)































































































































2.0 ECOTEC (F7)
 F4R 820; (86kW)

08.06-	FAG	  7V621198 7Y721613→;   right  left	 825 0260 10  825 0261 10  840 0274 10  840 0880 10  840 0879 10
08.06-	LUK	→02.14;  PF6.0##	 624 3476 09  624 3476 34
		 ; →07.14;  M9R 692  ; →07.14;  M9R 780  ; →07.14;  M9R 784  ; →07.14;  M9R 786  ; →07.14;  M9R 788    # F-236675.XX F-561464.XX  ;  A/C ;  PTO ;  C012568→;  M9R786  ;  PTO ;  A/C  ;  PTO ;  M9R786;  →C012567;  A/C  ;  A/C ;  PTO ; # OE 93161809 4431667  ;  A/C ;  PTO ; # OE 93198427 4434866 16x  12 mm 16x 1x 1x 1x	 529 0317 10  532 0534 10  534 0281 10  535 0080 10  FB 7PK1685  FB 7PK1741  FB 7PK1973  FB 7PK2000  538 0397 10  420 0086 10  422 0078 10  558 0059 10  559 0171 10  559 0171 30
	FAG	 →6V699999; 6Y999999;  right  right;  7V600001; 7Y000001→  →6V699999; 6Y999999;  left  left;  7V600001; 7Y000001→  ;  ABS ;  →3V613233  86 mm  ;  ABS ;  →3V613233  86 mm  ;  3V613234→  88 mm  68 mm   ↔   7V621198 7Y721613→;    right  left	 821 0490 10  821 0822 10  821 0489 10  821 0821 10  713 6441 20  713 6441 30  713 6442 90  713 6441 40  815 0068 30  818 0207 10  825 0260 10  825 0261 10  840 0274 10  840 0880 10  840 0879 10
08.06-	LUK	G6 ;  PK6.009 PK6.022 PK6.026 PK6.072 PK6.076 G6 ;  PK6.372 PK6.375 PK6.376  PK6.3##	GearBOX 462 0155 10 GearBOX 462 0203 10  624 3092 09  624 3092 33
		     ;  A/C   ;  A/C  # F-560843.XX F-556602.XX F-229643.XX  # F-234637.XX  ;  F4R 720 F4R 820;  A/C  ;  F4R 720 F4R 820;  A/C 16x  12 mm 16x	 530 0638 10  530 0638 30  531 0630 30  532 0654 10  529 0124 10  532 0364 20  534 0240 10  535 0030 10  535 0048 10  FB 5PK1125  FB 6PK1795  538 0392 10  420 0099 10  422 0009 10  821 0490 10  821 0822 10  821 0489 10
	FAG	 →6V699999; 6Y999999;  right  right; 7V600001; 7Y000001→ →6V699999; 6Y999999; left	 821 0490 10  821 0822 10  821 0489 10



			SCHAEFFLER
--	--	--	-------------------

OPEL

VIVARO A Box (F7)							
2.0 ECOTEC (F7) F4R 820; (86kW)	08.06-	FAG	 left;  7V600001; 7Y000001→  ; ABS ;  →3V613233  86 mm	 821 0821 10  713 6441 20			
			 ; ABS ;  →3V613233  86 mm	 713 6441 30			
			 ;  3V613234→  88 mm	 713 6442 90			
			 68 mm	 713 6441 40			
			 left	771 0507 30			
				 815 0068 30			
			 ↔	818 0207 10			
			 7V621198 7Y721613→; 	825 0261 10			
			 right	840 0274 10			
			 left	840 0880 10			
			 left	840 0879 10			
			2.0 16V (F7) F4R 720; (88kW)	08.01-	LUK	G6 ;  PK6.009 PK6.022 PK6.026 PK6.072 PK6.076 G6 ;  PK6.372 PK6.375 PK6.376	GearBOX 462 0155 10 GearBOX 462 0203 10
						 PK6  PK6.0##	 624 3092 09  624 3092 33  624 3092 34
							 530 0638 10
							 530 0638 30
	 531 0630 30						
	532 0654 10						
 ; +  ; →02.02; A/C	 529 0118 10						
 ; 02.02→; A/C	 529 0124 10						
 ; →02.02	 532 0243 10						
 ; 02.02→	 532 0364 20						
 ; A/C	 534 0142 30						
 ; A/C	 534 0240 10						
 # F-560843.XX F-556602.XX F-229643.XX	 535 0030 10						
 # F-234637.XX	 535 0048 10						
 ;  F4R 720 F4R 820; A/C	 FB 5PK1125						
 ;  F4R 720 F4R 820; A/C	 FB 6PK1795						
	538 0392 10						
 16x  12 mm	 420 0099 10						
 16x	 422 0009 10						
FAG	 →6V699999; 6Y999999;  right	 821 0490 10					
	 right;  7V600001; 7Y000001→	 821 0822 10					
	 →6V699999; 6Y999999;  left	 821 0489 10					
	 left;  7V600001; 7Y000001→	 821 0821 10					
	 ; ABS ;  →3V613233  86 mm	 713 6441 20					
	 ; ABS ;  →3V613233  86 mm	 713 6441 30					
	 ;  3V613234→  88 mm	 713 6442 90					
	 68 mm	 713 6441 40					
	 left	771 0507 30					
		 815 0068 30					
	 ↔	818 0207 10					
	 7V621198 7Y721613→; 	825 0260 10					
	 right	840 0274 10					
	 left	840 0880 10					
	 left	840 0879 10					
2.5 CDTI (F7) G9U 630; (84kW)	08.06-	RUVILLE	 →10.13	 755321			
			 →10.13;  PF6.0##	 624 3476 09  624 3476 34			
				 530 0198 10			
				 531 0548 10			
				 532 0313 20			
			 ; MY 2011; A/C ; OPTION	 529 0437 10			
			 ; MY 2011;  ; OPTION	 532 0333 10			
 ; A/C	 532 0364 20						
 ; MY 2011; A/C	 532 0364 20						



			SCHAEFFLER
--	---	--	-------------------

OPEL





































































VIVARO A Box (F7)

2.5 CDTI (F7)

 G9U 630; (84kW)

08.06-























































 ; MY 2011; A/C		532 0534 10
 ; A/C		534 0181 10
 ; -		
 ; A/C		534 0317 10
 ; -		
chassis # F-560843.XX F-556602.XX F-229643.XX		535 0030 10
chassis # F-238512.XX		535 0081 10
A/C		544 0098 10
 ; A/C		FB 7PK1113
 ; -		
 ; A/C		FB 7PK1795
 ; -		
 ; A/C ; OPTION		FB 7PK1835
 ; - ; OPTION		
		538 0374 10
16x		420 0063 10
 11 mm		
1x; 		428 0185 10
1x; 		428 0186 10
FAG  → 6V699999; 6Y999999;  right		821 0490 10
 right;  7V600001; 7Y000001 →		821 0822 10
 → 6V699999; 6Y999999;  left		821 0489 10
 left;  7V600001; 7Y000001 →		821 0821 10
 ; ABS ;  → 3V613233		713 6441 20
 86 mm		
 ; ABS ;  → 3V613233		713 6441 30
 86 mm		
 ;  3V613234 →		713 6442 90
 88 mm		
 68 mm		713 6441 40
		815 0068 30
 ↔		818 0207 10
		825 0260 10
 7V621198 7Y721613 → ; 		825 0261 10
		840 0274 10
 right		840 0880 10
 left		840 0879 10

2.5 DTI (F7)

 G9U 730; (99kW)

05.03-





































































































































G6 ;  PK6.007 PK6.027 PK6.028		GearBOX	462 0155 10
G6 ;  PK6.024 PK6.074 PK6.077		GearBOX	462 0202 10
 → C022528			623 3159 09
SAC			
 C022529 → ;  MANU			624 3945 09
01.06 → ;  C022529 → ;  MANU ;  PK6.3##			624 3945 33
→ 12.05 ;  C022529 → ;  MANU ;  PK6.0##			624 3945 34
→ 12.05 ;  C022529 → ;  SEMI ;  PA6.0## Easytronic			
 → 4V644188			415 0146 10
incl. 			
			530 0198 10
			531 0548 10
			532 0313 20
 ; A/C ; OPTION			529 0436 10
 ; - ; OPTION			
 ; A/C			532 0333 10
			532 0364 20
 ; A/C			534 0181 10
 ; -			
 ; A/C			534 0317 10
 ; -			
chassis # F-560843.XX F-556602.XX F-229643.XX			535 0030 10
A/C			544 0094 10
 ; A/C			FB 6PK1148
 ; -			
 ; A/C			FB 6PK1795
 ; -			
			538 0374 10
16x			420 0063 10
 11 mm			
1x; 			428 0185 10



			SCHAEFFLER
--	--	--	-------------------

OPEL

VIVARO A Box (F7)





2.5 DTI (F7) G9U 730; (99kW)	05.03-	 FAG	1x; 		428 0186 10	
			 →6V699999; 6Y999999;  right		821 0490 10	
			 right;  7V600001; 7Y000001→		821 0822 10	
			 →6V699999; 6Y999999;  left		821 0489 10	
			 left;  7V600001; 7Y000001→		821 0821 10	
			 ; ABS ;  →3V613233	 Set	713 6441 20	
			 86 mm			
			 ; ABS ;  →3V613233	 Set	713 6441 30	
			 86 mm			
			 ;  3V613234→	 Set	713 6442 90	
			 88 mm			
			 68 mm	 Set	713 6441 40	
					771 0507 30	
				 REP	815 0068 30	
			 ↔		818 0207 10	
					825 0260 10	
			 7V621198 7Y721613→; 		825 0261 10	
					840 0274 10	
		 right		840 0880 10		
		 left		840 0879 10		
		 SET	755321			
2.5 CDTI (F7) G9MB6; G9U 630; (107kW)	08.06-		 G9U 630; →10.13		624 3476 09	
			 G9U 630; →10.13;  PF6		624 3476 34	
						530 0198 10
						531 0548 10
						532 0313 20
						529 0437 10
			 ; MY 2011; A/C ; OPTION			532 0333 10
			 ; MY 2011; e ; OPTION			532 0364 20
			 ; A/C			532 0534 10
			 ; MY 2011; A/C			534 0181 10
			 ; A/C			534 0317 10
			 ; e			
			 ; A/C			535 0030 10
			 ; - e			535 0081 10
			 # F-560843.XX F-556602.XX F-229643.XX			544 0098 10
			 G9U 630			FB 7PK1113
			 # F-238512.XX			
			A/C			FB 7PK1795
			 ; A/C			FB 7PK1835
			 ; e			
			 ; A/C ; OPTION			538 0374 10
			 ; e ; OPTION			420 0063 10
			16x			
			 11 mm			
			1x; 		428 0185 10	
			1x; 		428 0186 10	
			FAG	 →6V699999; 6Y999999;  right		821 0490 10
				 right;  7V600001; 7Y000001→		821 0822 10
				 →6V699999; 6Y999999;  left		821 0489 10
				 left;  7V600001; 7Y000001→		821 0821 10
		 ; ABS ;  →3V613233		 Set	713 6441 20	
		 86 mm				
 ; ABS ;  →3V613233	 Set	713 6441 30				
 86 mm						
 ;  3V613234→	 Set	713 6442 90				
 88 mm						
 68 mm	 Set	713 6441 40				
	 REP	815 0068 30				
 ↔		818 0207 10				
		825 0260 10				
 7V621198 7Y721613→; 		825 0261 10				
		840 0274 10				































































































































			SCHAEFFLER
--	---	--	-------------------

OPEL

VIVARO A Box (F7)

2.5 CDTI (F7) G9MB6; G9U 630; (107kW)	08.06-	FAG	 right  left	 840 0880 10  840 0879 10
--	--------	------------	---	--

VIVARO A Platform/Chassis (X83)

1.9 Di F9Q 762; (60kW)	08.01-		G5 ;  PK5.011 PK5.013	GearBOX	462 0155 10	
			G5 ;  PK5.369	GearBOX	462 0203 10	
 →C039090			624 3087 09			
 →C039090; →05.05;  PK5 ;  № 0##			624 3087 33			
 →C039090; 06.05 →;  PK5 ;  № 3##			624 3087 34			
 C039091 →			624 3312 09			
 C039091 →; 06.05 →;  PK5 ;  № 3##			624 3312 33			
 C039091 →; →06.05;  PK5.3##			624 3312 34			
				530 0196 10		
				530 0196 30		
				533 0087 20		
 ; A/C				529 0124 10		
 ; A/C				529 0427 10		
 ; -e						
 ; A/C				532 0333 10		
			532 0364 20			
 # F-560843.XX F-556602.XX F-229643.XX			535 0030 10			
 # F-234637.XX			535 0048 10			
A/C			544 0089 10			
A/C			544 0101 10			
A/C			544 0101 20			
			538 0392 10			
FAG		 →6V699999; 6Y999999;  right		821 0490 10		
		 right;  7V600001; 7Y000001 →		821 0822 10		
		 →6V699999; 6Y999999;  left		821 0489 10		
		 left;  7V600001; 7Y000001 →		821 0821 10		
		 ; ABS ;  →3V613233		713 6441 20		
		 86 mm				
		 ; ABS ;  →3V613233		713 6441 30		
		 86 mm				
		 ;  3V613234 →		713 6442 90		
		 88 mm				
						
		 68 mm				
		 left				
						
		 ↔				
 7V621198 7Y721613 →; 						
						
 right						
 left						
1.9 DTI F9Q 760; (74kW)	08.06-		G6 ;  PK6.008 PK6.009 PK6.031 PK6.071 PK6.072 PK6.073 PK6.075 PK6.076 PK6.081 PK6.021 PK6.023 PK6.025	GearBOX	462 0155 10	
			G6 ;  PK6.371 PK6.373	GearBOX	462 0203 10	
			 →C092128		624 3087 09	
			 →C092128;  PK5 ;  № 3##		624 3087 34	
			 →C092128;  PK6 ;  № 3##			
			 →C092128;  PF6 ;  № 0##			
			 C092129 →		624 3312 09	
			 C092129 →;  PK5.3##		624 3312 34	
			 C092129 →;  PK6.3##			
			 C092129 →;  PF6.0##			
						530 0196 10
						530 0196 30
						533 0087 20
			 ; A/C			529 0124 10
			 ; A/C			529 0427 10
 ; -e						
 ; A/C			532 0333 10			
			532 0364 20			
 # F-560843.XX F-556602.XX F-229643.XX			535 0030 10			
 # F-234637.XX			535 0048 10			
A/C			544 0089 10			
A/C			544 0101 10			





OPEL

VIVARO A Platform/Chassis (X83)

1.9 DTI F9Q 760; (74kW)	08.06-		A/C		544 0101 20		
					538 0392 10		
			FAG	→6V699999; 6Y999999; right		821 0490 10	
				right; 7V600001; 7Y000001→		821 0822 10	
				→6V699999; 6Y999999; left		821 0489 10	
				left; 7V600001; 7Y000001→		821 0821 10	
				; ABS ; →3V613233		713 6441 20	
				86 mm			
				; ABS ; →3V613233		713 6441 30	
				86 mm			
				; 3V613234→		713 6442 90	
				88 mm			
				68 mm		713 6441 40	
				left		771 0507 30	
						814 0135 10	
				↔		818 0207 10	
						825 0260 10	
				7V621198 7Y721613→;		825 0261 10	
						840 0274 10	
				right		840 0880 10	
left		840 0879 10					
2.0 CDTI M9R 630; M9R 780; M9R 782; M9R 786; (66kW)	01.06-				624 3476 09		
			→02.14; PF6 ; № 0##		624 3476 34		
						532 0534 10	
						534 0281 10	
				# F-236675.XX F-561464.XX		535 0080 10	
				; PTO ; A/C		FB 7PK1741	
				; A/C ; PTO ; # OE 93161809 4431667		FB 7PK1973	
				; A/C ; PTO			
				; PTO ; A/C ; # OE 93198427 4434866		FB 7PK2000	
						538 0397 10	
				16x		420 0086 10	
				12 mm			
				16x		422 0078 10	
				1x		558 0059 10	
				1x		559 0171 10	
				1x		559 0171 30	
				FAG	→6V699999; 6Y999999; right		821 0490 10
					right; 7V600001; 7Y000001→		821 0822 10
					→6V699999; 6Y999999; left		821 0489 10
					left; 7V600001; 7Y000001→		821 0821 10
; ABS ; →3V613233		713 6441 20					
86 mm							
; ABS ; →3V613233		713 6441 30					
86 mm							
; 3V613234→		713 6442 90					
88 mm							
68 mm		713 6441 40					
		815 0068 30					
↔		818 0207 10					
		825 0260 10					
7V621198 7Y721613→;		825 0261 10					
		840 0274 10					
right		840 0880 10					
left		840 0879 10					
2.0 CDTI M9R 630; M9R 780; (84kW)	08.06-				624 3476 09		
			→02.14; PF6 ; № 0##		624 3476 34		
				; →07.14; M9R 692		529 0317 10	
				; →07.14; M9R 780			
				; →07.14; M9R 784			
				; →07.14; M9R 786			
				; →07.14; M9R 788			
						532 0534 10	
						534 0281 10	
				# F-236675.XX F-561464.XX		535 0080 10	
				; PTO ; A/C		FB 7PK1741	



			SCHAEFFLER
--	---	--	-------------------

OPEL

VIVARO A Platform/Chassis (X83)

2.0 CDTI
 M9R 630; M9R 780; (84kW)

08.06-



; A/C ; PTO ; # OE 93161809 4431667 ; A/C ; PTO		FB 7PK1973
; PTO ; A/C ; # OE 93198427 4434866		FB 7PK2000
16x 12 mm		538 0397 10 420 0086 10
16x		422 0078 10
1x		558 0059 10
1x		559 0171 10
1x		559 0171 30
FAG	→6V699999; 6Y999999; right	821 0490 10
right; →7V600001; 7Y000001→		821 0822 10
→6V699999; 6Y999999; left		821 0489 10
left; →7V600001; 7Y000001→		821 0821 10
; ABS ; →3V613233		713 6441 20
86 mm		713 6441 30
; ABS ; →3V613233		713 6441 30
86 mm		713 6442 90
; →3V613234→		713 6442 90
88 mm		713 6441 40
68 mm		713 6441 40
;		815 0068 30
↔		818 0207 10
;		825 0260 10
→7V621198 7Y721613→;		825 0261 10
;		840 0274 10
right		840 0880 10
left		840 0879 10

2.0 ECOTEC
 F4R 820; (86kW)

08.06-



G6 ; PK6.009 PK6.022 PK6.026 PK6.072 PK6.076	GearBOX	462 0155 10	
G6 ; PK6.372 PK6.375 PK6.376	GearBOX	462 0203 10	
; PK6 ; № 3##		624 3092 09	
	;		530 0638 10
;		530 0638 30	
;		531 0630 30	
; A/C		532 0654 10	
;		529 0124 10	
; A/C		532 0364 20	
; # F-560843.XX F-556602.XX F-229643.XX		534 0240 10	
; # F-234637.XX		535 0030 10	
; F4R 720 F4R 820; A/C		535 0048 10	
; F4R 720 F4R 820; A/C		FB 5PK1125	
;		FB 6PK1795	
;		538 0392 10	
16x 12 mm		420 0099 10	
16x		422 0009 10	



→6V699999; 6Y999999; right		821 0490 10
right; →7V600001; 7Y000001→		821 0822 10
→6V699999; 6Y999999; left		821 0489 10
left; →7V600001; 7Y000001→		821 0821 10
; ABS ; →3V613233		713 6441 20
86 mm		713 6441 30
; ABS ; →3V613233		713 6441 30
86 mm		713 6442 90
; →3V613234→		713 6442 90
88 mm		713 6441 40
68 mm		713 6441 40
; left		771 0507 30
;		815 0068 30
↔		818 0207 10
→7V621198 7Y721613→;		825 0261 10
;		840 0274 10
right		840 0880 10
left		840 0879 10

2.0 16V
 F4R 720; (88kW)

08.03-



































































G6 ; PK6.022 PK6.026	GearBOX	462 0155 10
G6 ; PK6.372 PK6.375 PK6.376	GearBOX	462 0203 10



			SCHAEFFLER
--	--	--	-------------------

OPEL

VIVARO A Platform/Chassis (X83)











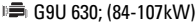























































































































2.0 16V F4R 720; (88kW)	08.03-		 PK6;  Nº 3##		624 3092 09
					624 3092 33
					530 0638 10
					530 0638 30
					531 0630 30
					532 0654 10
					529 0124 10
					532 0364 20
					534 0240 10
					535 0030 10
					535 0048 10
					FB 5PK1125
				FB 6PK1795	
				538 0392 10	
				420 0099 10	
				422 0009 10	
				821 0490 10	
				821 0822 10	
				821 0489 10	
				821 0821 10	
				Set 713 6441 20	
				Set 713 6441 30	
				Set 713 6442 90	
				Set 713 6441 40	
		771 0507 30			
		814 0135 10			
		818 0207 10			
		825 0260 10			
		825 0261 10			
		840 0274 10			
		840 0880 10			
		840 0879 10			
2.5 CDTI G9U 630; (84-107kW)	08.06-		→10.13		624 3476 09
			→10.13;  PF6;  Nº 0##		624 3476 34
					530 0198 10
					531 0548 10
					532 0313 20
					529 0437 10
					532 0333 10
					532 0364 20
					532 0534 10
					534 0181 10
					534 0317 10
					535 0030 10
				535 0081 10	
				544 0098 10	
				FB 7PK1113	
				FB 7PK1795	
				FB 7PK1835	
				538 0374 10	
				420 0063 10	
				428 0185 10	
				428 0186 10	
				821 0490 10	
				821 0822 10	
				821 0489 10	
		821 0821 10			
		821 0821 10			







			SCHAEFFLER
--	---	--	-------------------

OPEL

VIVARO A Platform/Chassis (X83)

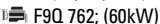
2.5 CDTI  G9U 630; (84-107kW)	08.06-	FAG	 ;  ;  →3V613233	 Set	713 6441 20
			 86 mm	 Set	713 6441 30
			 ;  ;  →3V613233	 Set	713 6442 90
			 86 mm	 Set	713 6441 40
			 ;  3V613234→	 Set	815 0068 30
			 88 mm	 Set	818 0207 10
			 68 mm	 REP	825 0260 10
			 ↔		825 0261 10
			 7V621198 7Y721613→; 		840 0274 10
					840 0880 10
			 right		840 0879 10
			 left		
			LUK G6 ;  PK6.007 PK6.027 PK6.028	GearBOX	462 0155 10
			G6 ;  PK6.024 PK6.074 PK6.077	GearBOX	462 0202 10
			 →C022528		623 3159 09
			SAC		
			 C022529→;  MANU		624 3945 09
01.06→;  C022529→;  MANU ;  PK6 ;  N° 3##		624 3945 33			
→12.05;  C022529→;  MANU ;  PK6 ;  N° 0##		624 3945 34			
→12.05;  C022529→;  SEMI ;  PA6 Easytronic ;  N° 0##					
 →4V644188		415 0146 10			
incl. 					
		530 0198 10			
		531 0548 10			
		532 0313 20			
 ; A/C ; OPTION		529 0436 10			
 ;  ; OPTION					
 ; A/C		532 0333 10			
		532 0364 20			
 ; A/C		534 0181 10			
					
 ; A/C		534 0317 10			
					
 # F-560843.XX F-556602.XX F-229643.XX		535 0030 10			
A/C		544 0094 10			
 ; A/C		FB 6PK1148			
					
 ; A/C		FB 6PK1795			
					
16x		538 0374 10			
 11 mm		420 0063 10			
1x; 		428 0185 10			
1x; 		428 0186 10			
FAG  →6V699999; 6Y999999;  right		821 0490 10			
 right;  7V600001; 7Y000001→		821 0822 10			
 →6V699999; 6Y999999;  left		821 0489 10			
 left;  7V600001; 7Y000001→		821 0821 10			
 ;  ;  →3V613233	 Set	713 6441 20			
 86 mm					
 ;  ;  →3V613233	 Set	713 6441 30			
 86 mm					
 ;  3V613234→	 Set	713 6442 90			
 88 mm					
 68 mm	 Set	713 6441 40			
		814 0135 10			
 ↔		818 0207 10			
 7V621198 7Y721613→; 		825 0261 10			
		840 0274 10			
 right		840 0880 10			
 left		840 0879 10			

VIVARO A Combi (X83)

1.9 DI (F7, J7, A07)  F9Q 762; (60kW)	08.01-	LUK	G5 G6 ;  PK5.011 PK5.013 PK6.021 PK6.023 PK6.025	GearBOX	462 0155 10
			G5 ; 	GearBOX	462 0203 10
			G6 ; 		











































			SCHAEFFLER
--	--	--	-------------------

OPEL

VIVARO A Combi (X83)

















1.9 DI (F7, J7, A07)
 F9Q 762; (60kW)

08.01-

	→C039090		624 3087 09
	→C039090; PK5.0##		624 3087 33
	→C039090; PK5.3##		624 3087 34
	C039091→		624 3312 09
	C039091→; PK5.0##		624 3312 33
	C039091→; PK5.3##		624 3312 34
			530 0196 10
			530 0196 30
			533 0087 20
	⊕; ⊙; A/C		529 0118 10
	⊕; 02.02→; A/C		529 0124 10
	⊕; A/C		529 0427 10
	⊕; ⊖		
	⊕; →02.02		532 0243 10
	⊕; A/C		532 0333 10
	⊕; 02.02→		532 0364 20
	⊕; A/C		534 0142 30
	⊕# F-560843.XX F-556602.XX F-229643.XX		535 0030 10
	⊕# F-234637.XX		535 0048 10
	A/C		544 0089 10
	A/C		544 0101 10
	A/C		544 0101 20
	⊕; A/C		FB 6PK1795
			538 0392 10
FAG	→6V699999; 6Y999999; right		821 0490 10
	right; 7V600001; 7Y000001→		821 0822 10
	→6V699999; 6Y999999; left		821 0489 10
	left; 7V600001; 7Y000001→		821 0821 10
	⊕; ABS; →3V613233		713 6441 20
	⊕ 86 mm		
	⊕; ABS; →3V613233		713 6441 30
	⊕ 86 mm		
	⊕; 3V613234→		713 6442 90
	⊕ 88 mm		
	⊕		713 6441 40
	⊕ 68 mm		
	⊕ left		771 0507 30
	⊕		815 0068 30
	⊕ ↔		818 0207 10
	⊕		825 0260 10
	7V621198 7Y721613→; ⊕		825 0261 10
	⊕		840 0274 10
	⊕ right		840 0880 10
	⊕ left		840 0879 10

1.9 DTI (F7, J7, A07)
 F9Q 760; (74kW)

08.01-

	G6; PK6.008 PK6.031 PK6.071 PK6.073 PK6.075 PK6.081		GearBOX	462 0155 10
	G6; PK6.371		GearBOX	462 0203 10
	→C092128			624 3087 09
	→05.05; →C092128; PK5.0##			624 3087 33
	→05.05; →C092128; PK6.0##			
	→05.05; →C092128; SEMI; Easytronic PA6.0##			
	06.05→; →C092128; PK5			624 3087 34
	06.05→; →C092128; PK6			
	06.05→; →C092128; PF6			
	→C092129→			624 3312 09
	→05.05; →C092129→; PK5.0##			624 3312 33
	→05.05; →C092129→; PK6.0##			
	→05.05; →C092129→; SEMI; Easytronic PA6.0##			
	06.05→; →C092129→; PK5.3##			624 3312 34
	06.05→; →C092129→; PK6.3##			
	06.05→; →C092129→; PF6.0##			
				530 0196 10
				530 0196 30
				533 0087 20
	⊕; ⊙; →02.02; A/C			529 0118 10
	⊕; 02.02→; A/C			529 0124 10
	⊕; A/C			529 0427 10
	⊕; ⊖			
	⊕; →02.02			532 0243 10



			SCHAEFFLER
--	---	--	-------------------





















OPEL

VIVARO A Combi (X83)





































1.9 DTI (F7, J7, A07)
 F9Q 760; (74kW)

08.01-









	A/C		532 0333 10
	02.02→		532 0364 20
	A/C		534 0142 30
	# F-560843.XX F-556602.XX F-229643.XX		535 0030 10
	# F-234637.XX		535 0048 10
	A/C		544 0089 10
	A/C		544 0101 10
	A/C		544 0101 20
	A/C		FB 6PK1795
	A/C		538 0392 10

FAG

	→6V699999; 6Y999999; right		821 0490 10
	right; 7V600001; 7Y000001→		821 0822 10
	→6V699999; 6Y999999; left		821 0489 10
	left; 7V600001; 7Y000001→		821 0821 10
	; ABS; →3V613233		713 6441 20
	86 mm		
	; ABS; →3V613233		713 6441 30
	86 mm		
	; 3V613234→		713 6442 90
	88 mm		
			713 6441 40
	68 mm		
	left		771 0507 30
			815 0068 30
	↔		818 0207 10
			825 0260 10
	7V621198 7Y721613→;		825 0261 10
			840 0274 10
	right		840 0880 10
	left		840 0879 10



































RUVILLE

			755321
			624 3476 09
	→02.14; PF6.0##		624 3476 34



			532 0534 10
			534 0281 10
	# F-236675.XX F-561464.XX		535 0080 10
	A/C; PTO; M9R786		FB 7PK1685
	PTO; A/C		FB 7PK1741
	PTO; A/C; M9R786; →C012567		FB 7PK1973
	A/C; PTO; # OE 93161809 4431667		FB 7PK2000
	A/C; PTO		FB 7PK2000
	PTO; A/C; # OE 93198427 4434866		538 0397 10
	16x		420 0086 10
	12 mm		
	16x		422 0078 10
	1x		558 0059 10
	1x		559 0171 10
	1x		559 0171 30

FAG

	→6V699999; 6Y999999; right		821 0490 10
	right; 7V600001; 7Y000001→		821 0822 10
	→6V699999; 6Y999999; left		821 0489 10
	left; 7V600001; 7Y000001→		821 0821 10
	; ABS; →3V613233		713 6441 20
	86 mm		
	; ABS; →3V613233		713 6441 30
	86 mm		
	; 3V613234→		713 6442 90
	88 mm		
			713 6441 40
	68 mm		
			815 0068 30
	↔		818 0207 10
			825 0260 10
	7V621198 7Y721613→;		825 0261 10
			840 0274 10
	right		840 0880 10
	left		840 0879 10

2.0 CDTI (F7, J7, A07)
 M9R 780; M9R 782; M9R 786;
 (66kW)

08.06-

































































			SCHAEFFLER
--	--	--	-------------------

OPEL

VIVARO A Combi (X83)







































2.0 CDTi (F7, J7, A07)
 M9R 630; M9R 692; M9R 780;
 M9R 784; M9R 786; M9R 788; (84kW)

08.06-

		→02.14; PF6.0##		624 3476 09	
				624 3476 34	
			 ; 07.14→; M9R 692		529 0317 10
			 ; 07.14→; M9R 780		
			 ; 07.14→; M9R 784		
			 ; 07.14→; M9R 786		
			 ; 07.14→; M9R 788		
				532 0534 10	
				534 0281 10	
		⊞# F-236675.XX F-561464.XX		535 0080 10	
		 ; A/C; PTO; M9R 786; C012568→; M9R 786		FB 7PK1685	
		 ; PTO; A/C		FB 7PK1741	
		 ; PTO; A/C; M9R 786; C012567→			
		 ; A/C; PTO; # OE 93161809 4431667		FB 7PK1973	
		 ; A/C; PTO			
		 ; PTO; A/C; # OE 93198427 4434866		FB 7PK2000	
		16x		538 0397 10	
		 12 mm		420 0086 10	
		16x		422 0078 10	
		1x		558 0059 10	
		1x		559 0171 10	
		1x		559 0171 30	
	FAG		 →6V699999; 6Y999999; right		821 0490 10
			 right; 7V600001; 7Y000001→		821 0822 10
			 →6V699999; 6Y999999; left		821 0489 10
			 left; 7V600001; 7Y000001→		821 0821 10
			 ; ABS; 3V613233		713 6441 20
			 86 mm		
		 ; ABS; 3V613233		713 6441 30	
		 86 mm			
		 ; 3V613234→		713 6442 90	
		 88 mm			
		 68 mm		713 6441 40	
				815 0068 30	
		 ↔		818 0207 10	
				825 0260 10	
		 7V621198 7Y721613→;		825 0261 10	
	 right		840 0274 10		
	 left		840 0880 10		
			840 0879 10		

2.0 ECOTEC (F7, A07, J7)
 F4R 820; (86kW)

08.06-

		G6; PK6.009 PK6.022 PK6.026 PK6.072 PK6.076	GearBOX	462 0155 10	
		G6; PK6.372 PK6.375 PK6.376	GearBOX	462 0203 10	
				624 3092 09	
		PK6.3##		624 3092 33	
					530 0638 10
					530 0638 30
					531 0630 30
					532 0654 10
			 ; A/C		529 0124 10
					532 0364 20
			 ; A/C		534 0240 10
			⊞# F-560843.XX F-556602.XX F-229643.XX		535 0030 10
			⊞# F-234637.XX		535 0048 10
			 ; F4R 720 F4R 820; A/C		FB 5PK1125
			 ; F4R 720 F4R 820; A/C		FB 6PK1795
					538 0392 10
			16x		420 0099 10
			 12 mm		
			16x		422 0009 10
	FAG		 →6V699999; 6Y999999; right		821 0490 10
			 right; 7V600001; 7Y000001→		821 0822 10
			 →6V699999; 6Y999999; left		821 0489 10
			 left; 7V600001; 7Y000001→		821 0821 10
			 ; ABS; 3V613233		713 6441 20
			 86 mm		
		 ; ABS; 3V613233		713 6441 30	
		 86 mm			



			<p>SCHAEFFLER</p>
--	--	--	--------------------------

OPEL

VIVARO A Combi (X83)

2.0 ECOTEC (F7, A07, J7)
 F4R 820; (86kW)

08.06-

FAG

🚗; 🚗 3V613234→
 🌀 88 mm

🌀 **Set**

713 6442 90

🌀 68 mm

🌀 **Set**

713 6441 40

🚗 left

🚗

771 0507 30

🚗

🌀 **REP**

815 0068 30

↔

↔

818 0207 10

🚗 7V621198 7Y721613→; 🚗

🌀

825 0261 10

🚗

🔑

840 0274 10

🚗 right

🚗

840 0880 10

🚗 left

🚗

840 0879 10

2.0 16V (F7, J7, A07)
 F4R 720; (88kW)

08.01-

LUK

G6; 🚗 PK6.009 PK6.022 PK6.026 PK6.031 PK6.071 PK6.072
 PK6.073 PK6.075 PK6.076 PK6.081

GearBOX

462 0155 10

G6; 🚗 PK6.372 PK6.375 PK6.376

GearBOX

462 0203 10

🌀

624 3092 09

10.05→; 🚗 PK6.3##

🌀

624 3092 33

→09.05; 🚗 PK6

🌀

624 3092 34

INA

🌀

🌀

530 0638 10

🌀

🌀

530 0638 30

🌀

🌀

531 0630 30

🌀

🌀

532 0654 10

🌀; + 🌀; →02.02; A/C

🌀

529 0118 10

🌀; 02.02→; A/C

🌀

529 0124 10

🌀; →02.02

🌀

532 0243 10

🌀; 02.02→

🌀

532 0364 20

🌀; A/C

🌀

534 0142 30

🌀; A/C

🌀

534 0240 10

🌀# F-560843.XX F-556602.XX F-229643.XX

🌀

535 0030 10

🌀# F-234637.XX

🌀

535 0048 10

🌀; 🚗 F4R 720 F4R 820; A/C

🌀

FB 5PK1125

🌀; 🚗 F4R 720 F4R 820; A/C

🌀

FB 6PK1795

🌀

538 0392 10

16x

🌀 12 mm

🌀

420 0099 10

16x

🌀

422 0009 10

FAG

🚗 →6V699999; 6Y999999; 🚗 right

🚗

821 0490 10

🚗 right; 🚗 7V600001; 7Y000001→

🚗

821 0822 10

🚗 →6V699999; 6Y999999; 🚗 left

🚗

821 0489 10

🚗 left; 🚗 7V600001; 7Y000001→

🚗

821 0821 10

🚗; ABS; 🚗 →3V613233

🌀

713 6441 20

🌀 86 mm

🚗; ABS; 🚗 →3V613233

🌀

713 6441 30

🌀 86 mm

🚗; 🚗 3V613234→

🌀

713 6442 90

🌀 88 mm

🌀 68 mm

🌀

713 6441 40

🚗 left

🚗

771 0507 30

🚗

🌀 **REP**

815 0068 30

↔

↔

818 0207 10

🚗

🌀

825 0260 10

🚗 7V621198 7Y721613→; 🚗

🌀

825 0261 10

🚗

🔑

840 0274 10

🚗 right

🚗

840 0880 10

🚗 left

🚗

840 0879 10

RUVILLE

🚗

🌀 **SET**

755321

2.5 CDTI (F7, J7, A07)
 G9U 630; (84-107kW)

08.06-

LUK

→10.13

🌀

624 3476 09

→10.13; 🚗 PF6.0##

🌀

624 3476 34

INA

🌀

🌀

530 0198 10

🌀

🌀

531 0548 10

🌀; MY 2011; A/C; **OPTION**

🌀

529 0437 10

🌀; MY 2011; 🌀; **OPTION**

🌀

532 0313 20

🌀; A/C

🌀

532 0333 10

🌀; MY 2011; A/C

🌀

532 0364 20

🌀; MY 2011; A/C

🌀

532 0534 10

🌀; A/C

🌀

534 0181 10

🌀; 🌀

































			SCHAEFFLER
--	--	--	-------------------

OPEL

VIVARO A Combi (X83)













2.5 CDTI (F7, J7, A07)
 G9U 630; (84-107kW)

08.06-

	 ; A/C  ; -e F-560843.XX F-556602.XX F-229643.XX F-238512.XX A/C  ; A/C  ; -e  ; A/C  ; e  ; A/C ; OPTION  ; e ; OPTION	                    	534 0317 10 535 0030 10 535 0081 10 544 0098 10 FB 7PK1113 FB 7PK1795 FB 7PK1835 538 0374 10 420 0063 10 428 0185 10 428 0186 10 821 0490 10 821 0822 10 821 0489 10 821 0821 10 Set 713 6441 20 Set 713 6441 30 Set 713 6442 90 Set 713 6441 40 REP 815 0068 30 818 0207 10 825 0260 10 825 0261 10 840 0274 10 840 0880 10 840 0879 10
	FAG	→6V699999; 6Y999999; right right; 7V600001; 7Y000001→ →6V699999; 6Y999999; left left; 7V600001; 7Y000001→ ; ABS; →3V613233 86 mm ; ABS; →3V613233 86 mm ; 3V613234→ 88 mm 68 mm ← 7V621198 7Y721613→;	821 0490 10 821 0822 10 821 0489 10 821 0821 10 Set 713 6441 20 Set 713 6441 30 Set 713 6442 90 Set 713 6441 40 REP 815 0068 30 818 0207 10 825 0260 10 825 0261 10 840 0274 10 840 0880 10 840 0879 10

2.5 DTI (F7, J7, A07)
 G9U 730; (99kW)

05.03-

	G6 ; PK6.007 PK6.027 PK6.028 G6 ; PK6.024 PK6.074 PK6.077 →C022528 SAC C022529→; MANU 01.06→; C022529→; MANU ; PK6 ; N° 3## →12.05; C022529→; MANU ; PK6 ; N° 0## →12.05; C022529→; SEMI ; PA6 Easytronic ; N° 0## →4V644188 incl.	GearBOX 462 0155 10 GearBOX 462 0202 10 623 3159 09 624 3945 09 624 3945 33 624 3945 34 415 0146 10		
		 ; A/C ; OPTION  ; e ; OPTION  ; A/C  ; A/C  ; e  ; A/C  ; e F-560843.XX F-556602.XX F-229643.XX A/C  ; A/C  ; -e  ; A/C  ; e 16x 11 mm 1x; 1x;	530 0198 10 531 0548 10 532 0313 20 529 0436 10 532 0333 10 532 0364 20 534 0181 10 534 0317 10 535 0030 10 544 0094 10 FB 6PK1148 FB 6PK1795 538 0374 10 420 0063 10 428 0185 10 428 0186 10	
		FAG	→6V699999; 6Y999999; right right; 7V600001; 7Y000001→	821 0490 10 821 0822 10

































			SCHAEFFLER
--	---	--	-------------------

OPEL

VIVARO A Combi (X83)

2.5 DTI (F7, J7, A07)
 G9U 730; (99kW)

05.03-	FAG	 →6V699999; 6Y999999;  left		821 0489 10
		 left;  7V600001; 7Y000001→		821 0821 10
		 ; ABS ;  →3V613233	 Set	713 6441 20
		 86 mm		
		 ; ABS ;  →3V613233	 Set	713 6441 30
		 86 mm		
		 ;  3V613234→	 Set	713 6442 90
		 88 mm		
		 68 mm	 Set	713 6441 40
				771 0507 30
			 REP	815 0068 30
		 ↔		818 0207 10
				825 0260 10
		 7V621198 7Y721613→; 		825 0261 10























 **RUVILLE**

 **SET**

755321

VIVARO B Combi (X82)

1.6 CDTI (06)
 R9M 408; (66kW)























06.14-	LUK	SAC		624 3930 33
		 ; A/C		415 0796 10
				529 0246 10
				532 0534 10
				534 0624 10
				535 0080 10
				535 0153 10
				538 0399 10
		16x		420 0086 10
		 12 mm		
		16x		422 0078 10
		FAG	 Set	713 6451 90
		 ↔		818 0207 10
				840 0274 10

FAG

Set

713 6451 90

1.6 CDTI (06)
 R9M 413; (70kW)























04.15-	LUK	SAC		624 3930 33
		 ; A/C		415 0796 10
				529 0246 10
				532 0534 10
				534 0624 10
				535 0080 10
				535 0153 10
				538 0399 10
		16x		420 0086 10
		 12 mm		
		16x		422 0078 10
		FAG	 Set	713 6451 90
		 ↔		818 0207 10
				840 0274 10

FAG

Set

713 6451 90

1.6 CDTI (06)
 R9M 408; R9M 450; (85kW)

06.14-	LUK	SAC		624 3930 33
		 ;  R9M 408; A/C		415 0796 10
		 ;  R9M 450; A/C		529 0247 10
				532 0534 10
				534 0624 10
				535 0080 10
				535 0153 10
				538 0399 10
		16x		420 0086 10
		 12 mm		
		16x		422 0078 10
		FAG	 Set	713 6451 90
		 ↔		818 0207 10

FAG

Set











































713 6451 90





























































			SCHAEFFLER
--	--	--	-------------------

OPEL

VIVARO B Combi (X82)

1.6 CDTI (06) R9M 408; R9M 450; (85kW)	06.14-	FAG	 840 0274 10	 840 0274 10						
			 right	 840 0880 10						
			 left	 840 0879 10						
		1.6 CDTI (06) R9M 450; (88-103kW)	06.14-	LUK	 SAC	 624 3930 33				
					 415 0796 10	 415 0796 10				
					 ; A/C	 529 0247 10				
				1.6 CDTI (06) R9M 452; (92-107kW)	04.15-	LUK	 532 0534 10	 532 0534 10		
							 534 0624 10	 534 0624 10		
							 # F-236675.XX F-561464.XX	 535 0080 10		
								INA	 # F-552305.XX	 535 0153 10
									 ; A/C	 FB 7PK1325
									 538 0399 10	 538 0399 10
								FAG	 16x	 420 0086 10
									 12 mm	 420 0086 10
									 16x	 422 0078 10
								FAG	 Set	 713 6451 90
									 ↔	 818 0207 10
									 right	 840 0274 10
								FAG	 left	 840 0880 10
									 right	 840 0879 10
									 left	 840 0879 10

VIVARO B Box (X82)





























































1.6 CDTI (05) R9M 408; (66kW)	06.14-	LUK	 SAC	 624 3930 33						
			 415 0796 10	 415 0796 10						
			 ; A/C	 529 0246 10						
		1.6 CDTI (05) R9M 413; (70kW)	08.16-	INA	 532 0534 10	 532 0534 10				
					 534 0624 10	 534 0624 10				
					 # F-236675.XX F-561464.XX	 535 0080 10				
						LUK	 # F-552305.XX	 535 0153 10		
							 538 0399 10	 538 0399 10		
							 16x	 420 0086 10		
								FAG	 12 mm	 420 0086 10
									 16x	 422 0078 10
									 Set	 713 6451 90
								FAG	 ↔	 818 0207 10
									 right	 840 0274 10
									 left	 840 0880 10
								LUK	 right	 840 0879 10
									 left	 840 0879 10
									 624 3930 33	 624 3930 33
								INA	 415 0796 10	 415 0796 10
									 ; A/C	 529 0246 10
									 532 0534 10	 532 0534 10
								LUK	 534 0624 10	 534 0624 10
									 # F-236675.XX F-561464.XX	 535 0080 10
									 # F-552305.XX	 535 0153 10
								FAG	 538 0399 10	 538 0399 10
									 16x	 420 0086 10
									 12 mm	 420 0086 10
								FAG	 16x	 422 0078 10
									 Set	 713 6451 90













			SCHAEFFLER
--	--	--	-------------------

OPEL

VIVARO B Box (X82)

1.6 CDTI (05) R9M 413; (70kW)	08.16-	FAG	 ↔		818 0207 10	
			 ↔		840 0274 10	
			 right		840 0880 10	
			 left		840 0879 10	
	1.6 CDTI (05) R9M 408; R9M 450; (85kW)	06.14-	LUK	SAC		624 3930 33
					415 0796 10	
					529 0246 10	
					529 0247 10	
				532 0534 10		
				534 0624 10		
				535 0080 10		
				535 0153 10		
			FB 7PK1325			
			538 0399 10			
			420 0086 10			
16x 12 mm						
16x				422 0078 10		
FAG					713 6451 90	
			↔		818 0207 10	
			↔		840 0274 10	
	right		840 0880 10			
left		840 0879 10				
1.6 CDTI (05) R9M 450; (88-103kW)	06.14-	LUK	SAC		624 3930 33	
				415 0796 10		
				529 0247 10		
				532 0534 10		
			534 0624 10			
			535 0080 10			
			535 0153 10			
			FB 7PK1325			
			538 0399 10			
			420 0086 10			
		16x 12 mm				
		16x		422 0078 10		
		FAG			713 6451 90	
			↔		818 0207 10	
			↔		840 0274 10	
			right		840 0880 10	
left		840 0879 10				
1.6 CDTI (05) R9M 452; (92-107kW)	03.16-	LUK	SAC		624 3930 33	
				415 0796 10		
				529 0247 10		
				532 0534 10		
			534 0624 10			
			535 0080 10			
			535 0153 10			
			FB 7PK1325			
			538 0399 10			
			420 0086 10			
		16x 12 mm				
		16x		422 0078 10		
		FAG			713 6451 90	
			↔		818 0207 10	
			↔		840 0274 10	
			right		840 0880 10	
left		840 0879 10				

VIVARO B Platform/Chassis (X82)











































































1.6 CDTI (03) R9M 408; R9M 450; (85kW)	06.14-	LUK	SAC		624 3930 33
				415 0796 10	
				529 0246 10	
				529 0247 10	
			532 0534 10		
			534 0624 10		
			535 0080 10		
			535 0153 10		
			FB 7PK1325		
					
					



			SCHAEFFLER
--	--	--	-------------------

































OPEL

VIVARO B Platform/Chassis (X82)

1.6 CDTI (03) R9M 408; R9M 450; (85kW)	06.14-		16x		538 0399 10			
			 12 mm		420 0086 10			
			16x		422 0078 10			
					713 6451 90			
			 ↔		818 0207 10			
					840 0274 10			
			 right		840 0880 10			
			 left		840 0879 10			
			1.6 CDTI (03) R9M 450; (88-103kW)	08.15-		SAC		624 3930 33
								415 0796 10
 ; A/C		529 0247 10						
		532 0534 10						
		534 0624 10						
♁# F-236675.XX F-561464.XX		535 0080 10						
♁# F-552305.XX		535 0153 10						
 ; A/C		FB 7PK1325						
		538 0399 10						
16x		420 0086 10						
 12 mm		422 0078 10						
16x		713 6451 90						
		818 0207 10						
 ↔		840 0274 10						
		840 0880 10						
 right		840 0879 10						
 left		840 0879 10						
1.6 CDTI (03) R9M 452; (92-107kW)	11.16-					SAC		624 3930 33
					415 0796 10			
			 ; A/C		529 0247 10			
					532 0534 10			
					534 0624 10			
			♁# F-236675.XX F-561464.XX		535 0080 10			
			♁# F-552305.XX		535 0153 10			
			 ; A/C		FB 7PK1325			
					538 0399 10			
			16x		420 0086 10			
			 12 mm		422 0078 10			
			16x		713 6451 90			
					818 0207 10			
			 ↔		840 0274 10			
			 ↔		840 0880 10			
			 right		840 0879 10			
			 left		840 0879 10			

PEUGEOT

Boxer I (230)











































































































































2.0 HDI RHV (DW10UTD); (62kW)	08.01-04.02		DW10TD; MLGU		623 3141 00
					530 0111 10
					530 0111 30
					531 0264 10
					532 0196 10
			 ; A/C		531 0373 10
					532 0335 10
			 ; A/C		534 0110 20
			 ; A/C		534 0111 20
			♁# F-232369/.02/.03 F-232369.09/.11		535 0179 10
			A/C		544 0039 10
			A/C		544 0039 20
					FB 4PK755
			 ; A/C		FB 6PK1183
			 ; A/C		FB 6PK1468
					538 0008 10
			1x		428 0034 30
					821 0810 10
			right; 16"		821 0859 10
			left; 16"		821 0809 10
			right; 15"		821 0858 10
			left; 15"		821 0858 10

































			SCHAEFFLER
--	--	--	-------------------

PEUGEOT

Boxer I (230)

2.0 HDI  RHV (DW10UTD); (62kW)	08.01-04.02		 ; 12.01 → ;  1.000 kg →  1.400 kg  84 mm	 Set	713 6403 90
			 ; 12.01 → ;  1.800kg  90 mm	 Set	713 6404 00
2.0  RFL (XU10J2U); (81kW)	12.01-04.02		 ; →11.01;  1.000 kg →  1.400 kg  80 mm	 Set	713 6503 10
			 ; →11.01;  1.800kg  89,92 mm	 Set	713 6503 30
			 ; 12.01 →  75 mm	 Set	713 6403 30
			 ; →11.01;  1.000 kg →  1.400 kg	 Set	713 6504 20
			 ; →11.01;  1.800kg	 Set	713 6504 30
			  → 1.400 kg  100 mm		771 0060 30
			  ;  1.000 kg →  1.400 kg  100 mm		771 0036 30
			  1.000 kg →  1.400 kg; 		772 0254 30
			 right;  →5616153		815 0058 30
			 left;  5616154 →		
			 left;  →5616153		815 0059 30
			 right;  5616154 →		
					818 0226 10
			 ;  15 "		825 0318 10
			 ;  16 "		825 0319 10
					840 0238 10
			 ; 		840 0285 10
			 ; 		840 0286 10
					840 0926 10
					FB 4PK755
			 ; A/C		FB 6PK1100
 8x  38 mm		421 0010 10			
			 right;  16 "		821 0810 10
			 right;  15 "		821 0859 10
			 left;  16 "		821 0809 10
			 left;  15 "		821 0858 10
			  → 1.400 kg  100 mm		771 0060 30
			  ;  1.000 kg →  1.400 kg  100 mm		771 0036 30
			  1.000 kg →  1.400 kg; 		772 0254 30
			 right;  →5616153		815 0058 30
			 left;  5616154 →		
			 left;  →5616153		815 0059 30
			 right;  5616154 →		
					818 0226 10
			 ;  15 "		825 0318 10
			 ;  16 "		825 0319 10
					840 0238 10
			 ; 		840 0285 10
			 ; 		840 0286 10
					840 0926 10

Boxer II (244)





























































2.0 HDi  RHV (DW10TD); RHV (DW10UTD); (62kW)	04.02-		 DW10TD;  MLGU		623 3141 00
					530 0111 10
					530 0111 30
					531 0264 10
					532 0196 10
			 ; →05.04		531 0373 10
			 ; A/C		532 0335 10
			 ; →05.04; A/C		
			 ; →05.04; A/C		534 0110 20
			 ; A/C		534 0111 20
			 ; 05.04 →; A/C		
			 # F-229603.XX		535 0039 10
			 # F-232369.04/.05/.07 F-232369.08		535 0059 10
			 # F-236591.01/.02/.04 F-236591.06		535 0062 10
			 # F-232369/02/03 F-232369.09/.11		535 0179 10



			SCHAEFFLER
--	--	--	-------------------

PEUGEOT

Boxer II (244)



















































































































2.0 HDi RHV (DW10TD); RHV (DW10UTD); (62kW)	04.02-		# F-236591.05/07	 535 0194 10
			→04.04; A/C	 544 0039 10
			→04.04; A/C	 544 0039 20
				 FB 4PK755
			A/C	 FB 6PK1183
			A/C; →05.04; A/C	 FB 6PK1468
			A/C; 05.04→; A/C	 FB 6PK875
				 538 0008 10
			1x	 428 0034 30
			FAG	right; 16"
		right; 15"		 821 0859 10
		left; 16"		 821 0809 10
		left; 15"		 821 0858 10
				 713 0400 20
		800 1.000 1.400kg; 84 mm		 Set 713 6403 90
		1.800kg; 90 mm		 Set 713 6404 00
		75 mm		 Set 713 6403 30
		→ 1.400 kg 100 mm		 771 0060 30
		1.800kg 122 mm		 771 0065 30
		→ 1.000 kg → 1.400 kg 100 mm		 771 0036 30
		1.000 kg → 1.400 kg; MANU		 SET 772 0254 30
		G5; 1.800kg		 SET 772 0327 30
		right		 814 0128 10
		left	 814 0127 10	
15"	 818 0226 10			
16"	 825 0318 10			
	 825 0319 10			
	 840 0238 10			
	 840 0285 10			
	 840 0286 10			
	 840 0999 10			
	 624 3401 00			
2.0 BiFuel (81kW)	12.01-06.06	LUK FAG	right; 16"	 821 0810 10
			right; 15"	 821 0859 10
			left; 16"	 821 0809 10
			left; 15"	 821 0858 10
			→ 1.400 kg 100 mm	 771 0060 30
			→ 1.000 kg → 1.400 kg 100 mm	 771 0036 30
			1.000 kg → 1.400 kg; MANU	 SET 772 0254 30
				 818 0226 10
			15"	 825 0318 10
			16"	 825 0319 10
				 840 0285 10
				 840 0286 10
				 840 0999 10
				 624 3401 00
2.0 RFL (XU10J2U); (81kW)	04.02-	LUK	MLGU	 530 0233 10
				 531 0047 10
			A/C	 531 0096 10
			A/C	 FB 4PK755
			 FB 6PK1100	
			 538 0468 10	
		8x 38 mm	 421 0010 10	
		1x	 OILP 553 0310 10	
		FAG	right; 16"	 821 0810 10
			right; 15"	 821 0859 10
			left; 16"	 821 0809 10
			left; 15"	 821 0858 10
				 713 0400 20



			<p>SCHAEFFLER</p>
--	---	--	--------------------------

PEUGEOT

Boxer II (244)











































































































































































<p>2.0 RFL (XU10J2U); (81kW)</p>	<p>04.02-</p>	<p>FAG</p>	<p>  800 1.000 1.400kg;   84 mm  1.800kg;   90 mm  75 mm  → 1.400 kg  100 mm  1.800kg  122 mm  MANU;  1.000 kg →  1.400 kg  100 mm  1.000 kg →  1.400 kg;  MANU  G5;  1.800kg  1.800kg right left   15 "  16 "     </p>	<p>  Set 713 6403 90  Set 713 6404 00  Set 713 6403 30  771 0060 30  771 0065 30  771 0036 30  SET 772 0254 30  SET 772 0327 30  SET 772 0327 30  814 0128 10  814 0127 10  818 0226 10  825 0318 10  825 0319 10  840 0238 10  840 0285 10  840 0286 10  840 0286 10  840 0999 10  625 3023 00 </p>
<p>2.2 HDi 4HY (DW12UTED); (74kW)</p>	<p>04.02-</p>	<p>LUK</p> <p></p> <p>FAG</p>	<p> →04.04 04.04→ →04.04 04.04→ →04.04 04.04→ →04.04 04.04→ 04.04→ 04.04→  ; →05.04  ; A/C  ; →05.04; A/C  ; →05.04; A/C  ; A/C  ; 05.04→; A/C  # F-229603.XX  # F-236591.01/.02/.04 F-236591.06  # F-232369/.02/.03 F-232369.09/.11  # F-236591.05/.07 A/C A/C   ; A/C  ; →05.04; A/C  ; 05.04→; A/C 1x  right;  16 "  right;  15 "  left;  16 "  left;  15 "   800 1.000 1.400kg;   84 mm  1.800kg;   90 mm  75 mm  → 1.400 kg  100 mm  1.800kg 122 mm MANU; 1.000 kg → 1.400 kg 100 mm </p>	<p>  530 0368 10  530 0447 10  530 0368 30  530 0447 30  531 0264 10  531 0769 10  532 0196 10  532 0460 10  531 0373 10  532 0335 10  534 0110 20  534 0111 20  535 0039 10  535 0062 10  535 0179 10  535 0194 10  544 0039 10  FB 4PK755  FB 6PK1183  FB 6PK1468  FB 6PK875  538 0428 10  428 0034 30  821 0810 10  821 0859 10  821 0809 10  821 0858 10  713 0400 20  Set 713 6403 90  Set 713 6404 00  Set 713 6403 30  771 0060 30  771 0065 30 771 0036 30 </p>



			SCHAEFFLER
--	--	--	-------------------

PEUGEOT

Boxer II (244)













































































































































































































2.2 HDi 4H1 (DW12UTED); (74kW)	04.02-	FAG 	 ;  1.000 kg →  1.400 kg;  MANU	 SET 772 0254 30
			 ;  1.800kg	 SET 772 0327 30
			 ;  G5;  1.800kg	 SET 772 0327 30
			 right	 814 0128 10
			 left	 814 0127 10
				 818 0226 10
			 ;  15 "	 825 0318 10
			 ;  16 "	 825 0319 10
				 840 0238 10
			 ; 	 840 0285 10
			 ; 	 840 0286 10
				 840 0999 10
			 MG5T	 624 3096 00
			 VF3#;  MLGU	 624 3165 00
			2.8 HDi 8140.43S (F28DTCR); (93kW)	09.05-09.09
 VF3#;  MLGU	 624 3165 00			
				
OPTION	 530 0117 10			
	 530 0601 10			
	 531 0557 10			
	 532 0239 20			
	 533 0114 10			
A/C;  →3980846	 531 0749 10			
A/C;  3980847→	 531 0812 10			
 ;  AUTOM	 532 0294 10			
A/C	 FB 5PK1100			
	 FB 6PK948			
 ;  AUTOM	 FB 6PK995			
	 428 0080 10			
FAG	 821 0810 10			
 right;  16 "	 821 0810 10			
 right;  15 "	 821 0859 10			
 left;  16 "	 821 0809 10			
 left;  15 "	 821 0858 10			
 ;  → 1.400 kg	 771 0060 30			
 100 mm				
 ;  MANU ;  1.000 kg →  1.400 kg	 771 0036 30			
 100 mm				
 ;  1.000 kg →  1.400 kg;  MANU	 SET 772 0254 30			
	 818 0226 10			
 ;  15 "	 825 0318 10			
 ;  16 "	 825 0319 10			
	 840 0238 10			
 ; 	 840 0285 10			
 ; 	 840 0286 10			
	 840 0999 10			
 MG5T	 624 3096 00			
 VF3#;  MLGU	 624 3165 00			
2.8 HDi 8140.43S (F28DTCR); (94kW)	04.02-	LUK 	 MG5T	 624 3096 00
			 VF3#;  MLGU	 624 3165 00
				
			OPTION	 530 0117 10
				 530 0601 10
				 531 0557 10
				 532 0239 20
				 533 0114 10
			A/C;  →3980846	 531 0749 10
			A/C;  3980847→	 531 0812 10
			 ;  AUTOM	 532 0294 10
			 # F-229603.XX	 535 0039 10
			A/C	 FB 5PK1100
				 FB 6PK948
			 ;  AUTOM	 FB 6PK995
	 538 0469 10			
	 428 0080 10			
FAG	 821 0810 10			
 right;  16 "	 821 0810 10			
 right;  15 "	 821 0859 10			
 left;  16 "	 821 0809 10			
 left;  15 "	 821 0858 10			
	 713 0400 20			
 800 1.000 1.400kg; 	 Set 713 6403 90			
 84 mm				
 1.800kg; 	 Set 713 6404 00			
 90 mm				
 75 mm	 Set 713 6403 30			



			SCHAEFFLER
--	---	--	-------------------

PEUGEOT

Boxer II (244)







































































<p>2.8 HDi 8140.43S (F28DTCR); (94kW)</p>	<p>04.02-</p>	<p>FAG</p> <ul style="list-style-type: none">  → 1.400 kg  100 mm  1.800kg  122 mm  MANU ; 1.000 kg → 1.400 kg  100 mm  1.000 kg → 1.400 kg ; MANU  G5 ; 1.800kg  1.800kg right left   15 "  16 "     	<ul style="list-style-type: none">  771 0060 30  771 0065 30  771 0036 30  SET 772 0254 30  SET 772 0327 30  SET 772 0327 30  814 0128 10  814 0127 10  818 0226 10  825 0318 10  825 0319 10  840 0238 10  840 0285 10  840 0286 10  840 0999 10  624 3096 00  624 3165 00  530 0117 10  530 0601 10  531 0557 10  532 0239 20  533 0114 10  531 0749 10  531 0812 10  532 0294 10  535 0039 10  FB 5PK1100  FB 6PK948  FB 6PK995  538 0469 10  428 0080 10  821 0810 10  821 0859 10  821 0809 10  821 0858 10  713 0400 20  Set 713 6403 90  Set 713 6404 00  Set 713 6909 60  771 0060 30  771 0065 30  771 0036 30  SET 772 0254 30  SET 772 0327 30  814 0128 10  814 0127 10  818 0226 10  825 0318 10  825 0319 10  840 0238 10  840 0285 10  840 0286 10  840 0999 10  624 3165 00  530 0117 10  530 0601 10  531 0557 10  532 0239 20  533 0114 10  531 0749 10
<p>2.8 HDi 4x4 8140.43S (F28DTCR); (94kW)</p>	<p>04.02-</p>	<p>LUK</p> <ul style="list-style-type: none"> MG5T VF3#; MLGU <p>INA</p> <p>OPTION</p> <ul style="list-style-type: none">                                            <p>FAG</p> <ul style="list-style-type: none"> right; 16 " right; 15 " left; 16 " left; 15 "  800 1.000 1.400kg;  84 mm 1.800kg;  90 mm  84 mm  → 1.400 kg 100 mm  1.800kg 122 mm  MANU ; 1.000 kg → 1.400 kg 100 mm  1.000 kg → 1.400 kg ; MANU  G5 ; 1.800kg right left   15 "  16 "                	<ul style="list-style-type: none">  624 3096 00  624 3165 00  530 0117 10  530 0601 10  531 0557 10  532 0239 20  533 0114 10  531 0749 10  531 0812 10  532 0294 10  535 0039 10  FB 5PK1100  FB 6PK948  FB 6PK995  538 0469 10  428 0080 10  821 0810 10  821 0859 10  821 0809 10  821 0858 10  713 0400 20  Set 713 6403 90  Set 713 6404 00  Set 713 6909 60  771 0060 30  771 0065 30  771 0036 30  SET 772 0254 30  SET 772 0327 30  814 0128 10  814 0127 10  818 0226 10  825 0318 10  825 0319 10  840 0238 10  840 0285 10  840 0286 10  840 0999 10  624 3165 00  530 0117 10  530 0601 10  531 0557 10  532 0239 20  533 0114 10  531 0749 10
<p>2.8 HDi 8140.43N; (107kW)</p>	<p>04.04-</p>	<p>LUK</p> <ul style="list-style-type: none"> MLGU <p>INA</p> <p>OPTION</p> <ul style="list-style-type: none">      <p>A/C ;  →3980846</p>	<ul style="list-style-type: none">  624 3165 00  530 0117 10  530 0601 10  531 0557 10  532 0239 20  533 0114 10  531 0749 10

























































			SCHAEFFLER
--	--	--	-------------------

PEUGEOT

Boxer II (244)

2.8 HDi 8140.43N; (107kW)	04.04-		A/C;  3980847→		531 0812 10	
			 ;  AUTOM		532 0294 10	
			 # F-229603.XX		535 0039 10	
			A/C		FB 5PK1100	
		 ;  AUTOM		FB 6PK948		
				FB 6PK995		
				538 0469 10		
				428 0080 10		
		FAG	 right;  16 "		821 0810 10	
					 right;  15 "	821 0859 10
					 left;  16 "	821 0809 10
					 left;  15 "	821 0858 10
						713 0400 20
					 800 1.000 1.400kg; 	 713 6403 90
					 84 mm	
					 1.800kg; 	 713 6404 00
					 90 mm	
						 713 6403 30
					  → 1.400 kg	 771 0060 30
					 100 mm	
					  ;  MANU ;  1.000 kg →  1.400 kg	 771 0036 30
					 100 mm	
					  1.000 kg →  1.400 kg;  MANU	 772 0254 30
					 right	 814 0128 10
 left	 814 0127 10					
	 818 0226 10					
 ;  15 "	 825 0318 10					
 ;  16 "	 825 0319 10					
	 840 0238 10					
	 840 0285 10					
	 840 0286 10					
	 840 0999 10					

















































































































































































































































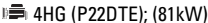

























































































































































Boxer III

2.0 BlueHDi 110 2.0 BlueHDi 130 2.0 BlueHDi 160 AHM (DW10FUE); AHN (DW10FUD); AHP (DW10FUC); (81-120kW)	07.15-09.19		SAC		626 3075 00	
					530 0691 10	
					530 0691 30	
					531 0885 10	
				532 0473 10		
				529 0310 10		
				535 0317 10		
				544 0097 10		
				544 0097 20		
				538 0077 10		
				420 0234 10		
				422 0107 10		
				559 0106 10		
		FAG	 right		821 0628 10	
					 left	821 0627 10
						 713 6405 50
					 90 mm	
					 ;  1.600 2.000kg; 	 713 6405 60
					 ;  1.200 1.400 1.600kg; 	 713 6405 70
						 814 0157 10
	 814 0158 10					
	 818 0012 10					
	 818 0479 10					
	 818 0473 10					
 ↔ ;  ; OPTION	 818 0480 10					
	 825 0277 10					
	 840 0388 10					
 right	 840 1050 10					
 left	 840 1055 10					
2.0 BlueHDi 160 (118kW)	04.17-09.19		SAC		626 3075 00	
					535 0317 10	
			 # F-602952.XX			



			SCHAEFFLER
--	--	--	-------------------



























































































































PEUGEOT

Boxer III																																																																																																
2.0 BlueHDi 160 	04.17-09.19	 FAG	<table style="width: 100%; border-collapse: collapse;"> <tr> <td style="width: 80%; padding: 2px;">16x;  DW10F</td> <td style="width: 20%; text-align: center; padding: 2px;"></td> <td style="width: 10%; text-align: center; padding: 2px;">420 0234 10</td> </tr> <tr> <td style="padding: 2px;"> 12 mm</td> <td style="padding: 2px;"></td> <td style="text-align: center; padding: 2px;">422 0107 10</td> </tr> <tr> <td style="padding: 2px;">16x;  DW10F</td> <td style="padding: 2px;"></td> <td style="text-align: center; padding: 2px;">713 6405 50</td> </tr> <tr> <td style="padding: 2px;"> 90 mm</td> <td style="padding: 2px;"></td> <td style="text-align: center; padding: 2px;">713 6405 60</td> </tr> <tr> <td style="padding: 2px;"> 1.600 2.000kg; </td> <td style="padding: 2px;"></td> <td style="text-align: center; padding: 2px;">713 6405 70</td> </tr> <tr> <td style="padding: 2px;"> 1.200 1.400 1.600kg; </td> <td style="padding: 2px;"></td> <td style="text-align: center; padding: 2px;">713 6405 70</td> </tr> </table>	16x;  DW10F		420 0234 10	 12 mm		422 0107 10	16x;  DW10F		713 6405 50	 90 mm		713 6405 60	 1.600 2.000kg; 		713 6405 70	 1.200 1.400 1.600kg; 		713 6405 70																																																																											
16x;  DW10F		420 0234 10																																																																																														
 12 mm		422 0107 10																																																																																														
16x;  DW10F		713 6405 50																																																																																														
 90 mm		713 6405 60																																																																																														
 1.600 2.000kg; 		713 6405 70																																																																																														
 1.200 1.400 1.600kg; 		713 6405 70																																																																																														
2.2 HDi 100 	04.06-	  FAG	<table style="width: 100%; border-collapse: collapse;"> <tr> <td style="width: 80%; padding: 2px;">SAC</td> <td style="width: 20%; text-align: center; padding: 2px;"></td> <td style="width: 10%; text-align: center; padding: 2px;">624 3303 00</td> </tr> <tr> <td style="padding: 2px;"> ; A/C für Fahrzeuge mit hydraulischer Servolenkung</td> <td style="padding: 2px;"></td> <td style="text-align: center; padding: 2px;">529 0301 10</td> </tr> <tr> <td style="padding: 2px;"> ; A/C für Fahrzeuge mit hydraulischer Servolenkung</td> <td style="padding: 2px;"></td> <td style="text-align: center; padding: 2px;">529 0301 30</td> </tr> <tr> <td style="padding: 2px;"> ; A/C</td> <td style="padding: 2px;"></td> <td style="text-align: center; padding: 2px;">532 0470 10</td> </tr> <tr> <td style="padding: 2px;"> ; A/C</td> <td style="padding: 2px;"></td> <td style="text-align: center; padding: 2px;">532 0477 10</td> </tr> <tr> <td style="padding: 2px;"> ; A/C</td> <td style="padding: 2px;"></td> <td style="text-align: center; padding: 2px;">534 0308 10</td> </tr> <tr> <td style="padding: 2px;"># F-554766.XX</td> <td style="padding: 2px;"></td> <td style="text-align: center; padding: 2px;">535 0160 10</td> </tr> <tr> <td style="padding: 2px;"></td> <td style="padding: 2px;"></td> <td style="text-align: center; padding: 2px;">FB 4EPK922</td> </tr> <tr> <td style="padding: 2px;"> ; A/C</td> <td style="padding: 2px;"></td> <td style="text-align: center; padding: 2px;">FB 6EPK873</td> </tr> <tr> <td style="padding: 2px;"> ; A/C</td> <td style="padding: 2px;"></td> <td style="text-align: center; padding: 2px;">FB 6PK1670</td> </tr> <tr> <td style="padding: 2px;"></td> <td style="padding: 2px;"></td> <td style="text-align: center; padding: 2px;">538 0465 10</td> </tr> <tr> <td style="padding: 2px;">1x</td> <td style="padding: 2px;"></td> <td style="text-align: center; padding: 2px;">558 0063 10</td> </tr> <tr> <td style="padding: 2px;">1x</td> <td style="padding: 2px;"></td> <td style="text-align: center; padding: 2px;">558 0066 10</td> </tr> <tr> <td style="padding: 2px;">1x</td> <td style="padding: 2px;"></td> <td style="text-align: center; padding: 2px;">559 0193 10</td> </tr> <tr> <td style="padding: 2px;">1x</td> <td style="padding: 2px;"></td> <td style="text-align: center; padding: 2px;">559 0193 30</td> </tr> <tr> <td style="padding: 2px;"> right</td> <td style="padding: 2px;"></td> <td style="text-align: center; padding: 2px;">821 0628 10</td> </tr> <tr> <td style="padding: 2px;"> left</td> <td style="padding: 2px;"></td> <td style="text-align: center; padding: 2px;">821 0627 10</td> </tr> <tr> <td style="padding: 2px;"> 90 mm</td> <td style="padding: 2px;"></td> <td style="text-align: center; padding: 2px;">713 6405 50</td> </tr> <tr> <td style="padding: 2px;"> 1.600 2.000kg; </td> <td style="padding: 2px;"></td> <td style="text-align: center; padding: 2px;">713 6405 60</td> </tr> <tr> <td style="padding: 2px;"> 1.200 1.400 1.600kg; </td> <td style="padding: 2px;"></td> <td style="text-align: center; padding: 2px;">713 6405 70</td> </tr> <tr> <td style="padding: 2px;"> ; </td> <td style="padding: 2px;"></td> <td style="text-align: center; padding: 2px;">771 0573 30</td> </tr> <tr> <td style="padding: 2px;"> ; </td> <td style="padding: 2px;"></td> <td style="text-align: center; padding: 2px;">814 0157 10</td> </tr> <tr> <td style="padding: 2px;"> ; </td> <td style="padding: 2px;"></td> <td style="text-align: center; padding: 2px;">814 0158 10</td> </tr> <tr> <td style="padding: 2px;"></td> <td style="padding: 2px;"></td> <td style="text-align: center; padding: 2px;">818 0012 10</td> </tr> <tr> <td style="padding: 2px;"></td> <td style="padding: 2px;"></td> <td style="text-align: center; padding: 2px;">818 0479 10</td> </tr> <tr> <td style="padding: 2px;"></td> <td style="padding: 2px;"></td> <td style="text-align: center; padding: 2px;">818 0473 10</td> </tr> <tr> <td style="padding: 2px;"> ;  ; OPTION</td> <td style="padding: 2px;"></td> <td style="text-align: center; padding: 2px;">818 0480 10</td> </tr> <tr> <td style="padding: 2px;"></td> <td style="padding: 2px;"></td> <td style="text-align: center; padding: 2px;">825 0277 10</td> </tr> <tr> <td style="padding: 2px;"></td> <td style="padding: 2px;"></td> <td style="text-align: center; padding: 2px;">840 0388 10</td> </tr> <tr> <td style="padding: 2px;"> right</td> <td style="padding: 2px;"></td> <td style="text-align: center; padding: 2px;">840 1050 10</td> </tr> <tr> <td style="padding: 2px;"> left</td> <td style="padding: 2px;"></td> <td style="text-align: center; padding: 2px;">840 1055 10</td> </tr> </table>	SAC		624 3303 00	 ; A/C für Fahrzeuge mit hydraulischer Servolenkung		529 0301 10	 ; A/C für Fahrzeuge mit hydraulischer Servolenkung		529 0301 30	 ; A/C		532 0470 10	 ; A/C		532 0477 10	 ; A/C		534 0308 10	# F-554766.XX		535 0160 10			FB 4EPK922	 ; A/C		FB 6EPK873	 ; A/C		FB 6PK1670			538 0465 10	1x		558 0063 10	1x		558 0066 10	1x		559 0193 10	1x		559 0193 30	 right		821 0628 10	 left		821 0627 10	 90 mm		713 6405 50	 1.600 2.000kg; 		713 6405 60	 1.200 1.400 1.600kg; 		713 6405 70	 ; 		771 0573 30	 ; 		814 0157 10	 ; 		814 0158 10			818 0012 10			818 0479 10			818 0473 10	 ;  ; OPTION		818 0480 10			825 0277 10			840 0388 10	 right		840 1050 10	 left		840 1055 10
SAC		624 3303 00																																																																																														
 ; A/C für Fahrzeuge mit hydraulischer Servolenkung		529 0301 10																																																																																														
 ; A/C für Fahrzeuge mit hydraulischer Servolenkung		529 0301 30																																																																																														
 ; A/C		532 0470 10																																																																																														
 ; A/C		532 0477 10																																																																																														
 ; A/C		534 0308 10																																																																																														
# F-554766.XX		535 0160 10																																																																																														
		FB 4EPK922																																																																																														
 ; A/C		FB 6EPK873																																																																																														
 ; A/C		FB 6PK1670																																																																																														
		538 0465 10																																																																																														
1x		558 0063 10																																																																																														
1x		558 0066 10																																																																																														
1x		559 0193 10																																																																																														
1x		559 0193 30																																																																																														
 right		821 0628 10																																																																																														
 left		821 0627 10																																																																																														
 90 mm		713 6405 50																																																																																														
 1.600 2.000kg; 		713 6405 60																																																																																														
 1.200 1.400 1.600kg; 		713 6405 70																																																																																														
 ; 		771 0573 30																																																																																														
 ; 		814 0157 10																																																																																														
 ; 		814 0158 10																																																																																														
		818 0012 10																																																																																														
		818 0479 10																																																																																														
		818 0473 10																																																																																														
 ;  ; OPTION		818 0480 10																																																																																														
		825 0277 10																																																																																														
		840 0388 10																																																																																														
 right		840 1050 10																																																																																														
 left		840 1055 10																																																																																														
2.2 HDi 110 	03.11-	  FAG	<table style="width: 100%; border-collapse: collapse;"> <tr> <td style="width: 80%; padding: 2px;">SAC</td> <td style="width: 20%; text-align: center; padding: 2px;"></td> <td style="width: 10%; text-align: center; padding: 2px;">624 3303 00</td> </tr> <tr> <td style="padding: 2px;"> ; A/C für Fahrzeuge mit hydraulischer Servolenkung</td> <td style="padding: 2px;"></td> <td style="text-align: center; padding: 2px;">529 0301 10</td> </tr> <tr> <td style="padding: 2px;"> ; A/C für Fahrzeuge mit hydraulischer Servolenkung</td> <td style="padding: 2px;"></td> <td style="text-align: center; padding: 2px;">529 0301 30</td> </tr> <tr> <td style="padding: 2px;"> ; A/C</td> <td style="padding: 2px;"></td> <td style="text-align: center; padding: 2px;">532 0470 10</td> </tr> <tr> <td style="padding: 2px;"> ; A/C</td> <td style="padding: 2px;"></td> <td style="text-align: center; padding: 2px;">532 0477 10</td> </tr> <tr> <td style="padding: 2px;"> ; A/C</td> <td style="padding: 2px;"></td> <td style="text-align: center; padding: 2px;">534 0308 10</td> </tr> <tr> <td style="padding: 2px;"># F-554766.XX</td> <td style="padding: 2px;"></td> <td style="text-align: center; padding: 2px;">535 0160 10</td> </tr> <tr> <td style="padding: 2px;"> DW12RU*</td> <td style="padding: 2px;"></td> <td style="text-align: center; padding: 2px;">535 0317 10</td> </tr> <tr> <td style="padding: 2px;"># F-602952.XX</td> <td style="padding: 2px;"></td> <td style="text-align: center; padding: 2px;"></td> </tr> <tr> <td style="padding: 2px;"></td> <td style="padding: 2px;"></td> <td style="text-align: center; padding: 2px;">FB 4EPK922</td> </tr> <tr> <td style="padding: 2px;"> ; A/C</td> <td style="padding: 2px;"></td> <td style="text-align: center; padding: 2px;">FB 6EPK873</td> </tr> <tr> <td style="padding: 2px;"> ; A/C</td> <td style="padding: 2px;"></td> <td style="text-align: center; padding: 2px;">FB 6PK1670</td> </tr> <tr> <td style="padding: 2px;"> 22DT</td> <td style="padding: 2px;"></td> <td style="text-align: center; padding: 2px;">538 0465 10</td> </tr> <tr> <td style="padding: 2px;"> right</td> <td style="padding: 2px;"></td> <td style="text-align: center; padding: 2px;">821 0628 10</td> </tr> <tr> <td style="padding: 2px;"> left</td> <td style="padding: 2px;"></td> <td style="text-align: center; padding: 2px;">821 0627 10</td> </tr> <tr> <td style="padding: 2px;"> 90 mm</td> <td style="padding: 2px;"></td> <td style="text-align: center; padding: 2px;">713 6405 50</td> </tr> <tr> <td style="padding: 2px;"> 1.600 2.000kg; </td> <td style="padding: 2px;"></td> <td style="text-align: center; padding: 2px;">713 6405 60</td> </tr> <tr> <td style="padding: 2px;"> 1.200 1.400 1.600kg; </td> <td style="padding: 2px;"></td> <td style="text-align: center; padding: 2px;">713 6405 70</td> </tr> <tr> <td style="padding: 2px;"> ; </td> <td style="padding: 2px;"></td> <td style="text-align: center; padding: 2px;">814 0157 10</td> </tr> <tr> <td style="padding: 2px;"> ; </td> <td style="padding: 2px;"></td> <td style="text-align: center; padding: 2px;">814 0158 10</td> </tr> <tr> <td style="padding: 2px;"></td> <td style="padding: 2px;"></td> <td style="text-align: center; padding: 2px;">818 0012 10</td> </tr> <tr> <td style="padding: 2px;"></td> <td style="padding: 2px;"></td> <td style="text-align: center; padding: 2px;">818 0479 10</td> </tr> <tr> <td style="padding: 2px;"></td> <td style="padding: 2px;"></td> <td style="text-align: center; padding: 2px;">818 0473 10</td> </tr> <tr> <td style="padding: 2px;"> ;  ; OPTION</td> <td style="padding: 2px;"></td> <td style="text-align: center; padding: 2px;">818 0480 10</td> </tr> <tr> <td style="padding: 2px;"></td> <td style="padding: 2px;"></td> <td style="text-align: center; padding: 2px;">825 0277 10</td> </tr> <tr> <td style="padding: 2px;"></td> <td style="padding: 2px;"></td> <td style="text-align: center; padding: 2px;">840 0388 10</td> </tr> </table>	SAC		624 3303 00	 ; A/C für Fahrzeuge mit hydraulischer Servolenkung		529 0301 10	 ; A/C für Fahrzeuge mit hydraulischer Servolenkung		529 0301 30	 ; A/C		532 0470 10	 ; A/C		532 0477 10	 ; A/C		534 0308 10	# F-554766.XX		535 0160 10	 DW12RU*		535 0317 10	# F-602952.XX					FB 4EPK922	 ; A/C		FB 6EPK873	 ; A/C		FB 6PK1670	 22DT		538 0465 10	 right		821 0628 10	 left		821 0627 10	 90 mm		713 6405 50	 1.600 2.000kg; 		713 6405 60	 1.200 1.400 1.600kg; 		713 6405 70	 ; 		814 0157 10	 ; 		814 0158 10			818 0012 10			818 0479 10			818 0473 10	 ;  ; OPTION		818 0480 10			825 0277 10			840 0388 10															
SAC		624 3303 00																																																																																														
 ; A/C für Fahrzeuge mit hydraulischer Servolenkung		529 0301 10																																																																																														
 ; A/C für Fahrzeuge mit hydraulischer Servolenkung		529 0301 30																																																																																														
 ; A/C		532 0470 10																																																																																														
 ; A/C		532 0477 10																																																																																														
 ; A/C		534 0308 10																																																																																														
# F-554766.XX		535 0160 10																																																																																														
 DW12RU*		535 0317 10																																																																																														
# F-602952.XX																																																																																																
		FB 4EPK922																																																																																														
 ; A/C		FB 6EPK873																																																																																														
 ; A/C		FB 6PK1670																																																																																														
 22DT		538 0465 10																																																																																														
 right		821 0628 10																																																																																														
 left		821 0627 10																																																																																														
 90 mm		713 6405 50																																																																																														
 1.600 2.000kg; 		713 6405 60																																																																																														
 1.200 1.400 1.600kg; 		713 6405 70																																																																																														
 ; 		814 0157 10																																																																																														
 ; 		814 0158 10																																																																																														
		818 0012 10																																																																																														
		818 0479 10																																																																																														
		818 0473 10																																																																																														
 ;  ; OPTION		818 0480 10																																																																																														
		825 0277 10																																																																																														
		840 0388 10																																																																																														



			SCHAEFFLER
--	--	--	-------------------

PEUGEOT

Boxer III							
2.2 HDi 110 4HG (P22DTE); (81kW)	03.11-	FAG	 right		840 1050 10		
			 left		840 1055 10		
2.2 HDi 120 4HU (P22DTE); (88kW)	04.06-	LUK	→12.10;  PUMA 22DT;  MLGUC14		600 0318 00		
			incl.  ; incl. 		600 0318 00		
			→12.10; 		600 0318 00		
			incl.  ; incl. 		600 0318 00		
			 PUMA 22DT; →12.10;  MLGUC14		626 3032 00		
			SAC		626 3032 00		
			→12.10; 		626 3032 00		
			SAC		626 3032 00		
			 PUMA 22DT; 01.11→;  MLGUC14		626 3075 00		
			SAC		626 3075 00		
			01.11→; 		626 3075 00		
			SAC		626 3075 00		
			 PUMA 22DT; →12.10		415 0372 10		
			→12.10		415 0372 10		
				411 0120 10			
				411 0120 10			
		  ; A/C für Fahrzeuge mit hydraulischer Servolenkung		529 0301 10			
		 ; A/C für Fahrzeuge mit hydraulischer Servolenkung		529 0301 30			
		 ; A/C		532 0470 10			
		 ; A/C		532 0477 10			
		 ; A/C		534 0308 10			
		# F-554766.XX		535 0160 10			
				FB 4EPK922			
		 ; A/C		FB 6EPK873			
		 ; A/C		FB 6PK1670			
				538 0465 10			
		1x		558 0063 10			
1x		558 0066 10					
1x		559 0193 10					
1x		559 0193 30					
FAG		 right		821 0628 10			
					 left		821 0627 10
				713 6405 50			
		 90 mm		713 6405 60			
		 ;  1.600 2.000kg; 		713 6405 70			
		 ;  1.200 1.400 1.600kg; 		771 0573 30			
				814 0157 10			
				814 0158 10			
				818 0012 10			
				818 0479 10			
				818 0473 10			
		 ↔;  ; OPTION		818 0480 10			
				825 0277 10			
				840 0388 10			
		 right		840 1050 10			
		 left		840 1055 10			
		2.2 HDi 130 4HH (P22DTE); (96kW)	03.11-	LUK	 PUMA 22DT;  MLGUC14		626 3075 00
					SAC		626 3075 00
				 ; A/C für Fahrzeuge mit hydraulischer Servolenkung		529 0301 10	
							 ; A/C für Fahrzeuge mit hydraulischer Servolenkung
				 ; A/C		532 0470 10	
				 ; A/C		532 0477 10	
				 ; A/C		534 0308 10	
				# F-554766.XX		535 0160 10	
				 DW12RU*		535 0317 10	
				# F-602952.XX		FB 4EPK922	
				 ; A/C		FB 6EPK873	
				 ; A/C		FB 6PK1670	
				 22DT		538 0465 10	
				FAG		 right	
 left		821 0627 10					





























			<p>SCHAEFFLER</p>
--	--	--	--------------------------

PEUGEOT

Boxer III

























































2.2 HDi 130
 4HH (P22DTE); (96kW)

03.11-

FAG			713 6405 50
			713 6405 60
			713 6405 70
			814 0157 10
			814 0158 10
			818 0012 10
			818 0479 10
			818 0473 10
			818 0480 10
			825 0277 10
			840 0388 10
			840 1050 10
			840 1055 10











































2.2 HDi 150
 4HJ (P22DTE); (110kW)

03.11-

LUK			626 3075 00	
				529 0301 10
				529 0301 30
				532 0470 10
				532 0477 10
				534 0308 10
				535 0160 10
				FB 4EPK922
				FB 6EPK873
				FB 6PK1640
				FB 6PK1670
			538 0465 10	
	FAG			821 0628 10
				821 0627 10
			713 6405 50	
			713 6405 60	
			713 6405 70	
			771 0552 30	
			814 0157 10	
			814 0158 10	
			818 0012 10	
			818 0479 10	
		818 0473 10		
		818 0480 10		
		825 0277 10		
		840 0388 10		
		840 1050 10		
		840 1055 10		

3.0 HDi 145
 F1CE3481N (F30DTE); (107kW)















































































































04.10-

LUK			626 3033 33	
				415 0375 10
				529 0267 10
				531 0812 10
				535 0103 10
				535 0176 10
				FB 4EPK1102
				538 0472 10
				821 0628 10
				821 0627 10
				713 6405 50
	FAG			713 6405 60
				713 6405 70
				814 0157 10
			814 0158 10	
			818 0012 10	
			818 0479 10	
			818 0473 10	
			818 0480 10	
			825 0277 10	
			840 0388 10	



			SCHAEFFLER
--	--	--	-------------------

PEUGEOT

Boxer III							
3.0 HDi 145 F1CE3481N (F30DTE); (107kW)	04.10-	FAG	 right  left	 840 1050 10  840 1055 10			
			LUK SAC  A/C F# F-550532.XX F-556500.XX F# F-559894.XX A/C	 626 3033 33  415 0375 10  411 0170 10  529 0267 10  531 0812 10  535 0103 10  535 0176 10 A/C  FB 4EPK1102			
FAG  right  left  90 mm  ;  1.600 2.000kg;   ;  1.200 1.400 1.600kg;           ; OPTION      right  left	 821 0628 10  821 0627 10  Set 713 6405 50  Set 713 6405 60  Set 713 6405 70  771 0552 30  814 0157 10  814 0158 10  818 0012 10  818 0479 10  818 0473 10  818 0480 10  825 0277 10  840 0388 10  840 1050 10  840 1055 10						
	3.0 HDi F1CE0481D (F30DT); (115kW)	07.06-		LUK	SAC	 626 3033 33  415 0375 10  411 0170 10  529 0267 10  531 0812 10  535 0103 10  535 0176 10 A/C  FB 4EPK1102	
					FAG  right  left          ; OPTION      right  left	 821 0628 10  821 0627 10  771 0552 30  814 0157 10  814 0158 10  818 0012 10  818 0479 10  818 0473 10  818 0480 10  825 0277 10  840 0388 10  840 1050 10  840 1055 10	
	3.0 HDi 160 F1CE0481D (F30DT); (116kW)	04.06-		LUK		SAC	 626 3033 33  415 0375 10  411 0170 10  529 0267 10  531 0812 10  535 0103 10  535 0176 10 A/C  FB 4EPK1102  538 0472 10
						FAG  right  left  90 mm  ;  1.600 2.000kg; 	 821 0628 10  821 0627 10  Set 713 6405 50  Set 713 6405 60



			SCHAEFFLER
--	---	--	-------------------

PEUGEOT

Boxer III

3.0 HDi 160 F1CE0481D (F30DT); (116kW)	04.06-	FAG	1.200 1.400 1.600kg;	Set	713 6405 70			
					771 0552 30			
					814 0157 10			
					814 0158 10			
					818 0012 10			
					818 0479 10			
					818 0473 10			
			; ; OPTION		818 0480 10			
					825 0277 10			
					840 0388 10			
			right		840 1050 10			
			left		840 1055 10			
			3.0 D (116kW)	09.08-12.09	FAG	# F-550532.XX F-556500.XX		535 0103 10
						# F-559894.XX		535 0176 10
						right		821 0628 10
left		821 0627 10						
		814 0157 10						
		814 0158 10						
		818 0012 10						
		818 0479 10						
		818 0473 10						
; ; OPTION		818 0480 10						
		825 0277 10						
		840 0388 10						
right		840 1050 10						
left		840 1055 10						
3.0 HDi 175 F1CE3481E (F30DTE); (130kW)	03.11-	LUK				SAC		626 3033 33
				415 0375 10				
				411 0170 10				
			A/C		529 0267 10			
				531 0812 10				
			# F-550532.XX F-556500.XX		535 0103 10			
			# F-559894.XX		535 0176 10			
			A/C		FB 4EPK1102			
			F30DT		538 0472 10			
			FAG	right		821 0628 10		
				left		821 0627 10		
				90 mm	Set	713 6405 50		
				1.600 2.000kg;	Set	713 6405 60		
				1.200 1.400 1.600kg;	Set	713 6405 70		
						814 0157 10		
		814 0158 10						
		818 0012 10						
		818 0479 10						
		818 0473 10						
; ; OPTION		818 0480 10						
		825 0277 10						
		840 0388 10						
right		840 1050 10						
left		840 1055 10						



















































































































Expert

1.6 HDi 90 16V 9HU (DV6UTED4); (66kW)	01.07-	LUK	BE4R		624 3218 00
				530 0375 10	
				530 0375 30	
				531 0555 10	
				532 0321 10	
			; A/C		529 0046 10
			; A/C		529 0404 10
			; A/C; 1x		532 0538 10
			; A/C; 2x		
					534 0400 10
			# F-232369.04/.05/.07 F-232369.08		535 0059 10
			# F-236591.01/.02/.04 F-236591.06		535 0062 10
			# F-232369.02/.03 F-232369.09/.11		535 0179 10
			# F-236591.05/.07		535 0194 10
					544 0104 10



			SCHAEFFLER
--	--	--	-------------------

PEUGEOT

























































































































Expert					
1.6 HDi 90 16V 9HU (DV6UTED4); (66kW)	01.07-				544 0104 20
					538 0037 10
					428 0032 30
			1x		559 0106 10
			FAG 		821 0718 10
					821 0717 10
					713 0014 20
					713 6405 40
			 86 mm		713 6405 20
					713 6405 30
			 ; 		814 0125 10
			 ; STANDARD		814 0126 10
					818 0011 10
					818 0375 10
					840 0332 10
					840 1062 10
					623 3325 00
			1.6 HDi 90 8V 9HH (DV6DUM); 9HM (DV6UC); (66kW)	01.07-	
		530 0612 10			
		530 0578 30			
		530 0612 30			
		531 0850 10			
		531 0884 10			
		532 0624 10			
		529 0046 10			
		529 0404 10			
		532 0538 10			
		534 0400 10			
		544 0104 10			
		544 0104 20			
		538 0037 10			
		420 0086 10			
8x					
 12 mm					
8x		422 0018 10			
1x		428 0183 10			
FAG 		821 0718 10			
		821 0717 10			
		713 6405 40			
 86 mm		713 6405 20			
		713 6405 30			
 ; STANDARD		814 0125 10			
 ; STANDARD		814 0126 10			
		818 0011 10			
		818 0375 10			
		840 0332 10			
		840 1062 10			
		624 3898 00			
2.0 HDi 100 DW10 (72kW)	03.11-				535 0059 10
					535 0149 10
					535 0179 10
					535 0194 10
			 START ; ORGA 14299U9→		535 0317 10
					
					
					544 0095 10
					538 0102 10
			16x; 		420 0232 10
			 12 mm		
			8x; 		422 0124 10
			8x; 		422 0125 10
			FAG 		821 0718 10
					821 0717 10
					713 0014 20
					713 6405 40
			 86 mm		



			SCHAEFFLER
--	--	--	-------------------

PEUGEOT























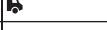















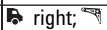

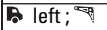





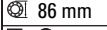







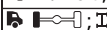













Expert

2.0 HDi 100 115 (72kW)	03.11-	FAG	 ; 	 Set	713 6405 20
			 ; 	 Set	713 6405 30
			 ;  ; I:STANDARD		814 0125 10
			 ;  ; I:STANDARD		814 0126 10
					818 0011 10
			 ; 		818 0375 10
					840 0332 10
					840 1062 10
					600 0136 00
					624 3267 00
					415 0320 10
					411 0159 10
					530 0449 10
					530 0449 30
			2.0 HDi 120 115 RHK (DW10UTED4); (88kW)	01.07-	LUK
 ML6C SAC		624 3267 00			
		415 0320 10			
		411 0159 10			
		530 0449 10			
		530 0449 30			
		531 0756 10			
		532 0473 10			
		529 0105 10			
 ; A/C		532 0650 10			
 # F-232369.04/.05/.07 F-232369.08		535 0059 10			
 # F-236591.01/.02/.04 F-236591.06		535 0062 10			
 # F-550426.XX		535 0149 10			
 # F-232369/.02/.03 F-232369.09/.11		535 0179 10			
 # F-236591.05/.07		535 0194 10			
		544 0095 10			
		544 0097 10			
		544 0097 20			
		538 0428 10			
 16x  12 mm		420 0232 10			
 16x 		422 0238 10			
 ; 1x		428 0160 10			
 ; 1x		428 0168 10			
 1x		559 0111 10			
FAG	 right; 		821 0718 10		
	 left; 		821 0717 10		
			713 0014 20		
			713 6405 40		
	 86 mm		713 6405 20		
			713 6405 30		
	 ; 		771 0603 30		
	 left; G6		814 0125 10		
	 ; I:STANDARD		814 0126 10		
	 ; I:STANDARD		818 0011 10		
			818 0375 10		
			840 0332 10		
			840 1062 10		
			530 0449 10		
	2.0 HDi 120 4x4 115 RHK (DW10UTED4); (88kW)	01.10-	INA		
					531 0756 10
					532 0473 10
					529 0105 10
					535 0062 10
					535 0149 10
					535 0179 10
					535 0194 10
					544 0097 10
					544 0097 20
					420 0232 10
16x 12 mm					422 0238 10
16x					428 0160 10
					428 0168 10
1x					559 0111 10
FAG	right;		821 0718 10		
	left;		821 0717 10		



			SCHAEFFLER
--	--	--	-------------------

PEUGEOT











































































Expert			
2.0 HDi 120 4x4 RHK (DW10UTED4); (88kW)	01.10-	FAG	 left; G6  771 0603 30
			 ; I STANDARD  814 0125 10
			 ; I STANDARD  814 0126 10
			  818 0011 10
			 ;  818 0375 10
			  840 0332 10
			  840 1062 10
			  624 3898 00
			
			
2.0 HDi 130 AHZ (DW10CD); (94kW)	03.11-	LUK	
			
			
			
			
			
			
			
			
			
		FAG	 right;  821 0718 10
			 left;  821 0717 10
			  713 0014 20
			 86 mm  Set 713 6405 40
			 ;  Set 713 6405 20
			 ;  Set 713 6405 30
			 left; G6  771 0603 30
			 ; I STANDARD  814 0125 10
			 ; I STANDARD  814 0126 10
			  818 0011 10
 ;  818 0375 10			
  840 0332 10			
  840 1062 10			
2.0 HDi 130 4x4 AHZ (DW10CD); (94kW)	01.12-		
			
			
			
			
			
			
			
			
			
2.0 HDi 140 RHR (DW10BTED4); (100kW)	01.07-	LUK	incl.  ; SAC  600 0136 00
			SAC  624 3267 00
			 415 0320 10



			SCHAEFFLER
--	--	--	-------------------

PEUGEOT

Expert



<p>2.0 HDi 140  RHR (DW10BTED4); (100kW)</p>	<p>01.07-</p>	<p> </p>	<p> 411 0159 10  530 0449 10  530 0449 30  531 0756 10  532 0473 10  529 0105 10  532 0650 10  535 0059 10  535 0062 10  535 0149 10  535 0179 10  535 0194 10  544 0095 10  544 0097 10  544 0097 20  538 0428 10  420 0232 10 16x; ORGA 12075 →  12 mm 16x; ORGA →12074  12 mm 16x; ORGA 12075 →  422 0238 10  428 0160 10  428 0168 10 1x  559 0111 10 FAG  right;  left;  713 0014 20  Set 713 6405 40  Set 713 6405 20  Set 713 6405 30  left; G6  I STANDARD 814 0125 10  I STANDARD 814 0126 10  818 0011 10  818 0375 10  840 0332 10  840 1062 10  623 3043 21</p>	
<p>2.0 16V  RFH (EW10A); RFJ (EW10A); (103kW)</p>	<p>01.07-</p>	<p> </p>	<p> BE4R incl.  BE4R  512 0018 10  530 0471 10  530 0471 30  531 0770 10  532 0289 10  529 0214 10  538 0500 10  420 0105 10 16x  28,37 mm FAG  right;  left;  713 0014 20  Set 713 6405 40  Set 713 6405 20  Set 713 6405 30  I STANDARD 814 0125 10  I STANDARD 814 0126 10  818 0011 10  818 0375 10  840 0332 10  840 1062 10  624 3417 00</p>	
<p>2.0 HDi 165  RHH (DW10CTED4); (120kW)</p>	<p>09.09-</p>	<p> </p>	<p>SAC  415 0529 10  411 0159 10  530 0558 10  530 0558 31  531 0839 10</p>	



			SCHAEFFLER
--	--	--	-------------------

PEUGEOT

Expert																																																											
2.0 HDi 165 RHH (DW10CTED4); (120kW)	09.09-	 FAG	<table border="1"> <tr><td></td><td>532 0473 10</td></tr> <tr><td></td><td>529 0291 10</td></tr> <tr><td></td><td>535 0194 10</td></tr> <tr><td></td><td>544 0097 10</td></tr> <tr><td></td><td>544 0097 20</td></tr> <tr><td></td><td>538 0102 10</td></tr> <tr><td></td><td>420 0232 10</td></tr> <tr><td>16x </td><td></td></tr> <tr><td> 12 mm</td><td></td></tr> <tr><td>8x; </td><td> 422 0124 10</td></tr> <tr><td>8x; </td><td> 422 0125 10</td></tr> <tr><td>1x; </td><td> 428 0189 10</td></tr> <tr><td>1x; </td><td> 428 0190 10</td></tr> <tr><td>1x</td><td> SKIT 559 0111 10</td></tr> <tr><td> right; </td><td> 821 0718 10</td></tr> <tr><td> left; </td><td> 821 0717 10</td></tr> <tr><td></td><td> 713 0014 20</td></tr> <tr><td></td><td> Set 713 6405 40</td></tr> <tr><td> 86 mm</td><td></td></tr> <tr><td> ; </td><td> Set 713 6405 20</td></tr> <tr><td> ; </td><td> Set 713 6405 30</td></tr> <tr><td> left; G6</td><td> 771 0603 30</td></tr> <tr><td> ; STANDARD</td><td> 814 0125 10</td></tr> <tr><td> ; STANDARD</td><td> 814 0126 10</td></tr> <tr><td></td><td> 818 0011 10</td></tr> <tr><td> ; </td><td> 818 0375 10</td></tr> <tr><td></td><td> 840 0332 10</td></tr> <tr><td></td><td> 840 1062 10</td></tr> </table>		532 0473 10		529 0291 10		535 0194 10		544 0097 10		544 0097 20		538 0102 10		420 0232 10	16x 		12 mm		8x;	422 0124 10	8x;	422 0125 10	1x;	428 0189 10	1x;	428 0190 10	1x	SKIT 559 0111 10	right;	821 0718 10	left;	821 0717 10		713 0014 20		Set 713 6405 40	86 mm		;	Set 713 6405 20	;	Set 713 6405 30	left; G6	771 0603 30	; STANDARD	814 0125 10	; STANDARD	814 0126 10		818 0011 10	;	818 0375 10		840 0332 10		840 1062 10
	532 0473 10																																																										
	529 0291 10																																																										
	535 0194 10																																																										
	544 0097 10																																																										
	544 0097 20																																																										
	538 0102 10																																																										
	420 0232 10																																																										
16x 																																																											
12 mm																																																											
8x;	422 0124 10																																																										
8x;	422 0125 10																																																										
1x;	428 0189 10																																																										
1x;	428 0190 10																																																										
1x	SKIT 559 0111 10																																																										
right;	821 0718 10																																																										
left;	821 0717 10																																																										
	713 0014 20																																																										
	Set 713 6405 40																																																										
86 mm																																																											
;	Set 713 6405 20																																																										
;	Set 713 6405 30																																																										
left; G6	771 0603 30																																																										
; STANDARD	814 0125 10																																																										
; STANDARD	814 0126 10																																																										
	818 0011 10																																																										
;	818 0375 10																																																										
	840 0332 10																																																										
	840 1062 10																																																										

EXPERT (222/223/224)																																																																																																																																											
2.0 RFN (EW10J4); (100kW)	09.02-12.06	  FAG	<table border="1"> <tr><td></td><td>BE4R</td><td></td><td>623 3043 00</td></tr> <tr><td></td><td>BE4R ; RHD</td><td></td><td>623 3043 21</td></tr> <tr><td></td><td>incl. </td><td></td><td></td></tr> <tr><td></td><td>BE4R ; RHD</td><td></td><td>512 0018 10</td></tr> <tr><td></td><td></td><td></td><td>530 0238 10</td></tr> <tr><td></td><td></td><td></td><td>530 0238 30</td></tr> <tr><td></td><td></td><td></td><td>531 0546 10</td></tr> <tr><td></td><td></td><td></td><td>532 0289 10</td></tr> <tr><td> ; →11.05; A/C</td><td></td><td></td><td>529 0184 10</td></tr> <tr><td> ; →11.05</td><td></td><td></td><td>532 0439 10</td></tr> <tr><td> ; 11.05→</td><td></td><td></td><td>532 0705 10</td></tr> <tr><td></td><td></td><td></td><td>534 0022 10</td></tr> <tr><td> ; A/C</td><td></td><td></td><td>FB 6PK1190</td></tr> <tr><td> ; A/C</td><td></td><td></td><td>FB 6PK1708</td></tr> <tr><td></td><td></td><td></td><td>538 0500 10</td></tr> <tr><td>16x </td><td></td><td></td><td>420 0105 10</td></tr> <tr><td> 28,37 mm</td><td></td><td></td><td></td></tr> <tr><td> right; ORGA →06943</td><td></td><td></td><td>821 0409 10</td></tr> <tr><td> right; ORGA 06944→ORGA →10829</td><td></td><td></td><td>821 0425 10</td></tr> <tr><td> left; ORGA →06943</td><td></td><td></td><td>821 0408 10</td></tr> <tr><td> left; ORGA 06944→ORGA →10829</td><td></td><td></td><td>821 0424 10</td></tr> <tr><td></td><td></td><td></td><td>713 0014 20</td></tr> <tr><td></td><td></td><td> Set</td><td>713 6305 80</td></tr> <tr><td> 82,5 mm</td><td></td><td></td><td></td></tr> <tr><td> ; ABS</td><td></td><td> Set</td><td>713 6305 70</td></tr> <tr><td> ; ABS</td><td></td><td> Set</td><td>713 6505 30</td></tr> <tr><td></td><td></td><td></td><td>771 0054 30</td></tr> <tr><td> 99 mm</td><td></td><td></td><td></td></tr> <tr><td></td><td></td><td></td><td>814 0125 10</td></tr> <tr><td></td><td></td><td></td><td>814 0126 10</td></tr> <tr><td></td><td></td><td></td><td>818 0233 10</td></tr> <tr><td></td><td></td><td></td><td>840 0209 10</td></tr> <tr><td> ; ORGA →9792</td><td></td><td></td><td>840 0923 10</td></tr> <tr><td> ; ORGA 9793→</td><td></td><td></td><td>840 1003 10</td></tr> </table>		BE4R		623 3043 00		BE4R ; RHD		623 3043 21		incl.				BE4R ; RHD		512 0018 10				530 0238 10				530 0238 30				531 0546 10				532 0289 10	; →11.05; A/C			529 0184 10	; →11.05			532 0439 10	; 11.05→			532 0705 10				534 0022 10	; A/C			FB 6PK1190	; A/C			FB 6PK1708				538 0500 10	16x 			420 0105 10	28,37 mm				right; ORGA →06943			821 0409 10	right; ORGA 06944→ORGA →10829			821 0425 10	left; ORGA →06943			821 0408 10	left; ORGA 06944→ORGA →10829			821 0424 10				713 0014 20			Set	713 6305 80	82,5 mm				; ABS		Set	713 6305 70	; ABS		Set	713 6505 30				771 0054 30	99 mm							814 0125 10				814 0126 10				818 0233 10				840 0209 10	; ORGA →9792			840 0923 10	; ORGA 9793→			840 1003 10
	BE4R		623 3043 00																																																																																																																																								
	BE4R ; RHD		623 3043 21																																																																																																																																								
	incl.																																																																																																																																										
	BE4R ; RHD		512 0018 10																																																																																																																																								
			530 0238 10																																																																																																																																								
			530 0238 30																																																																																																																																								
			531 0546 10																																																																																																																																								
			532 0289 10																																																																																																																																								
; →11.05; A/C			529 0184 10																																																																																																																																								
; →11.05			532 0439 10																																																																																																																																								
; 11.05→			532 0705 10																																																																																																																																								
			534 0022 10																																																																																																																																								
; A/C			FB 6PK1190																																																																																																																																								
; A/C			FB 6PK1708																																																																																																																																								
			538 0500 10																																																																																																																																								
16x 			420 0105 10																																																																																																																																								
28,37 mm																																																																																																																																											
right; ORGA →06943			821 0409 10																																																																																																																																								
right; ORGA 06944→ORGA →10829			821 0425 10																																																																																																																																								
left; ORGA →06943			821 0408 10																																																																																																																																								
left; ORGA 06944→ORGA →10829			821 0424 10																																																																																																																																								
			713 0014 20																																																																																																																																								
		Set	713 6305 80																																																																																																																																								
82,5 mm																																																																																																																																											
; ABS		Set	713 6305 70																																																																																																																																								
; ABS		Set	713 6505 30																																																																																																																																								
			771 0054 30																																																																																																																																								
99 mm																																																																																																																																											
			814 0125 10																																																																																																																																								
			814 0126 10																																																																																																																																								
			818 0233 10																																																																																																																																								
			840 0209 10																																																																																																																																								
; ORGA →9792			840 0923 10																																																																																																																																								
; ORGA 9793→			840 1003 10																																																																																																																																								



















































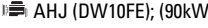

















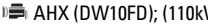





EXPERT Box															
1.5 BlueHDi 100 1.5 BlueHDi 120 YHR (DV5RUCd); YHV (DV5RUC); (75-88kW)	06.18-		<table border="1"> <tr><td></td><td>START ; ORGA 14299U9→</td><td></td><td>532 0874 10</td></tr> <tr><td></td><td>## F-602952.XX</td><td></td><td>535 0317 10</td></tr> <tr><td></td><td></td><td></td><td>FB 6PK1153</td></tr> </table>		START ; ORGA 14299U9→		532 0874 10		## F-602952.XX		535 0317 10				FB 6PK1153
	START ; ORGA 14299U9→		532 0874 10												
	## F-602952.XX		535 0317 10												
			FB 6PK1153												



			<p>SCHAEFFLER</p>
--	---	--	--------------------------

PEUGEOT

EXPERT Box



























<p>1.6 BlueHDi 95  (DV6FDU); (70kW)</p>	<p>04.16-</p>	<p> </p>	<p> 623 3727 00  530 0698 10  530 0698 30  531 0829 10  532 0624 10  529 0335 10  534 0654 10  534 0655 10  535 0308 10 # 920725 1008725  FB 6APK1005  FB 6PK800 8x  420 0086 10  12 mm 8x  422 0018 10 1x  428 0183 10</p>	<p> </p>
<p>1.6 BlueHDi 115  (DV6FC); (85kW)</p>	<p>04.16-</p>	<p> </p>	<p> 415 0715 10  411 0166 10  530 0698 10  530 0698 30  531 0829 10  532 0624 10  529 0335 10  534 0654 10  534 0655 10  535 0308 10  FB 6APK1005  FB 6PK800 8x  420 0086 10  12 mm 8x  422 0018 10 1x  428 0183 10</p>	<p> </p>
<p>2.0 BlueHDi 120  (DW10FE); (90kW)</p>	<p>04.16-</p>	<p> </p>	<p> 530 0691 10  530 0691 30  531 0885 10  532 0473 10  529 0292 10  529 0360 10  534 0657 10  534 0658 10  535 0317 10  ORGA 14299U9→ # F-602952.XX 16x  420 0234 10  12 mm 16x  422 0107 10  86 mm</p>	<p> </p>
<p>2.0 BlueHDi 150  (DW10FD); (110kW)</p>	<p>04.16-</p>	<p> </p>	<p> 530 0691 10  530 0691 30  531 0885 10  532 0473 10  529 0292 10  529 0360 10  534 0657 10  534 0658 10  535 0317 10  ORGA 14299U9→ # F-602952.XX 16x  420 0234 10  12 mm 16x 422 0107 10 86 mm</p>	<p> </p>



































			SCHAEFFLER
--	--	--	-------------------

















PEUGEOT





























EXPERT Box

2.0 BlueHDi 180  AHH (DW10FC); AHH (DW10FDCU); (130kW)	04.16-				530 0691 10
				 	530 0691 30
				 	531 0885 10
					532 0473 10
					529 0292 10
			 START		529 0360 10
			 START ;  60 mm	 	534 0657 10
			 START ;  65 mm	 	534 0658 10
			16x  12 mm		420 0234 10
			16x	 	422 0107 10
FAG   86 mm	 Set	713 6405 40			

























EXPERT Platform/Chassis

1.6 BlueHDi 95  BHV (DV6FDU); (70kW)	09.16-				623 3727 00
					530 0698 10
				 	530 0698 30
				 	531 0829 10
					532 0624 10
			 ; A/C		529 0335 10
				 	534 0654 10
			 START	 	534 0655 10
			 START  # 920725 1008725		535 0308 10
			 START		FB 6APK1005
			 ; A/C		FB 6PK800
			8x  12 mm		420 0086 10
			8x	 	422 0018 10
			1x		428 0183 10
			FAG   86 mm	 Set	713 6405 40

2.0 BlueHDi 120  (90kW)	09.16-		 START ; ORGA 14299U9 →  # F-602952.XX		535 0317 10
			16x  12 mm		420 0234 10
			16x	 	422 0107 10
			FAG   86 mm	 Set	713 6405 40
			  G6 ;  BE4R ML6C	 SET	772 0444 30

2.0 BlueHDi 150  AHX (DW10FD); (110kW)	09.16-				530 0691 10
				 	530 0691 30
				 	531 0885 10
					532 0473 10
					529 0292 10
			 START		529 0360 10
			 START ;  60 mm	 	534 0657 10
			 START ;  65 mm	 	534 0658 10
			 START  # F-602952.XX		535 0317 10
			16x  12 mm		420 0234 10
16x	 	422 0107 10			
FAG   86 mm	 Set	713 6405 40			

PARTNER



Électrique  (49kW)	06.13-	FAG	 right		821 0429 10
			 left		821 0428 10
			  82 mm	 Set	713 6307 60
			  62 mm	 Set	713 6406 10
					818 0243 10
					825 0192 10
					840 0321 10
			 right		840 1018 10
			 left		840 1017 10
			1.4  KFV (TU3A); (54kW)	11.02-10.06	
					620 3084 00



			<p>SCHAEFFLER</p>
--	--	--	--------------------------

PEUGEOT

PARTNER





























































































































<p>1.4 KfV (TU3A); (54kW)</p>	<p>11.02-10.06</p>	<p></p>	<table border="1"> <tr><td></td><td>530 0335 10</td></tr> <tr><td></td><td>530 0335 30</td></tr> <tr><td></td><td>531 0572 10</td></tr> <tr><td> ; A/C</td><td>529 0149 10</td></tr> <tr><td> ; A/C</td><td>529 0216 10</td></tr> <tr><td></td><td>544 0145 10</td></tr> <tr><td></td><td>538 0055 10</td></tr> <tr><td> FAG</td><td>821 0465 10</td></tr> <tr><td> right</td><td>821 0466 10</td></tr> <tr><td> right; ORGA →07972</td><td>821 0470 10</td></tr> <tr><td> right; ORGA 7973→</td><td>821 0464 10</td></tr> <tr><td> left</td><td>821 0469 10</td></tr> <tr><td> left; ORGA 7973→</td><td>713 6401 80</td></tr> <tr><td></td><td>Set</td></tr> <tr><td> 82 mm</td><td>Set</td></tr> <tr><td> ; ABS</td><td>Set</td></tr> <tr><td> ; ABS ; 29; →10.04</td><td>Set</td></tr> <tr><td> ; →10.04; ABS ; 48</td><td>Set</td></tr> <tr><td> ; 11.04→; ABS</td><td>Set</td></tr> <tr><td> ; </td><td>REP</td></tr> <tr><td> ; </td><td>REP</td></tr> <tr><td></td><td>818 0278 10</td></tr> <tr><td> ↓down; ORGA →07972</td><td>825 0222 10</td></tr> <tr><td> ↓down; ORGA 7973→</td><td>825 0223 10</td></tr> <tr><td> ; I STANDARD</td><td>REP</td></tr> <tr><td> ; 2x</td><td></td></tr> <tr><td> 50,17 mm</td><td>830 0039 30</td></tr> <tr><td> ; 2x</td><td></td></tr> <tr><td> 50,2 mm</td><td>830 0042 30</td></tr> <tr><td> ; + 965900; OPTION</td><td>REP</td></tr> <tr><td> ; + 965901; OPTION</td><td>REP</td></tr> <tr><td></td><td>840 0264 10</td></tr> <tr><td></td><td>840 0922 10</td></tr> </table>		530 0335 10		530 0335 30		531 0572 10	; A/C	529 0149 10	; A/C	529 0216 10		544 0145 10		538 0055 10	FAG	821 0465 10	right	821 0466 10	right; ORGA →07972	821 0470 10	right; ORGA 7973→	821 0464 10	left	821 0469 10	left; ORGA 7973→	713 6401 80		Set	82 mm	Set	; ABS	Set	; ABS ; 29; →10.04	Set	; →10.04; ABS ; 48	Set	; 11.04→; ABS	Set	;	REP	;	REP		818 0278 10	↓down; ORGA →07972	825 0222 10	↓down; ORGA 7973→	825 0223 10	; I STANDARD	REP	; 2x		50,17 mm	830 0039 30	; 2x		50,2 mm	830 0042 30	; + 965900; OPTION	REP	; + 965901; OPTION	REP		840 0264 10		840 0922 10	<table border="1"> <tr><td></td><td>1002226</td></tr> </table>		1002226																																														
	530 0335 10																																																																																																																					
	530 0335 30																																																																																																																					
	531 0572 10																																																																																																																					
; A/C	529 0149 10																																																																																																																					
; A/C	529 0216 10																																																																																																																					
	544 0145 10																																																																																																																					
	538 0055 10																																																																																																																					
FAG	821 0465 10																																																																																																																					
right	821 0466 10																																																																																																																					
right; ORGA →07972	821 0470 10																																																																																																																					
right; ORGA 7973→	821 0464 10																																																																																																																					
left	821 0469 10																																																																																																																					
left; ORGA 7973→	713 6401 80																																																																																																																					
	Set																																																																																																																					
82 mm	Set																																																																																																																					
; ABS	Set																																																																																																																					
; ABS ; 29; →10.04	Set																																																																																																																					
; →10.04; ABS ; 48	Set																																																																																																																					
; 11.04→; ABS	Set																																																																																																																					
;	REP																																																																																																																					
;	REP																																																																																																																					
	818 0278 10																																																																																																																					
↓down; ORGA →07972	825 0222 10																																																																																																																					
↓down; ORGA 7973→	825 0223 10																																																																																																																					
; I STANDARD	REP																																																																																																																					
; 2x																																																																																																																						
50,17 mm	830 0039 30																																																																																																																					
; 2x																																																																																																																						
50,2 mm	830 0042 30																																																																																																																					
; + 965900; OPTION	REP																																																																																																																					
; + 965901; OPTION	REP																																																																																																																					
	840 0264 10																																																																																																																					
	840 0922 10																																																																																																																					
	1002226																																																																																																																					
<p>1.4 BiFuel KfV (TU3JP); (55kW)</p>	<p>04.03-10.06</p>	<p></p> <p></p>	<table border="1"> <tr><td> G5 ; MA</td><td>GearBOX</td></tr> <tr><td> MA</td><td>462 0151 10</td></tr> <tr><td></td><td>620 3084 00</td></tr> <tr><td> →3666765</td><td></td></tr> <tr><td> 3666766→</td><td></td></tr> <tr><td> →3666765</td><td></td></tr> <tr><td> 3666766→</td><td></td></tr> <tr><td> →3666765</td><td></td></tr> <tr><td> 3666766→</td><td></td></tr> <tr><td> ; →10.05; TU3JP; A/C</td><td></td></tr> <tr><td> ; 10.05→; TU3JP; A/C</td><td></td></tr> <tr><td> ; TU3A; A/C</td><td></td></tr> <tr><td> ; A/C</td><td></td></tr> <tr><td>A/C</td><td></td></tr> <tr><td></td><td></td></tr> <tr><td> ; A/C</td><td></td></tr> <tr><td> ; A/C</td><td></td></tr> <tr><td></td><td></td></tr> <tr><td>A/C ; OPTION</td><td></td></tr> <tr><td>A/C </td><td></td></tr> <tr><td> ; A/C </td><td></td></tr> <tr><td> ; A/C</td><td></td></tr> <tr><td> ; A/C </td><td></td></tr> <tr><td> ; A/C </td><td></td></tr> <tr><td> →3 666 765</td><td></td></tr> <tr><td> 3 666 766→</td><td></td></tr> <tr><td> FAG</td><td>821 0465 10</td></tr> <tr><td> right</td><td>821 0466 10</td></tr> <tr><td> right; ORGA →07972</td><td>821 0470 10</td></tr> <tr><td> right; ORGA 7973→</td><td>821 0464 10</td></tr> <tr><td> left</td><td>821 0469 10</td></tr> <tr><td> left; ORGA 7973→</td><td>713 6401 80</td></tr> <tr><td></td><td>Set</td></tr> <tr><td> 82 mm</td><td>Set</td></tr> <tr><td> ; ABS</td><td>Set</td></tr> <tr><td> ; ABS ; 29; →10.04</td><td>Set</td></tr> <tr><td> ; →10.04; ABS ; 48</td><td>Set</td></tr> </table>	G5 ; MA	GearBOX	MA	462 0151 10		620 3084 00	→3666765		3666766→		→3666765		3666766→		→3666765		3666766→		; →10.05; TU3JP; A/C		; 10.05→; TU3JP; A/C		; TU3A; A/C		; A/C		A/C				; A/C		; A/C				A/C ; OPTION		A/C		; A/C		; A/C		; A/C		; A/C		→3 666 765		3 666 766→		FAG	821 0465 10	right	821 0466 10	right; ORGA →07972	821 0470 10	right; ORGA 7973→	821 0464 10	left	821 0469 10	left; ORGA 7973→	713 6401 80		Set	82 mm	Set	; ABS	Set	; ABS ; 29; →10.04	Set	; →10.04; ABS ; 48	Set	<table border="1"> <tr><td></td><td>530 0016 10</td></tr> <tr><td></td><td>530 0335 10</td></tr> <tr><td></td><td>530 0016 30</td></tr> <tr><td></td><td>530 0335 30</td></tr> <tr><td></td><td>531 0030 10</td></tr> <tr><td></td><td>531 0572 10</td></tr> <tr><td></td><td>529 0109 10</td></tr> <tr><td></td><td>529 0149 10</td></tr> <tr><td></td><td>529 0216 10</td></tr> <tr><td></td><td>531 0241 10</td></tr> <tr><td></td><td>532 0331 10</td></tr> <tr><td></td><td>534 0179 10</td></tr> <tr><td></td><td>544 0145 10</td></tr> <tr><td></td><td>FB 5PK1219</td></tr> <tr><td></td><td>FB 5PK1255</td></tr> <tr><td></td><td>FB 5PK725</td></tr> <tr><td></td><td>FB 5PK860</td></tr> <tr><td></td><td>FB 10X710</td></tr> <tr><td></td><td>538 0009 10</td></tr> <tr><td></td><td>538 0055 10</td></tr> </table>		530 0016 10		530 0335 10		530 0016 30		530 0335 30		531 0030 10		531 0572 10		529 0109 10		529 0149 10		529 0216 10		531 0241 10		532 0331 10		534 0179 10		544 0145 10		FB 5PK1219		FB 5PK1255		FB 5PK725		FB 5PK860		FB 10X710		538 0009 10		538 0055 10
G5 ; MA	GearBOX																																																																																																																					
MA	462 0151 10																																																																																																																					
	620 3084 00																																																																																																																					
→3666765																																																																																																																						
3666766→																																																																																																																						
→3666765																																																																																																																						
3666766→																																																																																																																						
→3666765																																																																																																																						
3666766→																																																																																																																						
; →10.05; TU3JP; A/C																																																																																																																						
; 10.05→; TU3JP; A/C																																																																																																																						
; TU3A; A/C																																																																																																																						
; A/C																																																																																																																						
A/C																																																																																																																						
; A/C																																																																																																																						
; A/C																																																																																																																						
A/C ; OPTION																																																																																																																						
A/C																																																																																																																						
; A/C																																																																																																																						
; A/C																																																																																																																						
; A/C																																																																																																																						
; A/C																																																																																																																						
→3 666 765																																																																																																																						
3 666 766→																																																																																																																						
FAG	821 0465 10																																																																																																																					
right	821 0466 10																																																																																																																					
right; ORGA →07972	821 0470 10																																																																																																																					
right; ORGA 7973→	821 0464 10																																																																																																																					
left	821 0469 10																																																																																																																					
left; ORGA 7973→	713 6401 80																																																																																																																					
	Set																																																																																																																					
82 mm	Set																																																																																																																					
; ABS	Set																																																																																																																					
; ABS ; 29; →10.04	Set																																																																																																																					
; →10.04; ABS ; 48	Set																																																																																																																					
	530 0016 10																																																																																																																					
	530 0335 10																																																																																																																					
	530 0016 30																																																																																																																					
	530 0335 30																																																																																																																					
	531 0030 10																																																																																																																					
	531 0572 10																																																																																																																					
	529 0109 10																																																																																																																					
	529 0149 10																																																																																																																					
	529 0216 10																																																																																																																					
	531 0241 10																																																																																																																					
	532 0331 10																																																																																																																					
	534 0179 10																																																																																																																					
	544 0145 10																																																																																																																					
	FB 5PK1219																																																																																																																					
	FB 5PK1255																																																																																																																					
	FB 5PK725																																																																																																																					
	FB 5PK860																																																																																																																					
	FB 10X710																																																																																																																					
	538 0009 10																																																																																																																					
	538 0055 10																																																																																																																					



			SCHAEFFLER
--	--	--	-------------------

PEUGEOT

PARTNER





















































































































1.4 BiFuel  KFW (TU3JP); (55kW)	04.03-10.06	FAG 	 ; 11.04→; ABS	 Set	713 6404 60
			 ; G5	 SET	772 0292 30
			 ; 	 REP	815 0004 30
			 ; 	 REP	815 0005 30
					818 0278 10
			 down; ORGA →07972		825 0222 10
			 down; ORGA 7973→		825 0223 10
			 ;  STANDARD	 REP	830 0038 30
			 ; 2x		830 0039 30
			 50,17 mm		
			 ; 2x		830 0042 30
			 50,2 mm		
			 ; + 965900; OPTION	 REP	830 0051 30
			 ; + 965901; OPTION		
					840 0264 10
					840 0922 10
					1002226
1.6 HdI 75  9HW (DV6BTED4); (55kW)	08.05-07.08	LUK 	 BE4R		624 3218 00
			 BE4R ; RHD incl. 		624 3218 21
				530 0375 10	
				530 0375 30	
				531 0555 10	
				532 0321 10	
				529 0046 10	
				529 0404 10	
				532 0538 10	
				534 0400 10	
				535 0059 10	
				535 0062 10	
				535 0179 10	
				535 0194 10	
				544 0104 10	
				544 0104 20	
				538 0037 10	
			428 0032 30		
		FAG 	 right		821 0468 10
			 left		821 0467 10
			 82 mm		713 6401 80
			 ; ABS	 Set	713 6305 30
			 ; ABS	 Set	713 6404 60
					771 0436 30
			 ; G5 ;  MC BE4R	 SET	772 0444 30
			 ; 	 REP	815 0004 30
			 ; 	 REP	815 0005 30
			818 0278 10		
 ;  STANDARD	 REP		830 0038 30		
 ; 2x			830 0039 30		
 50,17 mm					
 ; 2x			830 0042 30		
 50,2 mm					
 ; + 965900; OPTION	 REP	830 0051 30			
 ; + 965901; OPTION					
		840 0265 10			
		840 0922 10			
		1002226			
1.6 HdI  9HT (DV6BTED4); 9HT (DV6BU-TED4); 9HW (DV6BTED4); (55kW)	04.08-	LUK 	 DV6ETED4;  BE4R		623 3325 00
			 DV6B;  BE4R		624 3218 00
			 DV6B;  BE4R ; RHD incl. 		624 3218 21
				530 0375 10	
				530 0375 30	
				531 0555 10	
				532 0321 10	
	529 0046 10				
	529 0404 10				



			<p>SCHAEFFLER</p>
--	--	--	--------------------------

PEUGEOT

PARTNER

































































<p>1.6 HDi  9HT (DV6BTED4); 9HT (DV6BUTED4); 9HW (DV6BTED4); (55kW)</p>	<p>04.08-</p>	<p></p>	<p> ; A/C ; 1x  ; A/C ; 2x   # F-232369.04/.05/.07 F-232369.08  # F-236591.01/.02/.04 F-236591.06  DV6BUTED4  # F-550426.XX  # F-232369/.02/.03 F-232369.09/.11  # F-236591.05/.07 <p>1x</p> <p>FAG</p>  right  left   82 mm  62 mm      right  left</p>	<p> 532 0538 10  534 0400 10  535 0059 10  535 0062 10  535 0149 10  535 0179 10  535 0194 10  544 0104 10  544 0104 20  538 0037 10  428 0032 30  559 0106 10  821 0429 10  821 0428 10  713 0396 20  713 6307 60  713 6406 10  818 0243 10  825 0192 10  840 0321 10  840 1018 10  840 1017 10</p>
<p>1.6 HDi  9HT (DV6BTED4); (55kW)</p>	<p>01.09-</p>	<p></p>	<p> DV6ETED4;  BE4R  DV6B;  BE4R  DV6B;  BE4R ; RHD incl. </p>	<p> 623 3325 00  624 3218 00  624 3218 21   530 0375 10  530 0375 30  531 0555 10  532 0321 10  ; A/C  ; A/C  ; A/C ; 1x  ; A/C ; 2x   # F-232369.04/.05/.07 F-232369.08  # F-550426.XX  # F-232369/.02/.03 F-232369.09/.11  # F-236591.05/.07  530 0375 10  530 0375 30  531 0555 10  532 0321 10  ; A/C  ; A/C  ; A/C ; 1x  ; A/C ; 2x   # F-232369.04/.05/.07 F-232369.08  # F-550426.XX  # F-232369/.02/.03 F-232369.09/.11  # F-236591.05/.07</p>
<p>1.6 HDi / BlueHDi 75  9HK (DV6ETEDM); 9HN (DV6ETED); BHW (DV6FE); (55kW)</p>	<p>07.11-</p>	<p></p>	<p> DV6ETEDM  DV6FE   DV6ETED DV6ETEDM; +  ;   DV6ETED4 DV6ETEDM; +  ;   DV6FE  DV6ETED DV6ETEDM; +  ;   DV6ETED4 DV6ETEDM; +  ;   DV6FE  DV6FE  DV6ETED DV6ETEDM; +  ; </p>	<p> 623 3325 00  623 3727 00  530 0578 10  530 0612 10  530 0698 10  530 0578 30  530 0612 30  530 0698 30  531 0829 10  531 0850 10</p>



			SCHAEFFLER
--	--	--	-------------------

PEUGEOT

PARTNER

1.6 HDi / BlueHDi 75 9HK (DV6ETEDM); 9HN (DV6ETED); BHW (DV6FE); (55kW)	07.11-		DV6ETED4 DV6ETEDM; +  	 531 0884 10	
			DV6ETEDM; A/C	 532 0624 10  529 0261 10	
			DV6ETED; A/C	 529 0335 10	
			DV6FE; A/C	 532 0773 10	
			A/C START/STOP; DVETED	 534 0075 20	
			DV6ETEDM	 534 0427 10	
			DV6ETED	 534 0654 10  534 0655 10	
			START; DV6ETED	 535 0194 10	
			DV6FE	 535 0308 10	
			F-236591.05/.07	 544 0104 10  544 0104 20	
			START; DV6FE	 FB 6APK1005  FB 6APK1020	
			DV6ETED DV6ETEDM	 FB 6PK800	
			DV6ETED DV6ETEDM	 538 0037 10	
			START; DV6FE	 420 0086 10	
			DV6ETED	 422 0018 10	
			8x	 428 0183 10	
			12 mm	 821 0429 10  821 0428 10	
			8x	 713 6307 60	
			1x	 713 6406 10	
		FAG	right	 772 0444 30  818 0243 10	
				left	 825 0192 10  840 0321 10
				82 mm	 840 1018 10  840 1017 10
				62 mm	 624 3218 00  624 3218 21
				G5	 530 0375 10  530 0375 30
				right	 531 0555 10
				left	 532 0321 10
				BE4R	 529 0046 10  529 0404 10
				BE4R; RHD	 532 0538 10
				incl.	 534 0400 10  535 0059 10
				F-232369.04/.05/.07 F-232369.08	 535 0062 10  535 0149 10
				F-236591.01/.02/.04 F-236591.06	 535 0179 10  535 0194 10
			F-550426.XX	 544 0104 10  544 0104 20	
			F-232369/.02/.03 F-232369.09/.11	 538 0037 10  428 0032 30	
			F-236591.05/.07	 559 0106 10	
			1x	 821 0468 10  821 0467 10	
		FAG	right	 713 6401 80	
				left	 713 6305 30  713 6404 60
				82 mm	 771 0436 30
				ABS	 772 0444 30
				ABS	 815 0004 30  815 0005 30
				G5	 815 0004 30  815 0005 30
				right	
				left	
				82 mm	
				ABS	
				ABS	
				G5	
			right		
			left		



			<p>SCHAEFFLER</p>
--	---	--	--------------------------

PEUGEOT

PARTNER

































































<p>1.6 HDi 90 9HX (DV6ATED4); (66kW)</p>	<p>08.05-12.15</p>	<p>FAG</p> <ul style="list-style-type: none"> ; ISTANDARD ; 2x 50,17 mm ; 2x 50,2 mm ; + 965900; OPTION ; + 965901; OPTION 	<ul style="list-style-type: none"> 818 0278 10 830 0038 30 830 0039 30 830 0042 30 830 0051 30 840 0265 10 840 0922 10
<p>1.6 NFR (TU5JP4B); (66kW)</p>	<p>04.08-</p>	<p>RUVILLE</p> <p>LUK</p> <p>INA</p> <p>FAG</p> <ul style="list-style-type: none"> right left 82 mm 62 mm right left 	<ul style="list-style-type: none"> 1002226 620 3087 00 530 0379 10 530 0379 30 531 0632 10 532 0395 10 531 0241 10 532 0331 10 534 0447 10 544 0145 10 FB 5PK1219 FB 5PK1255 FB 5PK860 FB 6PK1203 FB 6PK1698 538 0052 10 428 0033 30 553 0272 10 821 0429 10 821 0428 10 713 0396 20 713 6307 60 713 6406 10 818 0243 10 825 0192 10 840 0321 10 840 1018 10 840 1017 10
<p>1.6 HDi 16V 9HS (DV6TED4BU); 9HX (DV6AUTED4); (66kW)</p>	<p>04.08-</p>	<p>LUK</p> <ul style="list-style-type: none"> DV6TED4BU; ORGA →12074 incl. ; incl. DV6TED4BU; ORGA →12074; BE4R DV6TED4BU; ORGA 12075→; BE4R DV6AUTED4; BE4R DV6AUTED4; BE4R ; RHD incl. DV6TED4BU; ORGA →12074; BE4R DV6TED4BU; ORGA →12074; BE4R <p>INA</p> <ul style="list-style-type: none"> ; DV6ATED; A/C ; DV6TED4; A/C ; DV6ATED; A/C ; DV6ATED; A/C ; 1x ; DV6ATED; A/C ; 2x ; DV6TED4 ; DV6ATED # F-232369.04/.05/.07 F-232369.08 # F-236591.01/.02/.04 F-236591.06 # F-550426.XX # F-232369/.02/.03 F-232369.09/.11 # F-236591.05/.07 ; DV6TED4; A/C 	<ul style="list-style-type: none"> 600 0084 00 623 3241 00 623 3325 00 624 3218 00 624 3218 21 415 0396 10 411 0166 10 530 0375 10 530 0375 30 531 0555 10 532 0321 10 529 0046 10 529 0261 10 529 0404 10 532 0538 10 534 0075 20 534 0400 10 535 0059 10 535 0062 10 535 0149 10 535 0179 10 535 0194 10 544 0104 10 544 0104 20 FB 6PK800



			SCHAEFFLER
--	--	--	-------------------

PEUGEOT

PARTNER













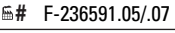













































































































<p>1.6 HDi 16V 9HS (DV6TED4BU); 9HX (DV6AUTED4); (66kW)</p>	<p>04.08-</p>	<p></p>	<p>1x right left 82 mm 62 mm right left</p>	<p> 538 0037 10  428 0032 30  559 0106 10  821 0429 10  821 0428 10  713 0396 20  713 6307 60  713 6406 10  818 0243 10  825 0192 10  840 0321 10  840 1018 10  840 1017 10</p>
<p>1.6 HDi 16V 9HS (DV6TED4BU); 9HX (DV6ATED4); (66kW)</p>	<p>01.09-</p>	<p></p> <p></p>	<p>DV6TED4BU; ORGA →12074; BE4R DV6TED4BU; ORGA 12075→; BE4R DV6AUTED4; BE4R DV6AUTED4; BE4R ; RHD incl. </p> <p>DV6ATED; A/C DV6TED4; A/C DV6ATED; A/C DV6ATED; A/C ; 1x DV6ATED; A/C ; 2x DV6TED4 DV6ATED F-232369.04/.05/.07 F-232369.08 F-236591.01/.02/.04 F-236591.06 DV6TED4BU F-550426.XX F-232369/.02/.03 F-232369.09/.11 F-236591.05/.07 DV6TED4; A/C</p> <p>right left 82 mm 62 mm right left</p>	<p> 623 3241 00  623 3325 00  624 3218 00  624 3218 21  530 0375 10  530 0375 30  531 0555 10  532 0321 10  529 0046 10  529 0261 10  529 0404 10  532 0538 10  534 0075 20  534 0400 10  535 0059 10  535 0062 10  535 0149 10  535 0179 10  535 0194 10  544 0104 10  544 0104 20  FB 6PK800  538 0037 10  428 0032 30  821 0429 10  821 0428 10  713 0396 20  713 6307 60  713 6406 10  818 0243 10  825 0192 10  840 0321 10  840 1018 10  840 1017 10</p>
<p>1.6 HDi 9HF (DV6DTE); (66kW)</p>	<p>12.11-</p>	<p></p> <p></p>	<p>SEMI ; MC EGS6 MANU ; BE4R SEMI ; MC EGS6 SEMI ; MC EGS6</p> <p>+ ; + ; + ; + ; + ; + ;</p> <p>A/C START</p>	<p> 623 3241 34  623 3325 00  415 0396 10  411 0166 10  530 0578 10  530 0612 10  530 0578 30  530 0612 30  531 0850 10  531 0884 10  532 0624 10  529 0261 10 534 0075 20 534 0427 10</p>



			<p>SCHAEFFLER</p>
--	--	--	--------------------------

PEUGEOT

PARTNER











































































































































































<p>1.6 HDi  9HF (DV6DTEd); (66kW)</p>	<p>12.11-</p>	<p></p>	<p>START/STOP  # F-236591.05/.07</p> <p>START  ; A/C</p> <p>8x  12 mm</p> <p>8x  82 mm</p> <p>1x  62 mm</p> <p>FAG  right  left  82 mm  62 mm  ; G5</p>	<p> 535 0194 10</p> <p> 544 0104 10</p> <p> 544 0104 20</p> <p> FB 6APK1020</p> <p> FB 6PK800</p> <p> 538 0037 10</p> <p> 420 0086 10</p> <p> 422 0018 10</p> <p> 428 0183 10</p> <p> 821 0429 10</p> <p> 821 0428 10</p> <p> Set 713 6307 60</p> <p> Set 713 6406 10</p> <p> 771 0436 30</p> <p> SET 772 0444 30</p> <p> 818 0243 10</p> <p> 825 0192 10</p> <p> 840 0321 10</p> <p> 840 1018 10</p> <p> 840 1017 10</p> <p> 623 3325 00</p>
<p>1.6 HDi 16V 4x4  9HS (DV6TED4BU); 9HX (DV6ATED4); 9HX (DV6AUTED4); (66kW)</p>	<p>04.12-</p>	<p></p> <p></p>	<p> DV6TED4BU;  BE4R</p> <p> ;  DV6ATED; A/C</p> <p> ;  DV6TED4; A/C</p> <p> ;  DV6ATED; A/C</p> <p> ;  DV6ATED; A/C ; 1x</p> <p> ;  DV6ATED; A/C ; 2x</p> <p> ;  DV6TED4</p> <p> ;  DV6ATED</p> <p> # F-236591.01/.02/.04 F-236591.06</p> <p> DV6TED4BU DV6AUTED4</p> <p> # F-550426.XX</p> <p> # F-232369/.02/.03 F-232369.09/.11</p> <p> # F-236591.05/.07</p> <p> ;  DV6ATED; A/C</p> <p>1x </p> <p>FAG  right  left  82 mm  62 mm  right  left</p>	<p> 530 0375 10</p> <p> KIT 530 0375 30</p> <p> 531 0555 10</p> <p> 532 0321 10</p> <p> 529 0046 10</p> <p> 529 0261 10</p> <p> 529 0404 10</p> <p> 532 0538 10</p> <p> 534 0075 20</p> <p> 534 0400 10</p> <p> 535 0062 10</p> <p> 535 0149 10</p> <p> 535 0179 10</p> <p> 535 0194 10</p> <p> 544 0104 10</p> <p> 544 0104 20</p> <p> FB 6PK800</p> <p> 538 0037 10</p> <p> 428 0032 30</p> <p> KIT 559 0106 10</p> <p> 821 0429 10</p> <p> 821 0428 10</p> <p> 818 0243 10</p> <p> 825 0192 10</p> <p> 840 0321 10</p> <p> 840 1018 10</p> <p> 840 1017 10</p> <p> 623 3241 34</p> <p> 623 3325 00</p> <p> 415 0396 10</p> <p> 411 0166 10</p> <p> KIT 530 0578 10</p> <p> KIT 530 0612 10</p> <p> KIT 530 0578 30</p> <p> KIT 530 0612 30</p> <p> 531 0850 10</p> <p> 531 0884 10</p> <p> 532 0624 10</p> <p> KIT 529 0261 10</p> <p> 534 0075 20</p> <p> START 534 0427 10</p>
<p>1.6 HDi  9HF (DV6DTEd); (66kW)</p>	<p>03.13-</p>	<p></p> <p></p>	<p> SEMI ;  MC EGS6</p> <p> MANU ;  BE4R</p> <p> SEMI ;  MC EGS6</p> <p> SEMI ;  MC EGS6</p> <p>+  ; </p> <p>+  ; </p> <p>+  ; </p> <p>+  ; </p> <p>+  ; </p> <p>+  ; </p> <p> ; A/C</p> <p> START</p>	<p> 623 3241 34</p> <p> 623 3325 00</p> <p> 415 0396 10</p> <p> 411 0166 10</p> <p> KIT 530 0578 10</p> <p> KIT 530 0612 10</p> <p> KIT 530 0578 30</p> <p> KIT 530 0612 30</p> <p> 531 0850 10</p> <p> 531 0884 10</p> <p> 532 0624 10</p> <p> KIT 529 0261 10</p> <p> 534 0075 20</p> <p> START 534 0427 10</p>



			SCHAEFFLER
--	--	--	-------------------

PEUGEOT

PARTNER



































































































































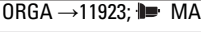













1.6 HDi  9HF (DV6DTE); (66kW)	03.13-		START/STOP  # F-236591.05/.07	 535 0194 10
			 544 0104 10  544 0104 20  FB 6APK1020  FB 6PK800  538 0037 10  420 0086 10  422 0018 10  428 0183 10  821 0429 10  821 0428 10  Set 713 6307 60  Set 713 6406 10  SET 772 0444 30  818 0243 10  825 0192 10  840 0321 10  840 1018 10  840 1017 10	 544 0104 20  FB 6APK1020  FB 6PK800  538 0037 10  420 0086 10  422 0018 10  428 0183 10  821 0429 10  821 0428 10  Set 713 6307 60  Set 713 6406 10  SET 772 0444 30  818 0243 10  825 0192 10  840 0321 10  840 1018 10  840 1017 10
1.6 HDi 90  9HJ (DV6DTE); (66kW)	04.10-		  SEMI ;  MC EGS6 ; START/STOP	 623 3241 09
			  MANU ;  BE4R	 623 3325 00
1.6 HDi 90  9HJ (DV6DTE); (66kW)	04.10-		 SEMI ;  MC EGS6 ; START/STOP	 415 0396 10
			 SEMI ;  MC EGS6 ; START/STOP	 411 0166 10
1.6  5FK (EP6CB); (72kW)	11.10-		 +  ;  	 530 0578 10
			 +  ;  	 530 0612 10
1.6  5FK (EP6CB); (72kW)	11.10-		 +  ;  	 530 0578 30
			 +  ;  	 530 0612 30
1.6  5FK (EP6CB); (72kW)	11.10-		 +  ;  	 531 0850 10
			 +  ;  	 531 0884 10
1.6  5FK (EP6CB); (72kW)	11.10-		 532 0624 10	 532 0624 10
			 529 0261 10	 529 0261 10
1.6  5FK (EP6CB); (72kW)	11.10-		 532 0773 10	 532 0773 10
			 534 0075 20	 534 0075 20
1.6  5FK (EP6CB); (72kW)	11.10-		 534 0427 10	 534 0427 10
			 535 0194 10	 535 0194 10
1.6  5FK (EP6CB); (72kW)	11.10-		 544 0104 20	 544 0104 20
			 544 0104 20	 544 0104 20
1.6  5FK (EP6CB); (72kW)	11.10-		 FB 6APK1020	 FB 6APK1020
			 FB 6PK800	 FB 6PK800
1.6  5FK (EP6CB); (72kW)	11.10-		 538 0037 10	 538 0037 10
			 420 0086 10	 420 0086 10
1.6  5FK (EP6CB); (72kW)	11.10-		 422 0018 10	 422 0018 10
			 428 0183 10	 428 0183 10
1.6  5FK (EP6CB); (72kW)	11.10-		 559 0106 10	 559 0106 10
			 821 0429 10	 821 0429 10
1.6  5FK (EP6CB); (72kW)	11.10-		 821 0428 10	 821 0428 10
			 713 0396 20	 713 0396 20
1.6  5FK (EP6CB); (72kW)	11.10-		 Set 713 6307 60	 Set 713 6307 60
			 713 6406 10	 713 6406 10
1.6  5FK (EP6CB); (72kW)	11.10-		 772 0444 30	 772 0444 30
			 818 0243 10	 818 0243 10
1.6  5FK (EP6CB); (72kW)	11.10-		 825 0192 10	 825 0192 10
			 840 0321 10	 840 0321 10
1.6  5FK (EP6CB); (72kW)	11.10-		 840 1018 10	 840 1018 10
			 840 1017 10	 840 1017 10



			<p>SCHAEFFLER</p>
--	---	--	--------------------------

PEUGEOT

PARTNER















































































































<p>1.6 5FK (EP6CB); (72kW)</p>	<p>11.10-</p>		<p>  # F-560565.XX  # F-560533.XX  # F-560968.XX  EP6C  8x;  12 mm  8x;  12 mm            8x;   1x  1x </p>	<p>  534 0425 10  535 0166 10  535 0178 10  535 0193 10  544 0096 10  538 0466 10  420 0226 10  420 0229 10  422 0221 10  422 0222 10  422 0223 10  422 0224 10  422 0225 10  422 0226 10  OILP 553 0237 10  SKIT 559 0104 10  821 0429 10  821 0428 10  713 0396 20  Set 713 6307 60  Set 713 6406 10  818 0243 10  825 0192 10  840 0321 10  840 1018 10  840 1017 10 </p>
<p>1.6 BlueHDi 100 BHY (DV6FD); (73kW)</p>	<p>04.15-</p>	<p>   </p>	<p>  BE4R   530 0698 10   530 0698 30   531 0829 10  532 0624 10  ; A/C  529 0335 10   534 0654 10  START  534 0655 10  START  535 0308 10  # 920725 1008725  START  FB 6APK1005  ; A/C  FB 6PK800   538 0037 10  8x  420 0086 10  8x  422 0018 10  1x  428 0183 10 </p>	<p>  821 0429 10  821 0428 10  Set 713 6307 60  Set 713 6406 10  818 0243 10  825 0192 10  840 0321 10  840 1018 10  840 1017 10  530 0698 10  530 0698 30  531 0829 10  532 0624 10  529 0335 10  534 0654 10  534 0655 10  535 0308 10  FB 6APK1005  FB 6PK800  538 0037 10  420 0086 10  422 0018 10  428 0183 10  821 0429 10  821 0428 10  Set 713 6307 60  Set 713 6406 10  818 0243 10  825 0192 10  840 0321 10  840 1018 10  840 1017 10  530 0698 10  530 0698 30  531 0829 10  532 0624 10  529 0331 10  534 0447 10 544 0145 10 ; A/C FB 6PK1203 ; A/C FB 6PK1698 </p>
<p>1.6 NFU (TU5JP4); (80kW)</p>	<p>04.08-</p>	<p>   </p>	<p>  ORGA → 11923;  MA  BE4R   530 0379 10   530 0379 30   531 0632 10  532 0395 10  532 0331 10   534 0447 10  544 0145 10  ; A/C FB 6PK1203  ; A/C FB 6PK1698 </p>	<p>  530 0379 10  530 0379 30  531 0632 10  532 0395 10  532 0331 10  534 0447 10  544 0145 10  ; A/C FB 6PK1203  ; A/C FB 6PK1698 </p>



			SCHAEFFLER
--	--	--	-------------------

PEUGEOT

PARTNER



1.6 NFU (TU5JP4); (80kW)	04.08-				538 0052 10
					428 0033 30
			1x		553 0272 10
			 right		821 0429 10
			 left		821 0428 10
					713 0396 20
					713 6307 60
			 82 mm		713 6406 10
			 62 mm		818 0243 10
					825 0192 10
					840 0321 10
			 right		840 1018 10
			 left		840 1017 10
			1.6 HDi 9HZ (DV6TED4); (80kW)	04.08-	
→11.09		623 3241 00			
11.09→		623 3325 00			
→11.09		415 0396 10			
					530 0375 10
					530 0375 30
					531 0555 10
					532 0321 10
	 ; A/C				529 0261 10
					534 0075 20
	 # F-232369.04/.05/.07 F-232369.08				535 0059 10
	 # F-236591.01/.02/.04 F-236591.06				535 0062 10
	 # F-550426.XX				535 0149 10
	 # F-232369/.02/.03 F-232369.09/.11				535 0179 10
	 # F-236591.05/.07				535 0194 10
					544 0104 10
	 ; A/C				544 0104 20
					FB 6PK800
					538 0037 10
					428 0032 30
	 right		821 0429 10		
	 left		821 0428 10		
			713 0396 20		
	 82 mm		713 6307 60		
	 62 mm		713 6406 10		
	 ; G5		772 0444 30		
			818 0243 10		
			825 0192 10		
			840 0321 10		
	 right		840 1018 10		
 left		840 1017 10			
1.6 HDi 9HL (DV6C); (84kW)	03.13-				623 3325 00
					415 0493 10
			+  ; 		530 0578 10
			+  ; 		530 0612 10
			+  ; 		530 0578 30
			+  ; 		530 0612 30
			+  ; 		531 0850 10
			+  ; 		531 0884 10
			 ; A/C		532 0624 10
					529 0261 10
		START/STOP		534 0075 20	
		 # F-236591.05/.07		535 0194 10	
				544 0104 10	
		 ; A/C		544 0104 20	
		FB 6PK800			
		538 0037 10			
8x		420 0086 10			
12 mm					
8x		422 0018 10			



			SCHAEFFLER
--	---	--	-------------------

PEUGEOT

PARTNER



























































































































<p>1.6 HDi 9HL (DV6C); (84kW)</p>	<p>03.13-</p>	 <p>FAG</p>	<p>1x</p> <p>right</p> <p>left</p> <p>82 mm</p> <p>62 mm</p> <p>G5 ; BE4R</p> <p>right</p> <p>left</p>	<p>428 0183 10</p> <p>821 0429 10</p> <p>821 0428 10</p> <p>713 0396 20</p> <p>713 6307 60</p> <p>713 6406 10</p> <p>772 0444 30</p> <p>818 0243 10</p> <p>825 0192 10</p> <p>840 0321 10</p> <p>840 1018 10</p> <p>840 1017 10</p>
<p>1.6 5FS (EP6C); (88kW)</p>	<p>04.10-</p>	 <p>FAG</p>	<p>A/C</p> <p>A/C</p> <p>A/C</p> <p>F-560565.XX</p> <p>F-556533.XX</p> <p>F-560968.XX</p> <p>EP6C</p> <p>8x; 12 mm</p> <p>8x; 12 mm</p> <p>422 0221 10</p> <p>422 0222 10</p> <p>422 0223 10</p> <p>422 0224 10</p> <p>422 0225 10</p> <p>8x; 422 0226 10</p> <p>1x OILP 553 0237 10</p> <p>1x SKIT 559 0104 10</p> <p>right 821 0429 10</p> <p>left 821 0428 10</p> <p>713 0396 20</p> <p>713 6307 60</p> <p>82 mm 713 6406 10</p> <p>62 mm 713 6406 10</p> <p>G5 772 0444 30</p> <p>818 0243 10</p> <p>825 0192 10</p> <p>840 0321 10</p> <p>right 840 1018 10</p> <p>left 840 1017 10</p>	<p>529 0266 10</p> <p>529 0308 10</p> <p>531 0866 10</p> <p>532 0912 10</p> <p>532 0676 10</p> <p>534 0425 10</p> <p>535 0166 10</p> <p>535 0178 10</p> <p>535 0193 10</p> <p>544 0096 10</p> <p>538 0466 10</p> <p>420 0226 10</p> <p>420 0229 10</p>
<p>1.6 BlueHDi 120 BHZ (DV6FC); (88kW)</p>	<p>04.15-</p>	 <p>LUK</p>	<p>SAC</p> <p>incl.</p> <p>A/C</p> <p>START</p> <p>START</p> <p>START</p> <p>920725 1008725</p> <p>START</p> <p>A/C</p> <p>8x</p> <p>12 mm</p> <p>8x</p> <p>1x</p>	<p>624 3992 33</p> <p>415 0743 10</p> <p>530 0698 10</p> <p>530 0698 30</p> <p>531 0829 10</p> <p>532 0624 10</p> <p>529 0335 10</p> <p>534 0654 10</p> <p>534 0655 10</p> <p>535 0308 10</p> <p>FB 6APK1005</p> <p>FB 6PK800</p> <p>538 0037 10</p> <p>420 0086 10</p> <p>422 0018 10</p> <p>428 0183 10</p>



			SCHAEFFLER
--	--	--	-------------------

PEUGEOT

PARTNER

<p>1.6 BlueHDi 120  BHZ (DV6FC); (88kW)</p>	<p>04.15-</p>	<p>FAG</p>	<p> right  left  82 mm  62 mm  ; G6     right  left</p>	<p> 821 0429 10  821 0428 10  713 6307 60  713 6406 10  772 0444 30  818 0243 10  825 0192 10  840 0321 10  840 1018 10  840 1017 10</p>	
<p>1.9 D 4x4  WJY (DW8B); (51kW)</p>	<p>04.04-07.11</p>	<p>LUK   FAG</p>	<p> BE4R  BE3R     ; A/C  ; A/C   # F-232369.04/.05/.07 F-232369.08  # F-236591.01/.02/.04 F-236591.06  # F-232369/.02/.03 F-232369.09/.11  # F-236591.05/.07  →09.04; A/C  09.04→; A/C  A/C  →09.04; A/C  09.04→; A/C  A/C  ; A/C  ; A/C  right  right; ORGA →07972  right; ORGA 7973→  left  left ; ORGA 7973→   82 mm  ; ABS  ; ABS ; 29; →10.04  ; →10.04; ABS ; 48  ; 11.04→; ABS      ↓down; ORGA →07972  ↓down; ORGA 7973→  ; STANDARD  ; 2x  50,17 mm  ; 2x  50,2 mm  ; + 965900; OPTION  ; + 965901; OPTION    85,75 mm</p>	<p> 620 3081 00  620 3096 00  530 0440 10  530 0440 30  531 0780 10  532 0345 10  529 0107 10  529 0166 10  531 0263 10  535 0059 10  535 0062 10  535 0179 10  535 0194 10  544 0039 10  544 0058 10  544 0087 10  544 0039 20  544 0058 20  544 0087 20  FB 6PK1043  FB 6PK862  538 0008 10  428 0029 30  821 0465 10  821 0466 10  821 0470 10  821 0464 10  821 0469 10  713 6401 80  713 6305 30  713 6404 20  713 6404 50  713 6404 60  815 0004 30  815 0005 30  818 0278 10  825 0222 10  825 0223 10  830 0038 30  830 0039 30  830 0042 30  830 0051 30  840 0264 10  840 0922 10  75924S  428 0034 30</p>	
<p>2.0 HDi  (66kW)</p>	<p>11.02-07.08</p>	<p> FAG</p>	<p> 82 mm  ; ABS</p>	<p> 713 6401 80  713 6305 30</p>	



			SCHAEFFLER
--	--	--	-------------------

PEUGEOT

PARTNER

2.0 HDi 1) (66kW)	11.02-07.08	FAG	; ABS ; 29	Set	713 6404 20	
			; ABS ; 48	Set	713 6404 50	
				REP	815 0004 30	
				REP	815 0005 30	
					818 0278 10	
			; ISTANDARD	REP	830 0038 30	
					840 0265 10	
					840 0922 10	
					530 0470 10	
					530 0470 30	
					531 0780 10	
					532 0345 10	
					529 0017 10	
					529 0092 10	
2.0 HDi 4x4 1) RHY (DW10TD); (66kW)	04.04-08.05	INA			529 0156 10	
					529 0156 10	
					531 0148 10	
					534 0110 20	
					535 0059 10	
					535 0062 10	
					535 0179 10	
					535 0194 10	
					544 0039 10	
					544 0058 10	
					544 0039 20	
					544 0058 20	
					538 0008 10	
					428 0034 30	
					553 0128 10	
			FAG	right		821 0468 10
				left		821 0467 10
				Set	713 6401 80	
		82 mm				
		; ABS		Set	713 6305 30	
		; ABS ; 29; →10.04		Set	713 6404 20	
		; →10.04; ABS ; 48		Set	713 6404 50	
		; 11.04 →; ABS		Set	713 6404 60	
				REP	815 0004 30	
				REP	815 0005 30	
					818 0278 10	
		; ISTANDARD		REP	830 0038 30	
		; 2x			830 0039 30	
		50,17 mm				
		; 2x			830 0042 30	
		50,2 mm				
		; + 965900; OPTION		REP	830 0051 30	
		; + 965901; OPTION				
				840 0265 10		
		840 0922 10				









PARTNER Kasten (K9)

1.5 BlueHDI 130 1) YHZ (DV5RC); (96kW)	09.18-	INA			532 0874 10
					535 0194 10
					535 0317 10
1.6 BlueHDI 75 1) BHW (DV6FE); (55kW)	09.18-	INA			FB 6PK1153
					530 0698 10
					530 0698 30
					531 0829 10
					532 0624 10
			; A/C		529 0335 10
					534 0654 10
			# 920725 1008725		535 0308 10
1.6 BlueHDI 100 1) BHY (DV6FD); (73kW)	09.18-	INA			544 0104 10
					544 0104 20
			; A/C		FB 6PK800
					530 0698 10
					530 0698 30
		531 0829 10			
		532 0624 10			
		529 0335 10			



















































































			SCHAEFFLER
--	---	--	-------------------

PEUGEOT

PARTNER Kasten (K9)			
1.6 BlueHD1 100 BHY (DV6FD); (73kW)	09.18-		 534 0654 10
			 # 920725 1008725
			 535 0308 10
			 544 0104 10
			 544 0104 20
			 420 0086 10
			 422 0018 10
			 428 0183 10

RENAULT

KANGOO I (FC/KC)			
1.0 D7D 700; (43kW)	01.02-01.07		 JB1
			 D7D 700 D7D 760
			 D4D 700 D4D 720
			 D7D 700 D7D 760
			 D4D 700 D4D 720
			 D7D 700 D7D 760
			 D4D 700 D4D 720
			 D4D 700 D4D 720 D7D 700 D7D 760; A/C
			 D4D 700 D4D 720; A/C
			 D4D 700 D4D 720; A/C
			 D4D 700 D4D 720
			 D7D 700 D7D 760
			 D4D 700 D4D 720; 
			 D4D 700 D4D 720; A/C
		 D7D 700 D7D 760	
		 D4D 700 D4D 720; 	
		 D4D 700 D4D 720; A/C	
		 D4D 700 D4D 720	
		 D7D 700 D7D 760	
		FAG	 ;
 ;			
 ;  SMI,Koyo,JTEKT			
 right			
 left			
 ;			
 ;			
 ;			
1.0 D4D 700; D4D 720; (50kW)	01.02-01.07		 530 0195 10
			 530 0195 30
			 531 0404 10
			 531 0744 10
			 532 0260 10
			 FB 3PK738
			 FB 4PK928
			 FB 4PK928
		FAG	 Set 713 6308 40
			 Set 713 6309 00
			 ;
			 ;
			 ;  SMI,Koyo,JTEKT
			 right
			 left
			 ;
1.2 16V (FC05, FC0W, FC1D, FC1P, FC1K, FC0T) D4F 712; D4F 714; D4F 730; (55kW)	10.01-		 618 3091 00
			 D4F 712 D4F 730
		 D4F 712	
		 D4F 712 D4F 730	
		 A/C ; 	
		 →06.08;  BM Kangoo Express;  A/C	
		 →06.08;  BM Kangoo Rapid;  A/C	
		 A/C ; →06.08;  BM Kangoo Express; 	
		 A/C ; →06.08;  BM Kangoo Rapid; 	
		 ;  D4F 712 D4F 730; 11.05→	
		 ;  D4F 712 D4F 730; A/C	
		 ;  A/C	
		 ;  D4F 728; A/C	
		 A/C ; 	
 ;  A/C			



			SCHAEFFLER
--	--	--	-------------------

















































































RENAULT

KANGOO I (FC/KC)

1.2 16V (FC05, FC0W, FC1D, FC1P, FC1K, FC0T)

 D4F 712; D4F 714; D4F 730; (55kW)





























































































































10.01-

 FAG	 right		538 0046 10
	 left		821 0323 10
 72 mm			821 0322 10
 55 mm			713 6300 30
 ; ABS ;  26			
 ; ABS ;  44			
 right 			713 6302 70
 ;  G5 ; →10.02			
 right			713 6306 90
 right			713 6309 80
 left			772 0229 30
 left			772 0208 30
 left			812 0002 10
 left			812 0003 10
 left			812 0001 10
 left			812 0004 10
			813 0001 30
			815 0045 30
			825 0258 10
			825 0259 10
			830 0019 30
			840 0201 10
 ; SMI,Koyo,JTEKT			840 0350 10
 right			840 0876 10
 left			840 0875 10

1.5 dCi (FC1R)

 K9K 704; (42kW)

































































12.02-

  FAG	→06.08		622 3055 00
	→08.03		530 0197 10
04.04→06.08			530 0197 30
 ; A/C			530 0197 31
 ;  ; 09.07→12.07			531 0547 10
 ; →09.05; 			529 0009 10
 ; +  ; 09.07→ ; A/C			529 0178 10
 ; →09.05; 			529 0224 10
 ; →09.05; 			529 0396 10
 ; →09.05; 			531 0591 30
 ; →12.07; 			532 0354 10
 ; 12.07→ ; 			532 0678 10
 ; →01.05; A/C			534 0141 30
 ; 01.05→ ; A/C			534 0269 10
 ; 09.05→ ; 			
 # F-552973.XX F-550181.XX F-557755.XX			535 0105 10
 # F-550379 F-550379.01/.03/.04			535 0109 10
 # F-550379.02			535 0114 10
			544 0090 10
			544 0090 20
 ; →09.05; 			FB 5PK1133
 ; →01.05; A/C			FB 5PK1200
 ; 02.05→ ; A/C			FB 6PK1200
 ; 09.05→12.07; 			
04.04→			538 0047 10
→04.04			538 0373 10
1x			428 0163 10
FAG	 right		821 0323 10
	 left		821 0322 10
 72 mm			713 6300 30
 55 mm			713 6302 70
 ; ABS ;  26			713 6306 90
 ; ABS ;  44			713 6309 80
 right 			772 0229 30
 right			812 0002 10
 right			812 0003 10
 left			812 0001 10
 left			812 0004 10
			813 0001 30
			815 0045 30



			SCHAEFFLER
--	---	--	-------------------

RENAULT

KANGOO I (FC/KC)			
1.5 dCi (FC1R) K9K 704; (42kW)	12.02-	FAG	 825 0258 10
			 825 0259 10
			 REP 830 0019 30
			 840 0201 10
			 ; SMI,Koyo,JTEKT 840 0350 10
			 right 840 0876 10
			 left 840 0875 10
			 622 3096 33
			 →06.08 530 0197 10
			 →06.08 530 0197 31
			1.5 dCi K9K 716; (45kW)
 ; 12.07→; A/C 529 0009 10			
 ; 12.07→; A/C 529 0165 10			
 ; + ; →12.07; A/C 529 0224 10			
 ; →12.07; A/C 532 0354 10			
 ; A/C 534 0269 10			
 # F-552973.XX F-550181.XX F-557755.XX 535 0105 10			
 # F-550379 F-550379.01/.03/.04 535 0109 10			
 # F-550379.02 535 0114 10			
 544 0090 10			
 ; 12.07→; A/C 544 0090 20			
 ; →12.07; A/C FB 6PK1130			
 ; A/C FB 6PK1200			
 538 0047 10			
 1x 428 0163 10			
FAG	 right 821 0323 10		
	 left 821 0322 10		
	 72 mm Set 713 6300 30		
	 ; 55 mm Set 713 6302 70		
	 ; ABS ; 26 Set 713 6306 90		
	 ; ABS ; 44 Set 713 6309 80		
	 right SET 772 0229 30		
	 right 812 0002 10		
	 right 812 0003 10		
	 left 812 0001 10		
	 left 812 0004 10		
	 813 0001 30		
	 ; 814 0085 10		
	 ; 814 0092 10		
	 825 0258 10		
	 825 0259 10		
 ; 840 0201 10			
 ; SMI,Koyo,JTEKT 840 0350 10			
 right 840 0876 10			
 left 840 0875 10			
1.5 dCi (FC07, FC1R) K9K 700; K9K 702; K9K 704; (48kW)	12.01-	LUK	 622 3055 00
			 →06.08 530 0197 10
			 →08.03 530 0197 30
			 04.04→06.08 530 0197 31
			 ; A/C ; 01.05→; K9K 702 531 0547 10
			 ; A/C ; →01.05; K9K 702 529 0009 10
			 ; →09.05; A/C 529 0015 10
			 ; + ; K9K 702; 01.05→; A/C 529 0178 10
			 ; →09.05; A/C 529 0224 10
			 ; →09.05; A/C 529 0396 10
		 ; →09.05; A/C 531 0591 30	
		 ; →12.07; A/C 532 0354 10	
		 ; 12.07→; K9K 704; A/C 532 0678 10	
		 ; →01.05; A/C 534 0141 30	
		 ; 01.05→; A/C 534 0269 10	
		 ; 09.05→; A/C	
		 # F-552973.XX F-550181.XX F-557755.XX 535 0105 10	
		 # F-550379 F-550379.01/.03/.04 535 0109 10	
		 # F-550379.02 535 0114 10	
		 →04.04 544 0054 10	











































			<p>SCHAEFFLER</p>
--	--	--	--------------------------

RENAULT

KANGOO I (FC/KC)

































1.5 dCi (FC07, FC1R)
 K9K 700; K9K 702; K9K 704;
 (48kW)

12.01-

	→04.04 ; →09.05; A/C ; →01.05; A/C ; 02.05→; A/C ; 09.05→12.07; A/C 04.04→ →03.04 1x 1x	 544 0090 10  544 0054 20  544 0090 20  FB 5PK1133  FB 5PK1200  FB 6PK1200  538 0047 10  538 0373 10  428 0163 10  553 0124 10
<p>FAG</p> 	right left  72 mm   55 mm ; ABS; 26 ; ABS; 44 ; ABS right ; ABS ; G5; →10.02 right right left left    ; SMI,Koyo,JTEKT right left	 821 0323 10  821 0322 10  Set 713 6300 30  Set 713 6302 70  Set 713 6306 90  Set 713 6309 80  771 0500 30  SET 772 0229 30  SET 772 0460 30  SET 772 0208 30  812 0002 10  812 0003 10  812 0001 10  812 0004 10  813 0001 30  REP 815 0045 30  825 0258 10  825 0259 10  REP 830 0019 30  840 0201 10  840 0350 10  840 0876 10  840 0875 10

1.5 dCi (FC1E)
 K9K 714; (50kW)

06.05-

































































































































	→06.08 →06.08	 622 3096 33
	; A/C ; A/C; 09.05→12.07 ; →09.05; A/C ; →09.05; A/C ; →09.05; A/C ; →12.07; A/C ; A/C ; 09.05→; A/C # F-552973.XX F-550181.XX F-557755.XX # F-550379 F-550379.01/.03/.04 # F-550379.02	 530 0197 10  530 0197 31  531 0547 10  529 0009 10  529 0178 10  529 0396 10  531 0591 30  532 0354 10  534 0269 10  535 0105 10  535 0109 10  535 0114 10  544 0090 10  544 0090 20  FB 5PK1133  FB 6PK1200
<p>FAG</p> 	1x right left ; 01.06→  72 mm   55 mm ; ABS; 26 ; ABS; 44 right	 428 0163 10  821 0323 10  821 0322 10  713 0392 20  Set 713 6300 30  Set 713 6302 70  Set 713 6306 90  Set 713 6309 80  SET 772 0229 30



			SCHAEFFLER
--	---	--	-------------------

RENAULT

KANGOO I (FC/KC)











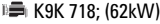



















































































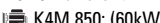























































1.5 dCi (FC1E) K9K 714; (50kW)	06.05-	FAG	 right		812 0002 10			
			 right		812 0003 10			
			 left		812 0001 10			
			 left		812 0004 10			
			 ; 		813 0001 30			
			 ; 		814 0085 10			
					825 0258 10			
					825 0259 10			
			 ; 		840 0201 10			
			 ;  ; SMI,Koyo,JTEKT		840 0350 10			
			 right		840 0876 10			
			 left		840 0875 10			
					622 3055 00			
			1.5 dCi (FC08, FC09) K9K 702; K9K 710; (60kW)	04.03-	LUK	→06.08		530 0197 10
						→08.03		530 0197 30
04.04→06.08		530 0197 31						
 ; A/C ; 01.05→		531 0547 10						
 ; A/C ; →01.05		529 0009 10						
 ; →09.05; A/C		529 0015 10						
 ; +  ; 01.05→; A/C		529 0178 10						
 ; →09.05; A/C 		529 0224 10						
 ; →09.05; A/C		529 0396 10						
 ; →09.05; A/C		531 0591 30						
 ; A/C		532 0354 10						
 ; →01.05; A/C		534 0141 30						
 ; 01.05→; A/C		534 0269 10						
 ; 09.05→; A/C								
 # F-552973.XX F-550181.XX F-557755.XX		535 0105 10						
 # F-550379 F-550379.01/03/04		535 0109 10						
 # F-550379.02		535 0114 10						
→04.04		544 0054 10						
		544 0090 10						
→04.04		544 0054 20						
		544 0090 20						
 ; →09.05; A/C		FB 5PK1133						
 ; →01.05; A/C		FB 5PK1200						
 ; 02.05→; A/C		FB 6PK1200						
 ; 09.05→12.07; A/C								
04.04→		538 0047 10						
→04.04		538 0373 10						
1x		428 0163 10						
1x		OILP 553 0124 10						
FAG	 right					821 0323 10		
	 left					821 0322 10		
	 72 mm					Set 713 6300 30		
	 ; 					Set 713 6302 70		
	 55 mm					Set 713 6306 90		
	 ; ABS ;  26					Set 713 6306 90		
	 ; ABS ;  44		Set 713 6309 80					
	 right 		SET 772 0229 30					
	 right		812 0002 10					
	 right		812 0003 10					
	 left		812 0001 10					
	 left		812 0004 10					
			813 0001 30					
			REP 815 0045 30					
			825 0258 10					
		825 0259 10						
		REP 830 0019 30						
 ; 		840 0201 10						
 ;  ; SMI,Koyo,JTEKT		840 0350 10						
 right		840 0876 10						
 left		840 0875 10						
		622 3096 33						
1.5 dCi (FC1G) K9K 718; (62kW)	06.05-	LUK			530 0197 10			
			→06.08		530 0197 31			



			<p>SCHAEFFLER</p>
--	--	--	--------------------------

RENAULT

KANGOO I (FC/KC)







































































<p>1.5 dCi (FC1G)  K9K 718; (62kW)</p>	<p>06.05-</p>	<p></p>	<p> ; A/C</p> <p> ;  ; 09.05→12.07</p> <p> ; →09.05; </p> <p> ; →09.05;  </p> <p> ; →09.05; </p> <p> ; →12.07; </p> <p> ; A/C</p> <p> ; 09.05→; </p> <p> # F-552973.XX F-550181.XX F-557755.XX</p> <p> # F-550379.02</p> <p> ; →09.05; </p> <p> ; A/C</p> <p> ; 09.05→12.07; </p> <p>1x</p> <p>FAG</p> <p> right</p> <p> left</p> <p></p> <p> 72 mm</p> <p> ; </p> <p> 55 mm</p> <p> ; ABS ;  26</p> <p> ; ABS ;  44</p> <p></p> <p></p> <p></p> <p></p> <p></p> <p></p> <p></p> <p> ; </p> <p> ;  ; SMI,Koyo,JTEKT</p> <p> right</p> <p> left</p>	<p> 531 0547 10</p> <p> 529 0009 10</p> <p> 529 0178 10</p> <p> 529 0396 10</p> <p> 531 0591 30</p> <p> 532 0354 10</p> <p> 534 0269 10</p> <p> 535 0105 10</p> <p> 535 0114 10</p> <p> 544 0090 10</p> <p> 544 0090 20</p> <p> FB 5PK1133</p> <p> FB 6PK1200</p> <p> 538 0047 10</p> <p> 428 0163 10</p> <p> 821 0323 10</p> <p> 821 0322 10</p> <p> 713 0392 20</p> <p>  713 6300 30</p> <p>  713 6302 70</p> <p>  713 6306 90</p> <p>  713 6309 80</p> <p> 814 0085 10</p> <p> 814 0092 10</p> <p> 825 0258 10</p> <p> 825 0259 10</p> <p>  830 0019 30</p> <p> 840 0201 10</p> <p> 840 0350 10</p> <p> 840 0876 10</p> <p> 840 0875 10</p> <p> 620 1080 00</p>
<p>1.6 16V bivalent  K4M 850; (60kW)</p>	<p>06.05-</p>	<p></p> <p></p>	<p>→04.11</p> <p> ; </p> <p> ; A/C</p> <p> ; A/C</p> <p> ; A/C</p> <p> # F-552973.XX F-550181.XX F-557755.XX</p> <p> # F-230147.XX</p> <p> ; A/C ;  82 00 603 359 82 00 104 754</p> <p>16x</p> <p> 12 mm</p> <p>16x</p> <p>FAG</p> <p> right</p> <p> left</p> <p></p> <p> 72 mm</p> <p> ; </p> <p> 55 mm</p> <p> ; ABS ;  26</p> <p> ; ABS ;  44</p> <p></p> <p></p> <p></p> <p></p> <p></p> <p> ; </p> <p> ;  ; SMI,Koyo,JTEKT</p> <p> right</p>	<p> 530 0640 10</p> <p> 530 0640 30</p> <p> 531 0409 30</p> <p> 532 0774 10</p> <p> 529 0145 10</p> <p> 532 0243 10</p> <p> 534 0271 10</p> <p> 535 0105 10</p> <p> 535 0116 10</p> <p> 544 0091 10</p> <p> 544 0091 20</p> <p> FB 5PK1750</p> <p> 538 0375 10</p> <p> 420 0099 10</p> <p> 422 0009 10</p> <p> 821 0323 10</p> <p> 821 0322 10</p> <p>  713 6300 30</p> <p>  713 6302 70</p> <p>  713 6306 90</p> <p>  713 6309 80</p> <p> 814 0085 10</p> <p> 814 0092 10</p> <p> 825 0258 10</p> <p> 825 0259 10</p> <p> 840 0201 10</p> <p> 840 0350 10</p> <p> 840 0876 10</p>



			SCHAEFFLER
--	---	--	-------------------

RENAULT

KANGOO I (FC/KC)































































































1.6 16V bivalent K4M 850; (60kW)	06.05-	FAG	left		840 0875 10			
1.6 16V K4M 706; K4M 752; (70kW)	10.01-				620 1080 00			
					530 0640 10			
					530 0640 30			
					531 0409 30			
					532 0774 10			
					529 0145 10			
					532 0243 10			
					534 0271 10			
					535 0105 10			
					544 0091 10			
					544 0091 20			
					FB 5PK1750			
					538 0375 10			
					420 0099 10			
					422 0009 10			
					553 0124 10			
				FAG	right		821 0323 10	
					left		821 0322 10	
					72 mm		713 6300 30	
							713 6302 70	
							713 6306 90	
							713 6309 80	
							772 0229 30	
					right		812 0002 10	
					right		812 0003 10	
					left		812 0001 10	
					left		812 0004 10	
							813 0001 30	
				815 0045 30				
				825 0258 10				
				825 0259 10				
				830 0019 30				
				840 0201 10				
				840 0350 10				
				840 0876 10				
				840 0875 10				
1.6 16V 4x4 (FC0L, FC0P, FC0S) K4M 750; K4M 752; K4M 753; (70kW)	10.01-				530 0640 10			
					530 0640 30			
					531 0409 30			
					532 0774 10			
					529 0145 10			
					532 0243 10			
					534 0271 10			
					535 0105 10			
					544 0091 10			
					544 0091 20			
					FB 5PK1750			
					538 0375 10			
					420 0099 10			
					422 0009 10			
					713 6309 20			
					815 0045 30			
					818 0313 10			
					825 0258 10			
					825 0259 10			
					830 0019 30			
					840 0405 10			
					840 0876 10			
					840 0875 10			
			1.9 dCi 4x4 (FC0V) F9Q 782; F9Q 790; (59kW)	10.01-		F9Q 782; OPTION		530 0194 10
						F9Q 782		530 0357 10
						F9Q 790		530 0473 10



			<p>SCHAEFFLER</p>
--	---	--	-------------------

RENAULT

KANGOO I (FC/KC)





















<p>1.9 dCi 4x4 (FC0V) F9Q 782; F9Q 790; (59kW)</p>	<p>10.01-</p>	<p></p>	<p>F9Q 782 F9Q 790 F9Q 782 F9Q 790 F9Q 782 F9Q 782 F9Q 782 F-228881.XX F-556599.XX ; A/C A/C 1x FAG   84 mm      right left</p>	<p> 531 0408 30  531 0761 10  532 0220 10  532 0222 10  532 0322 10  532 0443 10  535 0028 10  544 0009 10  544 0009 20  FB 6PK1125  FB 6PK1210  538 0057 10  OILP 553 0124 10  Set 713 6309 20  REP 815 0045 30  818 0313 10  825 0258 10  825 0259 10  REP 830 0019 30  840 0405 10  840 0876 10  840 0875 10  622 3036 00</p>
<p>1.9 dCi (FC0V) F9Q 782; F9Q 790; (62kW)</p>	<p>07.03-</p>	<p> </p>	<p>F9Q 782; OPTION F9Q 782 F9Q 790 F9Q 782 F9Q 790 F9Q 782 F9Q 790 F9Q 782 F9Q 782 F-228881.XX F-556599.XX ; A/C A/C FAG right left  72 mm  55 mm ; ABS ; 26 ; ABS ; 44 right right left left      ; SMI,Koyo,JTEKT right left</p>	<p> 530 0194 10  530 0357 10  530 0473 10  531 0408 30  531 0761 10  532 0220 10  532 0222 10  532 0322 10  532 0443 10  535 0028 10  FB 6PK1125  FB 6PK1218  538 0057 10  821 0323 10  821 0322 10  713 0392 20  Set 713 6300 30  Set 713 6302 70  Set 713 6306 90  Set 713 6309 80  812 0002 10  812 0003 10  812 0001 10  812 0004 10  813 0001 30  814 0085 10  814 0092 10  825 0258 10  825 0259 10  REP 830 0019 30  840 0201 10  840 0350 10  840 0876 10  840 0875 10  530 0473 10  531 0761 10  532 0222 10  535 0028 10  FB 6PK1125  FB 6PK1218  538 0057 10  713 0392 20</p>
<p>1.9 dCi 4x4 (FC0V) F9Q 790; (62kW)</p>	<p>07.03-</p>	<p></p>	<p>  F-228881.XX F-556599.XX ; A/C A/C FAG </p>	<p> 530 0473 10  531 0761 10  532 0222 10  535 0028 10  FB 6PK1125  FB 6PK1218  538 0057 10  713 0392 20</p>

















































































































			SCHAEFFLER
--	---	--	-------------------

RENAULT

KANGOO I (FC/KC)

1.9 dCi 4x4 (FC0V) F9Q 790; (62kW)	07.03-	FAG	  713 6309 20
			 84 mm
			 ;  814 0085 10
			 ;  814 0092 10
			  818 0313 10
			  825 0258 10
			  825 0259 10
			  830 0019 30
			 ↔  840 0405 10
 right  840 0876 10			
 left  840 0875 10			

KANGOO II (FW/KW)

Z.E. (FW0Z) 5AM 400; (44kW)	10.11-	FAG	 right  821 0952 10
			 left  821 0953 10
			 ;   713 6308 40
			 14 "
			 72 mm
			 ;   713 6309 00
			 15 16 "
			 83 mm
			  814 0182 10
			 ; I STANDARD  818 0208 10
			 right  825 0339 10
			 left  825 0341 10
			 ↔  840 0375 10
			 right  840 1120 10
			 left  840 1121 10
1.2 TCe 115 (FW02, FW14) H5F 400; H5F 408; H5F 412; (84kW)	07.13-	LUK	  602 0005 00
			G6   623 3701 33
			G6   415 0492 10
			 ; 02.14 →; A/C  529 0187 10
			 ; →01.14; A/C  529 0194 10
			 ; →01.14; A/C  529 0316 10
			 ; →01.14; A/C  532 0534 10
			 ; A/C  532 0668 10
			 # F-236675.XX F-561464.XX  534 0590 10
			 # F-238512.XX  535 0080 10
			 ; →01.14; A/C  535 0081 10
			 ; →01.14; A/C  FB 7PK1605
		FAG	 right  821 0952 10
			 left  821 0953 10
			 ;   713 6308 40
 14 "			
 72 mm			
 ;   713 6309 00			
 15 16 "			
 83 mm			
  814 0182 10			
 ; I STANDARD  818 0208 10			
 right  825 0339 10			
 left  825 0341 10			
 ↔  840 0375 10			
 right  840 1120 10			
 left  840 1121 10			
1.5 dCi (FW0A, KW0V) K9K 800; (50kW)	02.08-	LUK	  622 3096 09
			 JH3  622 3096 33
			 JR5  622 3096 35
			  530 0197 10
			  530 0197 31
			 ; A/C  531 0547 10
			 ; A/C  529 0009 10
			  529 0165 10
			 # F-550213.11 F-550213/.02/.08/.09  534 0269 10
			  535 0102 10
			  544 0090 10
			 ; A/C  544 0090 20
		  FB 6PK1200	
		  538 0047 10	





























			SCHAEFFLER
--	--	--	-------------------

RENAULT

KANGOO II (FW/KW)























































1.5 dCi (FW0A, KW0V)
 K9K 800; (50kW)

02.08-

	1x		428 0163 10
FAG	 right		821 0952 10
	 left		821 0953 10
	 ; 		713 6308 40
	 14 "		
	 72 mm		
	 ; 		713 6309 00
	 15 16 "		
	 83 mm		
			814 0182 10
	 ; STANDARD		818 0208 10
	 right		825 0339 10
	 left		825 0341 10
	 ↔		840 0375 10





























1.5 dCi 75 (FW07, FW10)
 K9K 608; K9K 628; (55kW)

09.10-

	 K9K 608 K9K 808		622 3096 35
	→07.15;  K9K 628		622 3427 33
	07.15→;  K9K 628		622 3429 33
	 K9K 802		530 0197 10
	 K9K 608		530 0607 10
			530 0197 32
	 K9K 608		530 0607 30
			531 0547 10
			531 0906 10
	 ; A/C		529 0009 10
	 ; A/C		529 0165 10
			534 0269 10
	 # F-550213.11 F-550213/.02/.08/.09		535 0102 10
			544 0090 10
			544 0090 20
	 ; A/C		FB 6PK1200
			538 0095 10
FAG	1x		428 0198 10
	 right		821 0952 10
	 left		821 0953 10
	 ; 		713 6308 40
	 14 "		
	 72 mm		
	 ; 		713 6309 00
	 15 16 "		
	 83 mm		
			814 0182 10
	 ; STANDARD		818 0208 10
	 right		825 0339 10
	 left		825 0341 10
	 ↔		840 0375 10

1.5 dCi 85 (FW0K, FW0L)
 K9K 812; (63kW)

02.08-

			622 3096 35	
	09.08→		530 0197 10	
			530 0197 31	
			531 0547 10	
	 ; A/C		529 0009 10	
	 ; A/C		529 0165 10	
			534 0269 10	
	 # F-550213.11 F-550213/.02/.08/.09		535 0102 10	
			544 0090 10	
			544 0090 20	
	 ; A/C		FB 6PK1200	
			538 0047 10	
	FAG	1x		428 0163 10
		 right		821 0952 10
		 left		821 0953 10
 ; 			713 6308 40	
 14 "				



			SCHAEFFLER
--	--	--	-------------------

RENAULT

KANGOO II (FW/KW)



















































































1.5 dCi 85 (FW0K, FW0L) K9K 812; (63kW)	02.08-	FAG	;		713 6309 00
			15 16 "		814 0182 10
			83 mm		818 0208 10
			; ISTANDARD		825 0339 10
			right		825 0341 10
			left		840 0375 10
			↔		840 1120 10
			right		840 1121 10
			left		840 1121 10
			;		713 6309 00
			; ISTANDARD		818 0208 10
			right		825 0339 10
			left		825 0341 10
↔		840 0375 10			
right		840 1120 10			
left		840 1121 10			
1.5 dCi 90 (FW0G, FW04, FW05, FW08, FW11) K9K 608; K9K 628; K9K 808; (66kW)	06.09-	LUK	K9K 608 K9K 808		622 3096 35
			→07.15; K9K 628		622 3427 33
			07.15→; K9K 628		622 3429 33
			K9K 808		530 0197 10
			K9K 608		530 0607 10
			K9K 608		530 0197 32
			K9K 608		530 0607 30
					531 0547 10
					531 0906 10
			; A/C		529 0009 10
		; A/C		529 0165 10	
				534 0269 10	
		# F-550213.11 F-550213/.02/.08/.09		535 0102 10	
				544 0090 10	
				544 0090 20	
		; A/C		FB 6PK1200	
				538 0095 10	
		1x		428 0198 10	
		FAG	right		821 0952 10
			left		821 0953 10
			;		713 6308 40
			14 "		713 6309 00
			72 mm		713 6309 00
;			713 6309 00		
15 16 "			713 6309 00		
83 mm			713 6309 00		
			814 0182 10		
; ISTANDARD			818 0208 10		
right			825 0339 10		
left			825 0341 10		
↔			840 0375 10		
right		840 1120 10			
left		840 1121 10			
1.5 dCi (FW0F) K9K 806; (76kW)	02.08-	LUK	incl. ; incl.		600 0197 00
					623 3553 33
			incl.		415 0400 10
					530 0197 10
					530 0197 31
					531 0547 10
					529 0009 10
			; A/C		532 0354 10
			; A/C		534 0269 10
			; A/C		532 0354 10
				534 0269 10	
		# F-550213.11 F-550213/.02/.08/.09		535 0102 10	
		11.10→		544 0090 10	
		11.10→		544 0090 20	
				FB 6PK1200	
				538 0047 10	
		FAG	right		821 0952 10
			left		821 0953 10
			;		713 6308 40
			14 "		713 6309 00
			72 mm		713 6309 00
			;		713 6309 00
			15 16 "		713 6309 00
83 mm			713 6309 00		
			814 0182 10		
; ISTANDARD			818 0208 10		
right			825 0339 10		
left			825 0341 10		
↔			840 0375 10		
right		840 1120 10			
left		840 1121 10			



			SCHAEFFLER
--	--	--	-------------------

RENAULT

KANGOO II (FW/KW)





























































































































1.5 dCi (FW0F) K9K 806; (76kW)	02.08-	FAG	right		825 0339 10	
			left		825 0341 10	
1.5 dCi 110 (FW0C, FW0H) K9K 804; K9K 816; (80kW)	09.10-	LUK	incl. ☉; incl. 		600 0197 00	
			incl. 		415 0400 10	
		INA				530 0197 10
						530 0197 31
			K9K 836			531 0547 10
			 ; A/C			529 0009 10
			 ;  A/C			
			 ; A/C ; K9K 804			532 0354 10
			 ; K9K 836; A/C			534 0269 10
			# F-550213.11 F-550213/.02/.08/.09			535 0102 10
			11.10→			544 0090 10
			11.10→			544 0090 20
						FB 6PK1200
						538 0047 10
			1x; K9K 816			428 0198 10
			FAG	right		821 0952 10
left		821 0953 10				
 ; 		713 6308 40				
 14"						
 72 mm						
 ; 		713 6309 00				
 15 16"						
 83 mm						
		814 0182 10				
 ; ISTANDARD		818 0208 10				
right		825 0339 10				
left		825 0341 10				
↔		840 0375 10				
right		840 1120 10				
left		840 1121 10				
1.5 dCi 110 (FW06, FW12) K9K 636; K9K 646; K9K 647; K9K 648; (81kW)	09.13-	LUK	G6;  6DCT250 (DC4)	GearBOX	462 0205 10	
			G6		600 0197 00	
		incl. ☉; incl. 				
		G6		623 3553 33		
		G6		415 0400 10		
		incl. 				
		INA				530 0607 10
						530 0607 30
						531 0906 10
			# F-550213.11 F-550213/.02/.08/.09			535 0102 10
			# F-552973.XX F-550181.XX F-557755.XX			535 0105 10
			# F-550883.XX			535 0154 10
						538 0095 10
			1x		428 0198 10	
			FAG	right		821 0952 10
				left		821 0953 10
 ; 				713 6308 40		
 14"						
 72 mm						
 ; 				713 6309 00		
 15 16"						
 83 mm						
		814 0182 10				
 ; ISTANDARD		818 0208 10				
right		825 0339 10				
left		825 0341 10				
↔		840 0375 10				
right		840 1120 10				
left		840 1121 10				
1.6 (FW00, FW0E, FW0N, FW0P, FW0Y) K7M 750; (64kW)	02.08-	LUK	JR5.168 JH3.170		620 3119 33	
			→11.09		530 0490 10	
		11.09→		530 0604 10		



			SCHAEFFLER
--	---	--	-------------------

RENAULT

KANGOO II (FW/KW)

1.6 (FW00, FW0E, FW0N, FW0P, FW0Y)  K7M 750; (64kW)	02.08-		→11.09		530 0191 31	
			11.09→		530 0604 30	
			→11.09		531 0818 10	
			11.09→		531 0876 10	
					FB 4PK725	
			→11.09		538 0021 10	
			11.09→		538 0375 10	
				428 0124 10		
		FAG		 right		821 0952 10
				 left		821 0953 10
				 ;  		Set 713 6308 40
				 14 "		
				 72 mm		
				 ;  		Set 713 6309 00
				 15 16 "		
				 83 mm		
						814 0182 10
				 ; I STANDARD		818 0208 10
 right				825 0339 10		
 left		825 0341 10				
 ↔		840 0375 10				
 right		840 1120 10				
 left		840 1121 10				
1.6 16V Flex  K4M 834; (72kW)	02.08-		 JR5		620 3119 09	
			 JR5.153 JR5.172		620 3119 33	
			 JR5 ; HD		622 3103 09	
			 JR5.153 JR5.172 ; HD		622 3103 33	
					530 0640 10	
					530 0640 30	
					531 0409 30	
					532 0774 10	
					529 0009 10	
					532 0678 10	
					534 0269 10	
		 # F-552973.XX F-550181.XX F-557755.XX		535 0105 10		
				544 0090 10		
				544 0090 20		
				FB 6PK1200		
				538 0375 10		
		16x		420 0099 10		
		 12 mm				
		16x		422 0009 10		
		FAG		 right		821 0952 10
 left				821 0953 10		
 ;  				Set 713 6308 40		
 14 "						
 72 mm						
 ;  				Set 713 6309 00		
 15 16 "						
 83 mm						
				814 0182 10		
 ; I STANDARD				818 0208 10		
 right				825 0339 10		
 left		825 0341 10				
 ↔		840 0375 10				
 right		840 1120 10				
 left		840 1121 10				
1.6 16V Flex (FW01, FW0U, FW13, FW03, FW09, FW0W)  K4M 834; K4M 835; K4M 836; (78kW)	02.08-		 JR5		620 3119 09	
			 JR5.153 JR5.172		620 3119 33	
			 JR5 ; HD		622 3103 09	
			 JR5.153 JR5.172 ; HD		622 3103 33	
					530 0640 10	
					530 0640 30	
					531 0409 30	
					532 0774 10	
					529 0009 10	
					532 0678 10	
				534 0269 10		









































			SCHAEFFLER
--	--	--	-------------------

RENAULT

























































KANGOO II (FW/KW)

1.6 16V Flex (FW01, FW0U, FW13, FW03, FW09, FW0V)
 K4M 834; K4M 835; K4M 836; (78kW)

02.08-		## F-552973.XX F-550181.XX F-557755.XX		535 0105 10		
		11.10→; A/C		544 0090 10		
		11.10→; A/C		544 0090 20		
				FB 6PK1200		
				538 0375 10		
		16x		420 0099 10		
		 12 mm				
		16x		422 0009 10		
		FAG		right		821 0952 10
				left		821 0953 10
	 ; 				Set 713 6308 40	
	 14"					
	 72 mm					
	 ; 				Set 713 6309 00	
	 15 16"					
	 83 mm					
					814 0182 10	
	 ; STANDARD				818 0208 10	
				825 0339 10		
				825 0341 10		
 ↔			840 0375 10			
			840 1120 10			
			840 1121 10			

MASTER II Box (FD)

1.9 dCi 80
 F9Q 772; F9Q 774; (60kW)































































































11.01-		G5 ;  PK5.012 PK5.068	GearBOX	462 0155 10		
		→04.07; G5 ;  PK5.366	GearBOX	462 0203 10		
		04.07→; G5 ;  PK5.366	GearBOX	462 0231 10		
		→01.03;  F9Q 772		624 3087 09		
		→01.03;  F9Q 772;  PK5.0##		624 3087 33		
		01.03→;  F9Q 772;  PK5.3##		624 3087 34		
		01.03→;  F9Q 772		624 3312 09		
		 F9Q 774				
		01.03→;  F9Q 772		624 3312 33		
		 F9Q 774				
		 PK5.0##				
		01.03→;  F9Q 772		624 3312 34		
		 F9Q 774				
		 PK5.3##				
						530 0196 10
					530 0196 30	
	 ; 03.02→10.06; A/C				533 0087 20	
	 ; →10.06; A/C				529 0124 10	
	 ; A/C				529 0427 10	
	 ; →10.06; A/C				532 0243 10	
	 ; A/C				534 0142 30	
	 ; A/C				534 0240 10	
	## F-560843.XX F-556602.XX F-229643.XX				535 0030 10	
	## F-234637.XX				535 0048 10	
	 ; A/C				FB 6PK1795	
					538 0392 10	
	1x				OILP 553 0124 10	
	FAG			right ↓ down; →09.07		821 0558 10
				right ↓ down; 09.07→		821 0857 10
				left ↓ down; →09.07		821 0557 10
				left ↓ down; 09.07→		821 0855 10
						Set 713 6307 90
			 84 mm			Set 713 6307 80
			 80 mm			
			101,9 mm			771 0292 30
			left ←			SET 772 0230 30
						818 0206 10
						818 0205 10
			↓ down; →09.07			825 0166 10
		↑ up			825 0167 10	
↑ up				825 0280 10		
↓ down; 09.07→				825 0300 10		
			840 0198 10			



			SCHAEFFLER
--	---	--	-------------------

RENAULT

MASTER II Box (FD)

1.9 dCi 80 F9Q 772; F9Q 774; (60kW)	11.01-	FAG	right		840 0878 10
			left		840 0877 10
2.5 dCi 100 (FD0U, FD0V) G9U 754; (73kW)	10.03-	LUK	G5 ;  PK5.007 PK5.008 PK5.015 PK5.016 PK5.067	GearBOX	462 0202 10
			→04.07; G5 ;  PK5.366 PK5.367	GearBOX	462 0203 10
			04.07→; G5 ;  PK5.366 PK5.367 PK5.370	GearBOX	462 0231 10
			→12.05;  PK5.0##		624 3476 09
			 PK5.3##		624 3476 33
					624 3476 34
					530 0198 10
					531 0548 10
					532 0313 20
			 ; →11.04; -e ; A/C		529 0432 10
			 ; →07.06; A/C ; e ; # OE 6PK1835		529 0436 10
			 ; →07.06		532 0364 20
			 ; 09.10→; A/C		532 0534 10
			 ; 09.10→; A/C e		
			 ; →07.06; A/C		534 0181 10
			 ; →07.06; A/C ; e		
			 ; →07.06; A/C ; -e		534 0317 10
			# F-560843.XX F-556602.XX F-229643.XX		535 0030 10
			# F-238512.XX		535 0081 10
					544 0098 10
			 ; 08.06→;  G9U754; A/C ; PTO		FB 6PK1795
			 ; →07.06; A/C ; e		FB 6PK1835
			 ; 11.04→07.06; A/C ; -e		FB 7PK1103
			 ; →11.04;  G9U754; A/C ; PTO		FB 7PK1145
			 ;  G9U754; A/C ; PTO		FB 7PK1795
					538 0374 10
			16x		420 0063 10
			 11 mm		
			1x; 		428 0185 10
			1x; 		428 0186 10
		FAG	right ↓ down; →09.07		821 0558 10
				right ↓ down; 09.07→	
			left ↓ down; →09.07		821 0557 10
			left ↓ down; 09.07→		821 0855 10
			 ; B0001462→;  15 "		713 6307 90
			 ; B000486→;  15 "		
			 ; B000207→;  15 "		
			 ; B000807→;  15 "		
			 ; B000184→;  15 "		
			 ;  16 "		
			 84 mm		
			 ; →B001461;  15 "		713 6308 00
			 ; →B000485;  15 "		
			 ; →B000206;  15 "		
			 ; →B000806;  15 "		
			 ; →B000183;  15 "		
			 84 mm		
			 ;  16 "		713 6307 80
			 80 mm		
			 ;  15 "		713 6308 10
			 80 mm		
			right		818 0206 10
			left		818 0205 10
			↓ down; →09.07		825 0166 10
			↑ up		825 0167 10
			↑ up		825 0280 10
			↓ down; 09.07→		825 0300 10
					840 0198 10
			right		840 0878 10
			left		840 0877 10
2.5 dCi G9U 650; (74kW)	08.06-	LUK	G5 ; PK5.019 PK5.069	GearBOX	462 0155 10
			G5 ; PK5.007 PK5.008 PK5.015 PK5.016 PK5.066 PK5.067	GearBOX	462 0202 10
			G6 ;  PK6.019 PK6.070		
			→04.07; G5 ;  PK5.366 PK5.367	GearBOX	462 0203 10
			04.07→; G5 ;  PK5.366 PK5.367 PK5.370	GearBOX	462 0231 10
					624 3476 09



			SCHAEFFLER
--	--	--	-------------------





















































RENAULT

MASTER II Box (FD)

2.5 dCi

1 G9U 650; (74kW)

08.06-

	PK5.3##		624 3476 33	
	PF6 PK5.#00 PK6.#00		624 3476 34	
			530 0198 10	
			531 0548 10	
			532 0313 20	
	→03.10; A/C; -e		529 0428 10	
	→07.08; e; A/C; # OE 6PK1835		529 0436 10	
	→03.10; A/C; # OE 7PK1835		529 0437 10	
	→03.10; A/C; e; # OE 7PK1835			
	→03.10		532 0364 20	
	09.10→; A/C		532 0534 10	
	09.10→; A/C e			
	→03.10; A/C		534 0181 10	
	→03.10; A/C; e			
	→03.10; A/C; -e		534 0317 10	
	# F-560843.XX F-556602.XX F-229643.XX		535 0030 10	
	# F-238512.XX		535 0081 10	
			544 0098 10	
	OPTION		544 0110 10	
	→07.08; A/C; e		FB 6PK1835	
	→03.10; A/C; -e		FB 7PK1103	
	A/C		FB 7PK1795	
	→03.10; A/C		FB 7PK1835	
	→03.10; A/C; e			
			538 0374 10	
	16x		420 0063 10	
	11 mm			
	1x; 		428 0185 10	
	1x; 		428 0186 10	
	FAG	right ↓ down; →09.07		821 0558 10
		right ↓ down; 09.07→		821 0857 10
left ↓ down; →09.07			821 0557 10	
left ↓ down; 09.07→			821 0855 10	
; B0001462→; 15 "			713 6307 90	
; B000486→; 15 "				
; B000207→; 15 "				
; B000807→; 15 "				
; B000184→; 15 "				
; 16 "				
84 mm				
→B001461; 15 "			713 6308 00	
→B000485; 15 "				
→B000206; 15 "				
→B000806; 15 "				
→B000183; 15 "				
84 mm				
; 16 "			713 6307 80	
80 mm				
; 15 "			713 6308 10	
80 mm				
right			818 0206 10	
left			818 0205 10	
↓ down; →09.07			825 0166 10	
↑ up 			825 0167 10	
↑ up 		825 0280 10		
↓ down; 09.07→		825 0300 10		
		840 0198 10		
right		840 0878 10		
left		840 0877 10		
LUK	G5; PK5.019 PK5.069	GearBOX	462 0155 10	
	G5; PK5.007 PK5.008 PK5.014 PK5.015	GearBOX	462 0202 10	
	G6; PK6.019 PK6.070			
	G6; PK6.369 PK6.370	GearBOX	462 0231 10	
			624 3476 09	
	PF1 PK5.0## PK6.0##		624 3476 33	
	PK5.3## PK6.3## PF6.0##		624 3476 34	
			530 0198 10	
			531 0548 10	
			532 0313 20	

2.5 dCi 120

1 G9U 720; G9U 724; G9U 750; G9U 754; (84kW)

































































































10.01-



			SCHAEFFLER
--	--	--	-------------------

RENAULT

MASTER II Box (FD)

<p>2.5 dCi 120  G9U 720; G9U 724; G9U 750; G9U 754; (84kW)</p>	<p>10.01-</p>	<p></p>	<p> →11.04;  G9U 750;  A/C</p> <p> →09.07;  A/C; # OE 6PK1835</p> <p> →09.07;  G9U 720 G9U 724; A/C; # OE 6PK1835</p> <p> →09.07</p> <p> 09.10→;  G9U 754; A/C</p> <p> 09.10→;  G9U 754; A/C  A/C</p> <p> →09.07; A/C</p> <p> →09.07; A/C;  A/C</p> <p> →09.07; A/C;  A/C</p> <p> # F-560843.XX F-556602.XX F-229643.XX</p> <p> G9U 720 G9U 724; + ACC</p>	<p> 529 0432 10</p> <p> 529 0436 10</p> <p> 532 0364 20</p> <p> 532 0534 10</p> <p> 534 0181 10</p> <p> 534 0317 10</p> <p> 535 0030 10</p> <p> 544 0098 10</p> <p> 544 0098 10</p> <p> FB 6PK1148</p> <p> FB 6PK1795</p>	<p> FB 6PK1835</p> <p> FB 7PK1103</p> <p> FB 7PK1145</p> <p> FB 7PK1795</p> <p> 538 0374 10</p> <p> 420 0063 10</p> <p> 428 0185 10</p> <p> 428 0186 10</p>
		<p>FAG</p>	<p> right ↓ down; →09.07</p> <p> right ↓ down; 09.07→</p> <p> left ↓ down; →09.07</p> <p> left ↓ down; 09.07→</p> <p> 84 mm</p> <p> 80 mm</p> <p> 101,9 mm</p> <p> right</p> <p> left</p> <p> ↓ down; →09.07</p> <p> ↑ up </p> <p> ↑ up </p> <p> ↓ down; 09.07→</p> <p> right</p> <p> left</p>	<p> 821 0558 10</p> <p> 821 0857 10</p> <p> 821 0557 10</p> <p> 821 0855 10</p> <p> Set 713 6307 90</p> <p> Set 713 6307 80</p> <p> 771 0292 30</p> <p> 818 0206 10</p> <p> 818 0205 10</p> <p> 825 0166 10</p> <p> 825 0167 10</p> <p> 825 0280 10</p> <p> 825 0300 10</p> <p> 840 0198 10</p> <p> 840 0878 10</p> <p> 840 0877 10</p>	
<p>2.5 dCi  G9U 650; (88kW)</p>	<p>08.06-</p>	<p></p> <p></p>	<p> PF6</p>	<p> 624 3476 09</p> <p> 624 3476 34</p> <p> 530 0198 10</p> <p> 531 0548 10</p> <p> 532 0313 20</p> <p> 529 0428 10</p> <p> 529 0437 10</p> <p> 532 0364 20</p> <p> 532 0534 10</p> <p> 534 0181 10</p> <p> 534 0317 10</p> <p> 535 0030 10</p> <p> 535 0081 10</p> <p> 544 0098 10</p> <p> 544 0110 10</p> <p> FB 7PK1795</p> <p> FB 7PK1835</p> <p> 538 0374 10</p>	



			SCHAEFFLER
--	---	--	-------------------





























































RENAULT

MASTER II Box (FD)

2.5 dCi
 G9U 650; (88kW)

08.06-







































16x		420 0063 10
 11 mm		428 0185 10
1x; 		428 0186 10
1x; 		821 0558 10
 right ↓ down; →09.07		821 0857 10
 right ↓ down; 09.07→		821 0557 10
 left ↓ down; →09.07		821 0855 10
 left ↓ down; 09.07→		821 0855 10
 ; B0001462→;  15"	 Set	713 6307 90
 ; B000486→;  15"		
 ; B000207→;  15"		
 ; B000807→;  15"		
 ; B000184→;  15"		
 ;  16"		
 84 mm		
 ; →B001461;  15"	 Set	713 6308 00
 ; →B000485;  15"		
 ; →B000206;  15"		
 ; →B000806;  15"		
 ; →B000183;  15"		
 84 mm		
 ;  16"	 Set	713 6307 80
 80 mm		
 ;  15"	 Set	713 6308 10
 80 mm		
right		818 0206 10
left		818 0205 10
↓ down; →09.07		825 0166 10
↑ up 		825 0167 10
↑ up 		825 0280 10
↓ down; 09.07→		825 0300 10
		840 0198 10
right		840 0878 10
left		840 0877 10

2.5 dCi
 G9U 632; (107kW)

08.06-







































































































































		624 3476 09
PF6.0##		624 3476 34
		530 0198 10
		531 0548 10
		532 0313 20
 ; →01.10; A/C;  		529 0428 10
 ; →01.10; A/C; # OE 7PK1835		529 0437 10
 ; →10.10; A/C;  ; # OE 7PK1835		
 ; →10.10		532 0364 20
 ; 09.10→; A/C		532 0534 10
 ; 09.10→; A/C 		
 ; →01.10; A/C		534 0181 10
 ; →01.10; A/C; 		534 0317 10
 ; →01.10; A/C; 		535 0081 10
# F-238512.XX		544 0098 10
		FB 7PK1795
 ; A/C		FB 7PK1835
 ; →01.10; A/C		
 ; →01.10; A/C; 		
		538 0374 10
16x		420 0063 10
11 mm		
1x;		428 0185 10
1x;		428 0186 10
right ↓ down; →09.07		821 0558 10
right ↓ down; 09.07→		821 0857 10
left ↓ down; →09.07		821 0557 10
left ↓ down; 09.07→		821 0855 10
; B0001462→; 15"	Set	713 6307 90
; B000486→; 15"		
; B000207→; 15"		
; B000807→; 15"		
; B000184→; 15"		
; 16"		
84 mm		



			SCHAEFFLER
--	--	--	-------------------

RENAULT

MASTER II Box (FD)

2.5 dCi G9U 632; (107kW)	08.06-	FAG 	 ; →B001461;  15 "	 Set	713 6308 00			
			 ; →B000485;  15 "					
			 ; →B000206;  15 "					
			 ; →B000806;  15 "					
			 ; →B000183;  15 "					
			 84 mm					
			 ;  16 "					
			 80 mm					
			 ;  15 "					
			 80 mm					
			 right				818 0206 10	
			 left				818 0205 10	
			 ↓ down; →09.07				825 0166 10	
			 ↑ up 				825 0167 10	
			 ↑ up 				825 0280 10	
			 ↓ down; 09.07→				825 0300 10	
							840 0198 10	
			 right				840 0878 10	
 left		840 0877 10						
3.0 dCi 120 ZD3 600; (85kW)	06.05-	LUK 	 # F-228751.XX		624 3476 34			
			 ;  BM Master Pro T35, T55, T65				535 0053 10	
			 right ↓ down; →09.07				FB 7PK1642	
			 right ↓ down; 09.07→				821 0558 10	
			 left ↓ down; →09.07				821 0857 10	
			 left ↓ down; 09.07→				821 0557 10	
			 ; B0001462→;  15 "			 Set	821 0855 10	
			 ; B000486→;  15 "					
			 ; B000207→;  15 "					
			 ; B000807→;  15 "					
			 ; B000184→;  15 "					
			 ;  16 "					
			 84 mm					
			 ; →B001461;  15 "				 Set	713 6307 90
			 ; →B000485;  15 "					
			 ; →B000206;  15 "					
			 ; →B000806;  15 "					
			 ; →B000183;  15 "					
			 84 mm					
			 ;  16 "					
			 80 mm					
			 ;  15 "			 Set		713 6308 00
			 80 mm					
			 right					713 6307 80
			 left					713 6308 10
			 ↓ down; →09.07					818 0206 10
			 ↑ up 					818 0205 10
			 ↑ up 					825 0166 10
			 ↓ down; 09.07→					825 0167 10
								825 0280 10
 right		825 0300 10						
 left		840 0198 10						
 right		840 0878 10						
 left		840 0877 10						
3.0 dCi 140 (HD0S, FD0S, HD1S) ZD3 202; (100kW)	10.03-	LUK 	 # F-228751.XX		624 3476 34			
			 ;  BM Master Pro T35, T55, T65				535 0053 10	
			 right ↓ down; →09.07				FB 7PK1920	
			 right ↓ down; 09.07→				538 0384 10	
			 left ↓ down; →09.07				821 0558 10	
			 left ↓ down; 09.07→				821 0857 10	
			 ; B0001462→;  15 "			 Set	821 0557 10	
			 ; B000486→;  15 "					
			 ; B000207→;  15 "					
			 ; B000807→;  15 "					
			; B000184→; 15 "					
			; 16 "					
			84 mm					
			; →B001461; 15 "				Set	713 6307 90
			; →B000485; 15 "					
			; →B000206; 15 "					
			; →B000806; 15 "					
			; →B000183; 15 "					
			84 mm					
			; 16 "					
			80 mm					
			; 15 "			Set		713 6308 00
			80 mm					
			right					713 6307 80
			left					713 6308 10
			↓ down; →09.07					818 0206 10
			↑ up					818 0205 10
			↑ up					825 0166 10
			↓ down; 09.07→					825 0167 10
								825 0280 10
right		825 0300 10						
left		840 0198 10						
right		840 0878 10						
left		840 0877 10						



			SCHAEFFLER
--	--	--	-------------------

RENAULT

MASTER II Box (FD)

3.0 dCi 140 (HD0S, FD0S, HD1S)
 ZD3 202; (100kW)

10.03-

FAG

→B001461; 15"
 →B000485; 15"
 →B000206; 15"
 →B000806; 15"
 →B000183; 15"

 713 6308 00

84 mm

16"

 713 6307 80

80 mm

15"

 713 6308 10

80 mm

right

 818 0206 10

left

 818 0205 10

↓ down; →09.07

 825 0166 10

↑ up

 825 0167 10

↑ up

 825 0280 10

↓ down; 09.07→

 825 0300 10

right

 840 0198 10

left

 840 0878 10

 840 0877 10

 628 3183 00

3.0 dCi 160

ZD3 A 604; (115kW)

06.05-

LUK



F-228751.XX

 535 0053 10

BM Master Pro T35, T55, T65

 FB 7PK1642

FAG

right ↓ down; →09.07

 821 0558 10

right ↓ down; 09.07→

 821 0857 10

left ↓ down; →09.07

 821 0557 10

left ↓ down; 09.07→

 821 0855 10

→B0001462; 15"

 713 6307 90

→B000486; 15"

→B000207; 15"

→B000807; 15"

→B000184; 15"

16"

84 mm

→B001461; 15"

 713 6308 00

→B000485; 15"

→B000206; 15"

→B000806; 15"

→B000183; 15"

84 mm

16"

 713 6307 80

80 mm

15"

 713 6308 10

right

 818 0206 10

left

 818 0205 10

↓ down; →09.07

 825 0166 10

↑ up

 825 0167 10

↑ up

 825 0280 10

↓ down; 09.07→

 825 0300 10

right

 840 0198 10

left

 840 0878 10

 840 0877 10

MASTER II Bus (JD)

1.9 dCi 80

F9Q 772; F9Q 774; (60kW)

11.01-

LUK

G5; PK5.012

 GearBOX 462 0155 10

→04.07; G5; PK5.366

 GearBOX 462 0203 10

04.07→; G5; PK5.366

 GearBOX 462 0231 10

→01.03; F9Q 772

 624 3087 09

→01.03; F9Q 772; PK5.0##

 624 3087 33

01.03→; F9Q 772; PK5.3##

 624 3087 34

01.03→; F9Q 772

 624 3312 09

F9Q 774

 624 3312 33

01.03→; F9Q 772

 624 3312 33

F9Q 774

PK5.0##

01.03→; F9Q 772

 624 3312 34

F9Q 774

PK5.3##



			SCHAEFFLER
--	--	--	-------------------























































RENAULT

MASTER II Bus (JD)

1.9 dCi 80
 F9Q 772; F9Q 774; (60kW)

11.01-



























































		530 0196 10
		530 0196 30
		533 0087 20
 ; 03.02 → 10.06; A/C		529 0124 10
 ; → 10.06; A/C		529 0427 10
 ; A/C		532 0243 10
 ; → 10.06; A/C		534 0142 30
 ; A/C		534 0240 10
Ⓜ# F-560843.XX F-556602.XX F-229643.XX		535 0030 10
Ⓜ# F-234637.XX		535 0048 10
 ; A/C		FB 6PK1795
		538 0392 10
1x		OILP 553 0124 10
FAG  right ↓ down; → 09.07		821 0558 10
 right ↓ down; 09.07 →		821 0857 10
 left ↓ down; → 09.07		821 0557 10
 left ↓ down; 09.07 →		821 0855 10
		Set 713 6307 90
 84 mm		Set 713 6307 80
 80 mm		771 0292 30
 101,9 mm		
 right		818 0206 10
 left		818 0205 10
 ↓ down; → 09.07		825 0166 10
 ↑ up 		825 0167 10
 ↑ up 		825 0280 10
 ↓ down; 09.07 →		825 0300 10
		840 0198 10
 right		840 0878 10
 left		840 0877 10

2.5 dCi 100 (JDCV)
 G9U 754; (73kW)

10.03-



		624 3476 09
 PK5.0## PK6.0##		624 3476 33
 PK5.3## PK6.3##		624 3476 34
		530 0198 10
		531 0548 10
		532 0313 20
 ; 09.06 → 01.10; A/C; -e		529 0428 10
 ; 09.06 → 01.10; A/C; # OE 7PK1835		529 0437 10
 ; 09.06 → 10.10; A/C; e; # OE 7PK1835		
 ; 09.06 → 09.10		532 0364 20
 ; 09.10 →; A/C		532 0534 10
 ; 09.10 →; A/C e		534 0181 10
 ; 09.06 → 01.10; A/C		534 0317 10
 ; 09.06 → 01.10; A/C; e		535 0030 10
Ⓜ# F-560843.XX F-556602.XX F-229643.XX		535 0081 10
Ⓜ# F-238512.XX		544 0098 10
 ; OPTION		544 0110 10
 ; 08.06 →;  G9U754; A/C; PTO		FB 6PK1795
 ; → 11.04;  G9U754; A/C; PTO		FB 7PK1145
 ; A/C; PTO;  G9U754		FB 7PK1795
 ; 09.06 → 01.10; A/C		FB 7PK1835
 ; 09.06 → 01.10; A/C; e		538 0374 10
16x		420 0063 10
 11 mm		
1x; 		428 0185 10
1x; 		428 0186 10
FAG  right ↓ down; → 09.07		821 0558 10
 right ↓ down; 09.07 →		821 0857 10
 left ↓ down; → 09.07		821 0557 10
 left ↓ down; 09.07 →		821 0855 10



			SCHAEFFLER
--	--	--	-------------------

RENAULT

MASTER II Bus (JD)











































2.5 dCi 100 (JDCV) G9U 754; (73kW)	10.03-	FAG	B0001462→; 15"	Set	713 6307 90	
			B000486→; 15"			
			B000207→; 15"			
			B000807→; 15"			
			B000184→; 15"			
			16"			
			84 mm			
			→B001461; 15"	Set	713 6308 00	
			→B000485; 15"			
			→B000206; 15"			
			→B000806; 15"			
			→B000183; 15"			
			84 mm			
			16"	Set	713 6307 80	
			80 mm			
			15"	Set	713 6308 10	
			80 mm			
			101,9 mm		771 0292 30	
			right		818 0206 10	
			left		818 0205 10	
↓ down; →09.07		825 0166 10				
↑ up		825 0167 10				
↑ up		825 0280 10				
↓ down; 09.07→		825 0300 10				
		840 0198 10				
right		840 0878 10				
left		840 0877 10				
2.5 dCi G9U 650; (74kW)	08.06-	LUK	G5 ; PK5.007 PK5.008 PK5.015 PK5.016 PK5.067	GearBOX	462 0202 10	
			→04.07; G5 ; PK5.366 PK5.367	GearBOX	462 0203 10	
			04.07→; G5 ; PK5.366 PK5.367	GearBOX	462 0231 10	
			G6 ; PK6.369 PK6.370			
					624 3476 34	
					530 0198 10	
					531 0548 10	
					532 0313 20	
					529 0428 10	
					529 0437 10	
					532 0364 20	
					532 0534 10	
					534 0181 10	
					534 0317 10	
					535 0030 10	
					535 0081 10	
					544 0098 10	
					544 0110 10	
					FB 7PK1113	
					FB 7PK1795	
					FB 7PK1835	
					538 0374 10	
					420 0063 10	
			16x			
			11 mm			
			1x;		428 0185 10	
			1x;		428 0186 10	
			FAG	right ↓ down; →09.07		821 0558 10
				right ↓ down; 09.07→		821 0857 10
				left ↓ down; →09.07		821 0557 10
left ↓ down; 09.07→		821 0855 10				



			SCHAEFFLER
--	--	--	-------------------

RENAULT

MASTER II Bus (JD)





























































































































2.5 dCi G9U 650; (74kW)	08.06-	FAG	B0001462 →; 15"  713 6307 90
			B000486 →; 15"
			B000207 →; 15"
			B000807 →; 15"
			B000184 →; 15"
			16"
			84 mm
			→B001461; 15"  713 6308 00
			→B000485; 15"
			→B000206; 15"
			→B000806; 15"
			→B000183; 15"
			84 mm
			16"  713 6307 80
			80 mm
			15"  713 6308 10
			80 mm
			right  818 0206 10
			left  818 0205 10
			↓ down; →09.07  825 0166 10
↑ up  825 0167 10			
↑ up  825 0280 10			
↓ down; 09.07 →  825 0300 10			
right  840 0198 10			
left  840 0878 10			
left  840 0877 10			
2.5 dCi 120 G9U 720; G9U 750; G9U 754; (84kW)	10.01-	LUK	G5 ; PK5.007 PK5.008 PK5.014 PK5.015 GearBOX 462 0202 10
			→04.07; G5 ; PK5.366 PK5.367 GearBOX 462 0203 10
			04.07 →; G5 ; PK5.366 PK5.367 GearBOX 462 0231 10
			G6 ; PK6.369 PK6.370
			PK5.000 PK6.000  624 3476 09
			PK5.3## PK6.3##  624 3476 33
			PK5.3## PK6.3##  624 3476 34
			
			 530 0198 10
			 531 0548 10
			 532 0313 20
			→11.04; G9U 750; A/C  529 0432 10
			→12.06; A/C; # OE 6PK1835  529 0436 10
			→12.06; G9U 720; A/C; # OE 6PK1835
			→09.10; G9U 754  532 0364 20
			G9U 720
			09.10 →; G9U 754; A/C  532 0534 10
			09.10 →; G9U 754; A/C
			→12.06; A/C  534 0181 10
			→12.06; A/C;
			→12.06; A/C;  534 0317 10
			# F-560843.XX F-556602.XX F-229643.XX  535 0030 10
			G9U 720; + ACC  544 0094 10
			G9U 720; + ACC  544 0098 10
			G9U 720; + ACC  544 0110 10
			OPTION
			08.06 →; G9U720; A/C; PTO  FB 6PK1148
			08.06 →; G9U754; A/C; PTO  FB 6PK1795
			G9U720; A/C; PTO
			G9U720; A/C; PTO
			→12.06; G9T 720; A/C  FB 6PK1835
			→12.06; G9T 720; A/C;
			A/C; PTO; 11.04 →; G9U754  FB 7PK1103
			→11.04; G9U754; A/C; PTO  FB 7PK1145
			09.03 →; A/C; PTO; G9U754  FB 7PK1795
			16x  538 0374 10
			11 mm  420 0063 10
			1x;  428 0185 10
			1x;  428 0186 10
			FAG
right ↓ down; 09.07 →  821 0857 10			
left ↓ down; →09.07  821 0557 10			
left ↓ down; 09.07 →  821 0855 10			



			<p>SCHAEFFLER</p>
--	--	--	--------------------------

RENAULT

MASTER II Bus (JD)





















<p>2.5 dCi 120 G9U 720; G9U 750; G9U 754; (84kW)</p>	<p>10.01-</p>	<p>FAG</p>	<p>  Set 713 6307 90  84 mm  Set 713 6307 80  80 mm  101,9 mm  right  left  ↓ down; →09.07  ↑ up  ↑ up  ↓ down; 09.07→  right  left </p>	<p>  Set 713 6307 90  Set 713 6307 80  771 0292 30  818 0206 10  818 0205 10  825 0166 10  825 0167 10  825 0280 10  825 0300 10  840 0198 10  840 0878 10  840 0877 10 </p>
<p>2.5 dCi G9U 650; (88kW)</p>	<p>08.06-</p>	<p>LUK</p>	<p>  PF6  INA  INA  INA  →01.10; A/C; -e  →01.10; A/C; # OE 7PK1835  →10.10; A/C; e; # OE 7PK1835  →09.10; A/C  →09.10; A/C e  09.10→; A/C  09.10→; A/C e  →01.10; A/C  →01.10; A/C; e  →01.10; A/C; -e  # F-560843.XX F-556602.XX F-229643.XX  # F-238512.XX  OPTION  →01.10; G9U 750; A/C; -e  A/C; PTO; # OE 8200833558  A/C  →01.10; A/C  →01.10; A/C; e  16x  11 mm  1x;   1x;  </p>	<p>  624 3476 09  624 3476 34  530 0198 10  531 0548 10  532 0313 20  529 0428 10  529 0437 10  532 0364 20  532 0534 10  534 0181 10  534 0317 10  535 0030 10  535 0081 10  544 0098 10  544 0110 10  FB 7PK1103  FB 7PK1795  FB 7PK1835  538 0374 10  420 0063 10  428 0185 10  428 0186 10  821 0558 10  821 0857 10  821 0557 10  821 0855 10  Set 713 6307 90  Set 713 6308 00  Set 713 6307 80  Set 713 6308 10  818 0206 10  818 0205 10  825 0166 10  825 0167 10 </p>
		<p>FAG</p>	<p>  right ↓ down; →09.07  right ↓ down; 09.07→  left ↓ down; →09.07  left ↓ down; 09.07→  B0001462→; 15"  B000486→; 15"  B000207→; 15"  B000807→; 15"  B000184→; 15"  16"  84 mm  →B001461; 15"  →B000485; 15"  →B000206; 15"  →B000806; 15"  →B000183; 15"  84 mm  16"  80 mm  15"  80 mm  right  left  ↓ down; →09.07  ↑ up </p>	<p>  821 0558 10  821 0857 10  821 0557 10  821 0855 10  Set 713 6307 90  Set 713 6308 00  Set 713 6307 80  Set 713 6308 10  818 0206 10  818 0205 10  825 0166 10  825 0167 10 </p>

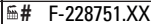

			SCHAEFFLER
--	---	--	-------------------

RENAULT

MASTER II Bus (JD)

2.5 dCi G9U 650; (88kW)	08.06-	FAG	 ↑ up ⇨		825 0280 10
			 ↓ down; 09.07→		825 0300 10
2.5 dCi G9U 632; (107kW)	08.06-	LUK	 right		840 0198 10
			 left		840 0878 10
2.5 dCi G9U 632; (107kW)	08.06-		 PF6		840 0877 10
					624 3476 09
3.0 dCi 140 (JD0T) ZD3 200; ZD3 202; (100kW)	10.03-	LUK	 # F-228751.XX		624 3476 34
					535 0053 10
3.0 dCi 140 (JD0T) ZD3 200; ZD3 202; (100kW)	10.03-				538 0384 10
					821 0558 10
3.0 dCi 140 (JD0T) ZD3 200; ZD3 202; (100kW)	10.03-	FAG	 right ↓ down; →09.07		821 0558 10
					821 0558 10





































			<p>SCHAEFFLER</p>
--	--	--	--------------------------

RENAULT

MASTER II Bus (JD)

3.0 dCi 140 (JD0T)
 ZD3 200; ZD3 202; (100kW)































































10.03-

FAG	right ↓ down; 09.07 →		821 0857 10
	left ↓ down; →09.07		821 0557 10
	left ↓ down; 09.07 →		821 0855 10
	; B0001462 →;  15"		713 6307 90
	; B000486 →;  15"		
	; B000207 →;  15"		
	; B000807 →;  15"		
	; B000184 →;  15"		
	;  16"		
	 84 mm		
	; →B001461;  15"		713 6308 00
	; →B000485;  15"		
	; →B000206;  15"		
	; →B000806;  15"		
	; →B000183;  15"		
	 84 mm		
	;  16"		713 6307 80
	 80 mm		
	;  15"		713 6308 10
	 80 mm		
	right		818 0206 10
	left		818 0205 10
	↓ down; →09.07		825 0166 10
	↑ up 		825 0167 10
	↑ up 		825 0280 10
	↓ down; 09.07 →		825 0300 10
			840 0198 10
	right		840 0878 10
	left		840 0877 10

MASTER II Platform/Chassis (ED/HD/UD)

2.5 dCi 100 (ED4V, ED8V)
 G9U 754; (73kW)

10.03-

LUK	G5 ;  PK5.016 PK5.066 PK5.067	GearBOX	462 0202 10
	→04.07; G5 ;  PK5.366 PK5.367	GearBOX	462 0203 10
	G6 ;  PK6.366		
	04.07 →; G5 ;  PK5.366 PK5.367	GearBOX	462 0231 10
			624 3476 09
	→12.05;  PK5.0##		624 3476 33
	 PK5.3##		624 3476 34
TNA A			530 0198 10
			531 0548 10
			532 0313 20
	 ; →11.04;  ; A/C		529 0432 10
	 ; →07.08;  ; A/C ; # OE 6PK1835		529 0436 10
	 ; →05.10		532 0364 20
	 ; 09.10 →; A/C		532 0534 10
	 ; 09.10 →; A/C 		
	 ; →05.10; A/C		534 0181 10
	 ; →05.10; A/C ; 		
	 ; →05.10; A/C ; 		534 0317 10
	 # F-560843.XX F-556602.XX F-229643.XX		535 0030 10
	 # F-238512.XX		535 0081 10
			544 0098 10
	 ; 08.06 →;  G9U754; A/C ; PTO		FB 6PK1795
	 ; →07.08; A/C ; 		FB 6PK1835
	 ; 11.04 →05.10; A/C ; 		FB 7PK1103
	 ; →11.04;  G9U754; A/C ; PTO		FB 7PK1145
	 ;  G9U754; A/C ; PTO		FB 7PK1795
			538 0374 10
	16x		420 0063 10
	 11 mm		
	1x; 		428 0185 10
	1x; 		428 0186 10
FAG	right ↓ down; →09.07		821 0558 10
	right ↓ down; 09.07 →		821 0857 10
	left ↓ down; →09.07		821 0557 10
	left ↓ down; 09.07 →		821 0855 10





RENAULT

MASTER II Platform/Chassis (ED/HD/UD)















































































































































<p>2.5 dCi 100 (ED4V, ED8V) 10.03- G9U 754; (73kW)</p>	<p>10.03-</p>	<p>FAG</p>	<p> B; B0001462→; 15" B; B000486→; 15" B; B000207→; 15" B; B000807→; 15" B; B000184→; 15" B; 16" 84 mm B; →B001461; 15" B; →B000485; 15" B; →B000206; 15" B; →B000806; 15" B; →B000183; 15" 84 mm B; 16" 80 mm B; 15" 80 mm right left ↓ down; →09.07 ↑ up ↑ up ↓ down; 09.07→ right left </p>	<p> Set 713 6307 90 Set 713 6308 00 Set 713 6307 80 Set 713 6308 10 818 0206 10 818 0205 10 825 0166 10 825 0167 10 825 0280 10 825 0300 10 840 0198 10 840 0878 10 840 0877 10 </p>	
<p>2.5 dCi 08.06- G9U 650; (74kW)</p>	<p>08.06-</p>	<p>LUK</p>	<p> G5; PK5.019 PK5.069 G6; PK6.007 PK6.008 PK6.015 G5; PK5.007 PK5.008 PK5.015 PK5.016 PK5.020 PK5.066 PK5.067 PK5.070 G6; PK6.017 PK6.019 PK6.070 →04.07; G5; PK5.366 PK5.367 PK5.369 PK5.370 04.07→; G5; PK5.366 PK5.367 PK5.369 PK5.370 PK5.3## PF6.0## PK5.0## PK6.0## INA →07.08; A/C; # OE 6PK1835 →01.10 09.10→; A/C 09.10→; A/C →01.10; A/C →01.10; A/C; →01.10; A/C; # F-560843.XX F-556602.XX F-229643.XX # F-238512.XX OPTION →07.08; A/C; →01.10; A/C; A/C A/C 16x 11 mm 1x; 1x; </p>	<p> GearBOX 462 0155 10 GearBOX 462 0202 10 GearBOX 462 0203 10 GearBOX 462 0231 10 624 3476 09 624 3476 33 624 3476 34 530 0198 10 531 0548 10 532 0313 20 529 0436 10 532 0364 20 532 0534 10 534 0181 10 534 0317 10 535 0030 10 535 0081 10 544 0098 10 544 0110 10 FB 6PK1835 FB 7PK1103 FB 7PK1113 FB 7PK1795 538 0374 10 420 0063 10 428 0185 10 428 0186 10 821 0558 10 821 0857 10 821 0557 10 821 0855 10 </p>	<p> FAG right ↓ down; →09.07 right ↓ down; 09.07→ left ↓ down; →09.07 left ↓ down; 09.07→ </p>



			SCHAEFFLER
--	--	--	-------------------

RENAULT

MASTER II Platform/Chassis (ED/HD/UD)

2.5 dCi  G9U 650; (74kW)	08.06-	FAG	 ; B0001462→;  15"		713 6307 90
			 ; B000486→;  15"		
			 ; B000207→;  15"		
			 ; B000807→;  15"		
			 ; B000184→;  15"		
			 ;  16"		
			 84 mm		
			 ; →B001461;  15"		713 6308 00
			 ; →B000485;  15"		
			 ; →B000206;  15"		
			 ; →B000806;  15"		
			 ; →B000183;  15"		
			 84 mm		
			 ;  16"		713 6307 80
			 80 mm		
			 ;  15"		713 6308 10
			 80 mm		
			 right		818 0206 10
			 left		818 0205 10
			 ↓ down; →09.07		825 0166 10
 ↑ up 		825 0167 10			
 ↑ up 		825 0280 10			
 ↓ down; 09.07→		825 0300 10			
		840 0198 10			
 right		840 0878 10			
 left		840 0877 10			
2.5 dCi 120  G9U 720; G9U 724; G9U 750; G9U 754; (84kW)	10.01-	LUK	G5 ;  PK5.019 PK5.069	GearBOX	462 0155 10
			G6 ;  PK6.007 PK6.008 PK6.015		
			G5 ;  PK5.007 PK5.008 PK5.014 PK5.015 PK5.016 PK5.020 PK5.066 PK5.067 PK5.070	GearBOX	462 0202 10
			G6 ;  PK6.017 PK6.019 PK6.070		
			→04.07; G5 ;  PK5.366 PK5.367 PK5.369 PK5.370	GearBOX	462 0203 10
			04.07→; G5 ;  PK5.366 PK5.367 PK5.369 PK5.370	GearBOX	462 0231 10
			G6 ;  PK6.369 PK6.370		
					624 3476 09
					624 3476 33
					624 3476 34
					530 0198 10
					531 0548 10
					532 0313 20
			 ; →11.04;  G9U 750;  ; <i>A/C</i>		529 0432 10
			 ; →05.10;  ; <i>A/C</i> ; # OE 6PK1835		529 0436 10
			 ; →05.10		532 0364 20
			 ; 09.10→;  G9U 754; <i>A/C</i>		532 0534 10
			 ; 09.10→;  G9U 754; <i>A/C</i> 		
			 ; →05.10; <i>A/C</i>		534 0181 10
			 ; →05.10; <i>A/C</i> ; 		534 0317 10
			 # F-560843.XX F-556602.XX F-229643.XX		535 0030 10
			  G9U 720; + ACC		544 0094 10
					544 0098 10
			 ; OPTION		544 0110 10
			 ; 08.06→;  G9U720; <i>A/C</i> ; <i>PTO</i>		FB 6PK1148
			 ; 08.06→;  G9U754; <i>A/C</i> ; <i>PTO</i>		FB 6PK1795
			 ;  G9U720; <i>A/C</i> ; <i>PTO</i>		
			 ;  G9U720; <i>A/C</i> ; <i>PTO</i>		
			 ; →07.08;  G9U 720 G9U 724; <i>A/C</i>		FB 6PK1835
			 ; →07.08;  G9U 750; <i>A/C</i> ; 		
			 ; 11.04→;  G9U754; <i>A/C</i> ; <i>PTO</i>		FB 7PK1103
			 ; →11.04;  G9U754; <i>A/C</i> ; <i>PTO</i>		FB 7PK1145
			 ; 09.03→; <i>A/C</i> ; <i>PTO</i> ;  G9U754		FB 7PK1795
					538 0374 10
			 16x		420 0063 10
 11 mm					
1x; 		428 0185 10			
1x; 		428 0186 10			
FAG  right ↓ down; →09.07		821 0558 10			
 right ↓ down; 09.07→		821 0857 10			





SCHAEFFLER



RENAULT

MASTER II Platform/Chassis (ED/HD/UD)























































<p>2.5 dCi 120 G9U 720; G9U 724; G9U 750; G9U 754; (84kW)</p>	<p>10.01-</p>	<p>FAG</p>	<p>left ↓ down; →09.07 left ↓ down; 09.07→ 84 mm 80 mm 101,9 mm right left ↓ down; →09.07 ↑ up ↑ up ↓ down; 09.07→ right left</p>		<p>821 0557 10 821 0855 10 713 6307 90 713 6307 80 771 0292 30 818 0206 10 818 0205 10 825 0166 10 825 0167 10 825 0280 10 825 0300 10 840 0198 10 840 0878 10 840 0877 10</p>
<p>2.5 dCi G9U 650; (88kW)</p>	<p>08.06-</p>	<p>LUK</p> <p>INA</p>	<p>PF6.0## →01.11; A/C; -e →01.11; A/C; # OE 7PK1835 →10.11; A/C; e; # OE 7PK1835 →01.11 09.10→; A/C 09.10→; A/C e →01.11; A/C →01.11; A/C; e →01.11; A/C; -e F-560843.XX F-556602.XX F-229643.XX F-238512.XX OPTION A/C; PTO; # OE 8200833558 A/C →01.11; A/C →01.11; A/C; e 16x 11 mm 1x 1x</p>		<p>624 3476 09 624 3476 34 530 0198 10 531 0548 10 532 0313 20 529 0428 10 529 0437 10 532 0364 20 532 0534 10 534 0181 10 534 0317 10 535 0030 10 535 0081 10 544 0098 10 544 0110 10 FB 7PK1795 FB 7PK1835 538 0374 10 420 0063 10 428 0185 10 428 0186 10</p>
		<p>FAG</p>	<p>right ↓ down; →09.07 right ↓ down; 09.07→ left ↓ down; →09.07 left ↓ down; 09.07→ B0001462→; 15" B000486→; 15" B000207→; 15" B000807→; 15" B000184→; 15" 16" 84 mm →B001461; 15" →B000485; 15" →B000206; 15" →B000806; 15" →B000183; 15" 84 mm 16" 80 mm 15" 80 mm right left ↓ down; →09.07 ↑ up</p>		<p>821 0558 10 821 0857 10 821 0557 10 821 0855 10 713 6307 90 713 6308 00 713 6307 80 713 6308 10 818 0206 10 818 0205 10 825 0166 10 825 0167 10</p>



			<p>SCHAEFFLER</p>
--	--	--	--------------------------

RENAULT

MASTER II Platform/Chassis (ED/HD/UD)





































































































































<p>2.5 dCi G9U 650; (88kW)</p>	<p>08.06-</p>	<p>FAG</p>	<p>↑ up ↗ ↓ down; 09.07→ right left</p>	<p> 825 0280 10  825 0300 10  840 0198 10  840 0878 10  840 0877 10</p>
<p>2.5 dCi G9U 632; (107kW)</p>	<p>08.06-</p>	<p>LUK INA FAG</p>	<p>PF6.0## →01.10; A/C; -e →01.10; A/C; # OE 7PK1835 →10.10; A/C; e; # OE 7PK1835 →01.10 09.10→; A/C 09.10→; A/C e →01.10; A/C →01.10; A/C; e →01.10; A/C; -e # F-238512.XX OPTION A/C; PTO; # OE 8200833558 A/C →01.10; A/C →01.10; A/C; e 16x 11 mm 1x; ↘ 1x; ↗ right ↓ down; →09.07 right ↓ down; 09.07→ left ↓ down; →09.07 left ↓ down; 09.07→ B0001462→; 15" B000486→; 15" B000207→; 15" B000807→; 15" B000184→; 15" 16" 84 mm →B001461; 15" →B000485; 15" →B000206; 15" →B000806; 15" →B000183; 15" 84 mm 16" 80 mm 15" 80 mm right left ↓ down; →09.07 ↑ up ↗ ↑ up ↗ ↓ down; 09.07→ right left</p>	<p> 624 3476 09  624 3476 34  530 0198 10  531 0548 10  532 0313 20  529 0428 10  529 0437 10  532 0364 20  532 0534 10  534 0181 10  534 0317 10  535 0081 10  544 0098 10  544 0110 10  FB 7PK1795  FB 7PK1835  538 0374 10  420 0063 10  428 0185 10  428 0186 10  821 0558 10  821 0857 10  821 0557 10  821 0855 10  713 6307 90  713 6308 00  713 6307 80  713 6308 10  818 0206 10  818 0205 10  825 0166 10  825 0167 10  825 0280 10  825 0300 10  840 0198 10  840 0878 10  840 0877 10  624 3476 34  535 0053 10  821 0558 10  821 0857 10  821 0557 10  821 0855 10</p>
<p>3.0 dCi 120 ZD3 600; (85kW)</p>	<p>06.05-</p>	<p>LUK INA FAG</p>	<p># F-228751.XX right ↓ down; →09.07 right ↓ down; 09.07→ left ↓ down; →09.07 left ↓ down; 09.07→</p>	<p> 624 3476 34  535 0053 10  821 0558 10  821 0857 10  821 0557 10  821 0855 10</p>



			SCHAEFFLER
--	---	--	-------------------

RENAULT

MASTER II Platform/Chassis (ED/HD/UD)

<p>3.0 dCi 120  ZD3 600; (85kW)</p>	<p>06.05-</p>	<p>FAG</p>	 ; B0001462→;  15"	 Set	<p>713 6307 90</p>																															
			 ; B000486→;  15"																																	
			 ; B000207→;  15"																																	
			 ; B000807→;  15"																																	
			 ; B000184→;  15"																																	
			 ;  16"																																	
			 84 mm																																	
			 ; →B001461;  15"			 Set	<p>713 6308 00</p>																													
			 ; →B000485;  15"																																	
			 ; →B000206;  15"																																	
			 ; →B000806;  15"																																	
			 ; →B000183;  15"																																	
			 84 mm																																	
			 ;  16"																																	
			 80 mm																																	
			 ;  15"					 Set	<p>713 6308 10</p>																											
			 80 mm																																	
			 right								<p>818 0206 10</p>																									
			 left										<p>818 0205 10</p>																							
			 ↓ down; →09.07												<p>825 0166 10</p>																					
 ↑ up 		<p>825 0167 10</p>																																		
 ↑ up 				<p>825 0280 10</p>																																
 ↓ down; 09.07→																<p>825 0300 10</p>																				
																		<p>840 0198 10</p>																		
 right																				<p>840 0878 10</p>																
 left																						<p>840 0877 10</p>														
<p>LUK</p>																								<p>624 3476 34</p>												
							<p>535 0053 10</p>																													
<p># F-228751.XX</p>																										<p>FB 7PK1920</p>										
<p>FAG</p>																												<p>538 0384 10</p>								
 right ↓ down; →09.07																														<p>821 0558 10</p>						
 right ↓ down; 09.07→																																<p>821 0857 10</p>				
 left ↓ down; →09.07																																		<p>821 0557 10</p>		
 left ↓ down; 09.07→																																				<p>821 0855 10</p>
 ; B0001462→;  15"																																				
 ; B000486→;  15"																																				
 ; B000207→;  15"																																				
 ; B000807→;  15"																																				
 ; B000184→;  15"																																				
 ;  16"																																				
 84 mm																																				
 ; →B001461;  15"	 Set	<p>713 6308 00</p>																																		
 ; →B000485;  15"																																				
 ; →B000206;  15"																																				
 ; →B000806;  15"																																				
 ; →B000183;  15"																																				
 84 mm																																				
 ;  16"																																				
 80 mm																																				
 ;  15"			 Set	<p>713 6308 10</p>																																
 80 mm																																				
 right						<p>818 0206 10</p>																														
 left								<p>818 0205 10</p>																												
 ↓ down; →09.07										<p>825 0166 10</p>																										
 ↑ up 												<p>825 0167 10</p>																								
 ↑ up 														<p>825 0280 10</p>																						
 ↓ down; 09.07→																<p>825 0300 10</p>																				
																		<p>840 0198 10</p>																		
 right																				<p>840 0878 10</p>																
 left																						<p>840 0877 10</p>														
<p>LUK</p>																								<p>624 3476 34</p>												
		<p>535 0053 10</p>																																		
<p># F-228751.XX</p>																										<p>821 0558 10</p>										
<p>FAG</p>																												<p>821 0857 10</p>								
 right ↓ down; →09.07																														<p>821 0557 10</p>						
 right ↓ down; 09.07→																																<p>821 0855 10</p>				
 left ↓ down; →09.07																																		<p>821 0855 10</p>		
 left ↓ down; 09.07→																																				<p>821 0855 10</p>



			SCHAEFFLER
--	--	--	-------------------

RENAULT

MASTER II Platform/Chassis (ED/HD/UD)

3.0 dCi 160 ZD3 A 604; (115kW)	06.05-	FAG	; B0001462→; 15"		713 6307 90
			; B000486→; 15"		
			; B000207→; 15"		
			; B000807→; 15"		
			; B000184→; 15"		
			; 16"		
			84 mm		
			; →B001461; 15"		713 6308 00
			; →B000485; 15"		
			; →B000206; 15"		
			; →B000806; 15"		
			; →B000183; 15"		
			84 mm		
			; 16"		713 6307 80
			80 mm		
			; 15"		713 6308 10
			80 mm		
			right		818 0206 10
			left		818 0205 10
			↓ down; →09.07		825 0166 10
↑ up		825 0167 10			
↑ up		825 0280 10			
↓ down; 09.07→		825 0300 10			
		840 0198 10			
right		840 0878 10			
left		840 0877 10			

MASTER III

2.3 dCi 100 FWD (EV0A, EV0B, HV0A, HV0B, UV0A, UV0B, ..) M9T 670; M9T 672; M9T 676; M9T 870; M9T 876; (74kW)	02.10-	LUK	PF6 incl. ; incl. ; SAC		600 0235 00
			PF6 PA0 SAC		626 3049 09
			PF6 SAC		626 3049 33
			incl.		415 0485 10
					529 0317 10
			; ;		529 0353 10
					532 0534 10
					534 0281 10
			# F-236675.XX F-561464.XX		535 0080 10
			# F-552305.XX		535 0153 10
		; ;		FB 7PK1685	
		;		FB 7PK1973	
		; ;			
				538 0397 10	
		16x 12 mm		420 0086 10	
		16x		422 0078 10	
		1x		558 0060 10	
		1x		559 0172 10	
		1x		559 0172 30	
		FAG	right		821 0865 10
			left		821 0868 10
					713 6450 40
			90 mm		
			80 mm		713 6450 50
			↔		818 0482 10
			↔		818 0475 10
			right; 07.10→		825 0333 10
			left		825 0332 10
			right; →07.10		
		↔		840 0394 10	
right		840 1143 10			
left		840 1142 10			
LUK	02.10-	PF6 incl. ; incl. ; SAC		600 0235 00	
		PF6 PA0 SAC		626 3049 09	





SCHAEFFLER



RENAULT

MASTER III

2.3 dCi 100 FWD (FV0A, FV0B, FV0G, FV0K, FV0H)
 M9T 670; M9T 672; M9T 676; M9T 870; M9T 876; (74kW)

02.10-



PF6
SAC

incl.

; BM Master T28
 ; BM Master T33
 ; BM Master T35

; ; A/C

F-236675.XX F-561464.XX

F-552305.XX

; A/C ; PTO

; A/C

; A/C ; PTO

16x

12 mm

16x

1x

1x

1x



right

left

90 mm

80 mm

↔

↔

right; 07.10→

left

right; →07.10

↔

right

left

2.3 dCi 100 RWD (FV0B)
 M9T 690; M9T 890; (74kW)

02.10-



M9T 690 M9T 890 M9T 692

M9T 690 M9T 692 M9T 890

incl.

; A/C

; A/C ;

; ; A/C

90 mm

F-236675.XX F-561464.XX

F-552305.XX

; A/C ; PTO

16x

12 mm

16x

1x

1x

1x



right

left

90 mm

;

90 mm

↔

↔ ;

↔ ;

right; 07.10→

left

right; →07.10

↔

right

left









































			<p>SCHAEFFLER</p>
--	--	--	--------------------------

RENAULT

MASTER III

































2.3 dCi 100 RWD (HV0B, UV0B)
 M9T 690; (74kW)

02.10-

	M9T 690 M9T 692 M9T 890 M9T 690 M9T 692 M9T 890 incl. 	 626 3050 00  415 0490 10
	A/C A/C; 	 529 0352 10
	A/C	 529 0353 10
	M9T	 532 0534 10
	F-236675.XX F-561464.XX	 534 0281 10
	F-552305.XX	 535 0080 10
	A/C	 535 0153 10
	A/C; PTO	 FB 7PK1685
	16x	 FB 7PK1685
	12 mm	 420 0086 10
	16x	 422 0078 10
	1x	  558 0060 10
	1x	  559 0172 10
	1x	  559 0172 30
	right	 821 0865 10
	left	 821 0868 10
	90 mm	  713 6450 40
	90 mm	  713 6450 30
	90 mm	  713 6451 60
	↔	 818 0482 10
	↔; 	 818 0475 10
	right; 07.10→	 825 0333 10
	left	 825 0332 10
	right; →07.10	 840 0394 10
	↔	 840 1143 10
	right	 840 1142 10
	left	 600 0235 00

2.3 dCi 100 FWD (JV0A, JV0B, JV0G, JV0H)
 M9T 670; M9T 672; M9T 676; M9T 870; (74kW)





































































































02.11-

	M9T 670 M9T 676; PF6 incl.  ; SAC	 626 3049 33
	M9T 670 M9T 676; PF6 SAC	 415 0485 10
	M9T 670 M9T 676; PF6 incl. 	 529 0317 10
	BM Master T28	 529 0353 10
	BM Master T30	 532 0534 10
	BM Master T33	 534 0281 10
	BM Master T35	 535 0080 10
	A/C	 535 0153 10
	A/C	 FB 7PK1685
	A/C; PTO	 FB 7PK1973
	16x	 538 0397 10
	12 mm	 420 0086 10
	16x	 422 0078 10
	1x	  558 0060 10
	1x	  559 0172 10
	1x	  559 0172 30
	right	 821 0865 10
	left	 821 0868 10
	90 mm	  713 6450 40
	80 mm	  713 6450 50
	↔	 818 0482 10
	↔	 818 0475 10
	right	 825 0333 10
	left	 825 0332 10
	↔	 840 0394 10



			SCHAEFFLER
--	---	--	-------------------

RENAULT













































































































MASTER III					
2.3 dCi 100 FWD (JV0A, JV0B, JV0G, JV0H) M9T 670; M9T 672; M9T 676; M9T 870; (74kW)	02.11-	FAG	right	 840 1143 10	
			left	 840 1142 10	
	2.3 dCi 110 FWD (EV0R, EV0W, HV0R, HV0W, UV0R, UV0W) M9T 704; M9T 870; (81kW)	09.14-	LUK	PF6	 600 0235 00
				incl.  ; incl.  ; SAC	 626 3049 09
				PF6 PA0	 626 3049 33
				SAC	 415 0485 10
				incl. 	 529 0317 10
				 ; A/C	 529 0353 10
				 ;  ; A/C	 532 0534 10
					 534 0281 10
				 535 0080 10	
 # F-236675.XX F-561464.XX				 535 0153 10	
09.14-		FAG	right	 821 0865 10	
			left	 821 0868 10	
			 90 mm	 713 6450 40	
			 80 mm	 713 6450 50	
				 818 0482 10	
			 ; A/C	 818 0475 10	
			 ;  ; A/C	 825 0333 10	
				 825 0332 10	
				 840 0394 10	
				 840 1143 10	
2.3 dCi 110 FWD (FV0R, FV0W) M9T 704; M9T 870; (81kW)	09.14-	LUK	PF6	 600 0235 00	
			incl.  ; incl.  ; SAC	 626 3049 09	
			PF6 PA0	 626 3049 33	
			SAC	 415 0485 10	
			incl. 	 529 0317 10	
			 ;  BM Master T28/T33/T35; A/C	 529 0353 10	
			 ;  ; A/C	 532 0534 10	
				 534 0281 10	
				 535 0080 10	
			 # F-236675.XX F-561464.XX	 535 0153 10	
2.3 dCi 110 FWD (JV0R, JV0W) M9T 704; M9T 870; (81kW)	09.14-	FAG	right	 821 0865 10	
			left	 821 0868 10	
			 90 mm	 713 6450 40	
			 80 mm	 713 6450 50	
				 818 0482 10	
			 ; A/C	 818 0475 10	
			 ;  ; A/C	 825 0333 10	
				 825 0332 10	
				 840 0394 10	
				 840 1143 10	
2.3 dCi 110 FWD (JV0R, JV0W) M9T 704; M9T 870; (81kW)	09.14-	LUK	M9T 870	 600 0235 00	
			incl.  ; incl.  ; SAC	 626 3049 33	
			M9T 870	 415 0485 10	
			SAC	 529 0317 10	
			incl. 	 529 0353 10	
	 ; A/C	 532 0534 10			
	 ; 07.15-  ; A/C	 534 0281 10			
		 535 0080 10			
	 # F-236675.XX F-561464.XX				



			SCHAEFFLER
--	--	--	-------------------

RENAULT

MASTER III

























































































































2.3 dCi 110 FWD (JV0R, JV0W) M9T 704; M9T 870; (81kW)	09.14-	 FAG	# F-552305.XX 		535 0153 10			
					FB 7PK1685			
			 right		821 0865 10			
			 left		821 0868 10			
			 90 mm		713 6450 40			
			 80 mm		713 6450 50			
			 ↔		818 0482 10			
			 ↔		818 0475 10			
			 right		825 0333 10			
			 left		825 0332 10			
			 ↔		840 0394 10			
			 right		840 1143 10			
			 left		840 1142 10			
			2.3 dCi 125 FWD (EV0C, EV0D, EV0J, HV0C, HV0D, HV0H, ..) M9T 670; M9T 672; M9T 676; M9T 680; M9T 870; M9T 872; M9T 876; M9T 880; (92kW)	02.10-		M9T 670 M9T 676 M9T 870; PF6 incl.  ; incl.  ; SAC		600 0235 00
						M9T 670 M9T 676 M9T 870 SAC		626 3049 09
M9T 670 M9T 676 M9T 870; PF6 SAC		626 3049 33						
M9T 670 M9T 676 M9T 870 incl. 		415 0485 10						
					529 0317 10			
	 ;  ; 				529 0353 10			
					532 0534 10			
					534 0281 10			
	# F-236675.XX F-561464.XX				535 0080 10			
	# F-552305.XX				535 0153 10			
	 ; 				FB 7PK1685			
					FB 7PK1973			
	 ; 				538 0397 10			
	16x  12 mm				420 0086 10			
	16x				422 0078 10			
1x		558 0060 10						
1x		559 0172 10						
1x		559 0172 30						
FAG	 right				821 0865 10			
	 left				821 0868 10			
	 90 mm				713 6450 40			
	 80 mm				713 6450 50			
	 ↔				818 0482 10			
	 ↔				818 0475 10			
	 right; 07.10→				825 0333 10			
	 left		825 0332 10					
	 right; →07.10		840 0394 10					
	 ↔		840 1143 10					
	 left		840 1142 10					
	M9T 670 M9T 676 M9T 870; PF6 incl.  ; incl.  ; SAC		600 0235 00					
	M9T 670 M9T 676 M9T 870 SAC		626 3049 09					
	M9T 670 M9T 676 M9T 870; PF6 SAC		626 3049 33					
	M9T 670 M9T 676 M9T 870 incl. 		415 0485 10					
		 ;  BM Master T28/T33/T35		529 0317 10				
		 ;  ; 		529 0353 10				
				532 0534 10				
				534 0281 10				
		# F-236675.XX F-561464.XX		535 0080 10				
	# F-552305.XX		535 0153 10					
	 ; 		FB 7PK1685					



			SCHAEFFLER
--	---	--	-------------------

RENAULT

MASTER III

2.3 dCi 125 FWD (FV0C, FV0D, FV0G, FV0H, FV0J, FV0K) M9T 670; M9T 672; M9T 676; M9T 680; M9T 870; M9T 872; M9T 876; M9T 880; M9T 882; (92kW)	02.10-		 ; A/C		FB 7PK1973	
			 ; A/C ; PTO			
			16x		538 0397 10	
			 12 mm		420 0086 10	
			16x		422 0078 10	
			1x		558 0060 10	
			1x		559 0172 10	
			1x		559 0172 30	
			FAG	 right		821 0865 10
				 left		821 0868 10
					713 6450 40	
		 90 mm			713 6450 50	
		 80 mm				
		 ↔			818 0482 10	
		 ↔			818 0475 10	
		 right; 07.10→			825 0333 10	
		 left			825 0332 10	
		 right; →07.10				
		 ↔		840 0394 10		
		 right		840 1143 10		
 left		840 1142 10				
2.3 dCi 125 RWD (FV0C, FV0D, FV0H, FV0J, FV0A, FV0K) M9T 686; M9T 690; M9T 692; M9T 696; M9T 698; M9T 890; M9T 896; M9T 898; (92kW)	02.10-		 ZF4 ;  M9T 896		626 3050 00	
			 M9T 896 incl. 		415 0490 10	
			 ; A/C		529 0352 10	
			 ; A/C ; 		529 0353 10	
			 ;  ; A/C		532 0534 10	
					534 0281 10	
			 # F-236675.XX F-561464.XX		535 0080 10	
			 # F-552305.XX		535 0153 10	
					FB 7PK1685	
			 ; PTO		FB 7PK1685	
			16x		420 0086 10	
			 12 mm			
		16x		422 0078 10		
		1x		558 0060 10		
		1x		559 0172 10		
		1x		559 0172 30		
		FAG	 right		821 0865 10	
			 left		821 0868 10	
			 90 mm		713 6450 40	
					713 6450 30	
 90 mm			713 6451 60			
 ↔			818 0482 10			
 ↔ ; 			818 0475 10			
 ↔ ; 			818 0492 10			
 right; 07.10→			825 0333 10			
 left			825 0332 10			
 right; →07.10						
 ↔		840 0394 10				
 right		840 1143 10				
 left		840 1142 10				
	 M9T 686 M9T 690 M9T 692 M9T 698 M9T 890		626 3050 00			
	 M9T 686 M9T 690 M9T 692 M9T 698 M9T 890 incl. 		415 0490 10			
		 ; A/C		529 0352 10		
		 ; A/C ; 		529 0353 10		
		 ;  ; A/C		532 0534 10		
				534 0281 10		
		 # F-236675.XX F-561464.XX		535 0080 10		
		 # F-552305.XX		535 0153 10		
		 ; PTO		FB 7PK1685		



			SCHAEFFLER
--	--	--	-------------------

RENAULT







MASTER III

2.3 dCi 125 RWD (HV0C, HV0D, UV0C, UV0D, UV0H, UV0J, ..)



























M9T 686; M9T 690; M9T 692; M9T 696; M9T 698; M9T 882; M9T 890; M9T 896; M9T 898; (92kW)

02.10-



- 16x  12 mm  420 0086 10
- 16x  422 0078 10
- 1x  558 0060 10
- 1x  559 0172 10
- 1x  559 0172 30













-  right  821 0865 10
-  left  821 0868 10
-  90 mm  713 6450 40
-  90 mm  713 6450 30
-  90 mm  713 6451 60
-  ↔  818 0482 10
-  ↔  818 0475 10
-  ↔  818 0492 10
-  right; 07.10 →  825 0333 10
-  left  825 0332 10
-  right; →07.10  840 0394 10
-  ↔  840 1143 10
-  left  840 1142 10

2.3 dCi 125 FWD (JV0C, JV0D, JV0H, JV0G, JV0J)











































M9T 670; M9T 672; M9T 676; M9T 680; M9T 870; M9T 880; (92kW)

02.11-































-  PF6  600 0235 00
- incl. ○; incl.  SAC  626 3049 33
-  PF6  626 3049 33
-  SAC  626 3049 33
- incl.   415 0485 10



-   BM Master T28  529 0317 10
-   10.12 →;  BM Master T30  529 0317 10
-   BM Master T33  529 0317 10
-   BM Master T35  529 0317 10
-   08.12 →;  BM Master T38  529 0317 10
-   A/C  529 0353 10
-     532 0534 10
-     534 0281 10
-  # F-236675.XX  F-561464.XX  535 0080 10
-  # F-552305.XX  535 0153 10
-   A/C; PTO  FB 7PK1685
-   A/C  FB 7PK1973
-   A/C; PTO  538 0397 10



- 16x  12 mm  420 0086 10
- 16x  422 0078 10
- 1x  558 0060 10
- 1x  559 0172 10
- 1x  559 0172 30
-  right  821 0865 10
-  left  821 0868 10
-  90 mm  713 6450 40
-  80 mm  713 6450 50
-  ↔  818 0482 10
-  ↔  818 0475 10
-  right  825 0333 10
-  left  825 0332 10
-  ↔  840 0394 10
-  right  840 1143 10
-  left  840 1142 10

2.3 dCi 130 FWD (EV0Y, HV0Y, UV0M, UV0Y)

















M9T 704; M9T 882; (96kW)

03.12-





-  M9T 704  626 3049 33
- SAC  626 3049 33



-   07.15 →; A/C  529 0317 10
-   07.15 →;  A/C  529 0353 10
-   07.15 →  532 0534 10
-     534 0281 10
-   A/C  FB 7PK1685































































































-  right  821 0865 10
-  left  821 0868 10



			SCHAEFFLER
--	--	--	-------------------

RENAULT





























































MASTER III			
2.3 dCi 130 FWD (EV0Y, HV0Y, UV0M, UV0Y) M9T 704; M9T 882; (96kW)	03.12-	FAG	  713 6450 40
			 90 mm
			  713 6450 50
			 80 mm
			 ↔
			 ↔
			 ↔
			 right
			 left
			  821 0865 10
			  840 1142 10
			2.3 dCi 130 RWD (FV01, FV10, FV11, FV12) M9T 710; (96kW)
incl. 			
	 ; 07.15 →; A/C		
	 ; 07.15 →; A/C ; 		
			
	  534 0281 10		
FAG	 right		
	 left		
	  713 6450 40		
	 90 mm		
	 ; 		
	 ;   713 6451 60		
	 90 mm		
	 ↔		
	 ↔		
	 ; 		
 ↔			
 right			
 left			
2.3 dCi 130 FWD (FV0M, FV0Y) M9T 704; M9T 710; M9T 882; (96kW)	06.16-	LUK	 M9T 704
			SAC
			 ;  BM Master T28/T33/T35; A/C
			 ;  ; A/C
			
			  534 0281 10
		FAG	 # F-236675.XX F-561464.XX
			 # F-552305.XX
			 ; A/C
			 right
			 left
			  713 6450 40
 90 mm			
  713 6450 50			
 80 mm			
 ↔			
 ↔			
 ↔			
 right			
 left			
2.3 dCi 130 RWD (HV01, HV10, HV11, HV12, UV01, UV10, ...) M9T 710; (96kW)	07.16-	LUK	 M9T 692
			 M9T 692
			incl. 
			 ; A/C
			 ; A/C ; FWD
			 ; A/C ; 
		FAG	
			 ; A/C 
			 right
			 left
			  713 6450 40
			 90 mm
 ; 			
 ;   713 6451 60			
 90 mm			
 ; 			
 ↔			
 ↔			
right			
left			



			<p>SCHAEFFLER</p>
--	--	--	-------------------

RENAULT

MASTER III























































































<p>2.3 dCi 135 FWD (EV0N, HV0N, UV0N, EV08, HV08, UV08) M9T 702; M9T 716; (100kW)</p>	<p>07.14-</p>	<p>LUK PF6 SAC SAC</p> <p>INA A/C A/C; b</p> <p>FAG right left 90 mm 80 mm ↔ ↔ ↔ right left</p>	<p> 626 3049 09  626 3049 33  529 0355 10  529 0356 10  532 0534 10  534 0281 10  821 0865 10  821 0868 10  Set 713 6450 40  Set 713 6450 50  818 0482 10  818 0475 10  840 0394 10  840 1143 10  840 1142 10</p>
<p>2.3 dCi 135 FWD (FV0N, FV08) 2.3 dCi 165 FWD (EV0P, EV0U, EV11, EV12, HV0P, HV0U, ...) M9T 702; M9T 708; M9T 716; (100-120kW)</p>	<p>07.14-</p>	<p>LUK SAC</p> <p>INA A/C A/C; b</p> <p>FAG right left 90 mm 80 mm ↔ ↔ right left ↔ right left</p>	<p> 626 3049 33  529 0355 10  529 0356 10  532 0534 10  534 0281 10  535 0080 10  535 0153 10  821 0865 10  821 0868 10  Set 713 6450 40  Set 713 6450 50  818 0482 10  818 0475 10  825 0333 10  825 0332 10  840 0394 10  840 1143 10  840 1142 10</p>
<p>2.3 dCi 135 FWD (JV0N) M9T 702; (100kW)</p>	<p>07.14-</p>	<p>LUK SAC</p> <p>INA M9T 702; A/C A/C; b</p> <p>FAG right left 90 mm 80 mm ↔ ↔ right left ↔ right left</p>	<p> 626 3049 33  529 0355 10  529 0356 10  532 0534 10  534 0281 10  535 0080 10  535 0153 10  FB 7PK1685  821 0865 10  821 0868 10  Set 713 6450 40  Set 713 6450 50  818 0482 10  818 0475 10  825 0333 10  825 0332 10  840 0394 10  840 1143 10  840 1142 10</p>
<p>2.3 dCi 135 RWD (FV0N) M9T 700; (100kW)</p>	<p>07.14-</p>	<p>LUK incl. </p> <p>INA A/C M9T 702; A/C A/C; b</p> <p>FAG right left</p>	<p> 626 3050 00  415 0490 10  529 0354 10  529 0355 10  529 0356 10  532 0534 10  534 0281 10  535 0080 10</p>



			SCHAEFFLER
--	--	--	-------------------

RENAULT

MASTER III























































































2.3 dCi 135 RWD (FV0N) M9T 700; (100kW)	07.14-	 FAG	F-552305.XX 	 535 0153 10  FB 7PK1685			
			right 	 821 0865 10  821 0868 10  713 6450 40			
			left 	 713 6450 30  713 6451 60			
			90 mm 	 818 0482 10  818 0475 10  818 0492 10			
			90 mm 	 825 0333 10  825 0332 10  840 0394 10			
			right 	 840 1143 10  840 1142 10			
			left 	 626 3050 00  415 0490 10			
			A/C 	 529 0354 10  529 0355 10  529 0356 10  532 0534 10  534 0281 10			
			M9T 702; A/C 	 535 0080 10  535 0153 10  FB 7PK1685			
			right 	 821 0865 10  821 0868 10  713 6450 40			
			left 	 713 6450 30  713 6451 60			
			90 mm 	 818 0482 10  818 0475 10  818 0492 10			
			90 mm 	 825 0333 10  825 0332 10  840 0394 10			
			right 	 840 1143 10  840 1142 10			
			left 	 600 0235 00  626 3049 09  626 3049 33  415 0485 10			
			2.3 dCi 145 FWD (EVOE, EVOF, HV0E, HV0F, UV0E, UV0F, ..) M9T 678; M9T 680; M9T 706; M9T 708; (107kW)	02.10-	 FAG	PF6 incl.  ; incl.  ; SAC	 600 0235 00  626 3049 09  626 3049 33  415 0485 10
						M9T 678 M9T 680 	 529 0317 10  529 0353 10  532 0534 10  534 0281 10
F-236675.XX F-561464.XX F-552305.XX	 535 0080 10  535 0153 10  FB 7PK1685  FB 7PK1973						
A/C; PTO 	 538 0397 10  420 0086 10						
A/C 	 422 0078 10  558 0060 10  559 0172 10  559 0172 30						
A/C; PTO 	 821 0865 10  821 0868 10						
right 							
left 							



			SCHAEFFLER
--	--	--	-------------------

RENAULT





























































































































MASTER III

<p>2.3 dCi 145 FWD (EV0E, EV0F, HV0E, HV0F, UV0E, UV0F, ..) M9T 678; M9T 680; M9T 706; M9T 708; (107kW)</p>	02.10-	FAG	 Set 713 6450 40			
			 90 mm Set 713 6450 50			
			 80 mm			
			 ↔ 818 0482 10			
			 ↔ 818 0475 10			
			 right; 07.10→ 825 0333 10			
			 left 825 0332 10			
			 right; →07.10			
			 ↔ 840 0394 10			
			 right 840 1143 10			
			 left 840 1142 10			
			2.3 dCi 145 FWD (FV0E, FV0F, FV0H, FV02, FV0M, FV0S, ..) M9T 678; M9T 680; M9T 706; M9T 708; (107kW)		02.10-	LUK
			 M9T 678 M9T 680;  PF6 incl.  ; SAC Set 600 0235 00			
			 M9T 678 M9T 680 SAC Set 626 3049 09			
			 M9T 678 M9T 680;  PF6 SAC Set 626 3049 33			
			 M9T 678 M9T 680 incl.  Set 415 0485 10			
			  ;  BM Master T28/T33/T35 Set 529 0317 10			
			 ;  ;  ;  Set 529 0353 10			
 Set 532 0534 10						
 ;  ;  Set 532 0668 10						
 Set 534 0281 10						
 # F-236675.XX F-561464.XX Set 535 0080 10						
 # F-552305.XX Set 535 0153 10						
 ;  M9T 706 M9T 708;  ;  Set FB 7PK1668						
 ;  ;  Set FB 7PK1685						
 ;  ;  Set FB 7PK1973						
 Set 538 0397 10						
16x  12 mm Set 420 0086 10						
16x  Set 422 0078 10						
1x  KIT 558 0060 10						
1x  KIT 559 0172 10						
1x  KIT 559 0172 30						
FAG	 right 821 0865 10					
	 left 821 0868 10					
	 90 mm Set 713 6450 40					
	 80 mm Set 713 6450 50					
	 ↔ 818 0482 10					
	 right; 07.10→ 825 0333 10					
	 left 825 0332 10					
	 right; →07.10					
	 ↔ 840 0394 10					
	 right 840 1143 10					
	 left 840 1142 10					
	2.3 dCi 145 RWD (FV0E, FV0F, FV0T, FV10, FV12) M9T 694; M9T 696; M9T 698; M9T 710; (107kW)		02.10-	LUK		
	 M9T 694 M9T 698 Set 626 3050 00					
	 M9T 694 M9T 698 incl.  Set 415 0490 10					
	  ;  Set 529 0352 10					
	 ;  ;  Set 529 0353 10					
	 ;  ;  Set 532 0534 10					
	 Set 534 0281 10					
 # F-236675.XX F-561464.XX Set 535 0080 10						
 # F-552305.XX Set 535 0153 10						
 ;  M9T 710;  ;  Set FB 7PK1668						
 ;  ;  Set FB 7PK1685						
 Set 420 0086 10						
16x  12 mm Set 422 0078 10						
1x  KIT 558 0060 10						
1x  KIT 559 0172 10						
1x KIT 559 0172 30						



			SCHAEFFLER
--	---	--	-------------------

RENAULT

MASTER III						
2.3 dCi 145 RWD (FV0E, FV0F, FV0T, FV10, FV12) M9T 694; M9T 696; M9T 698; M9T 710; (107kW)	02.10-	FAG	 right  821 0865 10			
			 left  821 0868 10			
			 90 mm  Set 713 6450 40			
			 90 mm  Set 713 6450 30			
			 90 mm  Set 713 6451 60			
			 ↔  818 0482 10			
			 ↔;   818 0475 10			
			 ↔;   818 0492 10			
			 right; 07.10→  825 0333 10			
			 left  825 0332 10			
			 right; →07.10  840 0394 10			
			 ↔  840 1143 10			
			 right  840 1142 10			
			 left  626 3050 00			
			 M9T 694 M9T 698  415 0490 10			
			 M9T 694 M9T 698 incl.   529 0352 10			
			2.3 dCi 145 RWD (UV0F, UV0E, HV0E, HV0F, HV0T, HV10, ...) M9T 694; M9T 696; M9T 698; M9T 710; (107kW)	02.10-	LUK	 A/C  529 0353 10
						 A/C;   532 0534 10
 A/C  534 0281 10						
 F-236675.XX F-561464.XX  535 0080 10						
 F-552305.XX  535 0153 10						
 A/C; PTO  FB 7PK1685						
16x  420 0086 10						
 12 mm  422 0078 10						
16x  558 0060 10						
1x  559 0172 10						
1x  559 0172 30						
FAG	 right  821 0865 10					
	 left  821 0868 10					
	 90 mm  Set 713 6450 40					
	 90 mm  Set 713 6450 30					
	 90 mm  Set 713 6451 60					
	 ↔  818 0482 10					
	 ↔;   818 0475 10					
	 ↔;   818 0492 10					
	 right; 07.10→  825 0333 10					
	 left  825 0332 10					
	 right; →07.10  840 0394 10					
	 ↔  840 1143 10					
	 right  840 1142 10					
	 left  600 0235 00					
	 M9T 680; M9T 706; M9T 708; (107kW)  626 3049 33					
	 M9T 680; M9T 706; M9T 708; (107kW)  415 0485 10					
	2.3 dCi 145 FWD (JV0F, JV0S, JV0T) M9T 680; M9T 706; M9T 708; (107kW)	02.11-	LUK	incl.  ; incl.  ; SAC  529 0317 10		
				SAC  626 3049 33		
incl.   415 0485 10						
 BM Master T28  529 0317 10						
 10.12→;  BM Master T30  529 0353 10						
 10.12→;  BM Master T33  529 0356 10						
 BM Master T35  532 0534 10						
 10.12→;  A/C  534 0281 10						
 10.12→;  M9T 706; A/C;   535 0080 10						
 F-236675.XX F-561464.XX  535 0153 10						
 F-552305.XX  FB 7PK1668						
 M9T 706; A/C;   FB 7PK1685						
 A/C; PTO  FB 7PK1973						
 A/C  538 0397 10						
 A/C; PTO  538 0397 10						



























			<p>SCHAEFFLER</p>
--	--	--	--------------------------

RENAULT

MASTER III





















































2.3 dCi 145 FWD (JV0F, JV0S, JV0T)
 M9T 680; M9T 706; M9T 708;
 (107kW)

02.11-

	16x  12 mm 16x 1x 1x 1x	    	420 0086 10 422 0078 10 558 0060 10 559 0172 10 559 0172 30
<p>FAG</p> 	right left  90 mm  80 mm  ↔  ↔ right left  ↔ right left	           	821 0865 10 821 0868 10 713 6450 40 713 6450 50 818 0482 10 818 0475 10 825 0333 10 825 0332 10 840 0394 10 840 1143 10 840 1142 10



























2.3 dCi 150 FWD (JV0F)
 M9T 880; (110kW)

10.12-

	incl.  ; incl.  ; SAC MANU SAC SAC incl. 	    	600 0235 00 626 3049 09 626 3049 33 415 0485 10
	03.13→;  BM Master T30 03.13→;  BM Master T33 03.13→;  BM Master T35 03.13→;  BM Master T45 03.13→;  	       	529 0317 10 529 0353 10 532 0534 10 534 0281 10 535 0080 10 535 0153 10 FB 7PK1685 538 0397 10
	16x  12 mm 16x 1x 1x 1x	    	420 0086 10 422 0078 10 558 0060 10 559 0172 10 559 0172 30
<p>FAG</p> 	right left  90 mm  80 mm  ↔  ↔ right left  ↔ right left	               	821 0865 10 821 0868 10 713 6450 40 713 6450 50 818 0482 10 818 0475 10 825 0333 10 825 0332 10 840 0394 10 840 1143 10 840 1142 10

2.3 dCi 150 FWD (EV0F, HV0F, UV0F,
 EV03, HV03, UV03)
 M9T 716; M9T 880; (110kW)

03.13-













































































































	incl.  ; incl.  ; SAC SAC incl. 	   	600 0235 00 626 3049 33 415 0485 10
	03.13→;   03.13→;   03.13→;   03.13→;  	         	529 0317 10 529 0353 10 532 0534 10 534 0281 10 535 0080 10 535 0153 10 FB 7PK1685 538 0397 10 420 0086 10 422 0078 10



			SCHAEFFLER
--	---	--	-------------------

RENAULT

MASTER III















































































2.3 dCi 150 FWD (EV0F, HV0F, UV0F, EV03, HV03, UV03) M9T 716; M9T 880; (110kW)	03.13-	 FAG	1x		558 0060 10
			1x		559 0172 10
			1x		559 0172 30
			 right		821 0865 10
			 left		821 0868 10
			 90 mm		713 6450 40
			 80 mm		713 6450 50
			 ↔		818 0482 10
			 ↔		818 0475 10
			 right		825 0333 10
			 left		825 0332 10
			 ↔		840 0394 10
			 right		840 1143 10
			 left		840 1142 10
			2.3 dCi 150 FWD (FV0F, FV03) M9T 716; M9T 880; (110kW)	03.13-	 LUK
incl.  ; incl.  ; SAC					
M9T 880		626 3049 33			
SAC					
incl. 		415 0485 10			
 ;  BM Master T28		529 0317 10			
 ;  BM Master T33					
 ;  BM Master T35					
 ;  BM Master T45					
 ;  ; A/C		529 0353 10			
		532 0534 10			
		534 0281 10			
## F-236675.XX F-561464.XX		535 0080 10			
## F-552305.XX		535 0153 10			
 ; A/C		FB 7PK1685			
		538 0397 10			
16x		420 0086 10			
 12 mm					
16x		422 0078 10			
1x		558 0060 10			
1x		559 0172 10			
1x		559 0172 30			
 right		821 0865 10			
 left		821 0868 10			
 90 mm		713 6450 40			
 80 mm		713 6450 50			
 ↔		818 0482 10			
 ↔		818 0475 10			
 right		825 0333 10			
 left		825 0332 10			
 ↔		840 0394 10			
 right		840 1143 10			
 left		840 1142 10			
2.3 dCi 150 RWD (FV0F) M9T 896; M9T 898; (110kW)	03.13-	 LUK			626 3050 00
			incl. 		415 0490 10
			 ; A/C		529 0352 10
			 ; A/C; 		
			 ;  ; A/C		529 0353 10
					532 0534 10
					534 0281 10
			## F-236675.XX F-561464.XX		535 0080 10
			## F-552305.XX		535 0153 10
			 ; A/C		FB 7PK1685
			16x		420 0086 10
			 12 mm		
			16x		422 0078 10
			1x		558 0060 10
			1x		559 0172 10
1x		559 0172 30			
 right		821 0865 10			



			<p>SCHAEFFLER</p>
--	--	--	--------------------------

RENAULT

MASTER III

<p>2.3 dCi 150 RWD (FV0F) M9T 896; M9T 898; (110kW)</p>	<p>03.13-</p>	<p>FAG</p>	<p>left  left  90 mm  ;   ;   90 mm  ↔  ↔;   ↔;  right left  ↔ right left</p>	<p> 821 0868 10  Set 713 6450 40  Set 713 6450 30  Set 713 6451 60  818 0482 10  818 0475 10  818 0492 10  825 0333 10  825 0332 10  840 0394 10  840 1143 10  840 1142 10</p>
<p>2.3 dCi 150 RWD (HV0F, UV0F) M9T 896; M9T 898; (110kW)</p>	<p>03.13-</p>	<p>LUK</p> <p></p>	<p>ZF4 ZF4 incl.   ; A/C  ; A/C ;   ;  ; A/C   # F-236675.XX F-561464.XX # F-552305.XX  ; A/C 16x  12 mm 16x 1x 1x 1x</p>	<p> 626 3050 00  415 0490 10  529 0352 10  529 0353 10  532 0534 10  534 0281 10  535 0080 10  535 0153 10  FB 7PK1685  420 0086 10  422 0078 10  KIT 558 0060 10  KIT 559 0172 10  KIT 559 0172 30</p>
<p>2.3 dCi 165 FWD (FV0P, FV0U, FV11, FV12) M9T 702; M9T 708; (120kW)</p>	<p>07.14-</p>	<p>LUK</p> <p></p> <p>FAG</p>	<p>SAC  ; A/C  ; A/C ;    # F-236675.XX F-561464.XX # F-552305.XX  ; A/C right left  90 mm  80 mm  ↔  ↔ right left  ↔ right left</p>	<p> 626 3049 33  529 0355 10  529 0356 10  532 0534 10  534 0281 10  535 0080 10  535 0153 10  FB 7PK1685  821 0865 10  821 0868 10  Set 713 6450 40  Set 713 6450 50  818 0482 10  818 0475 10  825 0333 10  825 0332 10 840 0394 10 840 1143 10 840 1142 10</p>

















































			SCHAEFFLER
--	--	--	-------------------

RENAULT

MASTER III





















































2.3 dCi 165 FWD (JV0P, JV0U)
 M9T 702; M9T 708; (120kW)

07.14-

	SAC		626 3049 33	
		 ;  M9T 702; A/C		529 0355 10
		 ; A/C; 		529 0356 10
				532 0534 10
				532 0668 10
		 ; 07.15-→; A/C		534 0281 10
				535 0080 10
		 # F-236675.XX F-561464.XX		535 0153 10
		 # F-552305.XX		FB 7PK1685
		 ; A/C		
		FAG	 right	
	 left			821 0868 10
				713 6450 40
	 90 mm			
 80 mm			713 6450 50	
 ↔			818 0482 10	
 ↔			818 0475 10	
 right			825 0333 10	
 left			825 0332 10	
 ↔			840 0394 10	
 right		840 1143 10		
 left		840 1142 10		

















































2.3 dCi 165 RWD (FV0P, FV0U, FV10, FV12)
 M9T 700; M9T 710; (120kW)

07.14-

	incl. 		626 3050 00		
		 ; A/C		529 0354 10	
		 ; A/C; 		529 0356 10	
				532 0534 10	
				534 0281 10	
		 # F-236675.XX F-561464.XX		535 0080 10	
		 # F-552305.XX		535 0153 10	
		 ; A/C		FB 7PK1685	
		FAG	 right		821 0865 10
			 left		821 0868 10
					713 6450 40
	 90 mm				
	 ; 			713 6450 30	
	 ; 			713 6451 60	
 90 mm					
 ↔			818 0482 10		
 ↔			818 0475 10		
 ; 			818 0492 10		
 right		825 0333 10			
 left		825 0332 10			
 ↔		840 0394 10			
 right		840 1143 10			
 left		840 1142 10			

2.3 dCi 165 RWD (HV0P, HV0U, HV10, HV12, UV0P, UV0U, ...)
 M9T 700; M9T 710; (120kW)

07.14-











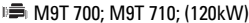









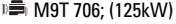

































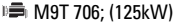









































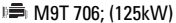























	incl. 		626 3050 00	
		 ; A/C		529 0354 10
		 ;  M9T 702; A/C		529 0355 10
		 ; A/C; 		529 0356 10
				532 0534 10
				534 0281 10
		 # F-236675.XX F-561464.XX		535 0080 10
		 # F-552305.XX		535 0153 10
		 ; A/C; FWD		FB 7PK1675
		 ; A/C		FB 7PK1685
		FAG	 right	
	 left			821 0868 10
				713 6450 40
	 90 mm			
 ; 			713 6450 30	
 ; 			713 6451 60	
 90 mm				
 ↔			818 0482 10	
 ↔; 			818 0475 10	
 ; 			818 0492 10	



			SCHAEFFLER
--	--	--	-------------------

RENAULT































































































MASTER III

<p>2.3 dCi 165 RWD (HV0P, HV0U, HV10, HV12, UV0P, UV0U, ..) </p>	07.14-	FAG	 right		825 0333 10				
			 left		825 0332 10				
			 ↔		840 0394 10				
			 right		840 1143 10				
			 left		840 1142 10				
			<p>2.3 dCi 170 FWD (FV0L) </p>	07.15-	LUK	SAC		626 3049 33	
							 A/C ; FWD		529 0355 10
							 A/C		529 0356 10
									532 0534 10
							 A/C		532 0668 10
									534 0281 10
						 # F-236675.XX F-561464.XX		535 0080 10	
						 # F-552305.XX		535 0153 10	
						FAG	 right		821 0865 10
							 left		821 0868 10
 90 mm		713 6450 40							
 80 mm		713 6450 50							
 ↔		818 0482 10							
 ↔		818 0475 10							
 ↔		840 0394 10							
 right		840 1143 10							
 left		840 1142 10							
<p>2.3 dCi 170 FWD (JV0L) </p>	07.15-	LUK	 PF6		626 3049 33				
				 A/C ; FWD			529 0355 10		
				 A/C			529 0356 10		
							532 0534 10		
				 A/C			532 0668 10		
							534 0281 10		
			 # F-236675.XX F-561464.XX		535 0080 10				
			 # F-552305.XX		535 0153 10				
					FB 7PK1675				
			FAG	 right		821 0865 10			
				 left		821 0868 10			
				 90 mm		713 6450 40			
				 80 mm		713 6450 50			
				 ↔		818 0482 10			
				 ↔		818 0475 10			
 right		825 0333 10							
 left		825 0332 10							
 ↔		840 0394 10							
 right		840 1143 10							
 left		840 1142 10							
<p>2.3 dCi 170 FWD (EV0L, HV0L, UV0L) </p>	06.16-	LUK		 M9T 706		626 3049 09			
					SAC		626 3049 33		
					 A/C ; FWD		529 0355 10		
					 A/C		529 0356 10		
						532 0534 10			
						534 0281 10			
			 # F-236675.XX F-561464.XX		535 0080 10				
			 # F-552305.XX		535 0153 10				
			FAG	 right		821 0865 10			
				 left		821 0868 10			
				 90 mm		713 6450 40			
				 80 mm		713 6450 50			
				 ↔		818 0482 10			
				 ↔		818 0475 10			
				 ↔		840 0394 10			
 right		840 1143 10							
 left		840 1142 10							

			SCHAEFFLER
--	---	--	-------------------

RENAULT

TRAFIC II Box (FL)













































































1.9 dCi F9Q 762; (59kW)	04.01-07.03		→01.03		624 3087 09	
			→01.03; PK5.0##		624 3087 33	
			→01.03; PK5.3##		624 3087 34	
			02.03→		624 3312 09	
			02.03→; PK5.0##		624 3312 33	
			02.03→; PK5.3##		624 3312 34	
						530 0196 10
						530 0196 30
						533 0087 20
				 ; +  ; →03.02; A/C		529 0118 10
		 ; 03.02→; A/C			529 0124 10	
		 ; A/C			529 0427 10	
		 ; →03.02; A/C			532 0243 10	
		 ; A/C			534 0142 30	
		## F-560843.XX F-556602.XX F-229643.XX			535 0030 10	
		## F-234637.XX			535 0048 10	
			 right		821 0490 10	
			 left		821 0489 10	
			 ; ABS; →11.02		713 6441 20	
			 86 mm		713 6441 30	
			 ; ABS; →11.02		713 6442 90	
			 86 mm		713 6441 40	
			 ; 11.02→		713 6442 90	
			 88 mm		713 6441 40	
			 68 mm		814 0135 10	
 ↔			818 0207 10			
			825 0260 10			
			840 0274 10			
 right			840 0880 10			
 left			840 0879 10			
	G5; PK5.011		GearBOX	462 0155 10		
	G6; PK6.011	GearBOX	462 0203 10			
	G6; PK6.363	GearBOX	462 0203 10			
	→01.03		624 3087 09			
	→01.03; PK5.0##		624 3087 33			
	→01.03; PK5.3##		624 3087 34			
	02.03→		624 3312 09			
	02.03→; PK5.0##		624 3312 33			
	02.03→; PK5.3##		624 3312 34			
				530 0196 10		
			530 0196 30			
			533 0087 20			
 ; +  ; →03.02; A/C			529 0118 10			
 ; 03.02→07.06; A/C			529 0124 10			
 ; →07.06; A/C			529 0427 10			
 ; →03.02; A/C			532 0243 10			
 ; A/C; →07.06			534 0142 30			
 ; A/C			534 0240 10			
## F-560843.XX F-556602.XX F-229643.XX			535 0030 10			
## F-234637.XX			535 0048 10			
OPTION			544 0089 10			
A/C			544 0101 10			
A/C			544 0101 20			
 ; A/C			FB 6PK1795			
 ; A/C; PTO		FB 6PK1830				
		538 0392 10				
1x		553 0124 10				
	 right; →11.06		821 0490 10			
	 right; 12.06→		821 0822 10			
	 left; →11.06		821 0489 10			
	 left; 12.06→		821 0821 10			



			SCHAEFFLER
--	--	--	-------------------

RENAULT

TRAFIC II Box (FL)















































































































1.9 dCi 80 (FLOB) F9Q 760; F9Q 762; (60kW)	03.01-	FAG	ABS ; →11.02		713 6441 20
			 86 mm		713 6441 30
			ABS ; →11.02		713 6442 90
			 86 mm		713 6441 40
			11.02→		771 0507 30
			 88 mm		815 0068 30
					818 0207 10
			↔		825 0260 10
			12.06→		825 0261 10
					840 0274 10
			right		840 0880 10
			left		840 0879 10
					462 0155 10
					624 3087 09
					624 3087 33
		624 3087 34			
		624 3312 09			
		624 3312 33			
		624 3312 34			
		530 0196 10			
		530 0196 30			
		533 0087 20			
		529 0118 10			
		529 0124 10			
		529 0427 10			
		532 0243 10			
		532 0364 20			
		534 0142 30			
		534 0240 10			
		535 0030 10			
		535 0048 10			
	OPTION		544 0089 10		
	A/C		544 0101 10		
	A/C		544 0101 20		
	A/C		FB 6PK1795		
	A/C ; PTO		FB 6PK1830		
	→07.06; A/C ; e		FB 6PK1835		
			538 0392 10		
	right; →11.06		821 0490 10		
	right; 12.06→		821 0822 10		
	left; →11.06		821 0489 10		
	left; 12.06→		821 0821 10		
	ABS ; →11.02		713 6441 20		
	 86 mm		713 6441 30		
	ABS ; →11.02		713 6442 90		
	 86 mm		713 6441 40		
	11.02→		771 0507 30		
	 88 mm		815 0068 30		
			818 0207 10		
	↔		825 0260 10		
	12.06→		825 0261 10		
			840 0274 10		
	right		840 0880 10		
	left		840 0879 10		
			624 3087 09		
			624 3087 33		
			624 3312 09		
			530 0196 10		
			530 0196 30		
			533 0087 20		
1.9 dCi F9Q 760; (75kW)	03.01-	LUK	→01.03		624 3087 09
			→01.03; PK5		624 3087 33
			01.03→		624 3312 09
			530 0196 10		
			530 0196 30		
			533 0087 20		



			SCHAEFFLER
--	---	--	-------------------

RENAULT

TRAFIC II Box (FL)

<p>1.9 dCi  F9Q 760; (75kW)</p>	03.01-		 ; +  ; →03.02; A/C	 529 0118 10	
			 ; 01.06→; A/C	 529 0124 10	
			 ; 01.06→; A/C ; -e	 529 0427 10	
			 ; →03.02; A/C	 532 0243 10	
			 ; 03.02→; A/C	 532 0364 20	
			 ; A/C ; 01.06→	 534 0142 30	
			 ; A/C	 534 0240 10	
			## F-560843.XX F-556602.XX F-229643.XX	 535 0030 10	
			OPTION	 544 0089 10	
			 ; A/C	 FB 6PK1795	
			 ; A/C ; PTO	 FB 6PK1830	
			 ; 06.06→; A/C ; -e	 FB 6PK1835	
				 538 0392 10	
		FAG	 right; →11.06	 821 0490 10	
			 right; 12.06→	 821 0822 10	
			 left; →11.06	 821 0489 10	
			 left; 12.06→	 821 0821 10	
			 88 mm	 Set 713 6442 90	
			 68 mm	 Set 713 6441 40	
			 ↔	 814 0135 10	
 ; 12.06→	 818 0207 10				
 right	 825 0261 10				
 left	 840 0274 10				
	 840 0880 10				
	 840 0879 10				
	 624 3476 09				
	 624 3476 34				
	 529 0317 10				
<p>2.0 dCi 115 (FL01, FLOU) 2.0 dCi 90 (FLOH)  M9R 630; M9R 692; M9R 780; M9R 782; M9R 786; (66-84kW)</p>	08.06-		LUK	 PF6.0##	 529 0317 10
				 ; A/C	 535 0080 10
		 ; A/C		 FB 7PK1741	
				 FB 7PK1973	
		16x		 538 0397 10	
		 12 mm		 420 0086 10	
		16x		 422 0078 10	
		1x		 KIT 558 0059 10	
		1x		 KIT 559 0171 10	
		1x		 KIT 559 0171 30	
		FAG	 right; →11.06	 821 0490 10	
			 right; 12.06→	 821 0822 10	
			 left; →11.06	 821 0489 10	
			 left; 12.06→	 821 0821 10	
			 88 mm	 Set 713 6442 90	
			 68 mm	 Set 713 6441 40	
			 ; ←	 771 0561 30	
			 left  ← ; 03.13→; G5	 SET 772 0230 30	
			 ↔	 REP 815 0068 30	
			 ; 12.06→	 818 0207 10	
	 825 0260 10				
	 825 0261 10				
	 840 0274 10				
	 840 0880 10				
	 840 0879 10				
<p>2.0 16V  F4R 820; (86kW)</p>	08.06-	LUK	G6 ;  PK6.372 PK6.384 PK6.385	GearBOX 462 0203 10	
				 624 3092 33	
			 ; A/C	 529 0124 10	
		 ; A/C	 529 0427 10		
		## F-560843.XX F-556602.XX F-229643.XX	 535 0030 10		
		## F-234637.XX	 535 0048 10		
			 538 0392 10		
		16x	 420 0099 10		
		 12 mm	 422 0009 10		
		16x	 821 0490 10		
FAG	 right; →11.06	 821 0490 10			
	 right; 12.06→	 821 0822 10			



			SCHAEFFLER
--	--	--	-------------------

RENAULT

TRAFIC II Box (FL)







































































































2.0 16V F4R 820; (86kW)	08.06-	FAG	left; →11.06		821 0489 10
			left; 12.06→		821 0821 10
			88 mm	Set	713 6442 90
			68 mm	Set	713 6441 40
					771 0507 30
				REP	815 0068 30
			↔		818 0207 10
					825 0260 10
			; 12.06→		825 0261 10
					840 0274 10
			right		840 0880 10
			left		840 0879 10
					624 3092 09
					624 3092 33
					624 3092 34
2.0 (FLOA) F4R 720; F4R 722; (88kW)	03.01-	LUK	G6 ; PK6.009	GearBOX	462 0155 10
			G6 ; PK6.372	GearBOX	462 0203 10
					624 3092 09
		PK6.3##		624 3092 33	
		PK6.0##		624 3092 34	
			; A/C		529 0124 10
			; A/C		529 0427 10
			; →02.09; F4R 720; A/C		534 0240 10
			# F-560843.XX F-556602.XX F-229643.XX		535 0030 10
			# F-234637.XX		535 0048 10
					538 0392 10
			16x		420 0099 10
			12 mm		
			16x		422 0009 10
			FAG	right; →11.06	
right; 12.06→				821 0822 10	
left; →11.06				821 0489 10	
left; 12.06→		821 0821 10			
; ABS ; →11.02	Set	713 6441 20			
; ABS ; →11.02	Set	713 6441 30			
86 mm					
; 11.02→	Set	713 6442 90			
88 mm					
68 mm	Set	713 6441 40			
		771 0507 30			
	REP	815 0068 30			
↔		818 0207 10			
		825 0260 10			
; 12.06→		825 0261 10			
		840 0274 10			
right		840 0880 10			
left		840 0879 10			
2.5 dCi G9U 630; (84kW)	08.07-	LUK			624 3476 34
					530 0198 10
					531 0548 10
					532 0313 20
			; A/C;		529 0428 10
			; A/C; # OE 7PK1835		529 0437 10
			; A/C; ; # OE 7PK1835		
			; →09.10; A/C		532 0364 20
			; →09.10; A/C		
			; 09.10→; A/C		532 0534 10
			; 09.10→; A/C		
			; A/C		534 0181 10
			; A/C;		
			; A/C;		534 0317 10
					544 0110 10
; A/C		FB 7PK1795			
; A/C ; # OE 8200833558		FB 7PK1795			
; A/C;		FB 7PK1835			
		538 0374 10			
1x;		428 0185 10			



			SCHAEFFLER
--	---	--	-------------------

RENAULT

TRAFIC II Box (FL)

2.5 dCi G9U 630; (84kW)	08.07-	 FAG	1x; 		428 0186 10			
			 right		821 0822 10			
			 left		821 0821 10			
			 88 mm	 Set	713 6442 90			
			 68 mm	 Set	713 6441 40			
					814 0135 10			
			 ↔		818 0207 10			
					825 0261 10			
					840 0274 10			
			 right		840 0880 10			
			 left		840 0879 10			
					600 0078 00			
					623 3159 09			
					623 3159 33			
					623 3159 34			
			2.5 DTi G9U 730; (99kW)	03.03-07.03	 LUK	PK6.0## SEMI ; PA6.0## incl. O; incl.  SAC		600 0078 00
						PK6.3## SAC		623 3159 33
PK6.0## SEMI ; PA6.0## SAC incl. 		623 3159 34						
		415 0146 10						
		530 0198 10						
		531 0548 10						
		532 0313 20						
 ; A/C ;  ; # OE 6PK1835		529 0436 10						
		532 0364 20						
 ; A/C		534 0181 10						
 INA	 ; A/C ; 				534 0317 10			
	 # F-560843.XX F-556602.XX F-229643.XX				535 0030 10			
	 ; A/C				FB 6PK1153			
	 ; A/C				FB 6PK1795			
	 ; A/C				FB 6PK1835			
	 ; A/C ; 				538 0374 10			
	16x  11 mm				420 0063 10			
	1x; 				428 0185 10			
	1x; 				428 0186 10			
	FAG	 right				821 0490 10		
 left			821 0489 10					
 88 mm		 Set	713 6442 90					
 68 mm		 Set	713 6441 40					
			814 0135 10					
 ↔			818 0207 10					
			825 0260 10					
			840 0274 10					
 right			840 0880 10					
 left			840 0879 10					
2.5 dCi 135 (FL0D) G9U 730; (99kW)	05.03-	 LUK	→06.04; PK6.0## incl. O; incl.  SAC		600 0078 00			
			→06.04 SAC		623 3159 09			
			→06.04; PK6.3## SAC		623 3159 33			
			→06.04; PK6.0## SAC		623 3159 34			
			07.04→		624 3945 09			
			07.04→; PK6.3##		624 3945 33			
			07.04→; PK6.0##		624 3945 34			
			→06.04 incl. 		415 0146 10			
					530 0198 10			
					531 0548 10			



			<p>SCHAEFFLER</p>
--	--	--	--------------------------

RENAULT

TRAFIC II Box (FL)

2.5 dCi 135 (FLOD)
 G9U 730; (99kW)

05.03-



	16x		532 0313 20
	11 mm		529 0436 10
	1x;		532 0364 20
	1x;		534 0181 10
			534 0317 10
			535 0030 10
			544 0094 10
			FB 6PK1153
			FB 6PK1795
			FB 6PK1835
			FB 6PK1835
			538 0374 10
			420 0063 10
			428 0185 10
			428 0186 10
			821 0490 10
			821 0822 10
			821 0489 10
			821 0821 10
			713 6442 90
			713 6441 40
			815 0068 30
			818 0207 10
			825 0260 10
			825 0261 10
			840 0274 10
			840 0880 10
			840 0879 10

FAG

			624 3476 09
			624 3476 34
			530 0198 10
			531 0548 10
			532 0313 20
			529 0428 10
			529 0437 10
			532 0364 20
			532 0534 10
			534 0181 10
			534 0317 10
			535 0081 10
			544 0098 10
			544 0110 10
			FB 7PK1795
			FB 7PK1835
			538 0374 10
			420 0063 10
			428 0185 10
			428 0186 10
			821 0490 10
			821 0822 10
			821 0489 10
			821 0821 10
			713 6442 90
			713 6441 40
			771 0561 30
			772 0230 30

2.5 dCi 145 (FLOJ)
 G9U 630; (107kW)

08.06-



			624 3476 09
			624 3476 34
			530 0198 10
			531 0548 10
			532 0313 20
			529 0428 10
			529 0437 10
			532 0364 20
			532 0534 10
			534 0181 10
			534 0317 10
			535 0081 10
			544 0098 10
			544 0110 10
			FB 7PK1795
			FB 7PK1835
			538 0374 10
			420 0063 10
			428 0185 10
			428 0186 10
			821 0490 10
			821 0822 10
			821 0489 10
			821 0821 10
			713 6442 90
			713 6441 40
			771 0561 30
			772 0230 30

FAG





















































































































































































			624 3476 09
			624 3476 34
			530 0198 10
			531 0548 10
			532 0313 20
			529 0428 10
			529 0437 10
			532 0364 20
			532 0534 10
			534 0181 10
			534 0317 10
			535 0081 10
			544 0098 10
			544 0110 10
			FB 7PK1795
			FB 7PK1835
			538 0374 10
			420 0063 10
			428 0185 10
			428 0186 10
			821 0490 10
			821 0822 10
			821 0489 10
			821 0821 10
			713 6442 90
			713 6441 40
			771 0561 30
			772 0230 30



































































































			SCHAEFFLER
--	---	--	-------------------

RENAULT

TRAFIC II Box (FL)																								
2.5 dCi 145 (FL0J) FAG G9U 630; (107kW)	08.06-	FAG	<table border="1"> <tr><td></td><td>REP</td><td>815 0068 30</td></tr> <tr><td></td><td></td><td>818 0207 10</td></tr> <tr><td></td><td></td><td>825 0260 10</td></tr> <tr><td></td><td></td><td>825 0261 10</td></tr> <tr><td></td><td></td><td>840 0274 10</td></tr> <tr><td></td><td></td><td>840 0880 10</td></tr> <tr><td></td><td></td><td>840 0879 10</td></tr> </table>		REP	815 0068 30			818 0207 10			825 0260 10			825 0261 10			840 0274 10			840 0880 10			840 0879 10
	REP	815 0068 30																						
		818 0207 10																						
		825 0260 10																						
		825 0261 10																						
		840 0274 10																						
		840 0880 10																						
		840 0879 10																						

TRAFIC II Bus (JL)																																																																																																												
1.9 dCi FAG F9Q 762; (59kW)	04.01-07.03	LUK	<table border="1"> <tr><td>→01.03</td><td></td><td>624 3087 09</td></tr> <tr><td>→01.03; PK5.0##</td><td></td><td>624 3087 33</td></tr> <tr><td>→01.03; PK5.3##</td><td></td><td>624 3087 34</td></tr> <tr><td>02.03→</td><td></td><td>624 3312 09</td></tr> <tr><td>02.03→; PK5.0##</td><td></td><td>624 3312 33</td></tr> <tr><td>02.03→; PK5.3##</td><td></td><td>624 3312 34</td></tr> <tr><td></td><td></td><td>530 0196 10</td></tr> <tr><td></td><td></td><td>530 0196 30</td></tr> <tr><td></td><td></td><td>533 0087 20</td></tr> <tr><td>; + ; →03.02; A/C</td><td></td><td>529 0118 10</td></tr> <tr><td>; 03.02→; A/C</td><td></td><td>529 0124 10</td></tr> <tr><td>; A/C</td><td></td><td>529 0427 10</td></tr> <tr><td>; →03.02; A/C</td><td></td><td>532 0243 10</td></tr> <tr><td>; A/C</td><td></td><td>534 0142 30</td></tr> <tr><td># F-560843.XX F-556602.XX F-229643.XX</td><td></td><td>535 0030 10</td></tr> <tr><td># F-234637.XX</td><td></td><td>535 0048 10</td></tr> <tr><td>OPTION</td><td></td><td>544 0089 10</td></tr> <tr><td>; A/C</td><td></td><td>FB 6PK1795</td></tr> <tr><td>; A/C; PTO</td><td></td><td>FB 6PK1830</td></tr> <tr><td></td><td></td><td>538 0392 10</td></tr> <tr><td>FAG  right</td><td></td><td>821 0490 10</td></tr> <tr><td>FAG  left</td><td></td><td>821 0489 10</td></tr> <tr><td>FAG ; ABS; →11.02</td><td></td><td>713 6441 20</td></tr> <tr><td> 86 mm</td><td></td><td>Set</td></tr> <tr><td>FAG ; ABS; →11.02</td><td></td><td>713 6441 30</td></tr> <tr><td> 86 mm</td><td></td><td>Set</td></tr> <tr><td>FAG ; 11.02→</td><td></td><td>713 6442 90</td></tr> <tr><td> 88 mm</td><td></td><td>Set</td></tr> <tr><td> 68 mm</td><td></td><td>713 6441 40</td></tr> <tr><td>FAG </td><td></td><td>814 0135 10</td></tr> <tr><td>FAG </td><td></td><td>818 0207 10</td></tr> <tr><td>FAG </td><td></td><td>825 0260 10</td></tr> <tr><td>FAG </td><td></td><td>840 0274 10</td></tr> <tr><td>FAG </td><td></td><td>840 0880 10</td></tr> <tr><td>FAG </td><td></td><td>840 0879 10</td></tr> </table>	→01.03		624 3087 09	→01.03; PK5.0##		624 3087 33	→01.03; PK5.3##		624 3087 34	02.03→		624 3312 09	02.03→; PK5.0##		624 3312 33	02.03→; PK5.3##		624 3312 34			530 0196 10			530 0196 30			533 0087 20	 ; +  ; →03.02; A/C		529 0118 10	 ; 03.02→; A/C		529 0124 10	 ; A/C		529 0427 10	 ; →03.02; A/C		532 0243 10	 ; A/C		534 0142 30	 # F-560843.XX F-556602.XX F-229643.XX		535 0030 10	 # F-234637.XX		535 0048 10	OPTION		544 0089 10	 ; A/C		FB 6PK1795	 ; A/C; PTO		FB 6PK1830			538 0392 10	FAG  right		821 0490 10	FAG  left		821 0489 10	FAG  ; ABS; →11.02		713 6441 20	 86 mm		Set	FAG  ; ABS; →11.02		713 6441 30	 86 mm		Set	FAG  ; 11.02→		713 6442 90	 88 mm		Set	 68 mm		713 6441 40	FAG 		814 0135 10	FAG 		818 0207 10	FAG 		825 0260 10	FAG 		840 0274 10	FAG 		840 0880 10	FAG 		840 0879 10
→01.03		624 3087 09																																																																																																										
→01.03; PK5.0##		624 3087 33																																																																																																										
→01.03; PK5.3##		624 3087 34																																																																																																										
02.03→		624 3312 09																																																																																																										
02.03→; PK5.0##		624 3312 33																																																																																																										
02.03→; PK5.3##		624 3312 34																																																																																																										
		530 0196 10																																																																																																										
		530 0196 30																																																																																																										
		533 0087 20																																																																																																										
 ; +  ; →03.02; A/C		529 0118 10																																																																																																										
 ; 03.02→; A/C		529 0124 10																																																																																																										
 ; A/C		529 0427 10																																																																																																										
 ; →03.02; A/C		532 0243 10																																																																																																										
 ; A/C		534 0142 30																																																																																																										
 # F-560843.XX F-556602.XX F-229643.XX		535 0030 10																																																																																																										
 # F-234637.XX		535 0048 10																																																																																																										
OPTION		544 0089 10																																																																																																										
 ; A/C		FB 6PK1795																																																																																																										
 ; A/C; PTO		FB 6PK1830																																																																																																										
		538 0392 10																																																																																																										
FAG  right		821 0490 10																																																																																																										
FAG  left		821 0489 10																																																																																																										
FAG  ; ABS; →11.02		713 6441 20																																																																																																										
 86 mm		Set																																																																																																										
FAG  ; ABS; →11.02		713 6441 30																																																																																																										
 86 mm		Set																																																																																																										
FAG  ; 11.02→		713 6442 90																																																																																																										
 88 mm		Set																																																																																																										
 68 mm		713 6441 40																																																																																																										
FAG 		814 0135 10																																																																																																										
FAG 		818 0207 10																																																																																																										
FAG 		825 0260 10																																																																																																										
FAG 		840 0274 10																																																																																																										
FAG 		840 0880 10																																																																																																										
FAG 		840 0879 10																																																																																																										



1.9 dCi 80 (JL0B) FAG F9Q 762; (60kW)	03.01-	LUK	<table border="1"> <tr><td>G5;  PK5.011</td><td>GearBOX</td><td>462 0155 10</td></tr> <tr><td>G6;  PK6.011</td><td></td><td></td></tr> <tr><td>G6;  PK6.363</td><td>GearBOX</td><td>462 0203 10</td></tr> <tr><td>→01.03</td><td></td><td>624 3087 09</td></tr> <tr><td>→01.03; PK5.0##</td><td></td><td>624 3087 33</td></tr> <tr><td>→01.03; PK5.3##</td><td></td><td>624 3087 34</td></tr> <tr><td>02.03→</td><td></td><td>624 3312 09</td></tr> <tr><td>02.03→; PK5.0##</td><td></td><td>624 3312 33</td></tr> <tr><td>02.03→; PK5.3##</td><td></td><td>624 3312 34</td></tr> <tr><td></td><td></td><td>530 0196 10</td></tr> <tr><td></td><td></td><td>530 0196 30</td></tr> <tr><td></td><td></td><td>533 0087 20</td></tr> <tr><td>; + ; A/C</td><td></td><td>529 0118 10</td></tr> <tr><td>; 03.02→07.06; A/C</td><td></td><td>529 0124 10</td></tr> <tr><td>; →07.06; A/C</td><td></td><td>529 0427 10</td></tr> <tr><td>; →03.02; A/C</td><td></td><td>532 0243 10</td></tr> <tr><td>; A/C; →07.06</td><td></td><td>534 0142 30</td></tr> <tr><td>; A/C</td><td></td><td>534 0240 10</td></tr> <tr><td># F-560843.XX F-556602.XX F-229643.XX</td><td></td><td>535 0030 10</td></tr> <tr><td># F-234637.XX</td><td></td><td>535 0048 10</td></tr> <tr><td>OPTION</td><td></td><td>544 0089 10</td></tr> <tr><td>A/C</td><td></td><td>544 0101 10</td></tr> <tr><td>A/C</td><td></td><td>544 0101 20</td></tr> </table>	G5 ;  PK5.011	GearBOX	462 0155 10	G6 ;  PK6.011			G6 ;  PK6.363	GearBOX	462 0203 10	→01.03		624 3087 09	→01.03; PK5.0##		624 3087 33	→01.03; PK5.3##		624 3087 34	02.03→		624 3312 09	02.03→; PK5.0##		624 3312 33	02.03→; PK5.3##		624 3312 34			530 0196 10			530 0196 30			533 0087 20	 ; +  ; A/C		529 0118 10	 ; 03.02→07.06; A/C		529 0124 10	 ; →07.06; A/C		529 0427 10	 ; →03.02; A/C		532 0243 10	 ; A/C; →07.06		534 0142 30	 ; A/C		534 0240 10	 # F-560843.XX F-556602.XX F-229643.XX		535 0030 10	 # F-234637.XX		535 0048 10	OPTION		544 0089 10	A/C		544 0101 10	A/C		544 0101 20
G5 ;  PK5.011	GearBOX	462 0155 10																																																																						
G6 ;  PK6.011																																																																								
G6 ;  PK6.363	GearBOX	462 0203 10																																																																						
→01.03		624 3087 09																																																																						
→01.03; PK5.0##		624 3087 33																																																																						
→01.03; PK5.3##		624 3087 34																																																																						
02.03→		624 3312 09																																																																						
02.03→; PK5.0##		624 3312 33																																																																						
02.03→; PK5.3##		624 3312 34																																																																						
		530 0196 10																																																																						
		530 0196 30																																																																						
		533 0087 20																																																																						
 ; +  ; A/C		529 0118 10																																																																						
 ; 03.02→07.06; A/C		529 0124 10																																																																						
 ; →07.06; A/C		529 0427 10																																																																						
 ; →03.02; A/C		532 0243 10																																																																						
 ; A/C; →07.06		534 0142 30																																																																						
 ; A/C		534 0240 10																																																																						
 # F-560843.XX F-556602.XX F-229643.XX		535 0030 10																																																																						
 # F-234637.XX		535 0048 10																																																																						
OPTION		544 0089 10																																																																						
A/C		544 0101 10																																																																						
A/C		544 0101 20																																																																						



			<p>SCHAEFFLER</p>
--	--	--	--------------------------

RENAULT





































































































TRAFIC II Bus (JL)

<p>1.9 dCI 80 (JLOB) F9Q 762; (60kW)</p>	<p>03.01-</p>	<p></p>	<p> 11.01; A/C 11.01; A/C; PTO 1x right; →11.06 right; 12.06→ left; →11.06 left; 12.06→ ABS; →11.02 86 mm ABS; →11.02 86 mm ; 11.02→ 88 mm 68 mm ↔ ; 12.06→ right left </p>	<p> FB 6PK1795 FB 6PK1830 538 0392 10 OILP 553 0124 10 821 0490 10 821 0822 10 821 0489 10 821 0821 10 Set 713 6441 20 Set 713 6441 30 Set 713 6442 90 Set 713 6441 40 771 0507 30 REP 815 0068 30 818 0207 10 825 0260 10 825 0261 10 840 0274 10 840 0880 10 840 0879 10 </p>
<p>1.9 dCI 100 (JLOC) F9Q 760; (74kW)</p>	<p>03.01-</p>	<p></p> <p></p>	<p> G6; PK6.073 →01.03 →01.03; PK6.0## →01.03; PK6.3## 02.03→ 02.03→; PK6.0## 02.03→; PK6.3## + ; →03.02; A/C ; →07.06; A/C ; →07.06; A/C; e ; →03.02; A/C ; 03.02→07.06 ; A/C; →07.06 ; A/C # F-560843.XX F-556602.XX F-229643.XX # F-234637.XX OPTION ; →07.06; A/C ; A/C ; A/C; PTO ; →07.06; A/C; e right; →11.06 right; 12.06→ left; →11.06 left; 12.06→ ABS; →11.02 86 mm ABS; →11.02 86 mm ; 11.02→ 88 mm 68 mm ↔ ; 12.06→ right </p>	<p> GearBOX 462 0155 10 624 3087 09 624 3087 33 624 3087 34 624 3312 09 624 3312 33 624 3312 34 530 0196 10 530 0196 30 533 0087 20 529 0118 10 529 0124 10 529 0427 10 532 0243 10 532 0364 20 534 0142 30 534 0240 10 535 0030 10 535 0048 10 544 0089 10 FB 5PK1125 FB 6PK1795 FB 6PK1830 FB 6PK1835 538 0392 10 821 0490 10 821 0822 10 821 0489 10 821 0821 10 Set 713 6441 20 Set 713 6441 30 Set 713 6442 90 Set 713 6441 40 771 0507 30 REP 815 0068 30 818 0207 10 825 0260 10 825 0261 10 840 0274 10 840 0880 10 </p>



			SCHAEFFLER
--	---	--	-------------------

RENAULT





































































































































































TRAFIC II Bus (JL)								
1.9 dCi 100 (JLOC) F9Q 760; (74kW)	03.01-	FAG	 left  840 0879 10					
2.0 dCi 115 (JLOH) 2.0 dCi 90 (JLOH) M9R 630; M9R 692; M9R 780; M9R 782; M9R 786; (66-84kW)	08.06-	LUK	 PF6.0##  624 3476 09  624 3476 34  529 0317 10  535 0080 10  FB 7PK1741  FB 7PK1973  538 0397 10  420 0086 10					
			 F-236675.XX F-561464.XX  ; A/C  ; A/C 16x  12 mm 16x  422 0078 10 1x  558 0059 10 1x  559 0171 10 1x  559 0171 30					
		FAG	 right; →11.06  right; 12.06→  left; →11.06  left; 12.06→  88 mm  68 mm  ; ←  left ←; 03.13→; G5  ↔  ↔  ; 12.06→  right  left	 821 0490 10  821 0822 10  821 0489 10  821 0821 10  713 6442 90  713 6441 40  771 0561 30  772 0230 30  815 0068 30  818 0207 10  825 0260 10  825 0261 10  840 0274 10  840 0880 10  840 0879 10				
		2.0 16V F4R 820; (86kW)	08.06-	LUK	G6 ;  PK6.372 PK6.384 PK6.385 GearBOX 462 0203 10  624 3092 33			
					 ; A/C  ; A/C  # F-560843.XX F-556602.XX F-229643.XX  # F-234637.XX 16x  12 mm 16x  422 0009 10			
				FAG	 right; →11.06  right; 12.06→  left; →11.06  left; 12.06→  88 mm  68 mm  ; ←  ↔  ↔  ; 12.06→  right  left	 821 0490 10  821 0822 10  821 0489 10  821 0821 10  713 6442 90  713 6441 40  771 0507 30  814 0135 10  818 0207 10  825 0260 10  825 0261 10  840 0274 10  840 0880 10  840 0879 10		
				2.0 (JLOA) F4R 720; F4R 722; (88kW)	03.01-	LUK	G6 ;  PK6.009 G6 ;  PK6.372 GearBOX 462 0155 10 GearBOX 462 0203 10  624 3092 09  624 3092 33  624 3092 34	
							 ; A/C  ; A/C  ; →02.09;  F4R 720; A/C  # F-560843.XX F-556602.XX F-229643.XX  # F-234637.XX	 529 0124 10  529 0427 10  534 0240 10  535 0030 10  535 0048 10



			SCHAEFFLER
--	--	--	-------------------

RENAULT

TRAFIC II Bus (JL)



















































































































<p>2.0 (JL0A)  F4R 720; F4R 722; (88kW)</p>	<p>03.01-</p>	<p></p>	<p>16x  12 mm</p> <p>16x  right; →11.06  right; 12.06→  left; →11.06  left; 12.06→  ; ABS ; →11.02  86 mm  ; ABS ; →11.02  86 mm  ; 11.02→  88 mm  68 mm  68 mm  68 mm  68 mm  68 mm  68 mm  68 mm  68 mm  68 mm  68 mm  68 mm  68 mm  68 mm  68 mm  68 mm  68 mm  68 mm  68 mm  68 mm  68 mm  68 mm  68 mm  68 mm  68 mm  68 mm  68 mm  68 mm  68 mm  68 mm  68 mm  68 mm  68 mm  68 mm  68 mm  68 mm  68 mm  68 mm  68 mm  68 mm  68 mm  68 mm  68 mm  68 mm  68 mm</p>	<p> 538 0392 10  420 0099 10  422 0009 10  821 0490 10  821 0822 10  821 0489 10  821 0821 10   713 6441 20   713 6441 30   713 6442 90   713 6441 40  771 0507 30   815 0068 30  818 0207 10  825 0260 10  825 0261 10  840 0274 10  840 0880 10  840 0879 10</p>
<p>2.5 dCi 115  G9U 630; (84kW)</p>	<p>02.08-</p>	<p></p> <p></p>	<p>PF6.0##</p> <p> 11 mm</p> <p> 11 mm</p> <p> 11 mm</p> <p> 11 mm</p> <p> 11 mm</p> <p> 11 mm</p> <p> 11 mm</p> <p> 11 mm</p> <p> 11 mm</p> <p> 11 mm</p> <p> 11 mm</p> <p> 11 mm</p> <p> 11 mm</p> <p> 11 mm</p> <p> 11 mm</p> <p> 11 mm</p> <p> 11 mm</p> <p> 11 mm</p> <p> 11 mm</p> <p> 11 mm</p> <p> 11 mm</p> <p> 11 mm</p> <p> 11 mm</p> <p> 11 mm</p> <p> 11 mm</p> <p> 11 mm</p> <p> 11 mm</p> <p> 11 mm</p> <p> 11 mm</p> <p> 11 mm</p> <p> 11 mm</p> <p> 11 mm</p> <p> 11 mm</p> <p> 11 mm</p> <p> 11 mm</p> <p> 11 mm</p> <p> 11 mm</p>	<p> 624 3476 09  624 3476 34  530 0198 10  531 0548 10  532 0313 20  529 0428 10  529 0437 10  532 0364 20  532 0534 10  534 0181 10  534 0317 10  544 0110 10  FB 7PK1795  FB 7PK1835  538 0374 10  420 0063 10  428 0185 10  428 0186 10  821 0822 10  821 0821 10   713 6442 90   713 6441 40   772 0230 30  814 0135 10  818 0207 10  825 0261 10  840 0274 10  840 0880 10  840 0879 10</p>
<p>2.5 dCi 135 (JL0D)  G9U 730; (99kW)</p>	<p>05.03-</p>	<p></p>	<p>→06.04;  PK6.0## incl.  ; incl.  ; SAC</p> <p>→06.04 SAC</p> <p>→06.04;  PK6.3## SAC</p> <p>→06.04;  PK6.0## SAC</p> <p>07.04→</p>	<p> 600 0078 00  623 3159 09  623 3159 33  623 3159 34  624 3945 09</p>



			SCHAEFFLER
--	---	--	-------------------

RENAULT

TRAFIC II Bus (JL)

























2.5 dCi 135 (JL0D) G9U 730; (99kW)	05.03-	  	07.04→; PK6.3##		624 3945 33
			07.04→; PK6.0##		624 3945 34
			→06.04		415 0146 10
			incl. 		
					530 0198 10
					531 0548 10
			 ; →07.06; A/C; e; # OE 6PK1835		532 0313 20
			 ; →07.06		529 0436 10
			 ; →07.06; A/C		532 0364 20
			 ; →07.06; A/C; e		534 0181 10
			 ; →07.06; A/C; e		534 0317 10
			 # F-560843.XX F-556602.XX F-229643.XX		535 0030 10
			+ ACC		544 0094 10
			A/C e		
			 ; A/C		FB 6PK1153
			 ; A/C		FB 6PK1795
			 ; →07.06; A/C		FB 6PK1835
			 ; →07.06; A/C; e		FB 6PK1835
					538 0374 10
			16x		420 0063 10
			 11 mm		
			1x; 		428 0185 10
			1x; 		428 0186 10
		FAG	 right; →11.06		821 0490 10
			 right; 12.06→		821 0822 10
			 left; →11.06		821 0489 10
			 left; 12.06→		821 0821 10
					713 6442 90
			 88 mm		713 6441 40
			 68 mm		815 0068 30
					818 0207 10
			 ↔		825 0260 10
			 ; 12.06→		825 0261 10
					840 0274 10
			 right		840 0880 10
			 left		840 0879 10
					624 3476 09
2.5 dCi 145 (JL0J) G9U 630; (107kW)	08.06-		  	PF6.0##	
					530 0198 10
					531 0548 10
					532 0313 20
			 ; A/C; e		529 0428 10
			 ; A/C; # OE 7PK1835		529 0437 10
			 ; A/C; e; # OE 7PK1835		
			 ; →09.10; A/C		532 0364 20
			 ; →09.10; A/C e		532 0364 20
			 ; 09.10→; A/C		532 0534 10
			 ; 09.10→; A/C e		534 0181 10
			 ; A/C		534 0181 10
			 ; A/C; e		534 0317 10
			 ; A/C; e		534 0317 10
			 # F-238512.XX		535 0081 10
					544 0098 10
			 ; OPTION		544 0110 10
			 ; A/C; PTO; # OE 8200833558		FB 7PK1795
			 ; A/C		
			 ; A/C; e		FB 7PK1835
					538 0374 10
			16x		420 0063 10
			 11 mm		
			1x; 		428 0185 10
			1x; 		428 0186 10
		FAG	 right; →11.06		821 0490 10
			 right; 12.06→		821 0822 10
			 left; →11.06		821 0489 10
			 left; 12.06→		821 0821 10































































			<p>SCHAEFFLER</p>
--	--	--	--------------------------





























RENAULT

TRAFIC II Bus (JL)

<p>2.5 dCi 145 (JL0J) F9U 630; (107kW)</p>	<p>08.06-</p>	<p>FAG</p> <ul style="list-style-type: none">  88 mm  68 mm  ;   left  ; 03.13  →; G5   ↔   ; 12.06 →   right  left 	<ul style="list-style-type: none">  Set 713 6442 90  Set 713 6441 40  771 0561 30  SET 772 0230 30  REP 815 0068 30  818 0207 10  825 0260 10  825 0261 10  840 0274 10  840 0880 10  840 0879 10
--	---------------	--	---

TRAFIC II Platform/Chassis (EL)

<p>1.9 dCi F9Q 762; (59kW)</p>	<p>09.01-07.03</p>	<p>LUK</p> <ul style="list-style-type: none"> G6 ;  PK6.363 →01.03 →01.03;  PK5.0## →01.03;  PK5.3## 02.03 → 02.03 →;  PK5.0## 02.03 →;  PK5.3## <p></p> <ul style="list-style-type: none">   ; +  ; →03.02; A/C  ; A/C  ; A/C  ; →03.02; A/C  # F-560843.XX F-556602.XX F-229643.XX  # F-234637.XX OPTION  ; A/C ; PTO <p>FAG</p> <ul style="list-style-type: none">  right  left  ; ABS ; →11.02  86 mm  ; ABS ; →11.02  86 mm  ; 11.02 →  88 mm   68 mm   ↔    right  left 	<ul style="list-style-type: none"> GearBOX 462 0203 10  624 3087 09  624 3087 33  624 3087 34  624 3312 09  624 3312 33  624 3312 34  530 0196 10  533 0087 20  529 0118 10  529 0124 10  529 0427 10  532 0243 10  535 0030 10  535 0048 10  544 0089 10  FB 6PK1830  538 0392 10  821 0490 10  821 0489 10  Set 713 6441 20  Set 713 6441 30  Set 713 6442 90  Set 713 6441 40  814 0135 10  818 0207 10  825 0260 10  840 0274 10  840 0880 10  840 0879 10
------------------------------------	--------------------	--	--

<p>1.9 dCi 80 (EL0B) F9Q 762; (60kW)</p>	<p>03.01-</p>	<p>LUK</p> <ul style="list-style-type: none"> G5 ;  PK5.013 G6 ;  PK6.013 →04.07; G5 ;  PK5.363 04.07 →; G5 ;  PK5.363 →01.03 →01.03;  PK5.0## →01.03;  PK5.3## 02.03 → 02.03 →;  PK5.0## 02.03 →;  PK5.3## <p></p> <ul style="list-style-type: none">   ; +  ; →03.02; A/C  ; →07.06; A/C  ; →07.06; A/C  ; →03.02; A/C  ; A/C  # F-560843.XX F-556602.XX F-229643.XX 	<ul style="list-style-type: none"> GearBOX 462 0155 10 GearBOX 462 0203 10 GearBOX 462 0231 10  624 3087 09  624 3087 33  624 3087 34  624 3312 09  624 3312 33  624 3312 34  530 0196 10  530 0196 30  533 0087 20  529 0118 10  529 0124 10  529 0427 10 532 0243 10 534 0240 10 535 0030 10
--	---------------	--	---





SCHAEFFLER



RENAULT

TRAFIC II Platform/Chassis (EL)

1.9 dCi 80 (ELOB)
F9Q 762; (60kW)

03.01-



№# F-234637.XX

OPTION

A/C

A/C

A/C

A/C ; PTO

1x

FAG

right; →11.06

right; 12.06→

left; →11.06

left; 12.06→

ABS ; →11.02

86 mm

ABS ; →11.02

86 mm

11.02→

88 mm

68 mm

771 0507 30

REP

815 0068 30

818 0207 10

825 0260 10

12.06→

825 0261 10

840 0274 10

right

840 0880 10

left

840 0879 10



→01.03

→01.03; PK6.0##

→01.03; PK6.3##

02.03→

02.03→; PK6.0##

02.03→; PK6.3##



530 0196 10

530 0196 30

533 0087 20

A/C ; + ; →03.02; A/C

09.01→07.06; A/C

09.01→07.06; A/C ;

→03.02; A/C

03.02→07.06; A/C

09.01→07.06; A/C

A/C

534 0142 30

534 0240 10

№# F-560843.XX F-556602.XX F-229643.XX

№# F-234637.XX

OPTION

A/C

A/C

A/C

A/C ; PTO

09.01→07.06; A/C

09.01→07.06; A/C ;

538 0392 10

FAG

right; →11.06

right; 12.06→

left; →11.06

left; 12.06→

ABS ; →11.02

86 mm

ABS ; →11.02

86 mm

11.02→

88 mm

68 mm

771 0507 30

1.9 dCi 100 (ELOC)
F9Q 760; (74kW)















































































03.01-



			SCHAEFFLER
--	--	--	-------------------

RENAULT

TRAFIC II Platform/Chassis (EL)





























































































































1.9 dCi 100 (ELOC) M9Q 760; (74kW)	03.01-	FAG	 		815 0068 30
			 ↔		818 0207 10
					825 0260 10
			 ; 12.06 →		825 0261 10
			 right		840 0274 10
			 left		840 0880 10
					840 0879 10
					624 3476 09
					624 3476 34
			2.0 dCi 90 (ELOH) M9R 780; M9R 782; (66kW)	08.06-	LUK
 # F-236675.XX F-561464.XX		535 0080 10			
 ; A/C		FB 7PK1741			
 ; A/C		FB 7PK1973			
		538 0397 10			
		420 0086 10			
16x					
 12 mm					
16x		422 0078 10			
1x		558 0059 10			
1x		559 0171 10			
1x		559 0171 30			
FAG	 right; →11.06				821 0490 10
	 right; 12.06 →				821 0822 10
	 left; →11.06				821 0489 10
	 left; 12.06 →				821 0821 10
					713 6442 90
	 88 mm				
					713 6441 40
	 ; 				771 0561 30
	 left  ; 03.13 →; G6		772 0230 30		
			815 0068 30		
 ↔		818 0207 10			
		825 0260 10			
 ; 12.06 →		825 0261 10			
		840 0274 10			
 right		840 0880 10			
 left		840 0879 10			
2.0 dCi 115 (ELOH) M9R 692; M9R 780; M9R 782; M9R 786; (84kW)	08.06-	LUK			624 3476 09
					624 3476 34
			 # F-236675.XX F-561464.XX		529 0317 10
			 ; A/C		535 0080 10
			 ; A/C		FB 7PK1741
					FB 7PK1973
					538 0397 10
					420 0086 10
			16x		
			 12 mm		
		16x		422 0078 10	
		1x		558 0059 10	
		1x		559 0171 10	
		1x		559 0171 30	
		FAG	right; →11.06		821 0490 10
			right; 12.06 →		821 0822 10
			left; →11.06		821 0489 10
			left; 12.06 →		821 0821 10
					713 6442 90
			88 mm		
			713 6441 40		
;			771 0561 30		
left ; 03.13 →; G5			772 0230 30		
			815 0068 30		
↔		818 0207 10			
		825 0260 10			
; 12.06 →		825 0261 10			
		840 0274 10			
right		840 0880 10			
left		840 0879 10			
2.0 16V F4R 820; (86kW)	08.06-	LUK			624 3092 09



			SCHAEFFLER
--	---	--	-------------------

RENAULT

TRAFIC II Platform/Chassis (EL)

2.0 16V F4R 820; (86kW)	08.06-		 PK6.3##	 624 3092 33		
			 PK6.0##	 624 3092 34		
				 A/C	 529 0124 10	
					 A/C	 529 0427 10
					16x	 420 0099 10
					 12 mm	
					16x	 422 0009 10
				 right; 12.06→	 821 0822 10	
				 left; 12.06→	 821 0821 10	
					 Set 713 6442 90	
				 88 mm	 Set 713 6441 40	
				 68 mm	 Set 713 6441 40	
					 814 0135 10	
				 ↔	 818 0207 10	
				 ; 12.06→	 825 0261 10	
			 840 0274 10			
	 right		 840 0880 10			
	 left		 840 0879 10			
2.0 (ELOA) F4R 720; (88kW)	03.01-			G6 ;  PK6.009	GearBOX 462 0155 10	
		G6 ;  PK6.372		GearBOX 462 0203 10		
				 624 3092 09		
			 PK6.3##	 624 3092 33		
			 PK6.0##	 624 3092 34		
				 ; 09.01→07.06; A/C	 529 0124 10	
				 ; 09.01→07.06; A/C	 529 0427 10	
				 ; →02.09; A/C	 534 0240 10	
				 # F-560843.XX	 535 0030 10	
				 # F-556602.XX	 535 0048 10	
				 # F-229643.XX	 FB 6PK1795	
				 ; A/C	 538 0392 10	
				16x	 420 0099 10	
				 12 mm		
				16x	 422 0009 10	
				 right; →11.06	 821 0490 10	
				 right; 12.06→	 821 0822 10	
				 left; →11.06	 821 0489 10	
				 left; 12.06→	 821 0821 10	
				 ; ABS ; →11.02	 Set 713 6441 20	
				 86 mm	 Set 713 6441 30	
				 ; ABS ; →11.02	 Set 713 6441 30	
				 86 mm	 Set 713 6442 90	
				 ; 11.02→	 Set 713 6442 90	
	 88 mm		 Set 713 6441 40			
	 68 mm		 Set 713 6441 40			
			 771 0507 30			
			 REP 815 0068 30			
	 ↔		 818 0207 10			
	 ; 12.06→	 825 0260 10				
		 825 0261 10				
	 right	 840 0274 10				
	 left	 840 0880 10				
		 840 0879 10				
2.5 dCi G9U 630; (84kW)	08.07-		 PF6.0##	 624 3476 09		
			 PF6.0##	 624 3476 34		
					 530 0198 10	
					 531 0548 10	
					 532 0313 20	
				 ; A/C ; -e	 529 0428 10	
				 ; A/C ; # OE 7PK1835	 529 0437 10	
				 ; A/C ; e ; # OE 7PK1835		
				 ; →09.10; A/C	 532 0364 20	
				 ; →09.10; A/C e		
				 ; 09.10→; A/C	 532 0534 10	
				 ; 09.10→; A/C e		
				 ; A/C	 534 0181 10	
				 ; A/C ; e		









			<p>SCHAEFFLER</p>
--	--	--	--------------------------

RENAULT

TRAFIC II Platform/Chassis (EL)











2.5 dCi
 G9U 630; (84kW)

08.07-

	16x; A/C; -e # F-238512.XX 16x; A/C; PTO; # OE 8200833558 16x; A/C 16x; A/C; -e	534 0317 10 535 0081 10 FB 7PK1795 FB 7PK1835 538 0374 10 420 0063 10
16x  11 mm 1x;  1x; 	FAG right left  88 mm  68 mm right left right left right left right left right left right left right left	428 0185 10 428 0186 10 821 0822 10 821 0821 10 713 6442 90 713 6441 40 814 0135 10 818 0207 10 825 0260 10 825 0261 10 840 0274 10 840 0880 10 840 0879 10

2.5 dCi 135 (EL0D)
 G9U 730; (99kW)

03.01-





















































































	→06.04; PK6.0## incl.  ; incl.  ; SAC →06.04 SAC →06.04; PK6.3## SAC →06.04; PK6.0## SAC 07.04→ 07.04→; PK6.3## 07.04→; PK6.0## →06.04 incl. 	600 0078 00 623 3159 09 623 3159 33 623 3159 34 624 3945 09 624 3945 33 624 3945 34 415 0146 10
	16x; →07.06; A/C; -e; # OE 6PK1835 16x; →07.06 16x; →07.06; A/C 16x; →07.06; A/C; -e 16x; →07.06; A/C; -e # F-560843.XX F-556602.XX F-229643.XX + ACC A/C -e 16x; A/C; PTO 16x; A/C 16x; →07.06; A/C 16x; →07.06; A/C; -e 16x; →07.06; A/C; -e 16x; →07.06; A/C; -e 16x; →07.06; A/C	530 0198 10 531 0548 10 532 0313 20 529 0436 10 532 0364 20 534 0181 10 534 0317 10 535 0030 10 544 0094 10 FB 6PK1153 FB 6PK1795 FB 6PK1835 FB 6PK1835 FB 6PK1835 538 0374 10 420 0063 10
16x  11 mm 1x;  1x; 	FAG right; →11.06 right; 12.06→ left; →11.06 left; 12.06→ ABS; →11.02  86 mm ABS; →11.02  86 mm ; 11.02→  88 mm	428 0185 10 428 0186 10 821 0490 10 821 0822 10 821 0489 10 821 0821 10 713 6441 20 713 6441 30 713 6442 90























			SCHAEFFLER
--	---	--	-------------------

RENAULT

TRAFIC II Platform/Chassis (EL)

2.5 dCi 135 (EL0D) G9U 730; (99kW)	03.01-	FAG	 68 mm	 Set	713 6441 40
			 ←	 REP	815 0068 30
			 →		818 0207 10
			 ; 12.06 →		825 0260 10
					825 0261 10
					840 0274 10
			 right		840 0880 10
			 left		840 0879 10
					624 3476 09
					624 3476 34
					530 0198 10
					531 0548 10
					532 0313 20
					529 0428 10
		529 0437 10			
		532 0364 20			
		532 0534 10			
		534 0181 10			
		534 0317 10			
		535 0081 10			
		544 0110 10			
		FB 7PK1795			
		FB 7PK1835			
		538 0374 10			
		420 0063 10			
16x					
 11 mm					
1x; 		428 0185 10			
1x; 		428 0186 10			
 right; →11.06		821 0490 10			
 right; 12.06 →		821 0822 10			
 left; →11.06		821 0489 10			
 left; 12.06 →		821 0821 10			
	 Set	713 6442 90			
	 Set	713 6441 40			
		771 0561 30			
 left  ← ; 03.13 →; G5	 SET	772 0230 30			
	 REP	815 0068 30			
		818 0207 10			
		825 0260 10			
		825 0261 10			
		840 0274 10			
 right		840 0880 10			
left		840 0879 10			

TRAFIC III Box (FG_)





















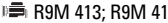





























































































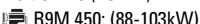















































1.6 dCi 90 (FGME) R9M 408; (66kW)	05.14-	LUK	SAC		624 3930 33
					415 0796 10
					529 0246 10
			 ;  MANU		529 0247 10
			 ; für kalte Klimazonen		532 0534 10
			 ; A/C		532 0534 10
			 ;  MANU		534 0624 10
					535 0080 10
					535 0081 10
					535 0153 10
					FB 7PK1325
					FB 7PK1675
					FB 7PK1685
					538 0399 10
			16x		420 0086 10
			12 mm		
			16x		422 0078 10

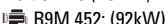

			SCHAEFFLER
--	--	--	-------------------

RENAULT

TRAFIC III Box (FG_)

























































1.6 dCi 90 (FGME)  R9M 408; (66kW)	05.14-	FAG	  713 6451 90
			 ↔  818 0207 10
			 right  840 0274 10
			 left  840 0880 10
			 left  840 0879 10
1.6 dCi 95 (FGMJ, FGMR)  R9M 413; R9M 415; (70kW)	07.15-	LUK	SAC  624 3930 33
			  415 0796 10
			  529 0246 10
		  für kalte Klimazonen  529 0247 10	
		  A/C  532 0534 10	
		  MANU  534 0624 10	
		  # F-236675.XX F-561464.XX  535 0080 10	
		  # F-238512.XX  535 0081 10	
		  # F-552305.XX  535 0153 10	
		  A/C ; für kalte Klimazonen  FB 7PK1675	
		   FB 7PK1685	
		  538 0399 10	
		FAG	  713 6451 90
			 ↔  840 0274 10
			 right  840 0880 10
 left  840 0879 10			
 left  840 0879 10			
1.6 dCi 115 (FGMD)  R9M 408; (85kW)	05.14-	LUK	SAC  624 3930 33
			  415 0796 10
			  529 0246 10
		  für kalte Klimazonen  529 0247 10	
		  A/C  532 0534 10	
		  MANU  534 0624 10	
		  # F-236675.XX F-561464.XX  535 0080 10	
		  # F-238512.XX  535 0081 10	
		  # F-552305.XX  535 0153 10	
		  A/C  FB 7PK1325	
		  A/C ; für kalte Klimazonen  FB 7PK1675	
		   FB 7PK1685	
		  538 0399 10	
		  16x  420 0086 10	
		  12 mm	
  16x  422 0078 10			
FAG	  713 6451 90		
	 ↔  818 0207 10		
	 right  840 0274 10		
	 left  840 0880 10		
	 left  840 0879 10		
1.6 dCi 120 (FGMB) 1.6 dCi 140 (FGMA)  R9M 450; (88-103kW)	05.14-	LUK	SAC  624 3930 33
			  415 0796 10
			  529 0246 10
		  für kalte Klimazonen  529 0247 10	
		  A/C  532 0534 10	
		  MANU  534 0624 10	
		  # F-236675.XX F-561464.XX  535 0080 10	
		  # F-238512.XX  535 0081 10	
		  # F-552305.XX  535 0153 10	
		  A/C  FB 7PK1325	
		  A/C  FB 7PK1675	
		   FB 7PK1685	
		  538 0399 10	
		  16x  420 0086 10	
		  12 mm	
  16x  422 0078 10			
FAG	  713 6451 90		
	 ↔  818 0207 10		
	 right  840 0274 10		
	 left  840 0880 10		
	 left  840 0879 10		
1.6 dCi 125 (FGMH)  R9M 452; (92kW)	07.15-	LUK	SAC  624 3930 33
			  415 0796 10
			  529 0246 10





























































			SCHAEFFLER
--	---	--	-------------------

RENAULT

TRAFIC III Box (FG_)

1.6 dCi 125 (FGMH) R9M 452; (92kW)	07.15-		 ;  MANU		529 0246 10
			 ; für kalte Klimazonen		529 0247 10
					532 0534 10
			 ;  MANU		534 0624 10
			⊞# F-236675.XX F-561464.XX		535 0080 10
			⊞# F-238512.XX		535 0081 10
			⊞# F-552305.XX		535 0153 10
			 ; A/C ; für kalte Klimazonen		FB 7PK1675
					FB 7PK1685
					538 0399 10
			FAG		Set 713 6451 90
					818 0207 10
					840 0274 10
			 right		840 0880 10
 left		840 0879 10			
1.6 dCi 145 (FGMG) R9M 452; (107kW)	07.15-		SAC		624 3930 33
					415 0796 10
			 ;  MANU		529 0246 10
			 ; für kalte Klimazonen		529 0247 10
					532 0534 10
			 ;  MANU		534 0624 10
			⊞# F-236675.XX F-561464.XX		535 0080 10
			⊞# F-238512.XX		535 0081 10
			⊞# F-552305.XX		535 0153 10
			 ; A/C ; für kalte Klimazonen		FB 7PK1675
					FB 7PK1685
					538 0399 10
			FAG		Set 713 6451 90
					840 0274 10
 right		840 0880 10			
 left		840 0879 10			

TRAFIC III Bus (JG_)





















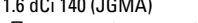





























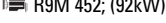



























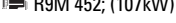



















1.6 dCi 115 (JGMD) 1.6 dCi 90 (JGME) R9M 408; (66-85kW)	05.14-		SAC		624 3930 33
					415 0796 10
			 ;  MANU		529 0246 10
			 ; für kalte Klimazonen		529 0247 10
			 ; A/C		532 0534 10
			 ;  MANU		534 0624 10
			⊞# F-236675.XX F-561464.XX		535 0080 10
			⊞# F-238512.XX		535 0081 10
			⊞# F-552305.XX		535 0153 10
			 ; A/C		FB 7PK1325
			 ; A/C ; für kalte Klimazonen		FB 7PK1675
			 ; A/C		FB 7PK1685
					538 0399 10
			16x  12 mm		420 0086 10
16x		422 0078 10			
FAG		Set 713 6451 90			
		818 0207 10			
		840 0274 10			
 right		840 0880 10			
 left		840 0879 10			
1.6 dCi 95 (JGMR, JGMJ) R9M 413; R9M 415; (70kW)	07.15-		SAC		624 3930 33
					415 0796 10
			 ;  MANU		529 0246 10
			 ; für kalte Klimazonen		529 0247 10
			 ; A/C		532 0534 10
			 ;  MANU		534 0624 10
			⊞# F-236675.XX F-561464.XX		535 0080 10
			⊞# F-238512.XX		535 0081 10
			⊞# F-552305.XX		535 0153 10
			 ; A/C		FB 7PK1325
			 ; A/C ; für kalte Klimazonen		FB 7PK1675
			 ; A/C		FB 7PK1685
					538 0399 10



			<p>SCHAEFFLER</p>
--	--	--	--------------------------

RENAULT







TRAFIC III Bus (JG_)







































































<p>1.6 dCi 95 (JGMR, JGMJ) </p>	<p>07.15-</p>	<p></p>	<p>16x  12 mm 16x</p>	<p> 420 0086 10  422 0078 10  713 6451 90  818 0207 10  840 0274 10  840 0880 10  840 0879 10</p>
<p>1.6 dCi 120 (JGMB) 1.6 dCi 140 (JGMA) </p>	<p>05.14-</p>	<p></p>	<p>SAC</p>	<p> 624 3930 33  415 0796 10  <ul style="list-style-type: none">  ;  MANU  529 0246 10  ; für kalte Klimazonen  529 0247 10  ; A/C  532 0534 10  ;  MANU  534 0624 10  # F-236675.XX F-561464.XX  535 0080 10  # F-238512.XX  535 0081 10  # F-552305.XX  535 0153 10  ; A/C  FB 7PK1325   FB 7PK1675  ; A/C  FB 7PK1685  538 0399 10 16x  12 mm  420 0086 10 16x  422 0078 10 </p>
<p>1.6 dCi 125 (JGMH) </p>	<p>07.15-</p>	<p></p>	<p>SAC</p>	<p> 624 3930 33  415 0796 10  <ul style="list-style-type: none">  ;  MANU  529 0246 10  ; für kalte Klimazonen  529 0247 10   MANU  534 0624 10  # F-236675.XX F-561464.XX  535 0080 10  # R9M*  535 0081 10  # F-238512.XX  535 0153 10  # F-552305.XX  535 0153 10   FB 7PK1675   FB 7PK1685  538 0399 10 16x  12 mm  420 0086 10 16x  422 0078 10 </p>
<p>1.6 dCi 145 (JGMG) </p>	<p>07.15-</p>	<p></p>	<p>SAC</p>	<p> 624 3930 33  415 0796 10  <ul style="list-style-type: none">  ;  MANU  529 0246 10  ; für kalte Klimazonen  529 0247 10  ; A/C  532 0534 10  ;  MANU  534 0624 10  # F-236675.XX F-561464.XX  535 0080 10  # F-238512.XX  535 0081 10  # F-552305.XX  535 0153 10  ; A/C  FB 7PK1325   FB 7PK1675  ; A/C  FB 7PK1685  538 0399 10 16x  12 mm  420 0086 10 16x  422 0078 10 </p>































			SCHAEFFLER
--	---	--	-------------------

RENAULT

TRAFIC III Bus (JG_)			
1.6 dCi 145 (JGMG) R9M 452; (107kW)	07.15-	FAG	  Set 713 6451 90
			 818 0207 10
			 840 0274 10
			 right  840 0880 10
			 left  840 0879 10

TRAFIC III Platform/Chassis (EG_)					
1.6 dCi 120 (EGMB) 1.6 dCi 140 (EGMA) R9M 450; (88-103kW)	06.14-	LUK	SAC  624 3930 33		
			 415 0796 10		
			  ;  MANU  529 0246 10		
			 ; für kalte Klimazonen  529 0247 10		
			  532 0534 10		
			 ;  MANU  534 0624 10		
			 # F-236675.XX F-561464.XX  535 0080 10		
			 # F-552305.XX  535 0153 10		
			 ; A/C ; für kalte Klimazonen  FB 7PK1675		
			  FB 7PK1685		
		 16x  538 0399 10			
		 12 mm  420 0086 10			
		 16x  422 0078 10			
		FAG	  Set 713 6451 90		
			 818 0207 10		
			 840 0274 10		
			 right  840 0880 10		
			 left  840 0879 10		
		1.6 dCi 125 (EGMH) 1.6 dCi 145 (EGMG) R9M 452; (92-107kW)	07.15-	LUK	SAC  624 3930 33
					 415 0796 10
  ;  MANU  529 0246 10					
 ; für kalte Klimazonen  529 0247 10					
  532 0534 10					
 ;  MANU  534 0624 10					
 # F-236675.XX F-561464.XX  535 0080 10					
 # F-238512.XX  535 0081 10					
 # F-552305.XX  535 0153 10					
 ; A/C ; für kalte Klimazonen  FB 7PK1675					
  FB 7PK1685					
 16x  538 0399 10					
 31 mm  421 0017 10					
FAG	  Set 713 6451 90				
	 818 0207 10				
	 840 0274 10				
	 right  840 0880 10				
	 left  840 0879 10				

TOYOTA

HIACE IV			
2.5 D-4D 4WD (KLH18, KLH28) 2KD-FTV; (65kW)	08.01-08.04		 2KD-FTV  530 0512 10
			 2KD-FTV; OPTION  530 0719 10
			 2KD-FTV  531 0215 20
			 2KD-FTV  533 0108 10
			 2KD-FTV;   534 0360 10
			 # 214V1-1 F-567525.XX  535 0173 10
			 # 361V1-1 F-585322.XX 357V1-1 328V2-2  535 0232 10
			 16x;  2KD-FTV  538 0534 10
			 31 mm  421 0017 10
			FAG
		 ;  BM LXH22	
		 ;  BM RCH12	
		 ;  BM RCH13	
		 ;  BM RCH22	



			<p>SCHAEFFLER</p>
--	--	--	--------------------------

TOYOTA

















































































































































HIACE IV

<p>2.5 D-4D 4WD (KLH18, KLH28) 2KD-FTV; (65kW)</p>	<p>08.01-08.04</p>	<p>FAG</p>	<p> BM LXH18 BM LXH28 BM RCH18 BM RCH19 BM RCH28 BM RCH29 BM KLH18 BM KLH28</p>	<p> Set 713 6188 90</p>
<p>2.5 D-4D (KLH12, KLH22) 2KD-FTV; (65-75kW)</p>	<p>08.01-08.06</p>	<p>LUK</p>	<p>→11.05; DCR HDCR</p>	<p> 624 3390 00 626 3015 60 530 0512 10 530 0719 10 531 0215 20 533 0108 10 534 0360 10 535 0173 10 535 0232 10 FB 7PK1093 538 0534 10 421 0017 10</p>
		<p></p>	<p>OPTION</p> <p> 214V1-1 F-567525.XX 361V1-1 F-585322.XX 357V1-1 328V2-2 ; A/C</p> <p>16x; 2KD-FTV 31 mm</p>	<p> 821 0743 10 821 0742 10 Set 713 6183 00</p>
<p>2.5 D-4D (KLH12, KLH22) 2KD-FTV; (70kW)</p>	<p>09.06-12.12</p>	<p>FAG</p>	<p> right ↑ up left ↑ up</p> <p> BM LXH12 BM LXH22 BM RCH12 BM RCH13 BM RCH22 BM RCH23 BM KLH12 BM KLH22 BM LXH18 BM LXH28 BM RCH18 BM RCH19 BM RCH28 BM RCH29 BM KLH18 BM KLH28</p>	<p> Set 713 6188 90</p> <p> Set 713 6188 80</p> <p> 818 0396 10 818 0413 10 818 0395 10 818 0412 10 825 0011 10 840 0340 10 840 1136 10 626 3015 60 530 0512 10 530 0719 10 531 0215 20 533 0108 10 534 0360 10 535 0173 10 535 0232 10 FB 7PK1933 538 0534 10 821 0743 10 821 0742 10</p>



			SCHAEFFLER
--	--	--	-------------------

TOYOTA



















































































HIACE IV						
2.5 D-4D (KLH12, KLH22) 2KD-FTV; (70kW)	09.06-12.12	FAG	 ;  BM LXH12	 Set	713 6183 00	
			 ;  BM LXH22			
			 ;  BM RCH12			
			 ;  BM RCH13			
			 ;  BM RCH22			
			 ;  BM RCH23			
			 ;  BM KLH12			
			 ;  BM KLH22			
			 ;  BM LXH18	 Set	713 6188 90	
			 ;  BM LXH28			
			 ;  BM RCH18			
			 ;  BM RCH19			
			 ;  BM RCH28			
			 ;  BM RCH29			
			 ;  BM KLH18			
			 ;  BM KLH28			
				 Set	713 6188 80	
			 88 mm			
			 right		818 0396 10	
			 right		818 0413 10	
 left		818 0395 10				
 left		818 0412 10				
		825 0011 10				
 ; RWD		840 0340 10				
 ↔		840 1136 10				
2.5 D-4D 4WD (KLH18, KLH28) 2KD-FTV; (75kW)	08.01-08.06	LUK	→ 11.05;   DCR		624 3390 00	
			  HDCR		626 3015 60	
					530 0512 10	
					530 0719 10	
					531 0215 20	
					533 0108 10	
					534 0360 10	
			 # 214V1-1 F-567525.XX		535 0173 10	
			 # 361V1-1 F-585322.XX 357V1-1 328V2-2		535 0232 10	
			 ; A/C		FB 7PK1093	
			 16x;  2KD-FTV		538 0534 10	
			 31 mm		421 0017 10	
			FAG	 ;  right ↑ up		821 0743 10
				 ;  left ↑ up		821 0742 10
				 ;  BM LXH12	 Set	713 6183 00
				 ;  BM LXH22		
				 ;  BM RCH12		
				 ;  BM RCH13		
				 ;  BM RCH22		
				 ;  BM RCH23		
 ;  BM KLH12						
 ;  BM KLH22						
 ;  BM LXH18	 Set	713 6188 90				
 ;  BM LXH28						
 ;  BM RCH18						
 ;  BM RCH19						
 ;  BM RCH28						
 ;  BM RCH29						
 ;  BM KLH18						
 ;  BM KLH28						
	 Set	713 6188 80				
 88 mm						
 right		818 0396 10				
 right		818 0413 10				
 left		818 0395 10				
 left		818 0412 10				
		825 0011 10				
		840 0340 10				
 ↔		840 1136 10				
2.5 D-4D 4WD (KLH18) 2KD-FTV; (75kW)	11.01-08.06	LUK	→ 11.05;   DCR		624 3390 00	
			  HDCR		626 3015 60	
					530 0512 10	
			OPTION		530 0719 10	



			<p>SCHAEFFLER</p>
--	---	--	--------------------------

TOYOTA















































































































































HIACE IV

<p>2.5 D-4D 4WD (KLH18) 2KD-FTV; (75kW)</p>	<p>11.01-08.06</p>	<p></p>	<p>FAG</p> <ul style="list-style-type: none">  BM LXH12  BM LXH22  BM RCH12  BM RCH13  BM RCH22  BM RCH23  BM KLH12  BM KLH22  BM LXH18  BM LXH28  BM RCH18  BM RCH19  BM RCH28  BM RCH29  BM KLH18  BM KLH28 	<ul style="list-style-type: none">  531 0215 20  533 0108 10  534 0360 10  535 0173 10  538 0534 10  Set 713 6183 00  Set 713 6188 90  Set 713 6188 80  818 0396 10  818 0413 10  818 0395 10  818 0412 10  825 0011 10  840 0340 10  840 1136 10
<p>2.5 D-4D (KLH12, KLH22) 2KD-FTV; (86kW)</p>	<p>08.06-12.12</p>	<p></p> <p></p>	<p>09.06 →</p> <p>OPTION</p> <ul style="list-style-type: none">  530 0512 10  530 0719 10  531 0215 20  533 0108 10  534 0360 10  535 0173 10  535 0232 10  FB 7PK1933  538 0534 10  Set 713 6183 00  Set 713 6188 90  Set 713 6188 80  818 0396 10  818 0413 10  818 0395 10  818 0412 10  840 0340 10  840 1136 10 	<ul style="list-style-type: none">  626 3015 60  530 0512 10  530 0719 10  531 0215 20  533 0108 10  534 0360 10  535 0173 10  535 0232 10  FB 7PK1933  538 0534 10  Set 713 6183 00  Set 713 6188 90  Set 713 6188 80  818 0396 10  818 0413 10  818 0395 10  818 0412 10  840 0340 10  840 1136 10
<p>2.5 D-4D (KLH12, KLH22) 2KD-FTV; (86kW)</p>	<p>09.06-12.12</p>	<p></p> <p></p>	<p> 530 0512 10</p> <p> 530 0719 10</p> <p> 531 0215 20</p> <p> 533 0108 10</p>	<ul style="list-style-type: none">  626 3015 60  530 0512 10  530 0719 10  531 0215 20  533 0108 10



			SCHAEFFLER
--	---	--	-------------------

TOYOTA



TOYOTA				
HIACE IV				
2.5 D-4D (KLH12, KLH22) 2KD-FTV; (86kW)	09.06-12.12			
			 534 0360 10	
			 # 214V1-1 F-567525.XX	 535 0173 10
			 # 361V1-1 F-585322.XX 357V1-1 328V2-2	 535 0232 10
			 ; A/C	 FB 7PK1933
				 538 0534 10
			FAG	 Set 713 6183 00
			 ;  BM LXH12	
			 ;  BM LXH22	
			 ;  BM RCH12	
			 ;  BM RCH13	
			 ;  BM RCH22	
			 ;  BM RCH23	
			 ;  BM KLH12	
			 ;  BM KLH22	
			 ;  BM LXH18	 Set 713 6188 90
			 ;  BM LXH28	
			 ;  BM RCH18	
			 ;  BM RCH19	
			 ;  BM RCH28	
 ;  BM RCH29				
 ;  BM KLH18				
 ;  BM KLH28				
	 Set 713 6188 80			
 88 mm				
 right	 818 0396 10			
 right	 818 0413 10			
 left	 818 0395 10			
 left	 818 0412 10			
 ; RWD	 825 0011 10			
 ;  RWD	 840 0340 10			
 ;  ↔	 840 1136 10			
 ;  BM KLH12; KLH22 KLH18; KLH28	 626 3015 60			
2.5 D-4D 4WD (KLH18) 2KD-FTV; (86kW)	09.06-12.12			
			 530 0512 10	
			OPTION	 530 0719 10
				 531 0215 20
				 533 0108 10
				 534 0360 10
			 # 214V1-1 F-567525.XX	 535 0173 10
			 # 361V1-1 F-585322.XX 357V1-1 328V2-2	 535 0232 10
			 ; A/C	 FB 7PK1933
				 538 0534 10
			FAG	 Set 713 6183 00
			 ;  BM LXH12	
			 ;  BM LXH22	
			 ;  BM RCH12	
			 ;  BM RCH13	
			 ;  BM RCH22	
			 ;  BM RCH23	
			 ;  BM KLH12	
			 ;  BM KLH22	
			 ;  BM LXH18	 Set 713 6188 90
 ;  BM LXH28				
 ;  BM RCH18				
 ;  BM RCH19				
 ;  BM RCH28				
 ;  BM RCH29				
 ;  BM KLH18				
 ;  BM KLH28				
	 Set 713 6188 80			
 88 mm				
 right	 818 0396 10			
 right	 818 0413 10			
 left	 818 0395 10			
 left	 818 0412 10			
 ; RWD	 825 0011 10			
 ;  RWD	 840 0340 10			
 ;  ↔	 840 1136 10			
 ;  BM KLH12; KLH22 KLH18; KLH28	 626 3015 60			
2.5 D-4D 4WD (KLH28, KLH18) 2KD-FTV; (86kW)	09.06-12.12			
			 530 0512 10	
			 530 0719 10	
	 531 0215 20			



			<p>SCHAEFFLER</p>
--	--	--	--------------------------

TOYOTA

HIACE IV

<p>2.5 D-4D 4WD (KLH28, KLH18) 2KD-FTV; (86kW)</p>	<p>09.06-12.12</p>		<p> 214V1-1 F-567525.XX 361V1-1 F-585322.XX 357V1-1 328V2-2 ; A/C </p> <p>FAG</p> <p> BM LXH12 BM LXH22 BM RCH12 BM RCH13 BM RCH22 BM RCH23 BM KLH12 BM KLH22 BM LXH18 BM LXH28 BM RCH18 BM RCH19 BM RCH28 BM RCH29 BM KLH18 BM KLH28 </p> <p> 88 mm right right left left RWD ↔ </p>	<p> 533 0108 10 534 0360 10 535 0173 10 535 0232 10 FB 7PK1933 538 0534 10 Set 713 6183 00 Set 713 6188 90 Set 713 6188 80 818 0396 10 818 0413 10 818 0395 10 818 0412 10 825 0011 10 840 0340 10 840 0340 10 840 1136 10 </p>
<p>2.7 (RCH13, RCH23) 3RZ-FE; (106kW)</p>	<p>07.98-12.06</p>	  <p>FAG</p>	<p> 16x 31 mm right ↑ up left ↑ up BM LXH12 BM LXH22 BM RCH12 BM RCH13 BM RCH22 BM RCH23 BM KLH12 BM KLH22 BM LXH18 BM LXH28 BM RCH18 BM RCH19 BM RCH28 BM RCH29 BM KLH18 BM KLH28 </p> <p> 88 mm right right left left ↔ </p>	<p> 625 3010 00 FB 5PK865 421 0017 10 821 0743 10 821 0742 10 Set 713 6183 00 Set 713 6188 90 Set 713 6188 80 818 0396 10 818 0413 10 818 0395 10 818 0412 10 825 0011 10 840 0340 10 840 1136 10 </p>





























































































HIACE V

<p>2.5 D-4D 2KD-FTV; (70kW)</p>	<p>09.06-</p>		<p> 2KD-FTV 2KD-FTV 2KD-FTV 2KD-FTV 2KD-FTV; </p>	<p> 530 0512 10 530 0719 10 531 0215 20 533 0108 10 534 0360 10 </p>
--	---------------	---	---	--

















































			SCHAEFFLER
--	--	--	-------------------

TOYOTA

HIACE V			
2.5 D-4D 2KD-FTV; (70kW)	09.06-	 FAG	 # 361V1-1 F-585322.XX 357V1-1 328V2-2  535 0232 10  538 0534 10  Set 713 6211 30  840 0340 10
			 530 0512 10  530 0719 10  531 0215 20  533 0108 10  534 0360 10  # 361V1-1 F-585322.XX 357V1-1 328V2-2  535 0232 10  ; A/C  FB 7PK1933  538 0534 10  Set 713 6211 30  840 0340 10
2.5 D-4D (KDH20_, KDH21_, KDH22_, KDH200) 2KD-FTV; (75kW)	06.04-	 FAG	 530 0512 10  530 0719 10  531 0215 20  533 0108 10  534 0360 10  # 361V1-1 F-585322.XX 357V1-1 328V2-2  535 0232 10  ; A/C  FB 7PK1933  538 0534 10  Set 713 6211 30  840 0340 10
			 530 0512 10  530 0719 10  531 0215 20  533 0108 10  534 0360 10  # 361V1-1 F-585322.XX 357V1-1 328V2-2  535 0232 10  ; A/C  FB 7PK1933  538 0534 10  Set 713 6211 30  840 0340 10
2.5 D-4D 2.5 D-4D 4WD (KDH205, KDH227, KDH225) 2KD-FTV; (75-94kW)	08.04-	 FAG	 530 0512 10  530 0719 10  531 0215 20  533 0108 10  534 0360 10  # 361V1-1 F-585322.XX 357V1-1 328V2-2  535 0232 10  ; A/C  FB 7PK1933  538 0534 10  Set 713 6211 30  840 0340 10
			 530 0512 10  530 0719 10  531 0215 20  533 0108 10  534 0360 10  # 361V1-1 F-585322.XX 357V1-1 328V2-2  535 0232 10  ; A/C  FB 7PK1933  538 0534 10  Set 713 6211 30  840 0340 10
2.5 D-4D (KDH200, KDH202, KDH212, KDH222) 2KD-FTV; (86kW)	09.06-	 FAG	 530 0512 10  530 0719 10  531 0215 20  533 0108 10  534 0360 10  # 361V1-1 F-585322.XX 357V1-1 328V2-2  535 0232 10  ; A/C  FB 7PK1933  538 0534 10  Set 713 6211 30  840 0340 10
			 530 0512 10  530 0719 10  531 0215 20  533 0108 10  534 0360 10  # 361V1-1 F-585322.XX 357V1-1 328V2-2  535 0232 10  ; A/C  FB 7PK1933  538 0534 10  Set 713 6211 30  840 0340 10

VAUXHALL











































































































COMBO Mk II (C) (F25)			
1.3 CDTI 16V Z 13 DT; (51kW)	09.04-02.12	 	 →2494873;  MANU incl.  ; incl.   2494874 →;  MANU incl.  ; incl.   →2494873;  MANU  SEMI ;  Easytronic SAC  2494874 →;  MANU  →2494873;  MANU  SEMI ;  Easytronic incl.   2494874 →;  MANU  411 0124 10  529 0346 10  ; A/C  534 0053 10  # F-237101.XX  535 0063 10  # F-557928.XX  535 0151 10  544 0029 10  ; A/C  FB 6PK1180  538 0442 10  400 0577 10  1x  428 0030 30  1x  KIT 559 0019 10  1x  KIT 559 0027 30  1x  KIT 559 0028 30  1x  KIT 559 0053 10 1x KIT 559 0135 10 1x KIT 559 0146 10 FAG right; - bad road pack. 821 0292 10 left; - bad road pack. 821 0291 10 Set 713 6440 80 67 mm ; ABS Set 713 6445 50 136 mm



			SCHAEFFLER
--	---	--	-------------------

VAUXHALL

COMBO Mk II (C) (F25)











































































































































1.3 CDTI 16V Z 13 DT; (51kW)	09.04-02.12	FAG	; ABS  136 mm	 Set 713 6445 60
			;	 REP 815 0028 30
			;	 818 0174 10
			;	825 0128 10
			 ↔;  ...43000001→	 840 0415 10
			 ↔;  ...44000001→	
			 ↔;  ...46000001→	
			 ;  →33999999 34999999 36999999	 840 0156 10
			;	840 0785 10
			 →2494873;  MANU	 600 0164 00
			incl.  ; incl. 	
			 2494874 →  3740424;  MANU	 600 0165 00
			incl.  ; incl. 	
			 →2494873;  MANU	 622 3095 33
 SEMI ;  Easytronic	 622 3100 33			
SAC				
 2494874 →  3740424;  MANU	 622 3146 33			
 3740425 →;  MANU	 622 3236 33			
 →2494873;  MANU	 415 0232 10			
 SEMI ;  Easytronic				
incl. 				
 2494874 →  3740424;  MANU	 415 0442 10			
		 411 0124 10		
1.3 CDTI 16V Z 13 DTJ; (55kW)	10.05-11.11		; A/C	 529 0346 10
			;	 534 0053 10
			 # F-237101.XX	 535 0063 10
			 # F-557928.XX	 535 0151 10
			; A/C	 544 0029 10
				 FB 6PK1180
				 538 0442 10
				 400 0577 10
			1x	 428 0030 30
			1x	 559 0019 10
			1x	 559 0027 30
			1x	 559 0028 30
		1x	 559 0053 10	
		1x	 559 0135 10	
		1x	 559 0146 10	
		FAG	right; - bad road pack.	 821 0292 10
			left; - bad road pack.	 821 0291 10
			;	 Set 713 6440 80
			 67 mm	
			; ABS	 Set 713 6445 50
			 136 mm	
			; ABS	 Set 713 6445 60
			 136 mm	
				 771 0285 30
 81 mm				
	 SET 772 0157 30			
;	 REP 815 0028 30			
;	 818 0174 10			
;	825 0128 10			
 ↔;  ...43000001→	 840 0384 10			
 ↔;  ...44000001→				
 ↔;  ... 46000001→				
 ;  →33999999 34999999 36999999	 840 0156 10			
;	840 0785 10			
	 530 0441 10			
1.4 16V Z 14 XE; (66kW)	10.01-05.07		 02MZ5254 →	 530 0441 30
			 20U75999 →	
			 →02MZ5253	 530 0441 32
			 →20U75998	
			 531 0518 30	
			 532 0033 10	
			 532 0478 10	
		; A/C	 529 0008 10	
		;	 534 0115 20	
		 # 920501	 535 0172 10	



			SCHAEFFLER
--	--	--	-------------------

VAUXHALL

COMBO Mk II (C) (F25)











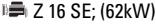



















































































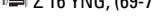











































<p>1.4 16V  Z 14 XE; (66kW)</p>	<p>10.01-05.07</p>	<p>  ; A/C  →02MZ5253, 20U75998  02MZ5254, 20U75999→ 16x  32 mm    FAG  right; - bad road pack.  left; - bad road pack.   67 mm  ; ABS  136 mm  ; ABS  136 mm    ↔;  ...43000001→  ↔;  ...44000001→  ↔;  ...46000001→  ;  →33999999 34999999 36999999 </p>	<p> FB 5PK940  538 0024 10  538 0296 10  420 0118 10  428 0122 10  428 0093 10  821 0292 10  821 0291 10  Set 713 6440 80  Set 713 6445 50  Set 713 6445 60  REP 815 0028 30  818 0174 10  825 0128 10  840 0415 10  840 0156 10  840 0785 10  620 3090 34</p>
<p>1.4 i 16V  Z 14 XEP; (66kW)</p>	<p>01.04-11.11</p>	<p>   ; A/C  ; A/C  ; A/C ;    # F-237101.XX    400 0577 10 16x  13 mm 16x  422 0006 10 1x;  →19TR2328  559 0024 30 1x;  →19TR2328  559 0025 30 1x;  →19TR2328  559 0057 10 FAG  right; - bad road pack.  left; - bad road pack.   67 mm  ; ABS  136 mm  ; ABS  136 mm    81 mm     ↔;  ...43000001→  ↔;  ...44000001→  ↔;  ...46000001→  ;  →33999999 34999999 36999999 </p>	<p> 529 0296 10  529 0324 10  529 0010 30  533 0085 30  535 0063 10  538 0082 10  538 0320 10  420 0072 10  422 0006 10  KIT 559 0024 30  KIT 559 0025 30  KIT 559 0057 10  821 0292 10  821 0291 10  Set 713 6440 80  Set 713 6445 50  Set 713 6445 60  771 0285 30  SET 772 0157 30  REP 815 0028 30  818 0174 10  825 0128 10  840 0415 10  840 0156 10  840 0785 10  621 3027 33</p>
<p>1.6  Z 16 SE; (62kW)</p>	<p>09.01-10.04</p>	<p>   ; A/C    ; A/C   ; A/C  →02MZ5253, 20U75998  02MZ5254, 20U75999→ 1x FAG  right; - bad road pack.  left; - bad road pack.</p>	<p> 530 0004 10  530 0004 31  531 0101 30  529 0008 10  534 0115 20  FB 5PK940  538 0012 10  538 0302 10  428 0041 30  821 0292 10  821 0291 10</p>



			SCHAEFFLER
--	---	--	-------------------

VAUXHALL

COMBO Mk II (C) (F25)



























































































1.6  Z 16 SE; (62kW)	09.01-10.04	FAG	 67 mm		713 6440 80
			 ; ABS		713 6445 50
			 136 mm		713 6445 60
			 ; ABS		713 6445 60
			 136 mm		815 0028 30
					818 0174 10
					825 0128 10
			 ↔;  ...43000001→		840 0415 10
			 ↔;  ...44000001→		
			 ↔;  ...46000001→		
			 ;  →33999999 34999999 36999999		840 0156 10
					840 0785 10
					621 3027 33
			1.6  Z 16 SE; (64kW)	10.01-11.11	LUK
		530 0004 31			
		531 0101 30			
 ; A/C		529 0008 10			
		534 0115 20			
 ; A/C		FB 5PK940			
 →02MZ5253, 20U75998		538 0012 10			
 02MZ5254, 20U75999→		538 0302 10			
1x		428 0041 30			
		821 0292 10			
 right; - bad road pack.		821 0291 10			
 left; - bad road pack.		713 6440 80			
		713 6445 50			
 67 mm		713 6445 60			
 ; ABS		713 6445 60			
 136 mm		713 6445 60			
 ; ABS		713 6445 60			
 136 mm		713 6445 60			
 81 mm		771 0285 30			
		772 0157 30			
		815 0028 30			
		818 0174 10			
		825 0128 10			
 ↔;  ...43000001→		840 0415 10			
 ↔;  ...44000001→					
 ↔;  ...46000001→					
 ;  →33999999 34999999 36999999		840 0156 10			
		840 0785 10			
1.6 CNG 16V  Z 16 YNG; (69-71kW)	04.05-02.12	LUK			530 0441 10
					530 0441 30
					531 0518 30
					532 0033 10
					532 0478 10
			 ; A/C		529 0008 10
					534 0115 20
			 ; A/C		FB 5PK940
					538 0296 10
			16x		420 0118 10
		 32 mm		428 0093 10	
		 ; 1x		713 6440 80	
				713 6445 50	
		 67 mm		713 6445 60	
		 ; ABS		713 6445 60	
		 136 mm		713 6445 60	
		 ; ABS		713 6445 60	
		 136 mm		713 6445 60	
				815 0028 30	
				818 0174 10	
				825 0128 10	
		 ↔;  ...43000001→		840 0415 10	
 ↔;  ...44000001→					
 ↔;  ...46000001→					
 ;  →33999999 34999999 36999999		840 0156 10			
		840 0785 10			



			SCHAEFFLER
--	--	--	-------------------

VAUXHALL

COMBO Mk II (C) (F25)







































<p>1.7 DI 16V  Y 17 DTL; (48kW)</p>	<p>09.01-11.11</p>	<p> </p>			621 3029 34	
			OPTION		530 0492 10	
					530 0494 10	
					531 0819 10	
					532 0504 10	
					529 0345 10	
					534 0082 30	
					FB 6PK1250	
					538 0096 10	
			16x 		421 0059 10	
					428 0098 10	
					428 0097 10	
		<p>FAG</p>	<p></p>			
				right; - bad road pack.		821 0292 10
				left; - bad road pack.		821 0291 10
						713 6440 80
						713 6445 50
						713 6445 60
						815 0028 30
						818 0174 10
						825 0128 10
						840 0415 10
						840 0156 10
						840 0785 10
<p>1.7 DTI 16V  Y 17 DT; (55kW)</p>	<p>10.01-11.11</p>	<p> </p>			621 3029 33	
			OPTION		530 0492 10	
					530 0494 10	
					531 0819 10	
					532 0504 10	
					529 0345 10	
					534 0082 30	
					FB 6PK1250	
					538 0096 10	
			16x 		421 0059 10	
					428 0098 10	
					428 0097 10	
		<p>FAG</p>	<p></p>			
				right; - bad road pack.		821 0292 10
				left; - bad road pack.		821 0291 10
						713 6440 80
						713 6445 50
						713 6445 60
						815 0028 30
						818 0174 10
						825 0128 10
						840 0415 10
						840 0156 10
						840 0785 10
<p>1.7 CDTI 16V  Z 17 DTH; (74kW)</p>	<p>12.04-11.11</p>	<p> </p>	G5		600 0166 00	
			incl.  ; incl. 		623 3234 33	
			G5		415 0256 10	
					411 0121 10	
					530 0492 10	
					530 0494 10	
		OPTION		531 0819 10		
				532 0504 10		
				532 0402 30		
				534 0321 10		



























































			SCHAEFFLER
--	--	--	-------------------

VAUXHALL

COMBO Mk II (C) (F25)

1.7 CDTi 16V Z 17 DTH; (74kW)	12.04-11.11		№# F-232353/.01/.03 F-240113.XX		535 0065 10
					544 0081 10
			 ; A/C		FB 6PK1275
			 ; A/C		FB 6PK1600
					538 0096 10
					421 0059 10
			16x		428 0098 10
			 31 mm		428 0097 10
					821 0292 10
					821 0291 10
		FAG	 right; - bad road pack.		713 6440 80
			 left; - bad road pack.		713 6445 50
			 67 mm		713 6445 60
			 ; ABS		815 0028 30
			 136 mm		818 0174 10
			 ; ABS		825 0128 10
			 136 mm		840 0415 10
			 ;		840 0156 10
			 ;		840 0785 10
			 ↔; ...43000001→		
	 ↔; ...44000001→				
	 ↔; ...46000001→				
	 ; →33999999 34999999 36999999				



COMBO Mk III (D)

1.3 CDTi A 13 FD; (66kW)	11.11-		bis Euro 5		622 3238 00
					512 0437 10
			 ; A/C		529 0380 10
					532 0907 10
					534 0455 10
			№# F-238822.XX		535 0112 10
			№# F-557928.XX		535 0151 10
			№# F-583190		535 0311 10
					544 0029 10
			 ; A/C		FB 6PK1525
				538 0442 10	
				400 0577 10	
				420 0181 10	
		16x		422 0064 10	
		 12 mm		559 0019 10	
		16x		559 0027 30	
		1x		559 0028 30	
		1x		559 0053 10	
		1x		559 0135 10	
		1x		559 0146 10	
		FAG	 right		821 0908 10
			 left		821 0893 10
			 ;		713 6908 00
			 74 mm		713 6908 10
			 ;		713 6909 80
			 82,5 mm		713 6909 90
			 ;		818 0278 10
			 ↔		825 0380 10
			↔		840 0404 10
			↔		
1.3 CDTi (70kW)	03.16-		№# F-557928.XX		535 0151 10
			№# F-583190		535 0311 10
					400 0577 10
		FAG	 right		821 0908 10
			 left		821 0893 10
			 ;		713 6908 00
	 74 mm		713 6908 10		
	 ;		713 6908 10		
	82,5 mm		713 6909 80		
	;				



			SCHAEFFLER
--	--	--	-------------------

VAUXHALL

COMBO Mk III (D)			
1.3 CDTi 70kW	03.16-	FAG	; Set 713 6909 90
			↔ 818 0278 10
			↔ 825 0380 10
			↔ 840 0404 10
1.4 A 14 FP; (70kW)	11.11-		530 0228 10
			; A/C 530 0228 30
			531 0414 30
			; A/C 529 0013 10
			; A/C 534 0069 10
			FB 4PK668
			538 0062 10
			16x 420 0210 10
			right 821 0908 10
			left 821 0893 10
			; 74 mm Set 713 6908 00
			; 82,5 mm Set 713 6908 10
			; Set 713 6909 80
			; Set 713 6909 90
↔ 818 0278 10			
↔ 825 0380 10			
↔ 840 0404 10			
1.6 CDTi A 16 FDH; A 16 FDL; (66-77kW)	11.11-	LUK	SEMI ; Easytronic ; EURO 5 623 3540 00
			EURO 5 ; G6 624 3742 33
			SAC
			EURO 5 ; G6 ; START/STOP 415 0541 10
			EURO 5 ; G6 ; START/STOP 415 0679 10
			EURO 5 ; Easytronic ; START/STOP 415 0720 10
			G6 411 0122 10
			530 0561 10
			; A/C 530 0561 30
			531 0844 10
			; A/C 532 0611 10
			532 0505 10
			532 0617 10
			534 0610 10
# F-238822.XX 535 0112 10			
# F-565229.XX F-568861.XX 535 0181 10			
; A/C 544 0080 20			
; A/C FB 6PK1370			
FB 6PK1705			
538 0714 10			
16x 420 0181 10			
16x 422 0075 10			
right 821 0908 10			
left 821 0893 10			
; 74 mm Set 713 6908 00			
; 82,5 mm Set 713 6908 10			
; Set 713 6909 80			
; Set 713 6909 90			
↔ 818 0278 10			
↔ 825 0380 10			
↔ 840 0404 10			
2.0 CDTi A 20 FD; (99kW)	11.11-		530 0562 10
			; A/C 530 0562 30
			531 0844 10
			; A/C 532 0611 10
			532 0505 10
			532 0617 10
			534 0610 10
			# F-238822.XX 535 0112 10
# F-565229.XX F-568861.XX 535 0181 10			



			SCHAEFFLER
--	--	--	-------------------

VAUXHALL

COMBO Mk III (D)

2.0 CDTi
 A 20 FD; (99kW)

11.11-



			544 0080 20
			FB 6PK1370
			FB 6PK1705
			538 0714 10
			420 0181 10
	16x		
	12 mm		
	16x		
			422 0075 10
FAG			821 0908 10
	right		821 0893 10
	left		821 0893 10
			Set
	74 mm		713 6908 00
			Set
	82,5 mm		713 6908 10
			Set
			713 6909 80
			Set
			713 6909 90
			Set
			818 0278 10
			825 0380 10
			840 0404 10

MOVANO Mk I (A) Chassis/Cab (X70)

2.5 CDTi (UD0, ED)
 G9U 754; (73kW)

11.03-12.06



			530 0198 10
			531 0548 10
			532 0313 20
			529 0432 10
			529 0436 10
			532 0333 10
			532 0364 20
	A/C		544 0098 10
			FB 7PK1103
			FB 7PK1795
			428 0185 10
	1x;		428 0186 10
FAG			821 0558 10
	right ↓ down		821 0557 10
	left ↓ down		821 0557 10
			Set
	B001462 →;		713 6307 90
	B000486 →;		
	B000207 →;		
	B000807 →;		
	B000184 →;		
	16 "		
	84 mm		
			Set
	→B001461;		713 6308 00
	→B000485;		
	→B000206;		
	→B000806;		
	→B000183;		
	16 "		Set
	80 mm		713 6307 80
			Set
	15 "		713 6308 10
	80 mm		

2.5 CDTi (UD0, ED)
 G9U 650; (74kW)

10.06-12.10











































LUK	G5;	PK5.016 PK5.017 PK5.020 PK5.021	GearBOX	462 0202 10
	G6;			
		PK6.019 PK6.020 PK6.029 PK6.030 PK6.069 PK6.070		
		PK6.079 PK6.080		
	G5;	PK5.366 PK5.367 PK5.370	GearBOX	462 0203 10
	G6;	PK6.370		
				624 3476 09
		PK5;		624 3476 34
				530 0198 10
				531 0548 10
				532 0313 20
		→09.10; A/C; OPTION		529 0437 10
		→09.10; ; OPTION		
		A/C		532 0333 10
		→09.10; A/C		532 0364 20



			SCHAEFFLER
--	--	--	-------------------

VAUXHALL

MOVANO Mk I (A) Chassis/Cab (X70)

2.5 CDTi (UD0, ED) G9U 650; (74kW)	10.06-12.10		09.10→; A/C		532 0534 10		
			A/C		534 0181 10		
			; e				
			A/C		534 0317 10		
			; e				
			G9U 754		535 0081 10		
			F-238512.XX				
			A/C		544 0098 10		
			A/C		FB 7PK1113		
			; e				
			A/C		FB 7PK1795		
			; e				
			A/C ; OPTION		FB 7PK1835		
			; e ; OPTION				
			16x		538 0374 10		
			11 mm		420 0063 10		
			1x;		428 0185 10		
			1x;		428 0186 10		
		FAG	right ↓ down; →09.07		821 0558 10		
			right ↓ down; 09.07→		821 0857 10		
			left ↓ down; →09.07		821 0557 10		
			left ↓ down; 09.07→		821 0855 10		
			; B001462→; 15 "	 Set	713 6307 90		
			; B000486→; 15 "				
			; B000207→; 15 "				
			; B000807→; 15 "				
			; B000184→; 15 "				
			; 16 "				
			84 mm				
			→B001461; 15 "			 Set	713 6308 00
			→B000485; 15 "				
			→B000206; 15 "				
			→B000806; 15 "				
			; →B000183; 15 "	 Set	713 6307 80		
			84 mm				
			; 16 "	 Set	713 6308 10		
			80 mm				
			; 15 "	 Set	713 6308 10		
		80 mm					
		right		818 0206 10			
		left		818 0205 10			
		↓ down; →09.07		825 0166 10			
		↑ up		825 0167 10			
		↑ up		825 0280 10			
		↓ down; 09.07→		825 0300 10			
		right		840 0198 10			
		right		840 0878 10			
		left		840 0877 10			
2.5 DTi (ED, UD0) G9U 720; G9U 724; G9U 750; G9U 754; (84kW)	01.01-12.06		G5 ;	 GearBOX	462 0202 10		
			PK5.007 PK5.008 PK5.014 PK5.015 PK5.016 PK5.017 PK5.020 PK5.021				
			G6 ;				
			PK6.019 PK6.020 PK6.029 PK6.030 PK6.069 PK6.070 PK6.079 PK6.080	 GearBOX	462 0203 10		
			G6 ; PK6.370				
			→04.05; PF1 ; № 0##		624 3476 09		
			PK5 ; № 0##				
			PK6 ; № 0##				
			08.04→12.05; SEMI ; Easytronic PA6 ; № 0##				
			05.05→; PK6 ; № 3##		624 3476 34		
							530 0198 10
							531 0548 10
				532 0313 20			
			G9U-750 G9U-754; A/C		529 0432 10		
			G9U-750 G9U-754; e				
			A/C		529 0436 10		
			; e				



			<p>SCHAEFFLER</p>	
--	---	--	-------------------	--

VAUXHALL

MOVANO Mk I (A) Chassis/Cab (X70)

2.5 DTI (ED, UDO)
 G9U 720; G9U 724; G9U 750; G9U 754; (84kW)

01.01-12.06



16x		532 0333 10
11 mm		532 0364 20
1x; ↓		534 0317 10
1x; ↓		535 0081 10
		544 0094 10
		544 0098 10
		FB 6PK1148
		FB 6PK1795
		FB 7PK1103
		FB 7PK1795
		538 0374 10
		420 0063 10
		428 0185 10
		428 0186 10

FAG

right ↓ down		821 0558 10
left ↓ down		821 0557 10
B001462 →; 15"	Set	713 6307 90
B000486 →; 15"		
B000207 →; 15"		
B000807 →; 15"		
B000184 →; 15"		
16"		
84 mm		
→ B001461; 15"	Set	713 6308 00
→ B000485; 15"		
→ B000206; 15"		
→ B000806; 15"		
→ B000183; 15"		
84 mm		
16"	Set	713 6307 80
80 mm		
15"	Set	713 6308 10
80 mm		
ABS		771 0292 30
101,9 mm		
right		818 0206 10
left		818 0205 10
↓ down		825 0166 10
↑ up →		825 0167 10
↑ up ↗		825 0280 10
		840 0198 10
right		840 0878 10
left		840 0877 10

2.5 CDTI (ED, UDO)
 G9U 632; G9U 650; (88-107kW)

08.06-05.10



MANU ; PF6 ; № 0##		624 3476 09
		624 3476 34
		530 0198 10
		531 0548 10
		532 0313 20
		529 0437 10
		532 0333 10
		532 0364 20
		534 0181 10
		534 0317 10
		535 0081 10
		544 0098 10
		FB 7PK1113



			SCHAEFFLER
--	--	--	------------

VAUXHALL

MOVANO Mk I (A) Chassis/Cab (X70)







<p>2.5 CDTi (ED, UD0) G9U 632; G9U 650; (88-107kW)</p>	<p>08.06-05.10</p>	<p></p>	<p> ; A/C ; G9U 754 16x 11 mm 1x; 1x; FAG right ↓ down; →09.07 right ↓ down; 09.07 → left ↓ down; →09.07 left ↓ down; 09.07 → ; B001462 →; 15 " ; B000486 →; 15 " ; B000207 →; 15 " ; B000807 →; 15 " ; B000184 →; 15 " ; 16 " 84 mm ; →B001461; 15 " ; →B000485; 15 " ; →B000206; 15 " ; →B000806; 15 " ; →B000183; 15 " 84 mm ; 16 " 80 mm ; 15 " 80 mm right left ↓ down; →09.07 ↑ up ↑ up ↓ down; 09.07 → right left</p>	<p> FB 7PK1795 538 0374 10 420 0063 10 428 0185 10 428 0186 10 821 0558 10 821 0857 10 821 0557 10 821 0855 10 Set 713 6307 90 Set 713 6308 00 Set 713 6307 80 Set 713 6308 10 818 0206 10 818 0205 10 825 0166 10 825 0167 10 825 0280 10 825 0300 10 840 0198 10 840 0878 10 840 0877 10 624 3476 09 624 3476 34 F-228751.XX FB 7PK1920 538 0384 10 821 0558 10 821 0857 10 821 0557 10 821 0855 10 Set 713 6307 90 Set 713 6308 00 Set 713 6307 80 Set 713 6308 10 818 0206 10 818 0205 10 825 0166 10 825 0167 10 825 0280 10 825 0300 10</p>
<p>3.0 DTi (ED) ZD3 200; ZD3 202; (100kW)</p>	<p>10.03-05.10</p>	<p></p> <p></p> <p>FAG</p>	<p> PF6 ; № 0## F-228751.XX right ↓ down; →09.07 right ↓ down; 09.07 → left ↓ down; →09.07 left ↓ down; 09.07 → ; B001462 →; 15 " ; B000486 →; 15 " ; B000207 →; 15 " ; B000807 →; 15 " ; B000184 →; 15 " ; 16 " 84 mm ; →B001461; 15 " ; →B000485; 15 " ; →B000206; 15 " ; →B000806; 15 " ; →B000183; 15 " 84 mm ; 16 " 80 mm ; 15 " 80 mm right left ↓ down; →09.07 ↑ up ↑ up ↓ down; 09.07 →</p>	<p> 538 0384 10 821 0558 10 821 0857 10 821 0557 10 821 0855 10 Set 713 6307 90 Set 713 6308 00 Set 713 6307 80 Set 713 6308 10 818 0206 10 818 0205 10 825 0166 10 825 0167 10 825 0280 10 825 0300 10</p>



























































































			SCHAEFFLER
--	---	--	-------------------











VAUXHALL

MOVANO Mk I (A) Chassis/Cab (X70)

3.0 DTi (ED) ZD3 200; ZD3 202; (100kW)	10.03-05.10	FAG			840 0198 10
					840 0878 10
					840 0877 10

MOVANO Mk I (A) Combi (X70)

1.9 DTi (JD) F9Q 774; (60kW)	10.01-05.10	LUK	G5 ;  PK5.018 PK5.072	GearBOX	462 0155 10	
			G5 ;  PK5.016	GearBOX	462 0202 10	
			G5 ;  PK5.372	GearBOX	462 0203 10	
			 → C039090		624 3087 09	
			 → C039090; →05.05;  PK5 ;  № 0##		624 3087 33	
			 → C039090; 06.05 →;  PK5.3##		624 3087 34	
			 C039091 →		624 3312 09	
			 C039091 →; →05.05;  PK5 ;  № 0##		624 3312 33	
			 C039091 →; 06.05 →;  PK5 ;  № 3##		624 3312 34	
					530 0196 10	
					530 0196 30	
					533 0087 20	
					529 0118 10	
					529 0124 10	
					529 0427 10	
				532 0243 10		
				532 0364 20		
				534 0142 30		
				535 0030 10		
				535 0048 10		
				544 0089 10		
				544 0101 10		
				544 0101 20		
				FB 6PK1795		
			538 0392 10			
		FAG		right ↓ down; 09.07 →		821 0857 10
				left ↓ down; 09.07 →		821 0855 10
				B001462 →;  15 "		713 6307 90
				B000486 →;  15 "		
				B000207 →;  15 "		
				B000807 →;  15 "		
				B000184 →;  15 "		
				 16 "		713 6308 00
				84 mm		
				→ B001461;  15 "		
				→ B000485;  15 "		
				→ B000206;  15 "		
				→ B000806;  15 "		713 6308 10
				→ B000183;  15 "		
				 16 "		
				80 mm		
				 15 "		
				80 mm		818 0206 10
				right		
				left		
	↓ down; →09.07					
	↑ up 					
	↑ up 			825 0167 10		
	↓ down; 09.07 →					
						
	right					
	left					























































































































2.5 CDTi (JD) G9U 650; (74kW)	10.01-08.09	LUK	G5 ;  PK5.016 PK5.017 PK5.020 PK5.021	GearBOX	462 0202 10
			G6 ;  PK6.019 PK6.020 PK6.029 PK6.030 PK6.070 PK6.079 PK6.080		
			G5 ;  PK5.366 PK5.367 PK5.370	GearBOX	462 0203 10
			G6 ;  PK6.370		
			→12.05;  PK5 ;  № 0##		624 3476 09
01.06 →;  PK5 ;  № 3##		624 3476 33			
				624 3476 34	



			SCHAEFFLER
--	--	--	-------------------

VAUXHALL

MOVANO Mk I (A) Combi (X70)

2.5 CDTi (JD) G9U 650; (74kW)	10.01-08.09				530 0198 10
					531 0548 10
					532 0313 20
					529 0437 10
			 ; A/C ; OPTION		
			 ; -e ; OPTION		
			 ; A/C		532 0333 10
					532 0364 20
			 ; A/C		534 0181 10
			 ; -e		
			 ; A/C		534 0317 10
			 ; -e		
			 G9U 754		535 0081 10
			 # F-238512.XX		
			A/C		544 0098 10
			 ; A/C		FB 7PK1113
			 ; -e		
			 ; A/C		FB 7PK1795
			 ; -e		
					538 0374 10
			16x		420 0063 10
			 11 mm		
			1x; 		428 0185 10
			1x; 		428 0186 10
		FAG	 right ↓ down; 09.07 →		821 0857 10
			 left ↓ down; 09.07 →		821 0855 10
			 ; B001462 →;  15 "	 Set	713 6307 90
			 ; B000486 →;  15 "		
			 ; B000207 →;  15 "		
			 ; B000807 →;  15 "		
			 ; B000184 →;  15 "		
			 ;  16 "		
			 84 mm		
			 ; →B001461;  15 "	 Set	713 6308 00
			 ; →B000485;  15 "		
			 ; →B000206;  15 "		
			 ; →B000806;  15 "		
			 ; →B000183;  15 "		
			 84 mm		
			 ;  16 "	 Set	713 6307 80
			 80 mm		
			 ;  15 "	 Set	713 6308 10
			 80 mm		
			 right		818 0206 10
			 left		818 0205 10
			 ↓ down; →09.07		825 0166 10
			 ↑ up 		825 0167 10
			 ↑ up 		825 0280 10
			 ↓ down; 09.07 →		825 0300 10
					840 0198 10
			 right		840 0878 10
			 left		840 0877 10
2.5 DTi (JD) G9U 720; G9U 724; G9U 750; G9U 754; (84kW)	10.01-08.09		G5 ;	GearBOX	462 0202 10
			 PK5.007 PK5.008 PK5.014 PK5.015 PK5.016 PK5.017 PK5.020 PK5.021		
			G6 ;		
			 PK6.019 PK6.020 PK6.029 PK6.030 PK6.069 PK6.070 PK6.079 PK6.080		
			G5 ;  PK5.366 PK5.367 PK5.370		
			G6 ;  PK6.370		
				624 3476 09	
		→04.05;  PF1 ;  № 0##		624 3476 33	
		 PK5 ;  № 0##			
		 PK6 ;  № 0##			
		08.04 → 12.05;  SEMI ;  Easytronic PA6 ;  № 0##			
		05.05 →;  PK6 ;  № 3##		624 3476 34	
		530 0198 10			
		531 0548 10			
		532 0313 20			
		529 0432 10			
		 ;  G9U-750 G9U-754; A/C			
		 ;  G9U-750 G9U-754; -e			



			SCHAEFFLER
--	--	--	-------------------

VAUXHALL















































MOVANO Mk I (A) Combi (X70)

2.5 DTI (JD)

▣ G9U 720; G9U 724; G9U 750; G9U 754; (84kW)

10.01-08.09















▣ ; A/C		529 0436 10
▣ ; 6		
▣ ; A/C		532 0333 10
▣		532 0364 20
▣ ; A/C		534 0317 10
▣ ; 6		
▣# F-238512.XX		535 0081 10
▣ G9U720; A/C		544 0094 10
▣ G9U724; A/C		
▣ G9U750; A/C		544 0098 10
▣ G9U754; A/C		
▣ ; ▣ G9T-720 G9T-722; A/C		FB 6PK1148
▣ ; ▣ G9T-720 G9T-722; 6		
▣ ; ▣ G9T-720 G9T-722; A/C		FB 6PK1795
▣ ; ▣ G9T-720 G9T-722; 6		
▣ ; ▣ G9U-750 G9U-754; A/C ; OPTION		FB 7PK1103
▣ ; ▣ G9U-750 G9U-754; 6 ; OPTION		
▣ ; ▣ G9T-750 G9T-754; A/C		FB 7PK1795
▣ ; ▣ G9T-750 G9T-754; 6		
16x		538 0374 10
11 mm		
1x; 		428 0185 10
1x; 		428 0186 10
FAG		
▣ right ↓ down; 09.07 →		821 0857 10
▣ left ↓ down; 09.07 →		821 0855 10
▣ ; B001462 →; 		713 6307 90
▣ ; B000486 →; 		
▣ ; B000207 →; 		
▣ ; B000807 →; 		
▣ ; B000184 →; 		
▣ ; 		
84 mm		
▣ ; →B001461; 		713 6308 00
▣ ; →B000485; 		
▣ ; →B000206; 		
▣ ; →B000806; 		
▣ ; →B000183; 		
84 mm		
▣ ; 		713 6307 80
80 mm		
▣ ; 		713 6308 10
80 mm		
▣ ; ABS		771 0292 30
101,9 mm		
▣ right		818 0206 10
▣ left		818 0205 10
▣ ↓ down; →09.07		825 0166 10
▣ ↑ up 		825 0167 10
▣ ↑ up 		825 0280 10
▣ ↓ down; 09.07 →		825 0300 10
▣		840 0198 10
▣ right		840 0878 10
▣ left		840 0877 10

2.5 CDTI (JD)

▣ G9U 632; G9U 650; (88kW)

02.03-08.09

































































































































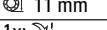



▣ MANU ; ▣ PF6 ; ▣ № 0##		624 3476 09
		624 3476 34
		530 0198 10
		531 0548 10
		532 0313 20
▣ ; A/C ; OPTION		529 0437 10
▣ ; 6 ; OPTION		
▣ ; A/C		532 0333 10
▣		532 0364 20
▣ ; A/C		534 0181 10
▣ ; 6		
▣ ; A/C		534 0317 10
▣ ; 6		
▣# F-238512.XX		535 0081 10
A/C		544 0098 10



			SCHAEFFLER
--	--	--	-------------------

VAUXHALL

MOVANO Mk I (A) Combi (X70)

































2.5 CDTI (JD) G9U 632; G9U 650; (88kW)	02.03-08.09		 ; A/C		FB 7PK1113			
			 ; -e		FB 7PK1795			
2.5 CDTI (JD) G9U 632; (107kW)	08.06-05.10		 ; A/C		FB 7PK1795			
			 ; -e		FB 7PK1795			
			 G9U 754		538 0374 10			
			16x		420 0063 10			
			 11 mm		420 0063 10			
			1x; 		428 0185 10			
			1x; 		428 0186 10			
			FAG	right ↓ down; 09.07 →				821 0857 10
						 left ↓ down; 09.07 →		821 0855 10
						 ; B001462 →;  15 "	 Set	713 6307 90
						 ; B000486 →;  15 "		
						 ; B000207 →;  15 "		
						 ; B000807 →;  15 "		
						 ; B000184 →;  15 "		
						 ;  16 "		
						  84 mm		
						 ; →B001461;  15 "		 Set
			 ; →B000485;  15 "					
			 ; →B000206;  15 "					
			 ; →B000806;  15 "					
			 ; →B000183;  15 "					
			  84 mm					
			 ;  16 "	 Set	713 6307 80			
			  80 mm					
			 ;  15 "		 Set	713 6308 10		
			  80 mm					
			right				818 0206 10	
			left				818 0205 10	
 ↓ down; →09.07		825 0166 10						
 ↑ up 		825 0167 10						
 ↑ up 		825 0280 10						
 ↓ down; 09.07 →		825 0300 10						
		840 0198 10						
right		840 0878 10						
left		840 0877 10						
2.5 CDTI (JD) G9U 632; (107kW)	08.06-05.10		 MANU ;  PF6 ;  Nº 0##		624 3476 09			
					624 3476 34			
					530 0198 10			
					531 0548 10			
					532 0313 20			
			 ; A/C ; OPTION		529 0437 10			
			 ; -e ; OPTION		532 0333 10			
			 ; A/C		532 0364 20			
			 ; A/C		534 0181 10			
			 ; -e		534 0317 10			
			 ; A/C		534 0317 10			
			 ; -e		534 0317 10			
			 # F-238512.XX		535 0081 10			
			A/C		544 0098 10			
			 ; A/C		FB 7PK1113			
			 ; -e		FB 7PK1795			
			 ; A/C		FB 7PK1795			
			 ; -e		FB 7PK1795			
			 G9U 754		538 0374 10			
			16x		420 0063 10			
			 11 mm		420 0063 10			
			1x; 		428 0185 10			
			1x; 		428 0186 10			
			FAG	right ↓ down; 09.07 →				821 0857 10
						 left ↓ down; 09.07 →		821 0855 10









































			SCHAEFFLER
--	---	--	-------------------





VAUXHALL

MOVANO Mk I (A) Combi (X70)

2.5 CDTi (JD) G9U 632; (107kW)	08.06-05.10	FAG	↳; B001462→;  15"		713 6307 90
			↳; B000486→;  15"		
			↳; B000207→;  15"		
			↳; B000807→;  15"		
			↳; B000184→;  15"		
			↳;  16"		
			 84 mm		
			↳; →B001461;  15"		713 6308 00
			↳; →B000485;  15"		
			↳; →B000206;  15"		
			↳; →B000806;  15"		
			↳; →B000183;  15"		
			 84 mm		
			↳;  16"		713 6307 80
			 80 mm		
			↳;  15"		713 6308 10
			 80 mm		
			↳ right		818 0206 10
			↳ left		818 0205 10
			↳ ↓ down; →09.07		825 0166 10
↳ ↑ up 		825 0167 10			
↳ ↑ up 		825 0280 10			
↳ ↓ down; 09.07→		825 0300 10			
↳		840 0198 10			
↳ right		840 0878 10			
↳ left		840 0877 10			

3.0 DTi (JD) ZD3 200; (100kW)	10.03-05.10	LUK	↳ PF6; ↳№ 0##		624 3476 09
			↳ PF6; ↳№ 0##		624 3476 34
			↳ # F-228751.XX		535 0053 10
			↳		FB 7PK1920
			↳		538 0384 10
			↳ right ↓ down; 09.07→		821 0857 10
			↳ left ↓ down; 09.07→		821 0855 10
			↳; B001462→;  15"		713 6307 90
			↳; B000486→;  15"		
			↳; B000207→;  15"		
			↳; B000807→;  15"		
			↳; B000184→;  15"		
			↳;  16"		
			 84 mm		
			↳; →B001461;  15"		713 6308 00
			↳; →B000485;  15"		
			↳; →B000206;  15"		
			↳; →B000806;  15"		
			↳; →B000183;  15"		
			 84 mm		
↳;  16"		713 6307 80			
 80 mm					
↳;  15"		713 6308 10			
 80 mm					
↳ right		818 0206 10			
↳ left		818 0205 10			
↳ ↓ down; →09.07		825 0166 10			
↳ ↑ up 		825 0167 10			
↳ ↑ up 		825 0280 10			
↳ ↓ down; 09.07→		825 0300 10			
↳		840 0198 10			
↳ right		840 0878 10			
↳ left		840 0877 10			

MOVANO Mk I (A) Van (X70)

1.9 DTi (FD) F9Q 774; (60kW)	10.01-05.10	LUK	G5; ↳ PK5.018 PK5.068 PK5.072	GearBOX	462 0155 10
			G5; ↳ PK5.022	GearBOX	462 0202 10
			G5; ↳ PK5.372	GearBOX	462 0203 10
			↳ C039090		624 3087 09
			↳ →C039090; →05.05; ↳ PK5; ↳№ 0##		624 3087 33
			↳ →C039090; 06.05→; ↳ PK5.3##		624 3087 34
			↳ C039091→		624 3312 09
			↳ C039091→; →05.05; ↳ PK5; ↳№ 0##		624 3312 33





VAUXHALL

MOVANO Mk I (A) Van (X70)





















































1.9 DTI (FD) F9Q 774; (60kW)	10.01-05.10	 	C039091 →; 06.05 →; PK5; N° 3##	624 3312 34
			530 0196 10 530 0196 30 533 0087 20 529 0118 10 529 0124 10 529 0427 10 532 0243 10 532 0364 20 534 0142 30 535 0030 10 535 0048 10 544 0089 10 544 0101 10 544 0101 20 FB 6PK1795 538 0392 10	
2.5 CDTI (FD) G9U 650; (74kW)	10.06-12.10	 	right ↓ down; 09.07 → left ↓ down; 09.07 → B001462 →; 15 " B000486 →; 15 " B000207 →; 15 " B000807 →; 15 " B000184 →; 15 " 16 " 84 mm →B001461; 15 " →B000485; 15 " →B000206; 15 " →B000806; 15 " →B000183; 15 " 84 mm 16 " 80 mm 15 " 80 mm right left ↓ down; →09.07 ↑ up ↑ up ↓ down; 09.07 → right left	821 0857 10 821 0855 10 Set 713 6307 90 Set 713 6308 00 Set 713 6307 80 Set 713 6308 10 818 0206 10 818 0205 10 825 0166 10 825 0167 10 825 0280 10 825 0300 10 840 0198 10 840 0878 10 840 0877 10
			G5; PK5.016 PK5.017 PK5.020 PK5.021 G6; PK6.019 PK6.020 PK6.029 PK6.069 PK6.070 PK6.079 PK6.080 G5; PK5.366 PK5.367 PK5.370 G6; PK6.370 624 3476 09 624 3476 34 530 0198 10 531 0548 10 532 0313 20 529 0437 10 532 0333 10 532 0364 20 532 0534 10 534 0181 10 534 0317 10 535 0081 10 544 0098 10	



			SCHAEFFLER
--	---	--	-------------------

VAUXHALL

MOVANO Mk I (A) Van (X70)

2.5 CDTI (FD) G9U 650; (74kW)	10.06-12.10		A/C -e A/C -e A/C ; OPTION -e ; OPTION	    	FB 7PK1113 FB 7PK1795 FB 7PK1835 538 0374 10 420 0063 10
			16x 11 mm 1x 1x	 	428 0185 10 428 0186 10
2.5 DTI (FD) G9U 720; G9U 724; G9U 750; G9U 754; (84kW)	10.01-05.10		right ↓ down; 09.07 → left ↓ down; 09.07 → B001462 →; 15" B000486 →; 15" B000207 →; 15" B000807 →; 15" B000184 →; 15" 16" 84 mm →B001461; 15" →B000485; 15" →B000206; 15" →B000806; 15" →B000183; 15" 84 mm 16" 80 mm 15" 80 mm right left ↓ down; →09.07 ↑ up ↑ up ↓ down; 09.07 → right left	                         	821 0857 10 821 0855 10 713 6307 90 713 6308 00 713 6307 80 713 6308 10 818 0206 10 818 0205 10 825 0166 10 825 0167 10 825 0280 10 825 0300 10 840 0198 10 840 0878 10 840 0877 10
			G5 ; PK5.007 PK5.008 PK5.014 PK5.015 PK5.016 PK5.017 PK5.020 PK5.021 PK5.064 G6 ; PK6.019 PK6.020 PK6.029 PK6.030 PK6.069 PK6.070 PK6.079 PK6.080 G5 ; PK5.366 PK5.367 PK5.370 G6 ; PK6.370 →04.05; PF1 ; N° 0## PK5 ; N° 0## PK6 ; N° 0## 08.04 → 12.05; SEMI ; Easytronic PA6 ; N° 0## 05.05 →; PK6 ; N° 3##	                 	462 0202 10 GearBOX 462 0203 10 624 3476 09 624 3476 33 624 3476 34 530 0198 10 531 0548 10 532 0313 20 529 0432 10 529 0436 10 532 0333 10 532 0364 20 534 0317 10 535 0081 10 544 0094 10



	2001... 2002... 2003...		SCHAEFFLER
--	-------------------------------	--	------------

VAUXHALL

MOVANO Mk I (A) Van (X70)

<p>2.5 DTI (FD) G9U 720; G9U 724; G9U 750; G9U 754; (84kW)</p>	<p>10.01-05.10</p>	<p></p>	<p>G9U750; A/C G9U754; A/C G9T-720 G9T-722; A/C G9T-720 G9T-722; -e G9T-720 G9T-722; A/C G9T-720 G9T-722; e G9U-750 G9U-754; A/C ; OPTION G9U-750 G9U-754; -e ; OPTION G9T-750 G9T-754; A/C G9T-750 G9T-754; e 16x 11 mm 1x; 1x; FAG right ↓ down; 09.07 → left ↓ down; 09.07 → B001462 →; 15 " B000486 →; 15 " B000207 →; 15 " B000807 →; 15 " B000184 →; 15 " 16 " 84 mm →B001461; 15 " →B000485; 15 " →B000206; 15 " →B000806; 15 " →B000183; 15 " 84 mm 16 " 80 mm 15 " 80 mm 101,9 mm right left ↓ down; →09.07 ↑ up ↑ up ↓ down; 09.07 → right left</p>	<p> 544 0098 10 FB 6PK1148 FB 6PK1795 FB 7PK1103 FB 7PK1795 538 0374 10 420 0063 10 428 0185 10 428 0186 10 821 0857 10 821 0855 10 713 6307 90 713 6308 00 713 6307 80 713 6308 10 771 0292 30 818 0206 10 818 0205 10 825 0166 10 825 0167 10 825 0280 10 825 0300 10 840 0198 10 840 0878 10 840 0877 10 624 3476 09 624 3476 34 530 0198 10 531 0548 10 532 0313 20 529 0437 10 532 0333 10 532 0364 20 534 0181 10 534 0317 10 535 0081 10 544 0098 10 FB 7PK1113 FB 7PK1795 538 0374 10 420 0063 10 428 0185 10 428 0186 10</p>
<p>2.5 CDTI (FD) G9U 632; G9U 650; (88-107kW)</p>	<p>08.06-05.10</p>	<p></p> <p></p>	<p>MANU ; PF6 ; N° 0## A/C ; OPTION e ; OPTION A/C A/C A/C e A/C e F-238512.XX A/C A/C e A/C e 16x 11 mm 1x; 1x; </p>	<p> 624 3476 09 624 3476 34 530 0198 10 531 0548 10 532 0313 20 529 0437 10 532 0333 10 532 0364 20 534 0181 10 534 0317 10 535 0081 10 544 0098 10 FB 7PK1113 FB 7PK1795 538 0374 10 420 0063 10 428 0185 10 428 0186 10</p>



			SCHAEFFLER
--	---	--	-------------------































































VAUXHALL

MOVANO Mk I (A) Van (X70)

2.5 CDTi (FD)
 G9U 632; G9U 650; (88-107kW)

08.06-05.10

FAG

 right ↓ down; 09.07 →		821 0857 10
 left ↓ down; 09.07 →		821 0855 10
 ; B001462 →;  15"		713 6307 90
 ; B000486 →;  15"		
 ; B000207 →;  15"		
 ; B000807 →;  15"		
 ; B000184 →;  15"		
 ;  16"		
  84 mm		
 ; → B001461;  15"		713 6308 00
 ; → B000485;  15"		
 ; → B000206;  15"		
 ; → B000806;  15"		
 ; → B000183;  15"		
  84 mm		
 ;  16"		713 6307 80
  80 mm		
 ;  15"		713 6308 10
  80 mm		
 right		818 0206 10
 left		818 0205 10
 ↓ down; → 09.07		825 0166 10
 ↑ up 		825 0167 10
 ↑ up 		825 0280 10
 ↓ down; 09.07 →		825 0300 10
		840 0198 10
 right		840 0878 10
 left		840 0877 10









































































3.0 DTi (FD)
 ZD3 202; (100kW)

10.03-05.10

LUK

INA

FAG















 PF6;  № 0##		624 3476 09
 # F-228751.XX		624 3476 34
		535 0053 10
		FB 7PK1920
		538 0384 10
 right ↓ down; 09.07 →		821 0857 10
 left ↓ down; 09.07 →		821 0855 10
 ; B001462 →;  15"		713 6307 90
 ; B000486 →;  15"		
 ; B000207 →;  15"		
 ; B000807 →;  15"		
 ; B000184 →;  15"		
 ;  16"		
  84 mm		
 ; → B001461;  15"		713 6308 00
 ; → B000485;  15"		
 ; → B000206;  15"		
 ; → B000806;  15"		
 ; → B000183;  15"		
  84 mm		
 ;  16"		713 6307 80
  80 mm		
 ;  15"		713 6308 10
  80 mm		
 right		818 0206 10
 left		818 0205 10
 ↓ down; → 09.07		825 0166 10
 ↑ up 		825 0167 10
 ↑ up 		825 0280 10
 ↓ down; 09.07 →		825 0300 10
		840 0198 10
 right		840 0878 10
 left		840 0877 10

MOVANO Mk II (B)

2.3 CDTi FWD (FV, JV, UV, HV)
 M9T 670; M9T 672; M9T 676;
 M9T 678; M9T 680; M9T 870; M9T
 876; (74-107kW)

05.10-

LUK

 MANU;  PF6;  № 0## incl.  ; incl.  ; SAC		600 0235 00
 MANU;  PF6		626 3049 09
 SEMI;  PA0 Easytronic SAC		
 MANU;  PF6;  № 0## SAC		626 3049 33





VAUXHALL

MOVANO Mk II (B)

2.3 CDTI FWD (FV, JV, UV, HV)
 M9T 670; M9T 672; M9T 676;
 M9T 678; M9T 680; M9T 870; M9T
 876; (74-107kW)

05.10-

	incl.		415 0485 10
	; A/C		529 0317 10
	; A/C		529 0353 10
	; A/C		532 0534 10
			534 0281 10
			535 0080 10
			535 0153 10
			538 0397 10
			420 0086 10
	16x 12 mm		422 0078 10
	16x		558 0060 10
	1x		559 0172 10
	1x		559 0172 30
FAG	right		821 0865 10
	left		821 0868 10
			713 6450 40
	90 mm		713 6450 50
	80 mm		818 0482 10
	↔		818 0475 10
	right; 07.10→		825 0333 10
	left		825 0332 10
	right; →07.10		840 0394 10
	↔		840 1143 10
	right		840 1142 10
	left		626 3050 00

2.3 CDTI RWD (FV)
 M9T 690; M9T 692; M9T 870;
 (74kW)

05.10-

	ZF4		415 0490 10
	incl.		529 0317 10
	; M9T 870; A/C		529 0352 10
	; M9T 870; A/C		529 0353 10
	; M9T 690 M9T 692; A/C		532 0534 10
	; M9T 690 M9T 692; A/C		534 0281 10
	; A/C		535 0080 10
			535 0153 10
			538 0397 10
			420 0086 10
	16x 12 mm		422 0078 10
	16x		558 0060 10
	1x		559 0172 10
	1x		559 0172 30
FAG	right		821 0865 10
	left		821 0868 10
			713 6450 40
	90 mm		713 6450 30
	; RWD ;		713 6451 60
	; RWD ;		818 0482 10
	; 4WD		818 0475 10
	90 mm		818 0492 10
	↔		825 0333 10
	↔ ;		825 0332 10
	↔ ;		840 0394 10
	right; 07.10→		840 1143 10
	left		840 1142 10
	right; →07.10		626 3050 00
	↔		415 0490 10
	right		529 0317 10
	left		

2.3 CDTI RWD (UV, HV)
 M9T 670; M9T 690; M9T 692;
 M9T 870; M9T 890; (74kW)

07.10-

































































































































	ZF4		626 3050 00
	incl.		415 0490 10
	; M9T 670 M9T 870; A/C		529 0317 10
	; M9T 670 M9T 870; A/C		



			<p>SCHAEFFLER</p>
--	--	--	--------------------------

VAUXHALL





































































































MOVANO Mk II (B)

<p>2.3 CDTI RWD (UV, HV) M9T 670; M9T 690; M9T 692; M9T 870; M9T 890; (74kW)</p>	<p>07.10-</p>	<p></p>	<p>;  M9T 690 M9T 692; A/C ;  M9T 690 M9T 692; A/C  ; A/C    # F-236675.XX F-561464.XX # F-552305.XX 16x  12 mm 16x 1x 1x 1x FAG  right  left   90 mm ; RWD;  ; RWD;  ; 4WD  90 mm  ↔  ↔;   ↔;   right  left  ↔  right  left</p>	<p> 529 0352 10  529 0353 10  532 0534 10  534 0281 10  535 0080 10  535 0153 10  538 0397 10  420 0086 10  422 0078 10   558 0060 10   559 0172 10   559 0172 30  821 0865 10  821 0868 10   713 6450 40   713 6450 30   713 6451 60  818 0482 10  818 0475 10  818 0492 10  825 0333 10  825 0332 10  840 0394 10  840 1143 10  840 1142 10</p>
<p>2.3 CDTI FWD (FV) M9T 870; (81kW)</p>	<p>02.12-</p>	<p></p>	<p>; A/C ; A/C  ; A/C   # F-236675.XX F-561464.XX # F-552305.XX 16x  12 mm 16x FAG  right  left   90 mm  80 mm  ↔  ↔  right  left  ↔  right  left</p>	<p> 529 0317 10  529 0353 10  532 0534 10  534 0281 10  535 0080 10  535 0153 10  538 0397 10  420 0086 10  422 0078 10  821 0865 10  821 0868 10   713 6450 40   713 6450 50  818 0482 10  818 0475 10  825 0333 10  825 0332 10  840 0394 10  840 1143 10  840 1142 10</p>
<p>2.3 CDTI FWD (JV) M9T 870; (81kW)</p>	<p>05.14-</p>	<p></p>	<p>; A/C ; A/C  ; A/C   # F-236675.XX F-561464.XX # F-552305.XX 16x  12 mm 16x FAG  right  left   90 mm</p>	<p> 529 0317 10  529 0353 10  532 0534 10  534 0281 10  535 0080 10  535 0153 10  420 0086 10  422 0078 10  821 0865 10  821 0868 10   713 6450 40</p>



			SCHAEFFLER
--	--	--	-------------------

VAUXHALL

MOVANO Mk II (B)					
2.3 CDTI FWD (JV) M9T 870; (81kW)	05.14-	FAG	  713 6450 50		
			 80 mm		
			 ↔		
			 ↔		
			 right		
			 left		
			 ↔		
			 right		
			 left		
			 		
			 		
			 		
			 		
			 		
2.3 CDTI FWD (UV, EV) M9T 870; (81kW)	05.14-	FAG	 right		
			 left		
			 90 mm		
			 80 mm		
			 ↔		
			 ↔; 		
			 right		
			 left		
			 ↔		
			 right		
			 left		
			 		
			 		
			 ↔		
		 ↔; 			
		 right			
		 left			
		 ↔			
		 right			
		 left			
		LUK	05.10-		  ;  PF6;  N° 0##
					incl.  ; incl.  ; SAC
					  ;  PF6
					  ;  PA0 Easytronic
					  ;  PF6;  N° 0##
					SAC
					incl. 
					 
 					
 					
 					
 					
 					
 					
FAG	05.10-		 		
			 		
			 		
			 		
			 		
			 		
			 		
			 		
			 		
					
					
					
					
					



			SCHAEFFLER
--	---	--	-------------------

VAUXHALL

MOVANO Mk II (B)

2.3 CDTI RWD (FV)
 M9T 686; M9T 690; M9T 692;
 M9T 694; M9T 696; M9T 698; M9T
 876; (92-107kW)

05.10-

	ZF4		626 3050 00
	incl.		415 0490 10
	; A/C		529 0352 10
	; A/C		529 0353 10
	; A/C		532 0534 10
			534 0281 10
			535 0080 10
	# F-236675.XX F-561464.XX		535 0153 10
	# F-552305.XX		538 0397 10
	16x		420 0086 10
	12 mm		
	16x		422 0078 10
	1x		558 0060 10
	1x		559 0172 10
	1x		559 0172 30
FAG	right		821 0865 10
	left		821 0868 10
			713 6450 40
	90 mm		
	; RWD;		713 6450 30
	; RWD;		713 6451 60
	; 4WD		
	90 mm		
			818 0482 10
			818 0475 10
			818 0492 10
	right; 07.10→		825 0333 10
	left		825 0332 10
	right; →07.10		
			840 0394 10
	right		840 1143 10
	left		840 1142 10

2.3 CDTI RWD (UV, HV, EV)
 M9T 686; M9T 690; M9T 692;
 M9T 694; M9T 696; M9T 698; M9T
 876; M9T 890; M9T 898; (92-107kW)

07.10-

	ZF4		626 3050 00
	incl.		415 0490 10
	; A/C		529 0352 10
	; A/C		529 0353 10
	; A/C		532 0534 10
			534 0281 10
	# F-236675.XX F-561464.XX		535 0080 10
	# F-552305.XX		535 0153 10
			538 0397 10
	16x		420 0086 10
	12 mm		
	16x		422 0078 10
	1x		558 0060 10
	1x		559 0172 10
	1x		559 0172 30
FAG	right		821 0865 10
	left		821 0868 10
			713 6450 40
	90 mm		
	; RWD;		713 6450 30
	; RWD;		713 6451 60
	; 4WD		
	90 mm		
			818 0482 10
			818 0475 10
			818 0492 10
	right		825 0333 10
	left		825 0332 10
			840 0394 10
	right		840 1143 10
	left		840 1142 10

2.3 CDTI FWD (FV)
 M9T 704; (96kW)

10.16-













































































































































	SAC		626 3049 33
--	-----	--	-------------



			SCHAEFFLER
--	--	--	-------------------

VAUXHALL

MOVANO Mk II (B)

2.3 CDTI FWD (FV) M9T 704; (96kW)	10.16-		 ; A/C		529 0355 10	
			 ; A/C		529 0356 10	
					532 0534 10	
					534 0281 10	
					535 0080 10	
				535 0153 10		
		FAG	 right		821 0865 10	
			 left		821 0868 10	
					713 6450 40	
			 90 mm		713 6450 50	
			 80 mm			
			 ↔		818 0482 10	
			 ↔; 		818 0475 10	
			 ↔		840 0394 10	
			 right		840 1143 10	
 left			840 1142 10			
2.3 CDTI FWD (UV, HV, EV) M9T 704; (96kW)	10.16-		SAC		626 3049 33	
				 ; A/C		529 0355 10
				 ; A/C		529 0356 10
						532 0534 10
						534 0281 10
					535 0080 10	
				535 0153 10		
		FAG	 right		821 0865 10	
			 left		821 0868 10	
					713 6450 40	
			 90 mm		713 6450 50	
			 80 mm			
			 ↔		818 0482 10	
			 ↔; 		818 0475 10	
			 right		825 0333 10	
 left			825 0332 10			
 ↔			840 0394 10			
 right		840 1143 10				
 left		840 1142 10				
2.3 CDTI RWD (FV) M9T 710; (96kW)	10.16-		 ; A/C		529 0354 10	
			 ; A/C		529 0356 10	
					532 0534 10	
					534 0281 10	
					535 0080 10	
				535 0153 10		
		FAG	 right		821 0865 10	
			 left		821 0868 10	
					713 6450 40	
			 90 mm		713 6450 30	
			 ; RWD ; 		713 6451 60	
			 ; RWD ; 			
			 ; 4WD			
			 90 mm			
			 ↔		818 0482 10	
 ↔; 			818 0475 10			
 ↔; 		818 0492 10				
 ↔		840 0394 10				
 right		840 1143 10				
 left		840 1142 10				
2.3 CDTI RWD (UV, HV) M9T 700; M9T 710; (96-120kW)	05.14-		 ; A/C		529 0354 10	
			 ; A/C		529 0356 10	
					532 0534 10	
					534 0281 10	
					535 0080 10	
				535 0153 10		
		FAG	 right		821 0865 10	
			 left		821 0868 10	
					713 6450 40	
			 90 mm		713 6450 30	
			 ; RWD ; 			



			SCHAEFFLER
--	---	--	-------------------

VAUXHALL

MOVANO Mk II (B)

2.3 CDTI RWD (UV, HV)
 M9T 700; M9T 710; (96-120kW)

05.14-

FAG



 ; RWD ; 

 ; 4WD

 90 mm

 ↔

 ↔ ; 

 ↔ ; 

 right

 left

 ↔

 right

 left

 SAC

 **Set**

713 6451 60

 ↔

818 0482 10

 ↔ ; 

818 0475 10

 ↔ ; 

818 0492 10

 right

825 0333 10

 left

825 0332 10

 ↔

840 0394 10

 right

840 1143 10

 left

840 1142 10

 SAC

626 3049 33

2.3 CDTI FWD (FV)
 M9T 702; M9T 716; (100kW)

05.14-

LUK





 ; A/C

 ; A/C





 # F-236675.XX F-561464.XX

 # F-552305.XX



16x

 12 mm

16x

FAG

 right

 left

 90 mm

 80 mm

 ↔

 right

 left

 ↔

 right

 left

 SAC

 ; A/C

529 0355 10

 ; A/C

529 0356 10



532 0534 10



534 0281 10

 # F-236675.XX F-561464.XX

535 0080 10

 # F-552305.XX

535 0153 10



538 0397 10

16x

420 0086 10

 12 mm

422 0078 10

16x

422 0078 10

 right

821 0865 10

 left

821 0868 10

 **Set**

713 6450 40

 **Set**

713 6450 50

 ↔

818 0482 10

 right

825 0333 10

 left

825 0332 10

 ↔

840 0394 10

 right

840 1143 10

 left

840 1142 10

 SAC

626 3049 33

2.3 CDTI FWD (JV)
 M9T 702; (100-120kW)

05.14-

LUK





 ; A/C

 ; A/C





 # F-236675.XX F-561464.XX

 # F-552305.XX



16x

 12 mm

16x

FAG

 right

 left

 90 mm

 80 mm

 ↔

 ↔

 right

 left

 ↔

 right

 left

 SAC

 ; A/C

529 0355 10

 ; A/C

529 0356 10



532 0534 10



534 0281 10

 # F-236675.XX F-561464.XX

535 0080 10

 # F-552305.XX

535 0153 10



420 0086 10

16x

422 0078 10

 12 mm

422 0078 10

16x

422 0078 10

 right

821 0865 10

 left

821 0868 10

 **Set**

713 6450 40

 **Set**

713 6450 50

 ↔

818 0482 10

 ↔

818 0475 10

 right

825 0333 10

 left

825 0332 10

 ↔

840 0394 10

 right

840 1143 10

 left

840 1142 10

 SAC

626 3049 33

2.3 CDTI FWD (UV, HV)
 M9T 702; M9T 716; (100kW)

05.14-

LUK





 ; A/C

 ; A/C





 # F-236675.XX F-561464.XX

 # F-552305.XX



90 mm

80 mm

FAG

 **Set**

713 6450 40

 **Set**

713 6450 50



			SCHAEFFLER	
--	--	--	-------------------	--

VAUXHALL

MOVANO Mk II (B)				
2.3 CDTI FWD (UV, HV) M9T 702; M9T 716; (100kW)	05.14-	FAG	↔ ↔; ↔ right left	818 0482 10 818 0475 10 840 0394 10 840 1143 10 840 1142 10 626 3049 09
2.3 CDTI RWD (FV) M9T 700; M9T 702; (100kW)	05.14-	LUK	M9T-702 SAC SAC	626 3049 33 529 0354 10 529 0355 10 529 0356 10 532 0534 10 534 0281 10 535 0080 10 535 0153 10 538 0397 10 420 0086 10
2.3 CDTI RWD (UV, HV) M9T 700; (100kW)	05.14-	INA	; M9T 700; A/C ; M9T 702; A/C ; A/C F-236675.XX F-561464.XX F-552305.XX 16x 12 mm 16x FAG right left 90 mm ; RWD; ; RWD; ; 4WD 90 mm ↔ ↔; ↔; ↔ right left ↔ right left	529 0354 10 529 0356 10 532 0534 10 534 0281 10 535 0080 10 535 0153 10 713 6450 40 713 6450 30 713 6451 60 818 0482 10 818 0475 10 818 0492 10 825 0333 10 825 0332 10 840 0394 10 840 1143 10 840 1142 10
2.3 CDTI RWD (UV, HV, EV) M9T 700; (100kW)	05.14-	INA	; A/C ; A/C F-236675.XX F-561464.XX F-552305.XX	529 0354 10 529 0356 10 532 0534 10 534 0281 10 535 0080 10 535 0153 10 713 6450 40 713 6450 30 713 6451 60 818 0482 10 818 0475 10 818 0492 10 840 0394 10 840 1143 10 840 1142 10
2.3 CDTI FWD (UV, HV, EV) M9T 678; M9T 680; (107kW)	05.10-	LUK	MANU; PF6; N° 0## incl. ; incl. ; SAC MANU; PF6 SEMI; PA0 Easytronic SAC MANU; PF6; N° 0## SAC incl.	600 0235 00 626 3049 09 626 3049 33 415 0485 10
2.3 CDTI FWD (UV, HV, EV) M9T 678; M9T 680; (107kW)	05.10-	INA	; A/C ; A/C ; A/C F-236675.XX F-561464.XX F-552305.XX	529 0317 10 529 0353 10 532 0534 10 534 0281 10 535 0080 10 535 0153 10



			SCHAEFFLER
--	--	--	-------------------























VAUXHALL

MOVANO Mk II (B)

2.3 CDTI FWD (UV, HV, EV)
 M9T 678; M9T 680; (107kW)

05.10-

































16x		538 0397 10
 12 mm		420 0086 10
16x		422 0078 10
1x		558 0060 10
1x		559 0172 10
1x		559 0172 30
FAG right		821 0865 10
FAG left		821 0868 10
 90 mm		713 6450 40
 80 mm		713 6450 50
 ↔		818 0482 10
 ↔		818 0475 10
FAG right		825 0333 10
FAG left		825 0332 10
 ↔		840 0394 10
FAG right		840 1143 10
FAG left		840 1142 10

2.3 CDTI FWD (FV)
 M9T 700; (120kW)

05.14-











































 ; A/C		529 0354 10
 ; A/C		529 0356 10
		532 0534 10
		534 0281 10
## F-236675.XX F-561464.XX		535 0080 10
## F-552305.XX		535 0153 10
		538 0397 10
16x		420 0086 10
 12 mm		
16x		422 0078 10
FAG right		821 0865 10
FAG left		821 0868 10
 90 mm		713 6450 40
 80 mm		713 6450 50
 ↔		818 0482 10
 ↔		818 0475 10
FAG right		825 0333 10
FAG left		825 0332 10
 ↔		840 0394 10
FAG right		840 1143 10
FAG left		840 1142 10

2.3 CDTI RWD (FV)
 M9T 700; (120kW)

05.14-



 ; A/C		529 0354 10
 ; A/C		529 0356 10
		532 0534 10
		534 0281 10
## F-236675.XX F-561464.XX		535 0080 10
## F-552305.XX		535 0153 10
16x		420 0086 10
 12 mm		
16x		422 0078 10
FAG right		821 0865 10
FAG left		821 0868 10
 90 mm		713 6450 40
 ; RWD ; 		713 6450 30
 ; RWD ; 		713 6451 60
 ; 4WD		
 90 mm		
 ↔		818 0482 10
 ↔ ; 		818 0475 10
 ↔ ; 		818 0492 10
FAG right		825 0333 10
FAG left		825 0332 10
 ↔		840 0394 10
FAG right		840 1143 10
FAG left		840 1142 10





VAUXHALL

MOVANO Mk II (B)

2.3 CDTI FWD (JV)
 M9T 706; (125kW)

07.15-	 	SAC		626 3049 09
		; A/C		529 0355 10
		; A/C		529 0356 10
				532 0534 10
				534 0281 10
		# F-236675.XX F-561464.XX		535 0080 10
		# F-552305.XX		535 0153 10
		16x		420 0086 10
		12 mm		
		16x		422 0078 10
	FAG	right		821 0865 10
		left		821 0868 10
				713 6450 40
		90 mm		
		80 mm		713 6450 50
		↔		818 0482 10
		↔		818 0475 10
		right		825 0333 10
		left		825 0332 10
		↔		840 0394 10
right		840 1143 10		
left		840 1142 10		

2.3 CDTI FWD (FV)
 M9T 706; (125kW)

11.16-	 	SAC		626 3049 09
		; A/C		529 0355 10
		; A/C		529 0356 10
				532 0534 10
				534 0281 10
		# F-236675.XX F-561464.XX		535 0080 10
		# F-552305.XX		535 0153 10
		right		821 0865 10
		left		821 0868 10
				713 6450 40
	90 mm			
	80 mm		713 6450 50	
	↔		818 0482 10	
	↔;		818 0475 10	
	↔		840 0394 10	
	right		840 1143 10	
	left		840 1142 10	

2.3 CDTI FWD (UV, HV)
 M9T 706; (125kW)

11.16-	 	SAC		626 3049 09
		; A/C		529 0355 10
		; A/C		529 0356 10
				532 0534 10
				534 0281 10
		# F-236675.XX F-561464.XX		535 0080 10
		# F-552305.XX		535 0153 10
		right		821 0865 10
		left		821 0868 10
				713 6450 40
	90 mm			
	80 mm		713 6450 50	
	↔		818 0482 10	
	↔;		818 0475 10	
	↔		840 0394 10	
	right		825 0333 10	
	left		825 0332 10	
	↔		840 0394 10	
	right		840 1143 10	
	left		840 1142 10	

VIVARO A Box (X83)

1.9 DI
 F9Q 762; (59kW)































































08.01-12.06		G5 ; PK5.019 PK5.063 PK5.069		462 0155 10
		G5 ; PK5.011 PK5.013		462 0202 10
		→C039090		624 3087 09
		→C039090; →05.05; PK5 ; N° 0##		624 3087 33
		→C039090; 06.05→; PK5 ; N° 3##		624 3087 34



			SCHAEFFLER
--	---	--	-------------------

VAUXHALL

VIVARO A Box (X83)











































































































































<p>1.9 DI F9Q 762; (59kW)</p>	<p>08.01-12.06</p>	<p></p>	<p>→ C039091 →</p>		624 3312 09	
			<p>→ C039091 →; →05.05; → PK5; → N° 0##</p>		624 3312 33	
			<p>→ C039091 →; 06.05 →; → PK5.3##</p>		624 3312 34	
			<p></p>			530 0196 10
						530 0196 30
						533 0087 20
				<p>→; + →; →02.02; A/C</p>		529 0118 10
				<p>→; 02.02 →; A/C</p>		529 0124 10
				<p>→; A/C</p>		529 0427 10
				<p>→; -e</p>		
				<p>→; →02.02</p>		532 0243 10
				<p>→; A/C</p>		532 0333 10
				<p>→; 02.02 →</p>		532 0364 20
				<p>→; A/C</p>		534 0142 30
				<p>→# F-560843.XX F-556602.XX F-229643.XX</p>		535 0030 10
		<p>→# F-234637.XX</p>			535 0048 10	
		<p>A/C</p>			544 0089 10	
		<p>A/C</p>			544 0101 10	
		<p>A/C</p>			544 0101 20	
		<p>→; A/C</p>			FB 6PK1795	
					538 0392 10	
		<p>FAG</p>			821 0490 10	
			<p>→6V699999; 6Y999999; → right</p>		821 0822 10	
			<p>right; →7V600001; 7Y000001 →</p>		821 0489 10	
			<p>→6V699999; 6Y999999; → left</p>		821 0821 10	
			<p>left; →7V600001; 7Y000001 →</p>		713 6441 20	
			<p>→; ABS; →3V613233</p>		Set	
			<p>86 mm</p>			
			<p>→; ABS; →3V613233</p>		Set	
			<p>86 mm</p>			
			<p>→; 3V613234 →</p>		Set	
			<p>88 mm</p>			
			<p>68 mm</p>		Set	
<p>→ left</p>			771 0507 30			
<p>→</p>			814 0135 10			
<p>↔</p>			818 0207 10			
<p>→</p>			825 0260 10			
<p>→</p>			840 0274 10			
<p>right</p>			840 0880 10			
<p>left</p>		840 0879 10				
<p>1.9 DTI F9Q 760; (74kW)</p>	<p>08.01-12.06</p>	<p></p>	<p>G6;</p>	GearBOX	462 0155 10	
			<p>→ PK6.008 PK6.021 PK6.023 PK6.025 PK6.031 PK6.071 PK6.073 PK6.075 PK6.081</p>			
			<p>G6; → PK6.371 PK6.373 PK6.375</p>	GearBOX	462 0203 10	
			<p>→ C092128</p>		624 3087 09	
			<p>→ C092128; → MANU; → PK5 PK6; → N° 0##</p>		624 3087 33	
			<p>→ C092128; → SEMI; → Easytronic PA6; → N° 0##</p>		624 3087 34	
			<p>→ C092128; → MANU; → PK5 PK6; → N° 3##</p>		624 3087 34	
			<p>C092129 →</p>		624 3312 09	
			<p>C092129 →; → MANU; → PK5 PK6; → N° 0##</p>		624 3312 33	
			<p>C092129 →; → SEMI; → Easytronic PA6; → N° 0##</p>		624 3312 34	
			<p>C092129 →; → PK5.3## PK6.3##</p>		624 3312 34	
			<p>C092129 →; → PF6.0##</p>		530 0196 10	
			<p></p>			530 0196 30
						533 0087 20
				<p>→; + →; →02.02; A/C</p>		529 0118 10
		<p>→; 02.02 →; A/C</p>			529 0124 10	
		<p>→; A/C</p>			529 0427 10	
		<p>→; -e</p>				
		<p>→; →02.02</p>			532 0243 10	
		<p>→; A/C</p>			532 0333 10	
		<p>→; 02.02 →</p>			532 0364 20	
		<p>→; A/C</p>			534 0142 30	
		<p>→# F-560843.XX F-556602.XX F-229643.XX</p>			535 0030 10	
		<p>→# F-234637.XX</p>			535 0048 10	
		<p>A/C</p>		544 0089 10		
		<p>A/C</p>		544 0101 10		



			SCHAEFFLER
--	--	--	-------------------

VAUXHALL

VIVARO A Box (X83)



























































<p>1.9 DTI  F9Q 760; (74kW)</p>	<p>08.01-12.06</p>	<p></p>	A/C		544 0101 20
			 ; A/C		FB 6PK1795
					538 0392 10
			FAG  →6V699999; 6Y999999;  right		821 0490 10
			 right;  7V600001; 7Y000001→		821 0822 10
			 →6V699999; 6Y999999;  left		821 0489 10
			 left;  7V600001; 7Y000001→		821 0821 10
			 ; ABS ;  →3V613233		713 6441 20
			 86 mm		
			 ; ABS ;  →3V613233		713 6441 30
			 86 mm		
			 ;  3V613234→		713 6442 90
			 88 mm		
			 68 mm		713 6441 40
			  left		771 0507 30
					814 0135 10
			 ←		818 0207 10
					825 0260 10
		840 0274 10			
 right		840 0880 10			
 left		840 0879 10			
<p>2.0 CDTI  M9R 630; M9R 692; M9R 780; M9R 782; M9R 786; (66kW)</p>	<p>01.06-07.14</p>	<p></p>			624 3476 09
			 PF6.0##		624 3476 34
					532 0534 10
					534 0281 10
			 # F-236675.XX F-561464.XX		535 0080 10
			 ; PTO ; A/C		FB 7PK1741
			 ; A/C ; PTO ; # OE 93161809 4431667		FB 7PK1973
			 ; A/C ; PTO		
			 ; PTO ; A/C ; # OE 93198427 4434866		FB 7PK2000
					538 0397 10
			16x		420 0086 10
			 12 mm		
			16x		422 0078 10
			1x		558 0059 10
			1x		559 0171 10
			1x		559 0171 30
			FAG  →6V699999; 6Y999999;  right		821 0490 10
			 right;  7V600001; 7Y000001→		821 0822 10
			 →6V699999; 6Y999999;  left		821 0489 10
			 left;  7V600001; 7Y000001→		821 0821 10
			 ; ABS ;  →3V613233		713 6441 20
			 86 mm		
			 ; ABS ;  →3V613233		713 6441 30
			 86 mm		
 ;  3V613234→		713 6442 90			
 88 mm					
 68 mm		713 6441 40			
		814 0135 10			
 ←		818 0207 10			
		825 0260 10			
 7V621198 7Y721613→; 		825 0261 10			
		840 0274 10			
 right		840 0880 10			
 left		840 0879 10			
<p>2.0 CDTI  M9R 630; M9R 692; M9R 780; M9R 788; (84kW)</p>	<p>08.06-07.14</p>	<p></p>			624 3476 09
			 PF6.0##		624 3476 34
					529 0317 10
			 ;  M9R 630		
			 ;  M9R 692		
			 ;  M9R 780		
			 ;  M9R 786		
			 ;  M9R 788		
					532 0534 10
					534 0281 10
 # F-236675.XX F-561464.XX		535 0080 10			
 ; PTO ; A/C		FB 7PK1741			



			SCHAEFFLER
--	---	--	-------------------

VAUXHALL

VIVARO A Box (X83)































































































2.0 CDTI M9R 630; M9R 692; M9R 780; M9R 788; (84kW)	08.06-07.14		111; A/C; PTO; # OE 93161809 4431667 111; A/C; PTO		FB 7PK1973	
			111; PTO; A/C; # OE 93198427 4434866		FB 7PK2000	
			16x		538 0397 10	
			12 mm 16x		420 0086 10	
			16x		422 0078 10	
			1x		558 0059 10	
			1x		559 0171 10	
			1x		559 0171 30	
		FAG	→6V699999; 6Y999999; right right; 7V600001; 7Y000001→		821 0490 10	
			→6V699999; 6Y999999; left left; 7V600001; 7Y000001→		821 0822 10	
			; ABS; →3V613233 86 mm		821 0489 10	
			; ABS; →3V613233 86 mm		821 0821 10	
			; →3V613233 86 mm		713 6441 20	
			; →3V613233 86 mm		713 6441 30	
			; →3V613234 88 mm		713 6442 90	
			; →3V613234 88 mm		713 6441 40	
			; 86 mm		814 0135 10	
			; 86 mm		818 0207 10	
			; 86 mm		825 0260 10	
			; 86 mm		825 0261 10	
			; 86 mm		840 0274 10	
			; 86 mm		840 0880 10	
			; 86 mm		840 0879 10	
2.0 ECOTEC F4R 820; (86kW)	08.06-07.14			G6; PK6.009 PK6.022 PK6.026 PK6.072 PK6.076 G6; PK6.372 PK6.375 PK6.376	GearBOX	462 0155 10
					GearBOX	462 0203 10
					530 0638 10	
					530 0638 30	
					531 0630 30	
					532 0654 10	
					529 0124 10	
					532 0364 20	
					534 0240 10	
					535 0030 10	
					535 0048 10	
					538 0392 10	
					420 0099 10	
				16x		422 0009 10
				12 mm		422 0009 10
				16x		821 0490 10
			FAG	→6V699999; 6Y999999; right right; 7V600001; 7Y000001→		821 0822 10
				→6V699999; 6Y999999; left left; 7V600001; 7Y000001→		821 0489 10
				; ABS; →3V613233 86 mm		821 0821 10
		; ABS; →3V613233 86 mm			713 6441 20	
		; →3V613233 86 mm			713 6441 30	
		; →3V613234 88 mm			713 6442 90	
		; →3V613234 88 mm			713 6441 40	
		; 86 mm			771 0507 30	
		; 86 mm			814 0135 10	
		; 86 mm			818 0207 10	
		; 86 mm			825 0261 10	
		; 86 mm			840 0274 10	
		; 86 mm			840 0880 10	
		; 86 mm			840 0879 10	
2.0 16V F4R 720; (88kW)	08.01-12.06			G6; PK6.009 PK6.022 PK6.026 PK6.072 PK6.076 G6; PK6.372 PK6.375 PK6.376	GearBOX	462 0155 10
					GearBOX	462 0203 10
						624 3092 09
			10.05→; PK6; № 3## →09.05; PK6; № 0##		624 3092 33	
					624 3092 34	



			SCHAEFFLER
--	--	--	-------------------

VAUXHALL

VIVARO A Box (X83)











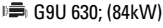



































































































































2.0 16V F4R 720; (88kW)	08.01-12.06		 530 0638 10			
			 530 0638 30			
			 531 0630 30			
			 532 0654 10			
			 529 0118 10			
			 529 0124 10			
			 532 0243 10			
			 532 0364 20			
			 534 0142 30			
			 534 0240 10			
			 535 0030 10			
			 535 0048 10			
			 FB 5PK1125			
			 FB 6PK1795			
			 538 0392 10			
			 420 0099 10			
			16x  12 mm			
			16x  422 0009 10			
		FAG	 →6V699999; 6Y999999; right	 821 0490 10		
			 right; →7V600001; 7Y000001→	 821 0822 10		
			 →6V699999; 6Y999999; left	 821 0489 10		
			 left; →7V600001; 7Y000001→	 821 0821 10		
			 ; ABS ; →3V613233  86 mm	 Set 713 6441 20		
			 ; ABS ; →3V613233  86 mm	 Set 713 6441 30		
			 ; →3V613234→  88 mm	 Set 713 6442 90		
			 68 mm	 Set 713 6441 40		
			 left	 771 0507 30		
				 814 0135 10		
			 ←	 818 0207 10		
				 825 0260 10		
				 840 0274 10		
			 right	 840 0880 10		
			 left	 840 0879 10		
2.5 CDTI G9U 630; (84kW)	08.06-08.08			 →C022528; MANU	 623 3159 09	
		SAC  C022529→; MANU		 624 3945 09		
		 C022529→; MANU ; PK6 ; № 3##		 624 3945 33		
		 C022529→; MANU ; PK6 ; № 0##		 624 3945 34		
		 →4V644188 incl. 		 415 0146 10		
					 530 0198 10	
					 531 0548 10	
					 532 0313 20	
					 MY 2011; A/C ; OPTION	 529 0437 10
					 MY 2011; e ; OPTION	
		 A/C	 532 0333 10			
		 MY 2011; A/C	 532 0364 20			
		 MY 2011; A/C	 532 0534 10			
		 A/C	 534 0181 10			
		 e				
		 A/C	 534 0317 10			
		 e				
		A/C	 544 0098 10			
		 A/C	 FB 7PK1113			
		 e				
		 A/C	 FB 7PK1795			
		 e				
		 A/C ; OPTION	 FB 7PK1835			
		 e ; OPTION				
		1x; 	 428 0185 10			
		1x;	428 0186 10			
		FAG	; ABS ; →3V613233 86 mm	Set 713 6441 20		
			; ABS ; →3V613233 86 mm	Set 713 6441 30		



			SCHAEFFLER
--	---	--	-------------------

VAUXHALL

VIVARO A Box (X83)

2.5 CDTI 	08.06-08.08	FAG	 3V613234→	 Set	713 6442 90			
			 88 mm	 Set	713 6441 40			
			 68 mm	 →	818 0207 10			
			 ↔	 →	840 0274 10			
			 right	 →	840 0880 10			
			 left	 →	840 0879 10			
			LUK	07.03-07.14	G6 ;  PK6.007 PK6.027 PK6.028	GearBOX	462 0155 10	
						G6 ;  PK6.024	GearBOX	462 0202 10
						 G9U 730;  → C022528;  MANU		623 3159 09
						 G9U 730;  C022529→;  MANU		624 3945 09
						 G9U 730;  C022529→;  MANU ;  PK6 ;  № 3##		624 3945 33
						 G9U 730;  C022529→;  MANU ;  PK6 ;  № 0##		624 3945 34
						 G9U 730;  →4V644188		415 0146 10
						incl. 		
								
	531 0548 10							
	532 0313 20							
	529 0436 10							
 ; A/C ; OPTION								
 ;  ; OPTION								
 ; A/C		532 0333 10						
		532 0364 20						
 ; A/C		534 0181 10						
 ; 		534 0317 10						
 ; 								
 # F-560843.XX F-556602.XX F-229643.XX		535 0030 10						
 G9U 630		535 0081 10						
 # F-238512.XX								
A/C		544 0094 10						
 ; A/C		FB 6PK1148						
 ; 								
 ; A/C		FB 6PK1795						
 ; 		538 0374 10						
16x		420 0063 10						
 11 mm								
1x; 		428 0185 10						
1x; 		428 0186 10						
FAG			 →6V699999; 6Y999999;  right		821 0490 10			
			 right;  7V600001; 7Y000001→		821 0822 10			
			 →6V699999; 6Y999999;  left		821 0489 10			
			 left;  7V600001; 7Y000001→		821 0821 10			
			 ; ABS ;  →3V613233	 Set	713 6441 20			
			 86 mm					
			 ; ABS ;  →3V613233	 Set	713 6441 30			
			 86 mm					
			 ;  3V613234→	 Set	713 6442 90			
			 88 mm					
			 68 mm	 Set	713 6441 40			
					814 0135 10			
			 ↔		818 0207 10			
					825 0260 10			
			 7V621198 7Y721613→; 		825 0261 10			
		840 0274 10						
 right		840 0880 10						
 left		840 0879 10						
LUK	08.06-07.14		 → C022528;  MANU		623 3159 09			
			SAC					
			 C022529→;  MANU		624 3945 09			
			 C022529→;  MANU ;  PK6 ;  № 3##		624 3945 33			
			 C022529→;  MANU ;  PK6 ;  № 0##		624 3945 34			
			 →4V644188		415 0146 10			
incl.								
				530 0198 10				
				531 0548 10				



























































			SCHAEFFLER
--	--	--	-------------------

VAUXHALL

VIVARO A Box (X83)

2.5 CDTI
 F90 630; (107kW)

























08.06-07.14

	MY 2011; A/C ; OPTION		532 0313 20
	MY 2011; -e ; OPTION		529 0437 10
	A/C		532 0333 10
	MY 2011; A/C		532 0364 20
	MY 2011; A/C		532 0534 10
	A/C		534 0181 10
	-e		534 0317 10
	A/C		534 0317 10
	-e		534 0317 10
	F-560843.XX F-556602.XX F-229643.XX		535 0030 10
	F-238512.XX		535 0081 10
	A/C		544 0098 10
	A/C		FB 7PK1113
	-e		FB 7PK1113
	A/C		FB 7PK1795
	-e		FB 7PK1795
	A/C ; OPTION		FB 7PK1835
	-e ; OPTION		FB 7PK1835
	16x		538 0374 10
	11 mm		420 0063 10
	1x; 		428 0185 10
	1x; 		428 0186 10
	FAG  → 6V699999; 6Y999999;  right		821 0490 10
	 right;  7V600001; 7Y000001 →		821 0822 10
	 → 6V699999; 6Y999999;  left		821 0489 10
	 left;  7V600001; 7Y000001 →		821 0821 10
	 ; ABS ;  → 3V613233		713 6441 20
	86 mm		713 6441 30
	 ; ABS ;  → 3V613233		713 6442 90
	86 mm		713 6442 90
	 ;  3V613234 →		713 6441 40
	88 mm		713 6441 40
	 68 mm		814 0135 10
 ↔		818 0207 10	
		825 0260 10	
 7V621198 7Y721613 →; 		825 0261 10	
		840 0274 10	
right		840 0880 10	
left		840 0879 10	

VIVARO A Combi (X83)

1.9 DI
 F90 762; (59kW)

08.01-12.06















































































































































































	G5 ;  PK5.019 PK5.063 PK5.069		GearBOX	462 0155 10
	G5 ;  PK5.011 PK5.013		GearBOX	462 0202 10
	 → C039090			624 3087 09
	 → C039090; → 05.05;  PK5 ;  N° 0##			624 3087 33
	 → C039090; 06.05 →;  PK5 ;  N° 3##			624 3087 34
	 C039091 →			624 3312 09
	 C039091 →; → 05.05;  PK5 ; N° 0##			624 3312 33
	C039091 →; 06.05 →; PK5.3##			624 3312 34
				530 0196 10
				530 0196 30
			533 0087 20	
	; + ; → 02.02; A/C			529 0118 10
	; 02.02 →; A/C			529 0124 10
	; A/C			529 0427 10
	; -e			532 0243 10
	; → 02.02			532 0333 10
	; A/C			532 0364 20
	; 02.02 →			534 0142 30
	; A/C			535 0030 10
	F-560843.XX F-556602.XX F-229643.XX			535 0048 10
F-234637.XX			544 0089 10	
A/C			544 0101 10	
A/C			544 0101 20	



			SCHAEFFLER
--	---	--	-------------------

VAUXHALL

VIVARO A Combi (X83)

























































<p>1.9 DTI F9Q 762; (59kW)</p>	<p>08.01-12.06</p>	<p> FAG</p>	<p> ; A/C</p>		FB 6PK1795
			<p> →6V699999; 6Y999999;  right</p>		821 0490 10
			<p> right;  7V600001→</p>		821 0822 10
			<p> →6V699999; 6Y999999;  left</p>		821 0489 10
			<p> left;  7V600001→</p>		821 0821 10
			<p> ;  ABS;  →3V613233</p>		713 6441 20
			<p> 86 mm</p>		713 6441 30
			<p> ;  ABS;  →3V613233</p>		713 6441 30
			<p> 86 mm</p>		713 6442 90
			<p> ;  3V613234→</p>		713 6442 90
			<p> 88 mm</p>		713 6441 40
			<p> 68 mm</p>		713 6441 40
			<p> left</p>		771 0507 30
			<p> </p>		814 0135 10
			<p> ↔</p>		818 0207 10
			<p> </p>		825 0260 10
			<p> </p>		840 0274 10
			<p> right</p>		840 0880 10
			<p> left</p>		840 0879 10
			<p>1.9 DTI F9Q 760; (74kW)</p>	<p>08.01-12.06</p>	<p> LUK</p>
<p> PK6.008  PK6.021  PK6.025  PK6.031  PK6.071  PK6.073  PK6.075  PK6.081</p>	GearBOX	462 0203 10			
<p>G6 ;  PK6.371  PK6.373  PK6.375</p>	GearBOX	462 0203 10			
<p> →C092128</p>		624 3087 09			
<p> →C092128;  MANU;  PK5 PK6;  N° 0##</p>		624 3087 33			
<p> →C092128;  SEMI;  Easytronic PA6;  N° 0##</p>		624 3087 34			
<p> →C092128;  MANU;  PK5 PK6;  N° 3##</p>		624 3087 34			
<p> C092129→</p>		624 3312 09			
<p> C092129→;  MANU;  PK5 PK6;  N° 0##</p>		624 3312 33			
<p> C092129→;  SEMI;  Easytronic PA6;  N° 0##</p>		624 3312 33			
<p> C092129→;  MANU;  PK5.3##  PK6.3##</p>		624 3312 34			
<p> C092129→;  MANU;  PF6.0##</p>		624 3312 34			
<p> INA</p>		530 0196 10			
<p> KIT</p>		530 0196 30			
<p> ; +  ; →02.02; A/C</p>		533 0087 20			
<p> ; 02.02→; A/C</p>		529 0118 10			
<p> ; A/C</p>		529 0124 10			
<p> ; - </p>		529 0427 10			
<p> ; →02.02</p>		532 0243 10			
<p> ; A/C</p>		532 0333 10			
<p> ; 02.02→</p>		532 0364 20			
<p> ; A/C</p>		534 0142 30			
<p> F-560843.XX  F-556602.XX  F-229643.XX</p>		535 0030 10			
<p> F-234637.XX</p>		535 0048 10			
<p>A/C</p>		544 0089 10			
<p>A/C</p>		544 0101 10			
<p>A/C</p>		544 0101 20			
<p> ; A/C</p>		FB 6PK1795			
<p></p>		821 0490 10			
<p> →6V699999; 6Y999999;  right</p>		821 0490 10			
<p> right;  7V600001→</p>		821 0822 10			
<p> →6V699999; 6Y999999;  left</p>		821 0489 10			
<p> left;  7V600001→</p>		821 0821 10			
<p> ;  ABS;  →3V613233</p>		713 6441 20			
<p> 86 mm</p>		713 6441 30			
<p> ;  ABS;  →3V613233</p>		713 6441 30			
<p> 86 mm</p>		713 6442 90			
<p> ;  3V613234→</p>		713 6442 90			
<p> 88 mm</p>		713 6441 40			
<p> 68 mm</p>		713 6441 40			
<p> left</p>		771 0507 30			
<p> </p>		814 0135 10			
<p> ↔</p>		818 0207 10			
<p> </p>		825 0260 10			
<p> </p>		840 0274 10			



			SCHAEFFLER
--	--	--	-------------------

VAUXHALL

VIVARO A Combi (X83)























































































































































1.9 DTI F9Q 760; (74kW)	08.01-12.06	FAG	right		840 0880 10
			left		840 0879 10
2.0 CDTI M9R 630; M9R 780; M9R 782; M9R 786; (66kW)	01.06-07.14	LUK			624 3476 09
			PF6.0##		624 3476 34
					532 0534 10
					534 0281 10
			## F-236675.XX F-561464.XX		535 0080 10
			; PTO ; A/C		FB 7PK1741
			; A/C ; PTO ; # OE 93161809 4431667		FB 7PK1973
			; A/C ; PTO		FB 7PK2000
			; PTO ; A/C ; # OE 93198427 4434866		538 0397 10
			16x		420 0086 10
			12 mm		
			16x		422 0078 10
			1x		558 0059 10
			1x		559 0171 10
			1x		559 0171 30
			FAG		821 0490 10
			→6V699999; 6Y999999; right		821 0822 10
			right; 7V600001; 7Y000001→		821 0489 10
			→6V699999; 6Y999999; left		821 0821 10
			left; 7V600001; 7Y000001→		713 6441 20
; ABS ; →3V613233		713 6441 30			
86 mm		713 6442 90			
; ABS ; →3V613233		713 6441 40			
86 mm		814 0135 10			
; 3V613234→		818 0207 10			
88 mm		825 0260 10			
		825 0261 10			
68 mm		840 0274 10			
		840 0880 10			
		840 0879 10			
		624 3476 09			
		624 3476 34			
		529 0317 10			
		532 0534 10			
		534 0281 10			
## F-236675.XX F-561464.XX		535 0080 10			
; PTO ; A/C		FB 7PK1741			
; A/C ; PTO ; # OE 93161809 4431667		FB 7PK1973			
; A/C ; PTO		FB 7PK2000			
; PTO ; A/C ; # OE 93198427 4434866		538 0397 10			
16x		420 0086 10			
12 mm					
16x		422 0078 10			
1x		558 0059 10			
1x		559 0171 10			
1x		559 0171 30			
FAG		821 0490 10			
→6V699999; 6Y999999; right		821 0822 10			
right; 7V600001; 7Y000001→		821 0489 10			
→6V699999; 6Y999999; left		821 0821 10			
left; 7V600001; 7Y000001→		713 6441 20			
; ABS ; →3V613233		713 6441 30			
86 mm		713 6442 90			
; ABS ; →3V613233					
86 mm					
; 3V613234→					
88 mm					



			<p>SCHAEFFLER</p>
--	---	--	--------------------------

VAUXHALL

VIVARO A Combi (X83)







































<p>2.0 CDTI  M9R 630; M9R 780; M9R 784; M9R 786; M9R 788; (84kW)</p>	<p>08.06-07.14</p>	<p>FAG</p>	<p>  Set 713 6441 40</p> <p> 68 mm</p> <p>  814 0135 10</p> <p> ↔  818 0207 10</p> <p>  825 0260 10</p> <p>  825 0261 10</p> <p>  840 0274 10</p> <p> right  840 0880 10</p> <p> left  840 0879 10</p>	
<p>2.0 ECOTEC  F4R 820; (86kW)</p>	<p>08.06-07.14</p>	<p>LUK</p> <p></p>	<p>G6;  PK6.009 PK6.022 PK6.026 PK6.072 PK6.076 GearBOX 462 0155 10</p> <p>G6;  PK6.372 PK6.375 PK6.376 GearBOX 462 0203 10</p> <p>  530 0638 10</p> <p>  530 0638 30</p> <p>  531 0630 30</p> <p>  532 0654 10</p> <p>  529 0124 10</p> <p>  532 0364 20</p> <p>  534 0240 10</p> <p>  535 0030 10</p> <p>  535 0048 10</p> <p>  538 0392 10</p> <p> 420 0099 10</p> <p>16x  422 0009 10</p> <p> 12 mm  422 0009 10</p> <p>16x  422 0009 10</p> <p>FAG  →6V699999; 6Y999999;  right  821 0490 10</p> <p> right;  7V600001; 7Y000001→  821 0822 10</p> <p> →6V699999; 6Y999999;  left  821 0489 10</p> <p> left;  7V600001; 7Y000001→  821 0821 10</p> <p>  ABS;  →3V613233  Set 713 6441 20</p> <p> 86 mm  Set 713 6441 30</p> <p>  ABS;  →3V613233  Set 713 6442 90</p> <p> 86 mm  Set 713 6442 90</p> <p>  3V613234→  Set 713 6441 40</p> <p> 88 mm  Set 713 6441 40</p> <p> 68 mm  Set 713 6441 40</p> <p> left  771 0507 30</p> <p>  814 0135 10</p> <p> ↔  818 0207 10</p> <p>  825 0261 10</p> <p>  840 0274 10</p> <p> right  840 0880 10</p> <p> left  840 0879 10</p>	
<p>2.0 16V  F4R 720; (88kW)</p>	<p>08.01-12.06</p>	<p>LUK</p> <p></p>	<p>G6;  PK6.009 PK6.022 PK6.026 PK6.072 PK6.076 GearBOX 462 0155 10</p> <p>G6;  PK6.372 PK6.375 PK6.376 GearBOX 462 0203 10</p> <p>  624 3092 09</p> <p>10.05→;  PK6;  № 3##  624 3092 33</p> <p>→09.05;  PK6;  № 0##  624 3092 34</p> <p>  530 0638 10</p> <p>  530 0638 30</p> <p>  531 0630 30</p> <p>  532 0654 10</p> <p>  529 0118 10</p> <p>  529 0124 10</p> <p>  532 0243 10</p> <p>  532 0364 20</p> <p>  534 0142 30</p> <p>  534 0240 10</p> <p>  535 0030 10</p> <p>  535 0048 10</p> <p>   FB 5PK1125</p> <p>   FB 6PK1795</p> <p>  538 0392 10</p> <p> 420 0099 10</p> <p>16x  422 0009 10</p> <p> 12 mm  422 0009 10</p> <p>16x  422 0009 10</p> <p>FAG  →6V699999; 6Y999999;  right  821 0490 10</p> <p> right;  7V600001; 7Y000001→  821 0822 10</p> <p> →6V699999; 6Y999999;  left  821 0489 10</p>	



			SCHAEFFLER
--	--	--	-------------------

VAUXHALL

VIVARO A Combi (X83)

2.0 16V F4R 720; (88kW)	08.01-12.06	FAG	left; 7V600001; 7Y000001 →	 821 0821 10			
			ABS; →3V613233	 713 6441 20			
			86 mm				
			ABS; →3V613233	 713 6441 30			
			86 mm				
			3V613234 →	 713 6442 90			
			88 mm				
			68 mm	 713 6441 40			
			left	 771 0507 30			
			↔	 814 0135 10			
			↔	 818 0207 10			
			right	 825 0260 10			
			left	 840 0274 10			
			right	 840 0880 10			
			left	 840 0879 10			
			2.5 CDTI G9U 630; (84kW)	08.06-07.14	LUK	→C022528; MANU	 623 3159 09
						SAC	
→; MANU	 624 3945 09						
C022529 →; MANU ; PK6 ; N° 3##	 624 3945 33						
C022529 →; MANU ; PK6 ; N° 0##	 624 3945 34						
→4V644188	 415 0146 10						
					 530 0198 10		
					 531 0548 10		
					 532 0313 20		
					 529 0437 10		
					 532 0333 10		
					 532 0364 20		
					 532 0534 10		
					 534 0181 10		
					 534 0317 10		
					 544 0098 10		
					FB 7PK1113		
					FB 7PK1795		
					FB 7PK1835		
					 428 0185 10		
					 428 0186 10		
	FAG					 713 6441 20	
						 713 6441 30	
			 713 6442 90				
			 713 6441 40				
			818 0207 10				
			840 0274 10				
			840 0880 10				
			840 0879 10				
LUK				GearBOX 462 0155 10			
				GearBOX 462 0202 10			
				G9U 730; →C022528; MANU			
				SAC			
				G9U 730; C022529 →; MANU			
				G9U 730; C022529 →; MANU ; PK6 ; N° 3##			
				G9U 730; C022529 →; MANU ; PK6 ; N° 0##			
				G9U 730; →4V644188			
				incl.			
				 530 0198 10			
				 531 0548 10			
				 532 0313 20			



			<p>SCHAEFFLER</p>	
--	---	--	-------------------	--













VAUXHALL

VIVARO A Combi (X83)















2.5 DTI
 G9U 730; (99kW)

07.03-07.14



A/C ; OPTION		529 0436 10
; ; OPTION		
; A/C		532 0333 10
; A/C		532 0364 20
; A/C		534 0181 10
; ;		
; A/C		534 0317 10
; ;		
# F-560843.XX F-556602.XX F-229643.XX		535 0030 10
G9U 630		535 0081 10
# F-238512.XX		
A/C		544 0094 10
; A/C		FB 6PK1148
; ;		
; A/C		FB 6PK1795
; ;		
16x		538 0374 10
11 mm		
1x;		428 0185 10
1x;		428 0186 10





FAG

→6V699999; 6Y999999; right		821 0490 10
right; 7V600001; 7Y000001→		821 0822 10
→6V699999; 6Y999999; left		821 0489 10
left; 7V600001; 7Y000001→		821 0821 10
; ABS; →3V613233		Set 713 6441 20
86 mm		
; ABS; →3V613233		Set 713 6441 30
86 mm		
; 3V613234→		Set 713 6442 90
88 mm		
68 mm		Set 713 6441 40
814 0135 10		
818 0207 10		
825 0260 10		
7V621198 7Y721613→;		825 0261 10
840 0274 10		
right		840 0880 10
left		840 0879 10

















2.5 CDTI
 G9U 630; (107kW)

01.06-07.14



→C022528; MANU		623 3159 09
SAC		
C022529→; MANU		624 3945 09
C022529→; PK6.3##		624 3945 33
C022529→; MANU; PK6; N° 0##		624 3945 34
→4V644188		415 0146 10
incl.		



; MY 2011; A/C ; OPTION		530 0198 10
; MY 2011; ; OPTION		531 0548 10
; A/C		532 0313 20
; MY 2011; A/C		529 0437 10
; MY 2011; A/C		532 0333 10
; MY 2011; A/C		532 0364 20
; MY 2011; A/C		532 0534 10
; A/C		534 0181 10
; ;		
; A/C		534 0317 10
; ;		
# F-560843.XX F-556602.XX F-229643.XX		535 0030 10
# F-238512.XX		535 0081 10
A/C		544 0098 10
; A/C		FB 7PK1113
; ;		
; A/C		FB 7PK1795
; ;		
; A/C ; OPTION		FB 7PK1835
; ; ; OPTION		
538 0374 10		



			SCHAEFFLER
--	--	--	------------

VAUXHALL

VIVARO A Combi (X83)

2.5 CDTI G9U 630; (107kW)	01.06-07.14		16x 11 mm 1x; 1x; FAG → 6V699999; 6Y999999; right right; 7V600001; 7Y000001→ → 6V699999; 6Y999999; left left; 7V600001; 7Y000001→ ; ABS ; → 3V613233 86 mm ; ABS ; → 3V613233 86 mm ; 3V613234→ 88 mm 68 mm ↔ 7V621198 7Y721613→; right left	420 0063 10 428 0185 10 428 0186 10 821 0490 10 821 0822 10 821 0489 10 821 0821 10 713 6441 20 713 6441 30 713 6442 90 713 6441 40 814 0135 10 818 0207 10 825 0261 10 840 0274 10 840 0880 10 840 0879 10
------------------------------	-------------	--	---	---

VIVARO A Platform/Chassis (X83)

1.9 DI F9Q 762; (59kW)	04.03-07.14		G5 ; PK5.019 PK5.063 PK5.069 G5 ; PK5.011 PK5.013 → C039090 → C039090; → 05.05; PK5; N° 0## → C039090; 06.05→; PK5; N° 3## C039091→ C039091→; → 05.05; PK5; N° 0## C039091→; 06.05→; PK5.3## ; A/C ; - ; A/C ; A/C # F-560843.XX F-556602.XX F-229643.XX A/C A/C A/C FAG → 6V699999; 6Y999999; right right; 7V600001; 7Y000001→ → 6V699999; 6Y999999; left left; 7V600001; 7Y000001→ ; ABS ; → 3V613233 86 mm ; ABS ; → 3V613233 86 mm ; 3V613234→ 88 mm 68 mm left ↔ 7V621198 7Y721613→; right left	GearBOX 462 0155 10 GearBOX 462 0202 10 624 3087 09 624 3087 33 624 3087 34 624 3312 09 624 3312 33 624 3312 34 530 0196 10 530 0196 30 533 0087 20 529 0427 10 532 0333 10 532 0364 20 534 0142 30 535 0030 10 544 0089 10 544 0101 10 544 0101 20 538 0392 10 821 0490 10 821 0822 10 821 0489 10 821 0821 10 713 6441 20 713 6441 30 713 6442 90 713 6441 40 771 0507 30 814 0135 10 818 0207 10 825 0261 10 840 0274 10 840 0880 10 840 0879 10
2.0 CDTI M9R 630; M9R 780; M9R 782; M9R 786; (66kW)	01.06-07.14		PF6; N° 0## # F-236675.XX F-561464.XX	624 3476 09 624 3476 34 532 0534 10 534 0281 10 535 0080 10



			<p>SCHAEFFLER</p>
--	---	--	--------------------------





























































VAUXHALL

VIVARO A Platform/Chassis (X83)

2.0 CDTI
 M9R 630; M9R 780; M9R 782;
 M9R 786; (66kW)

01.06-07.14







 ; 	 FB 7PK1741
 ;  ;  ; # OE 93161809 4431667	 FB 7PK1973
 ; 	
 ;  ; # OE 93198427 4434866	 FB 7PK2000
	 538 0397 10
16x	 420 0086 10
 12 mm	
16x	 422 0078 10
1x	 558 0059 10
1x	 559 0171 10
1x	 559 0171 30
FAG	 → 6V699999; 6Y999999;  right
 right;  7V600001; 7Y000001 →	 821 0490 10
 → 6V699999; 6Y999999;  left	 821 0489 10
 left;  7V600001; 7Y000001 →	 821 0821 10
 ;  ;  → 3V613233	 713 6441 20
 86 mm	
 ;  ;  → 3V613233	 713 6441 30
 86 mm	
 ;  3V613234 →	 713 6442 90
 88 mm	
 68 mm	 713 6441 40
	 814 0135 10
	 818 0207 10
	 825 0260 10
 7V621198 7Y721613 →; 	 825 0261 10
	 840 0274 10
 right	 840 0880 10
 left	 840 0879 10













































































2.0 CDTI
 M9R 630; M9R 780; M9R 788;
 (84kW)

08.06-07.14



 PF6 ;  Nº 0##	 624 3476 09
	 624 3476 34



 ;  M9R 630	 529 0317 10
 ;  M9R 692	
 ;  M9R 780	
 ;  M9R 786	
 ;  M9R 788	
	 532 0534 10
	 534 0281 10
 ; # F-236675.XX F-561464.XX	 535 0080 10
 ; 	 FB 7PK1741
 ;  ;  ; # OE 93161809 4431667	 FB 7PK1973
 ; 	 FB 7PK2000
 ;  ; # OE 93198427 4434866	 538 0397 10
	 420 0086 10
16x	 422 0078 10
 12 mm	
16x	 422 0078 10
1x	 558 0059 10
1x	 559 0171 10
1x	 559 0171 30
FAG	 → 6V699999; 6Y999999;  right
 right;  7V600001; 7Y000001 →	 821 0822 10
 → 6V699999; 6Y999999;  left	 821 0489 10
 left;  7V600001; 7Y000001 →	 821 0821 10
 ;  ;  → 3V613233	 713 6441 20
 86 mm	
 ;  ;  → 3V613233	 713 6441 30
 86 mm	
 ;  3V613234 →	 713 6442 90
 88 mm	
 68 mm	 713 6441 40
	 814 0135 10
	 818 0207 10
	 825 0260 10
 7V621198 7Y721613 →; 	 825 0261 10
	 840 0274 10
 right	 840 0880 10





VAUXHALL

VIVARO A Platform/Chassis (X83)



























































































































2.0 CDTI M9R 630; M9R 780; M9R 788; (84kW)	08.06-07.14	FAG	left		840 0879 10	
2.0 ECOTEC F4R 820; (86kW)	08.06-07.14	LUK	G6; PK6.009 PK6.022 PK6.026 PK6.072 PK6.076 G6; PK6.372 PK6.375 PK6.376	GearBOX	462 0155 10 462 0203 10	
						530 0638 10 530 0638 30 531 0630 30 532 0654 10
						529 0124 10
						532 0364 20
						534 0240 10
						535 0030 10
						535 0048 10
						538 0392 10
						420 0099 10
						422 0009 10
		FAG	→6V699999; 6Y999999; right		821 0490 10	
						821 0822 10
						821 0489 10
						821 0821 10
						713 6441 20
						713 6441 30
						713 6442 90
						713 6441 40
						771 0507 30
						814 0135 10
						818 0207 10
						825 0261 10
						840 0274 10
						840 0880 10
						840 0879 10
2.0 16V F4R 720; (88kW)	04.03-07.14	LUK	G6; PK6.009 PK6.072 PK6.076 PK6.022 PK6.026 G6; PK6.372 PK6.375 PK6.376	GearBOX GearBOX	462 0155 10 462 0203 10	
						624 3092 09
						624 3092 33
						624 3092 34
						530 0638 10 530 0638 30 531 0630 30 532 0654 10
						529 0124 10
						534 0240 10
						535 0030 10
						535 0048 10
						538 0392 10
						420 0099 10
						422 0009 10
		FAG	→6V699999; 6Y999999; right		821 0490 10	
						821 0822 10
						821 0489 10
						821 0821 10
						713 6441 20
						713 6441 30
						713 6442 90
						713 6441 40
						771 0507 30
						814 0135 10
						818 0207 10
						825 0261 10



			SCHAEFFLER
--	---	--	-------------------

VAUXHALL

VIVARO A Platform/Chassis (X83)























































































2.0 16V F4R 720; (88kW)	04.03-07.14	FAG	 840 0274 10	
			 right 840 0880 10	
2.5 CDTI G9U 630; (84kW)	08.06-07.14	LUK	 left 840 0879 10	
			 →C022528;  MANU SAC  623 3159 09	
			 C022529 →;  MANU  624 3945 09	
			 C022529 →;  MANU ;  PK6 ;  N° 3##  624 3945 33	
			 C022529 →;  MANU ;  PK6 ;  N° 0##  624 3945 34	
			 →4V644188  415 0146 10	
		INA	 incl.  530 0198 10	
			 531 0548 10	
			 532 0313 20	
			 ; MY 2011; A/C ; OPTION  529 0437 10	
			 ; MY 2011;  ; OPTION  532 0333 10	
			 ; A/C  532 0364 20	
			 ; MY 2011; A/C  532 0534 10	
			 ; A/C  534 0181 10	
			 ;   534 0317 10	
			 ;   544 0098 10	
			 A/C  FB 7PK1113	
			 ; A/C  FB 7PK1795	
			 ;   FB 7PK1835	
			 ; A/C ; OPTION  FB 7PK1835	
			 ;  ; OPTION  428 0185 10	
			 1x;  428 0186 10	
		FAG	 ; ABS ;  →3V613233  713 6441 20	
			 86 mm  713 6441 30	
			 ; ABS ;  →3V613233  713 6442 90	
			 86 mm  713 6441 40	
			 ;  3V613234 →  713 6441 40	
			 88 mm  818 0207 10	
			 68 mm  840 0274 10	
			 ↔  840 0880 10	
			 right  840 0879 10	
			 left  462 0155 10	
2.5 CDTI G9U 730; (99kW)	04.03-07.06	LUK	G6 ;  PK6.007 PK6.027 PK6.028 GearBOX 462 0202 10	
			 G9U 730;  →C022528;  MANU GearBOX 623 3159 09	
			SAC  624 3945 09	
			 G9U 730;  C022529 →;  MANU  624 3945 33	
			 G9U 730;  C022529 →;  MANU ;  PK6 ;  N° 3##  624 3945 34	
			 G9U 730;  C022529 →;  MANU ;  PK6 ;  N° 0##  415 0146 10	
			 G9U 730;  →4V644188  530 0198 10	
			incl.  531 0548 10	
		INA	 532 0313 20	
			 ; A/C ; OPTION  529 0436 10	
			 ;  ; OPTION  532 0333 10	
			 ; A/C  532 0364 20	
			 ; A/C  534 0181 10	
			 ;   534 0317 10	
			 ;   544 0094 10	
			 A/C  FB 6PK1148	
			 ; A/C 535 0030 10	
			G9U 630 535 0081 10	
			F-238512.XX 544 0094 10	
			# F-560843.XX F-556602.XX F-229643.XX 535 0081 10	
			# G9U 630 544 0094 10	
			# F-238512.XX FB 6PK1148	
			; A/C 544 0094 10	
			; A/C FB 6PK1148	
			; 544 0094 10	



			SCHAEFFLER
--	--	--	-------------------

VAUXHALL

VIVARO A Platform/Chassis (X83)















2.5 CDTI G9U 730; (99kW)	04.03-07.06		; A/C		FB 6PK1795
			;		538 0374 10
			16x  11 mm		420 0063 10
			1x; 		428 0185 10
			1x; 		428 0186 10
			FAG  → 6V699999; 6Y999999; right		821 0490 10
			right;  7V600001; 7Y000001→		821 0822 10
			→ 6V699999; 6Y999999; left		821 0489 10
			left;  7V600001; 7Y000001→		821 0821 10
			; ABS;  → 3V613233  86 mm	 Set	713 6441 20
		; ABS;  → 3V613233  86 mm	 Set	713 6441 30	
		;  3V613234→  88 mm	 Set	713 6442 90	
		 68 mm	 Set	713 6441 40	
				814 0135 10	
				818 0207 10	
				825 0260 10	
				840 0274 10	
		right		840 0880 10	
		left		840 0879 10	
		2.5 CDTI G9U 630; (107kW)	08.06-07.14		→ C022528; MANU SAC
C022529→; MANU					624 3945 09
C022529→; MANU; PK6; N° 3##					624 3945 33
C022529→; MANU; PK6; N° 0##					624 3945 34
→ 4V644188 incl.					415 0146 10
					530 0198 10
				531 0548 10	
				532 0313 20	
; MY 2011; A/C; OPTION				529 0437 10	
; MY 2011; ; OPTION				532 0333 10	
; A/C				532 0364 20	
; MY 2011; A/C				532 0534 10	
; MY 2011; A/C				534 0181 10	
; A/C				534 0317 10	
;				534 0317 10	
; A/C				534 0317 10	
;				534 0317 10	
# F-560843.XX F-556602.XX F-229643.XX				535 0030 10	
A/C				544 0098 10	
; A/C				FB 7PK1113	
;				FB 7PK1795	
; A/C				FB 7PK1835	
; A/C; OPTION				FB 7PK1835	
; ; OPTION				FB 7PK1835	
;				538 0374 10	
16x  11 mm				420 0063 10	
1x; 				428 0185 10	
1x; 				428 0186 10	
FAG  → 6V699999; 6Y999999; right				821 0490 10	
right;  7V600001; 7Y000001→				821 0822 10	
→ 6V699999; 6Y999999; left		821 0489 10			
left;  7V600001; 7Y000001→		821 0821 10			
; ABS;  → 3V613233  86 mm	 Set	713 6441 20			
; ABS;  → 3V613233  86 mm	 Set	713 6441 30			
;  3V613234→  88 mm	 Set	713 6442 90			
 68 mm	 Set	713 6441 40			





























































































			SCHAEFFLER
--	---	--	-------------------

VAUXHALL

VIVARO A Platform/Chassis (X83)

2.5 CDTi G9U 630; (107kW)	08.06-07.14	FAG	 814 0135 10	
			 818 0207 10	
			 825 0260 10	
			 7V621198 7Y721613→;  825 0261 10	
			 right 840 0274 10	
			 left 840 0880 10	
 840 0879 10				















































VIVARO B (X82)

1.6 CDTi R9M 408; (66-85kW)	05.14-	LUK	SAC		624 3930 33
				415 0796 10	
			  ; A/C		529 0246 10
					532 0534 10
					534 0624 10
			 # F-236675.XX F-561464.XX		535 0080 10
		 # F-552305.XX		535 0153 10	
		16x		538 0399 10	
		 12 mm		420 0086 10	
		16x		422 0078 10	
		FAG	 	713 6451 90	
			 818 0207 10		
			 840 0274 10		
			 right 840 0880 10		
 left 840 0879 10					
 840 0879 10					
1.6 CDTi R9M 413; (70kW)	08.16-	LUK	SAC		624 3930 33
				415 0796 10	
			  ; A/C		529 0246 10
					532 0534 10
					534 0624 10
			 # F-236675.XX F-561464.XX		535 0080 10
		 # F-552305.XX		535 0153 10	
		16x		538 0399 10	
		 12 mm		420 0086 10	
		16x		422 0078 10	
		FAG	 	713 6451 90	
			 818 0207 10		
			 840 0274 10		
			 right 840 0880 10		
 left 840 0879 10					
 840 0879 10					
1.6 CDTi R9M 450; (88-103kW)	05.14-	LUK	SAC		624 3930 33
				415 0796 10	
			  ; A/C		529 0247 10
					532 0534 10
					534 0624 10
			 # F-236675.XX F-561464.XX		535 0080 10
		 # F-552305.XX		535 0153 10	
		 ; A/C		FB 7PK1325	
		16x		538 0399 10	
		 12 mm		420 0086 10	
		16x		422 0078 10	
		FAG	 	713 6451 90	
			 818 0207 10		
			 840 0274 10		
 right 840 0880 10					
 left 840 0879 10					
 840 0879 10					
1.6 CDTi R9M 450; (92-107kW)	08.16-	LUK	SAC		624 3930 33
				415 0796 10	
			; A/C		529 0247 10
					532 0534 10
					534 0624 10
			# F-236675.XX F-561464.XX		535 0080 10
		# F-552305.XX		535 0153 10	
		; A/C		FB 7PK1325	
		16x		538 0399 10	
		12 mm		420 0086 10	
		16x		422 0078 10	
		FAG		713 6451 90	
			818 0207 10		
			840 0274 10		
right 840 0880 10					
left 840 0879 10					
840 0879 10					





































































			SCHAEFFLER
--	---	--	-------------------

VAUXHALL

VIVARO B (X82)								
1.6 CDTi R9M 450; (92-107kW)	08.16-		16x  12 mm		420 0086 10			
			16x		422 0078 10			
		FAG				713 6451 90		
				 ↔		818 0207 10		
				 ↔		840 0274 10		
				 right		840 0880 10		
				 left		840 0879 10		
				LUK		SAC		624 3930 33
								415 0796 10
							 ; A/C	
		532 0534 10						
		534 0624 10						
 # F-238675.XX F-561464.XX		535 0080 10						
1.6 CDTi R9M 450; (103kW)	06.14-		 # F-552305.XX		535 0153 10			
			 ; A/C		FB 7PK1325			
					538 0399 10			
			16x  12 mm		420 0086 10			
			16x		422 0078 10			
			FAG			713 6451 90		
		 ↔		818 0207 10				
		 ↔		840 0274 10				
		 right		840 0880 10				
		 left		840 0879 10				

VW

CADDY III Box (2KA, 2KH, 2CA, 2CH)								
1.2 TSi CBZA; (63kW)	09.10-05.15	LUK	G5;  0AH;  ID LSQ	GearBOX	462 0196 10			
					622 3336 00			
			 ; A/C		529 0039 30			
				 ; A/C		532 0632 10		
				 ; A/C		534 0065 10		
				 # F-572716.XX F-240139.XX F-576346.XX		535 0155 10		
				 ; A/C		FB 6PK1432		
				 ;  CBZA CBZB; A/C		FB 6PK1693		
						538 0075 10		
						400 0478 10		
						400 0479 10		
						420 0098 10		
		8x  12 mm	1x; 11.11→		558 0056 10			
					559 0026 30			
					559 0079 10			
					711 0244 10			
				FAG		 ;  1ZF		713 6106 10
						 ;  1ZF		713 6109 90
								713 6108 30
						 right  ; PR. F0A; G5		771 0360 30
						 left  ; G5		771 0016 30
						 left  ;  2K...B...200 001→; G5		771 0567 30
		 right  ; G5				772 0250 30		
		 left  ; PR. F0A; G5				772 0434 30		
		 left  ;  ; G5		772 0445 30				
		 left  ;  2K...B...200 001→; G5		772 0496 30				
					815 0040 30			
					818 0194 10			
					818 0316 10			
					825 0361 10			
	825 0362 10							
	840 0169 10							
	840 1156 10							
	840 1155 10							



			<p>SCHAEFFLER</p>
--	--	--	--------------------------

VW

CADDY III Box (2KA, 2KH, 2CA, 2CH)



































































































<p>1.2 TSI CBZB; (77kW)</p>	<p>09.10-05.15</p>	<p>LUK</p>	<p>G5; 0AH; ID LSQ LSP NNG NNH</p>	<p>GearBOX</p> <p>462 0196 10 622 3336 00 529 0039 30 532 0632 10 534 0065 10 535 0155 10 FB 6PK1432 FB 6PK1693 538 0075 10 400 0478 10 400 0479 10 420 0098 10</p>
		<p>INA</p>	<p>A/C A/C A/C F-572716.XX F-240139.XX F-576346.XX A/C CBZA CBZB; A/C</p>	<p>529 0039 30 532 0632 10 534 0065 10 535 0155 10 FB 6PK1432 FB 6PK1693 538 0075 10 400 0478 10 400 0479 10</p>
		<p>FAG</p>	<p>12F 136 mm 12F right; PR. F0A; G5 100 mm left; G5 97,95 mm left; 2K...B...200 001→; G5 right; G5 left; PR. F0A; G5 left; G5 left; 2K...B...200 001→; G5 right left right left</p>	<p>713 6106 10 713 6109 90 713 6108 30 771 0360 30 771 0016 30 771 0567 30 772 0250 30 772 0434 30 772 0445 30 772 0496 30 815 0040 30 818 0194 10 818 0316 10 825 0361 10 825 0362 10 840 0169 10 840 1156 10 840 1155 10</p>
<p>1.4 BCA; (55kW)</p>	<p>03.04-05.06</p>	<p>LUK</p>	<p>G5; 0AH; ID GXZ MQ 250 MQ 200</p>	<p>GearBOX</p> <p>462 0195 10 622 3336 00 512 0010 10 512 0012 10 530 0089 10 530 0089 31 531 0317 10 531 0339 10 532 0167 10 532 0185 10 534 0123 20 FB 6PK1100 FB 6PK737 538 0026 10 420 0098 10</p>
		<p>INA</p>	<p>A/C A/C A/C</p>	<p>530 0089 10 530 0089 31 531 0317 10 531 0339 10 532 0167 10 532 0185 10 534 0123 20 FB 6PK1100 FB 6PK737 538 0026 10</p>
		<p>FAG</p>	<p>16x 12 mm 16x 1x; 1x; right right left left →2K-5-150000 136 mm 2K-6-000001→; 1ZF,1ZM 136 mm 2K-6-000001→; 1ZF,1ZM Set Set Set right; G5 100 mm</p>	<p>422 0012 10 428 0172 10 428 0169 10 821 0564 10 821 0768 10 821 0563 10 821 0767 10 713 6106 10 713 6106 10 713 6109 90 713 6108 30 771 0360 30</p>



			SCHAEFFLER
--	---	--	-------------------

VW

CADDY III Box (2KA, 2KH, 2CA, 2CH)











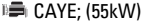















































































































































1.4 BCA; (55kW)	03.04-05.06	FAG	 ; G5	 SET	772 0250 30			
			 REP	815 0040 30				
				818 0194 10				
				818 0316 10				
			 right	825 0361 10				
			 left	825 0362 10				
				840 0169 10				
			 right	840 1156 10				
			 left	840 1155 10				
			1.4 BUD; (59kW)	05.06-08.10	LUK	G5 ;  0AH ;  JJW LBW GXZ	GearBOX	462 0195 10
						G5 ;  0AH ;  MBQ	GearBOX	462 0196 10
					 MQ 250		512 0010 10	
					 MQ 200		512 0012 10	
							530 0538 10	
	530 0538 30							
	531 0317 10							
	531 0339 10							
	532 0167 10							
	534 0123 20							
	FB 6PK1100							
	FB 6PK737							
	538 0026 10							
	420 0098 10							
16x  12 mm		422 0012 10						
16x		428 0172 10						
1x; 		428 0169 10						
1x;  MY 2008		428 0173 10						
1x;  MY 2009		428 0173 10						
FAG	 right; →06.10		821 0564 10					
	 right; →06.10		821 0768 10					
	 left; →06.10		821 0563 10					
	 left; →06.10		821 0767 10					
	 ;  →2K-5-150000	 Set	713 6106 10					
	 ;  2K-6-000001→;  1ZF,1ZM	 Set	713 6106 10					
	 ;  2K-6-000001→;  1ZF,1ZM	 Set	713 6109 90					
		 Set	713 6108 30					
	 ; G5		771 0360 30					
	 ; G5		772 0250 30					
			815 0040 30					
		818 0194 10						
		818 0316 10						
	 right	825 0361 10						
 left	825 0362 10							
	840 0169 10							
 right	840 1156 10							
 left	840 1155 10							
1.6 TDI CAYE; (55kW)	08.10-05.15	LUK	G5 ;  0A4 ;  MHZ	GearBOX	462 0333 10			
					623 3534 00			
				530 0550 10				
				530 0550 32				
				531 0825 10				
				532 0161 10				
				532 0582 10				
				532 0623 10				
				534 0164 10				
				535 0012 10				
				FB 6PK1070				
				538 0060 10				
			420 0222 10					
		16x;  CAYE		422 0102 10				
 12 mm		422 0102 10						
16x;  CAYE		422 0102 10						
FAG	 ;  1ZF	 Set	713 6106 10					
	 ;  1ZF	 Set	713 6109 90					



			SCHAEFFLER
--	--	--	-------------------

VW

CADDY III Box (2KA, 2KH, 2CA, 2CH)























































































































<p>1.6 TDI  CAYE; (55kW)</p>	<p>08.10-05.15</p>	<p>FAG</p>	  left  ; G5	 Set	713 6108 30
			  right  ; 03.14→; 3.002; G5		771 0567 30
			  right  ; 03.14→; 2.682; G5		771 0016 30
			  right  ; 03.14→; 2.682; G5		771 0360 30
			  left  ; G5		772 0496 30
			  left  ; 03.14→; G5		772 0250 30
			  left  ; →03.14; PR. FOA; G5		772 0434 30
			  right  ; 03.14→; 3.002; PR. FOA OE2; G5		772 0445 30
			  left  ; →03.14; G5		772 0445 30
			  left  ; 03.14→;  ; G5		772 0445 30
					815 0040 30
					818 0194 10
					818 0316 10
			 right		825 0361 10
			 left		825 0362 10
					840 0169 10
			 right		840 1156 10
			 left		840 1155 10
<p>1.6  BGU; BSE; BSF; (75kW)</p>	<p>04.04-05.15</p>	<p>LUK</p>	G5 ;  0AH ;  ID JJT LBR FZT	GearBOX	462 0195 10
			G5 ;  0AH ;  ID KHS Lbv MBR	GearBOX	462 0196 10
					622 3336 00
			 MQ 250		512 0010 10
			 MQ 200		512 0012 10
					530 0171 10
				530 0171 31	
				531 0203 20	
		 ;  A/C		529 0429 10	
				533 0076 30	
		 # F-553470.XX F-227628.XX		535 0012 10	
		 ; für Fahrzeuge mit hydraulischer Servolenkung A/C		FB 6DPK1195	
		 ; für Fahrzeuge mit hydraulischer Servolenkung A/C		FB 6PK1125	
		 ;  A/C		FB 6PK900	
				538 0088 10	
				428 0050 30	
		<p>FAG</p>	 right; →06.10		821 0564 10
			 right; →06.10		821 0768 10
			 left; →06.10		821 0563 10
			 left; →06.10		821 0767 10
			 ;  →2K-5-150000		713 6106 10
			  2K-6-000001→;  1ZF,1ZM		713 6106 10
			  2K-6-000001→;  1ZF,1ZM		713 6109 90
					713 6108 30
 left  ; 3.002; G5			771 0016 30		
  ; 97,95 mm			771 0360 30		
  ; G5			771 0360 30		
  ; 100 mm			771 0360 30		
 left  ; G5 ; 3.002; 09.07→			772 0434 30		
  ; G5			772 0250 30		
			815 0040 30		
			818 0194 10		
			818 0316 10		
 right			825 0361 10		
 left		825 0362 10			
		840 0169 10			
right		840 1156 10			
left		840 1155 10			
<p>1.6 TDI  CAYD; (75kW)</p>	<p>08.10-05.15</p>	<p>LUK</p>	G5 ;  0A4 ;  ID MHZ MLS	GearBOX	462 0333 10
			→05.11;  DSG		602 0002 00
			06.11→;  DSG		602 0007 00
					623 3534 00
			 DSG		415 0626 09
			incl. 		512 0010 10

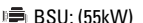

			SCHAEFFLER
--	---	--	-------------------

VW

CADDY III Box (2KA, 2KH, 2CA, 2CH)





























































































<p>1.6 TDI  (75kW)</p>	<p>08.10-05.15</p>	<p></p>			530 0550 10	
					530 0550 32	
					531 0825 10	
					532 0161 10	
					532 0582 10	
					532 0623 10	
					534 0164 10	
					535 0012 10	
					FB 6PK1070	
					538 0060 10	
				16x  12 mm		420 0222 10
				16x		422 0102 10
				FAG  ;  1ZF  136 mm	 Set	713 6106 10
				 ;  1ZF	 Set	713 6109 90
					 Set	713 6108 30
				 right =  ; G5  97,95 mm		771 0016 30
				 left =  ; G7		771 0567 30
				 left =  ; G5		
				 right =  ; G5		772 0434 30
				 left =  ; G7		772 0496 30
				 left =  ; G5		
				 ;  G5 G7		772 0445 30
						815 0040 30
						818 0194 10
						818 0316 10
	 right		825 0361 10			
	 left		825 0362 10			
			840 0169 10			
	 right		840 1156 10			
	 left		840 1155 10			
<p>1.6 BiFuel  (75kW)</p>	<p>05.11-05.15</p>	<p></p>	G5 ;  0AH ;  ID LBV MBR	GearBOX	462 0196 10	
					530 0171 10	
					530 0171 31	
					531 0203 20	
					529 0429 10	
					533 0076 30	
					535 0012 10	
					FB 6PK900	
					538 0088 10	
				16x  12 mm		420 0224 10
				16x		422 0007 10
						428 0161 10
				FAG  ;  1ZF  136 mm	 Set	713 6106 10
				 ;  1ZF	 Set	713 6109 90
					 Set	713 6108 30
				 left =  ; G5  97,95 mm		771 0016 30
				 ; G5  100 mm		771 0360 30
				 left =  ; G5		772 0434 30
				 ; G5		772 0250 30
						815 0040 30
						818 0194 10
				 right		825 0361 10
				 left		825 0362 10
						840 0169 10
				 right		840 1156 10
	 left		840 1155 10			
<p>1.9 TDI  (55kW)</p>	<p>09.05-08.10</p>	<p></p>	 MQ 250		623 3239 00	
			 MQ 200		512 0012 10	
		<p></p>			530 0201 10	
					530 0201 33	



			<p>SCHAEFFLER</p>
--	--	--	--------------------------

VW

CADDY III Box (2KA, 2KH, 2CA, 2CH)

































































































































<p>1.9 TDI BSU; (55kW)</p>	<p>09.05-08.10</p>	<p></p>	<p> 531 0565 30  532 0349 10  534 0151 10  535 0012 10  544 0083 10  544 0083 20  FB 6DPK1215  FB 6PK1050  FB 6PK1138  FB 6PK948  538 0054 10  428 0039 30  559 0068 10 FAG  right; →06.10  821 0564 10  right; →06.10  821 0768 10  left; →06.10  821 0563 10  left; →06.10  821 0767 10  →2K-5-150000  Set 713 6106 10  136 mm  Set 713 6106 10  →2K-6-000001→; 1ZF,1ZM  Set 713 6106 10  136 mm  Set 713 6109 90  →2K-6-000001→; 1ZF,1ZM  Set 713 6108 30  →05.08; G5  771 0016 30  97,95 mm  771 0578 30  →AUTOM G6  771 0578 30  80 mm  772 0434 30  →05.08; G5  SET 772 0445 30  →G5  SET 772 0445 30  →G5  REP 815 0040 30   818 0194 10   818 0316 10  right  825 0361 10  left  825 0362 10   840 0169 10  right  840 1156 10  left  840 1155 10</p>	
<p>1.9 TDI BJB; BLS; (77kW)</p>	<p>04.04-08.10</p>	<p></p>	<p>GearBOX G5; →0A4; →ID LFZ  462 0333 10 incl. →; incl. →; SAC  600 0016 00  LuK  623 3094 21 SAC; incl. →  Sachs  623 3209 00 SAC  415 0250 10 + 623 3094 00/21  415 0723 09 →04.10; →BLS; →DSG  411 0133 10 →MANU  512 0010 10 →BLS; 2CT  530 0201 10   530 0201 33  531 0565 30  532 0349 10  534 0059 10  534 0151 10  535 0012 10  544 0083 10  544 0083 20  FB 6DPK1215  FB 6PK1050  FB 6PK1138  FB 6PK948  538 0054 10  428 0039 30  428 0042 30  559 0068 10 FAG  right; →06.10  821 0564 10  right; →06.10  821 0768 10</p>	



			SCHAEFFLER
--	---	--	-------------------

VW

CADDY III Box (2KA, 2KH, 2CA, 2CH)

1.9 TDI  BJB; BLS; (77kW)	04.04-08.10	FAG	 left; →06.10	 821 0563 10
			 left; →06.10	 821 0767 10
			 ;  →2K-5-150000	 Set 713 6106 10
			 136 mm	
			 ;  2K-6-000001→;  1ZF,1ZM	 Set 713 6106 10
			 136 mm	
			 ;  2K-6-000001→;  1ZF,1ZM	 Set 713 6109 90
				 Set 713 6108 30
			 ;  BJB; G5	 771 0016 30
			 ;  BLS; G5  AUTOM G6	
			 97,95 mm	
			 ;  AUTOM G6; →01.09	 771 0578 30
			 80 mm	
			 ; →05.08; G5	 SET 772 0434 30
			 ;  BLS;  AUTOM G6	
			 ; →01.09;  AUTOM G6	 SET 772 0440 30
			 ; G5	 SET 772 0445 30
			 ; G5	
				 REP 815 0040 30
				 818 0194 10
	 818 0316 10			
 right	 825 0361 10			
 left	 825 0362 10			
	 840 0169 10			
 right	 840 1156 10			
 left	 840 1155 10			
1.9 TDI 4motion  BLS; (77kW)	11.08-08.10	LUK	→11.09	 600 0017 00
			incl.  ; incl.  ; SAC	
			→11.09;  LuK	 624 3180 34
			SAC	
			→11.09;  Sachs	 624 3230 34
			SAC	
			12.09→;  510 0176 10	 624 3731 09
			SAC	
			12.09→	 624 3731 33
			SAC	
			→11.09;  624 3180 09/34	 415 0431 10
				 411 0133 10
				 530 0201 10
				 530 0201 33
				 531 0565 30
			 532 0349 10	
			 534 0151 10	
		 # F-553470.XX F-227628.XX	 535 0012 10	
			 544 0083 10	
			 544 0083 20	
		 ; A/C für Fahrzeuge mit hydraulischer Servolenkung	 FB 6DPK1215	
		 ; A/C 	 FB 6PK1050	
		 ; A/C 	 FB 6PK1138	
		 ; A/C 	 FB 6PK948	
			 428 0039 30	
		1x	 559 0068 10	
		FAG	 right; →06.10	 821 0564 10
			 right; →06.10	 821 0768 10
			 left; →06.10	 821 0563 10
			 left; →06.10	 821 0767 10
	 Set 713 6106 10			
 136 mm				
 ; G6	 SET 772 0445 30			
	 REP 815 0040 30			
	 818 0194 10			
	 818 0316 10			
 right	 825 0361 10			
 left	 825 0362 10			
	 840 0169 10			
 right	 840 1156 10			
 left	 840 1155 10			
2.0 SDI  BDJ; BST; (51kW)	03.04-08.10	LUK	G5 ;  0AH ;  ID FZU HFN JJS KBQ KHH LBT LBU	GearBOX 462 0195 10
			G5 ;  0AH ;  ID MBS MBU MHR	GearBOX 462 0196 10















































































			SCHAEFFLER
--	---	--	-------------------

VW

CADDY III Box (2KA, 2KH, 2CA, 2CH)























2.0 SDI
BDJ; BST; (51kW)

03.04-08.10

		MQ 250		622 3336 00
		MQ 200		512 0010 10
				512 0012 10
				530 0201 10
				530 0201 33
				531 0565 30
				532 0349 10
		→2K-5-150 000		534 0059 10
		→2K-6-000 001→		534 0151 10
		F-553470.XX F-227628.XX		535 0012 10
				544 0083 10
				544 0083 20
		A/C für Fahrzeuge mit hydraulischer Servolenkung		FB 6DPK1215
		A/C		FB 6PK1050
		A/C für Fahrzeuge mit hydraulischer Servolenkung		FB 6PK1138
		A/C		FB 6PK948
				538 0054 10
	8x			420 0209 10
		35 mm		
	1x			559 0068 10
		right; →06.10		821 0564 10
		right; →06.10		821 0768 10
		left; →06.10		821 0563 10
		left; →06.10		821 0767 10
		→2K-5-150000		713 6106 10
		136 mm		713 6106 10
		2K-6-000001→; 1ZF,1ZM		713 6106 10
		136 mm		713 6109 90
		2K-6-000001→; 1ZF,1ZM		713 6109 90
				713 6108 30
		left; →; G5		771 0016 30
		97,95 mm		
		→; G5		771 0360 30
		100 mm		
		left; →; G5; →		772 0434 30
		→; G5		772 0250 30
				815 0040 30
				818 0194 10
				818 0316 10
		right		825 0361 10
		left		825 0362 10
				840 0169 10
		right		840 1156 10
		left		840 1155 10

2.0 TDI
CFHE; (62kW)

11.10-05.15











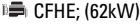



































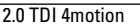



































































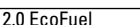











		→05.11; START/STOP incl. ○; incl.  ; SAC		600 0017 00
		→05.11; START/STOP incl. ○; incl. 		600 0295 00
		06.11→; START/STOP incl. ○; incl. 		600 0299 00
		→05.11; ○LuK SAC		624 3180 34
		06.11→; ○LuK SAC		624 3553 33
		→05.11; ○Sachs ; + 510 0176 10		624 3731 09
		06.11→; ○Sachs SAC		624 3731 33
		→05.11; START/STOP ; + 624 3180 09/34		415 0431 10
		06.11→; START/STOP ; + 624 3553 09/33		415 0583 10
		→05.11; START/STOP ; + 624 3180 09/34		415 0583 10
		06.11→; START/STOP ; + 624 3553 09/33		411 0133 10
				530 0550 10
				530 0550 32
				531 0825 10
				532 0161 10
				532 0582 10
				532 0623 10



			SCHAEFFLER
--	---	--	-------------------

VW

CADDY III Box (2KA, 2KH, 2CA, 2CH)

2.0 TDI  CFHE; (62kW)	11.10-05.15		 534 0164 10	 534 0164 10		
			 # F-553470.XX F-227628.XX	 535 0012 10		
			 ; A/C	 FB 6PK1070		
			 16x	 538 0060 10		
			 12 mm	 420 0222 10		
			 16x	 422 0102 10		
			FAG	 ;  1ZF	 Set 713 6106 10	
				 136 mm	 Set 713 6109 90	
				 ;  1ZF	 Set 713 6108 30	
					 REP 815 0040 30	
				 818 0194 10		
		 right		 825 0361 10		
		 left		 825 0362 10		
				 840 0169 10		
		 right		 840 1156 10		
		 left		 840 1155 10		
		2.0 TDI 4motion  CFHE; (62kW)	12.10-05.15		 →05.11; START/STOP	 600 0017 00
					incl.  ; incl.  ; SAC	 600 0295 00
					 →05.11; START/STOP	 600 0299 00
					incl.  ; incl. 	 624 3180 34
06.11→; START/STOP	 624 3553 33					
incl.  ; incl.  ; SAC	 624 3731 09					
→05.11;  LuK	 624 3731 33					
SAC	 415 0431 10					
06.11→;  LuK	 415 0583 10					
SAC	 411 0133 10					
→05.11;  Sachs ;  510 0176 10	 530 0550 10					
06.11→;  Sachs	 530 0550 32					
SAC	 531 0825 10					
 Sachs	 532 0161 10					
SAC	 532 0582 10					
→05.11; START/STOP ;  624 3180 09/34	 532 0623 10					
06.11→; START/STOP ;  624 3553 09/33	 534 0164 10					
→05.11; START/STOP ;  624 3180 09/34	 534 0164 10					
06.11→; START/STOP ;  624 3553 09/33	 535 0012 10					
	 ; A/C	 FB 6PK1070				
	 16x	 538 0060 10				
	 12 mm	 420 0222 10				
	 16x	 422 0102 10				
	FAG	 ; 	 Set 713 6106 10			
		 136 mm	 SET 772 0445 30			
		 ;  G6	 REP 815 0040 30			
			 818 0194 10			
		 right	 825 0361 10			
		 left	 825 0362 10			
		 840 0169 10				
 right		 840 1156 10				
 left		 840 1155 10				
2.0 EcoFuel  BSX; (80kW)		04.06-05.15		 G5 ;  0AH ;  ID GUG JJV KLK LBS	 GearBOX 462 0195 10	
	 G5 ;  0AH ;  ID LBP LJL MBT			 GearBOX 462 0196 10		
				 622 3336 00		
	 MQ 250		 512 0010 10			
			 512 0012 10			
				 530 0171 10		
		 530 0171 30				
		 531 0203 20				



			SCHAEFFLER
--	--	--	-------------------













































































VW

CADDY III Box (2KA, 2KH, 2CA, 2CH)

2.0 EcoFuel
BSX; (80kW)

04.06-05.15











































 ;  A/C		529 0429 10
		533 0076 30
Part # F-553470.XX F-227628.XX		535 0012 10
		544 0003 10
 ; für Fahrzeuge mit hydraulischer Servolenkung A/C		FB 6DPK1195
 ; für Fahrzeuge mit hydraulischer Servolenkung A/C		FB 6PK1125
 ;  A/C		FB 6PK900
		538 0038 10
16x		420 0043 10
 35 mm		
FAG  right; →06.10		821 0564 10
 right; →06.10		821 0768 10
 left; →06.10		821 0563 10
 left; →06.10		821 0767 10
 ;  →2K-5-150000	 Set	713 6106 10
 136 mm		
 ;  2K-6-000001→;  1ZF,1ZM	 Set	713 6106 10
 136 mm		
 ;  2K-6-000001→;  1ZF,1ZM	 Set	713 6109 90
	 Set	713 6108 30
 left  ; 07.09→; G5		771 0016 30
 97,95 mm		
 left  ; →06.09; G5		771 0344 30
 89,9 mm		
 ; G5		771 0360 30
 100 mm		
 left  ; 07.09→; 3.002; G5	 SET	772 0434 30
 left  ; G5 ; →06.09	 SET	772 0491 30
 left  ; G5 ; 07.09→; PR. 0E1; 2.682		
 ; G5	 SET	772 0250 30
	 REP	815 0040 30
		818 0194 10
		818 0316 10
 right		825 0361 10
 left		825 0362 10
		840 0169 10
 right		840 1156 10
 left		840 1155 10

2.0 TDI
CLCA; (81kW)

08.10-05.15









































































































































G5 ;  0A4 ;  ID MHZ	GearBOX	462 0333 10
incl.  ; incl.  ; SAC		600 0199 00
 LuK		623 3094 21
SAC; incl. 		
 Sachs		623 3542 00
SAC		
+ 623 3094 00/21		415 0574 10
		411 0133 10
		512 0010 10
		530 0550 10
		530 0550 32
		531 0825 10
		532 0161 10
		532 0582 10
		532 0623 10
		534 0164 10
Part # F-553470.XX F-227628.XX		535 0012 10
 ; A/C		FB 6PK1070
		538 0060 10
16x		420 0222 10
 12 mm		
16x		422 0102 10
FAG  ;  1ZF	 Set	713 6106 10
 136 mm		
 ;  1ZF	 Set	713 6109 90
	 Set	713 6108 30
 right  ; G5		771 0016 30
97,95 mm		
right ; G5	SET	772 0434 30
; G5	SET	772 0445 30



			SCHAEFFLER
--	---	--	-------------------

VW

CADDY III Box (2KA, 2KH, 2CA, 2CH)











































2.0 TDI CLCA; (81kW)	08.10-05.15	FAG	  815 0040 30
			 818 0194 10
			 right  825 0361 10
			 left  825 0362 10
			 840 0169 10
			 right  840 1156 10
			 left  840 1155 10
			 →05.11; START/STOP  600 0017 00 incl.   SAC
			 →05.11; START/STOP  600 0295 00 incl.  
			 06.11→; START/STOP  600 0299 00 incl.   SAC
			 →05.11;  LuK  624 3180 34 SAC
			 06.11→;  LuK  624 3553 33 SAC
			 →05.11;  Sachs;  510 0176 10  624 3731 09
			 06.11→;  Sachs  624 3731 33 SAC
			 →05.11; START/STOP ;  624 3180 09/34  415 0431 10
 06.11→; START/STOP ;  624 3553 09/33  415 0583 10			
 →05.11; START/STOP ;  624 3180 09/34  415 0583 10			
 06.11→; START/STOP ;  624 3553 09/33  411 0133 10			
  530 0550 10			
  530 0550 32			
  531 0825 10			
  532 0161 10			
  532 0582 10			
  532 0623 10			
  534 0164 10			
  # F-553470.XX F-227628.XX  535 0012 10			
  ; A/C  FB 6PK1070			
 16x  420 0222 10  12 mm			
 16x  422 0102 10			
   713 6106 10  136 mm			
  ; →10.13; G5  771 0016 30			
 right  ; →10.13→; G5  772 0434 30			
  97,95 mm  772 0445 30			
  ; PR. FOA; →10.13; G5  815 0040 30			
 right  ; PR. FOA; 10.13→; G5  818 0194 10			
  ; →10.13; G6  818 0316 10			
 right  ; →10.13→; G6  825 0361 10			
   825 0362 10			
 right  840 0169 10			
 right  840 1156 10			
 left  840 1155 10			
 incl.   SAC  600 0017 00			
 LuK  624 3180 34 SAC			
 Sachs  624 3230 34 SAC			
  624 3180 09/34  415 0431 10			
  411 0133 10			
  530 0201 10			
  530 0201 32			
  531 0565 30			
  532 0349 10			
  # F-553470.XX F-227628.XX  534 0151 10			
  535 0012 10			



			SCHAEFFLER
--	--	--	-------------------

VW

CADDY III Box (2KA, 2KH, 2CA, 2CH)











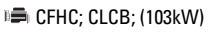























































2.0 TDI BMM; (103kW)	09.07-08.10		 544 0083 10	
			 544 0083 20	
2.0 TDI 16V CFHC; CLCB; (103kW)	11.10-05.15		→05.11; START/STOP incl.  ; incl.  ; SAC	
			→05.11; START/STOP incl.  ; incl. 	
			06.11→; START/STOP incl.  ; incl.  ; SAC	
			→05.11;  LuK SAC	
			06.11→;  LuK SAC	
			→05.11;  Sachs ; + 510 0176 10	
			06.11→;  Sachs SAC	
			 Sachs SAC	
			→05.11; START/STOP ; + 624 3180 09/34	
			06.11→; START/STOP ; + 624 3553 09/33	
			→05.11; START/STOP ; + 624 3180 09/34	
			06.11→; START/STOP ; + 624 3553 09/33	
			 DSG	
			 MANU 2CT	
				 KIT 530 0550 10
				 KIT+ 530 0550 32
				 531 0825 10
				 532 0161 10
				 532 0582 10
				 532 0623 10
				 534 0164 10
				 # F-553470.XX F-227628.XX
				 535 0012 10
				 538 0060 10
				 420 0222 10
				16x  12 mm
				16x  422 0102 10
				  713 6106 10
  713 6109 90				
  713 6108 30				
  772 0440 30				
  815 0040 30				



			SCHAEFFLER
--	---	--	-------------------

VW

CADDY III Box (2KA, 2KH, 2CA, 2CH)

































2.0 TDI 16V  (103kW)	11.10-05.15	FAG	 818 0194 10				
			 818 0316 10				
			 right 825 0361 10				
			 left 825 0362 10				
			 840 0169 10				
			 right 840 1156 10				
			 left 840 1155 10				
			 →05.11; START/STOP incl.  ; SAC 600 0017 00				
			 →05.11; START/STOP incl.  ; SAC 600 0295 00				
			 06.11→; START/STOP incl.  ; SAC 600 0299 00				
			 →05.11;  LuK SAC 624 3180 34				
			 06.11→;  LuK SAC 624 3553 33				
			 →05.11;  Sachs; + 510 0176 10 624 3731 09				
			 06.11→;  Sachs SAC 624 3731 33				
			 →05.11; START/STOP ; + 624 3180 09/34 415 0431 10				
 06.11→; START/STOP ; + 624 3553 09/33 415 0583 10							
 →05.11; START/STOP ; + 624 3180 09/34 415 0744 09							
 06.11→; START/STOP ; + 624 3553 09/33 411 0133 10							
 DSG 415 0744 09							
 MANU 411 0133 10							
 2CT							
	11.10-05.15	FAG	 530 0550 10				
			 530 0550 32				
			 531 0825 10				
			 532 0161 10				
			 532 0582 10				
			 532 0623 10				
			 534 0164 10				
			 # F-553470.XX F-227628.XX 535 0012 10				
			 FB 6PK1070				
			 538 0060 10				
			 16x 420 0222 10				
			 12 mm				
			 16x 422 0102 10				
			 Set 713 6106 10				
			FAG	11.10-05.15	FAG	 136 mm 771 0567 30	
 →09.13; G6 772 0445 30							
 →09.13; G6 SET 772 0496 30							
 right →; 10.13→; G6 REP 815 0040 30							
 →09.13; G6 818 0194 10							
 right 825 0361 10							
 left 825 0362 10							
 840 0169 10							
 right 840 1156 10							
 left 840 1155 10							
 DSG 415 0744 09							
 2CT 411 0133 10							
	05.12-05.15	LUK				 530 0550 10	
						 530 0550 32	
						 531 0825 10	
			 532 0161 10				
			 532 0582 10				
			 532 0623 10				
			 534 0164 10				
			 # F-553470.XX F-227628.XX 535 0012 10				
			 A/C FB 6PK1070				
			538 0060 10				
			16x 420 0222 10				
			12 mm				
			16x 422 0102 10				
			LUK	05.12-05.15	LUK	DSG 415 0744 09	
						2CT 411 0133 10	
	05.12-05.15	LUK				530 0550 10	
						530 0550 32	
						531 0825 10	
						532 0161 10	
						532 0582 10	
						532 0623 10	
						534 0164 10	
						# F-553470.XX F-227628.XX 535 0012 10	
						A/C FB 6PK1070	
						538 0060 10	
						16x 420 0222 10	
						12 mm	
						16x 422 0102 10	































































































			SCHAEFFLER
--	---	--	-------------------

VW

CADDY III Box (2KA, 2KH, 2CA, 2CH)

2.0 TDI CFJA; (125kW)	05.12-05.15	FAG	 ;  1ZF	 Set	713 6106 10
			 136 mm		
			 ;  1ZF	 Set	713 6109 90
				 Set	713 6108 30
			 ;  ; G6		771 0567 30
			 ;  2K...B...200001→; G6	 SET	772 0440 30
			 ;  ; G6	 SET	772 0496 30
				 REP	815 0040 30
					818 0194 10
			 right		825 0361 10
			 left		825 0362 10
					840 0169 10
			 right		840 1156 10
 left		840 1155 10			

CADDY IV (SAA, SAB, SAH, SAJ)











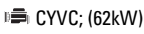









































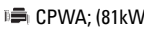











































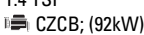





























1.0 TSI CHZG; (75kW)	11.15-				530 0592 10
					531 0882 10
					532 0753 10
			 ; A/C		529 0159 10
			 # 1000847 1010046 1000358 920046		535 0279 10
			 ; A/C		FB 6PK745
			12x		420 0254 10
			 12 mm		
			12x		422 0236 10
			1x		711 0294 10
			FAG	 ;  1ZA, 1ZE	 Set
		 136 mm			
		 ;  0E1, 0E2		 Set	713 6108 30
					814 0076 10
					818 0194 10
		 right			825 0361 10
		 right;  ; PR. IM0			825 0372 10
		 left			825 0362 10
		 left;  ; PR. IM0			825 0371 10
					840 0169 10
		 right			840 1156 10
		 left			840 1155 10
		1.0 TSI CHZG; DKRE; (75kW)	11.15-		
					531 0882 10
					532 0753 10
 ; A/C					529 0159 10
 # 1000847 1010046 1000358 920046					535 0279 10
 ; A/C					FB 6PK745
12x					420 0254 10
 12 mm					
12x					422 0236 10
1x					711 0294 10
FAG	 ;  1ZA,1ZE				 Set
	 136 mm				
	 ;  0E1,0E2			 Set	713 6108 30
					814 0076 10
					818 0194 10
	 right				825 0361 10
	 right;  ; PR. IM0				825 0372 10
	 left				825 0362 10
	 left;  ; PR. IM0				825 0371 10
					840 0169 10
	 right				840 1156 10
	 left				840 1155 10
1.2 TSI CYVC; (62kW)	06.15-				
					530 0592 10
					531 0882 10
					532 0753 10
		 ; A/C			529 0159 10
			 # 1000847 1010046 1000358 920046		535 0279 10
			 ; A/C		FB 6PK745
					538 0363 10



			SCHAEFFLER
--	--	--	-------------------

VW

CADDY IV (SAA, SAB, SAH, SAJ)



























































































































1.2 TSI  (62kW)	06.15-		16x		420 0254 10		
			 12 mm				
			16x		422 0236 10		
			1x		711 0244 10		
			FAG		 ;  1ZA, 1ZE		713 6106 10
					 136 mm		
					 ;  1ZA, 1ZE		713 6106 10
					 136 mm		
					 ;  OE1, OE2		713 6108 30
					 ;  OE1, OE2		713 6108 30
					 ;  G5		771 0360 30
					 100 mm		
					 ;  G5		772 0250 30
							814 0076 10
							818 0194 10
					right		825 0361 10
					right;  ; PR. IMO		825 0372 10
					left		825 0362 10
			left;  ; PR. IMO		825 0371 10		
					840 0169 10		
right		840 1156 10					
left		840 1155 10					
1.4 TGI CNG  (81kW)	06.15-		SAC		623 3734 00		
					530 0592 10		
					531 0882 10		
					532 0753 10		
			 ; A/C		529 0159 10		
			# 1000847 1010046 1000358 920046		535 0279 10		
			 ; A/C		FB 6PK745		
			16x		420 0254 10		
			 12 mm				
			16x		422 0236 10		
			1x		711 0294 10		
			FAG		 ;  1ZA, 1ZE		713 6106 10
					 136 mm		
					 ;  1ZA, 1ZE		713 6106 10
					 136 mm		
					 ;  OE1, OE2		713 6108 30
					 ;  OE1, OE2		713 6108 30
							814 0076 10
							818 0194 10
					right		825 0361 10
right;  ; PR. IMO		825 0372 10					
left		825 0362 10					
left;  ; PR. IMO		825 0371 10					
		840 0169 10					
right		840 1156 10					
left		840 1155 10					
1.4 TSI  (92kW)	05.15-		  ;  G6		755477		
			LUK	 DSG		602 0006 00	
				SAC		623 3734 00	
			 DSG		415 0768 09		
			2CT ; 		411 0007 10		
					530 0592 10		
					531 0882 10		
					532 0753 10		
			 ; A/C		529 0159 10		
			# 1000847 1010046 1000358 920046		535 0279 10		
			 ; A/C		FB 6PK745		
					538 0363 10		
			FAG		 ;  1ZA, 1ZE		713 6106 10
					 136 mm		
					 ;  1ZA, 1ZE		713 6106 10
					 136 mm		
					 ;  OE1, OE2		713 6108 30
					 ;  OE, OE2		713 6108 30
			 left  ; G6		771 0567 30		



			SCHAEFFLER
--	---	--	-------------------

VW

CADDY IV (SAA, SAB, SAH, SAJ)

























































































1.4 TSI CZCB; (92kW)	05.15-	FAG	left  ; G6		771 0567 30
			 ; G7		
			left  ; G6		772 0496 30
			 ; G7		
			left  ; G6		772 0496 30
					814 0076 10
					818 0194 10
			right		825 0361 10
			right;  ; PR. IM0		825 0372 10
			left		825 0362 10
			left;  ; PR. IM0		825 0371 10
					840 0169 10
			right		840 1156 10
			left		840 1155 10
1.6 TDI CAYE; (55kW)	05.15-11.17	LUK	G5 ;  0A4 ;  ID QXY RTA	GearBOX	462 0333 10
					623 3534 00
					530 0550 10
					530 0550 32
					531 0825 10
					532 0161 10
					532 0582 10
					532 0623 10
					534 0164 10
					535 0012 10
		 # F-553470.XX F-227628.XX		FB 6PK1070	
		 ; A/C		538 0060 10	
		FAG	 ;  1ZA,1ZE		713 6106 10
			 136 mm		
			 ;  0E1,0E2		713 6108 30
			left  ; G5		771 0567 30
			 ; 2.682; G5		771 0360 30
			 100 mm		
			left  ; G5		772 0496 30
			 ; 2.682; G5		772 0250 30
			814 0076 10		
			818 0194 10		
right		825 0361 10			
right;  ; PR. IM0		825 0372 10			
left		825 0362 10			
left;  ; PR. IM0		825 0371 10			
		840 0169 10			
right		840 1156 10			
left		840 1155 10			
1.6 TDI CAYD; (75kW)	05.15-	LUK	G5 ;  0A4 ;  ID QXY QYA RTC RTA	GearBOX	462 0333 10
			 DSG		602 0007 00
			START/STOP		623 3534 00
			START/STOP		623 3548 00
			 DSG		415 0626 09
		incl. 			
					530 0550 10
					530 0550 32
					531 0825 10
					532 0161 10
			532 0582 10		
		532 0623 10			
		534 0164 10			
 # F-553470.XX F-227628.XX		535 0012 10			
 ; A/C		FB 6PK1070			
		538 0060 10			
16x		420 0222 10			
 12 mm					
16x		422 0102 10			
FAG	 ;  1ZA,1ZE		713 6106 10		
	 136 mm				
	 ;  0E1,0E2		713 6108 30		
	left  ; G5 G7		771 0567 30		
	left  ; G5		772 0496 30		
left  ; G7					
		814 0076 10			



			SCHAEFFLER
--	---	--	-------------------

VW

CADDY IV (SAA, SAB, SAH, SAJ)





































































1.6 TDI CAYD; (75kW)	05.15-	FAG	 818 0194 10	818 0194 10			
			 right	825 0361 10			
			 right;  ; PR. IMO	825 0372 10			
			 left	825 0362 10			
			 left;  ; PR. IMO	825 0371 10			
				840 0169 10			
			 right	840 1156 10			
			 left	840 1155 10			
			1.6 CWVA; (81kW)	11.15-		 530 0592 10	530 0592 10
						 531 0882 10	531 0882 10
 532 0753 10	532 0753 10						
 529 0208 10	529 0208 10						
 535 0155 10	535 0155 10						
 FB 6PK737	FB 6PK737						
 420 0254 10	420 0254 10						
 16x	422 0236 10						
 16x 12 mm	771 0344 30						
FAG	 right  ; G5	89,9 mm					
	  ; G5	100 mm					
	 right  ; G5	SET 772 0491 30					
	  ; G5	SET 772 0250 30					
		814 0076 10					
	 right;  ; PR. IMO	825 0372 10					
	 left;  ; PR. IMO	825 0371 10					
		840 0169 10					
	 right	840 1156 10					
	 left	840 1155 10					
2.0 TDI CUUF; DFSC; DFSF; (55kW)	05.15-	LUK			GearBOX G5;  0A4;  ID QYF	462 0333 10	
			 CUUF DFSF	623 3534 00			
				623 3534 00			
				 530 0650 10	530 0650 10		
				 531 0894 10	531 0894 10		
				 532 0161 10	532 0161 10		
				 532 0623 10	532 0623 10		
				 529 0167 10	529 0167 10		
				 535 0124 10	535 0124 10		
				 538 0733 10	538 0733 10		
		 420 0222 10		420 0222 10			
		 16x		422 0102 10			
		 16x 12 mm		713 6106 10			
		FAG	  1ZA,1ZE	136 mm			
			  1ZA, 1ZE	136 mm			
			  0E1, 0E2	Set 713 6108 30			
			  0E1,0E2	Set 713 6108 30			
			 left  ; 01.16  ; G5	771 0567 30			
			  ; G5; PR. 0E1	771 0360 30			
			 100 mm				
			 left  ; 01.16  ; G5	SET 772 0496 30			
			  ; G5	SET 772 0250 30			
				814 0076 10			
			 818 0194 10	818 0194 10			
			 right	825 0361 10			
			 right;  ; PR. IMO	825 0372 10			
			 left	825 0362 10			
			 left;  ; PR. IMO	825 0371 10			
				840 0169 10			
			 right	840 1156 10			
 left	840 1155 10						
2.0 TDI 4motion DFSC; (55kW)	11.15-			 530 0650 10	530 0650 10		
				 530 0650 30	530 0650 30		
		 531 0894 10		531 0894 10			
		 532 0161 10		532 0161 10			
		 529 0167 10		529 0167 10			



			SCHAEFFLER
--	--	--	-------------------

VW

CADDY IV (SAA, SAB, SAH, SAJ)



























































































































2.0 TDI 4motion DFSC; (55kW)	11.15-	 FAG	# F-551406.XX	 535 0124 10
			16x	 538 0733 10
			 12 mm	 420 0222 10
			16x	 422 0102 10
			 Set	 713 6106 10
			 814 0076 10	 818 0194 10
			right	 825 0361 10
			right; ; PR. IM0	 825 0372 10
			left	 825 0362 10
			left; ; PR. IM0	 825 0371 10
			 840 0169 10	 840 1156 10
			right	 840 1155 10
			left	
			2.0 TDI CUUD; DFSD; (75kW)	05.15-
	 462 0333 10			
	 623 3534 00			
DSG	 415 0744 09			
2CT	 411 0133 10			
	 530 0650 10			
	 530 0650 30			
	 531 0894 10			
	 532 0161 10			
	 532 0623 10			
; A/C	 529 0167 10			
# F-551406.XX	 535 0124 10			
	 538 0733 10			
16x	 420 0222 10			
 12 mm	 422 0102 10			
16x	 Set			
; 1ZA, 1ZE	 713 6106 10			
 136 mm	 Set			
; 1ZE, 1ZA	 713 6106 10			
 136 mm	 Set			
; OE1, OE2	 713 6108 30			
; OE1, OE2	 Set			
left ; 01.16 →; G5	 771 0567 30			
; G6				
left ; 01.16 →; G5	 SET			
; G6	 772 0496 30			
	 814 0076 10			
	 818 0194 10			
right	 825 0361 10			
right; ; PR. IM0	 825 0372 10			
left	 825 0362 10			
left; ; PR. IM0	 825 0371 10			
	 840 0169 10			
right	 840 1156 10			
left	 840 1155 10			
2.0 TDI 4motion CFHF; CLCA; (81kW)	05.15-05.16	 LUK	START/STOP	 600 0299 00
			incl. ; incl. ; SAC	
			LuK	 624 3553 33
			SAC	
			Sachs	 624 3731 33
			SAC	
			START/STOP ; + 624 3553 09/33	 415 0431 10
			START/STOP ; + 624 3553 09/33	 415 0583 10
				 411 0133 10
				 530 0550 10
				 530 0550 32
				 531 0825 10
				 532 0161 10
				 532 0582 10
				 532 0623 10
	 534 0164 10			
# F-553470.XX F-227628.XX	 535 0012 10			
; A/C	 FB 6PK1070			



			SCHAEFFLER
--	---	--	-------------------

VW

CADDY IV (SAA, SAB, SAH, SAJ)















































































































2.0 TDI 4motion CFHF; CLCA; (81kW)	05.15-05.16		16x	 538 0060 10	 420 0222 10			
			 12 mm					
			16x	 422 0102 10	 713 6106 10			
								
			 136 mm					
			 right  ; 01.16 →; G6	 772 0496 30	 814 0076 10			
			 right	 818 0194 10	 825 0361 10			
			 right;  ; PR. IMO	 825 0372 10	 825 0362 10			
			 left	 825 0371 10	 840 0169 10			
			 left;  ; PR. IMO	 840 0169 10	 840 1156 10			
			 right	 840 1156 10	 840 1155 10			
			 left	 840 1155 10				
				 right; G6 ; 01.16 →	 75735S			
				 LuK	 624 3553 33			
			SAC	 Sachs	 624 3731 33			
			SAC	 624 3553 09/33	 415 0583 10			
			2.0 TDI 4motion CUUE; DFSE; (90kW)	05.15-			 411 0133 10	 530 0650 10
							 530 0650 30	 531 0894 10
	 532 0161 10	 532 0623 10						
 ; A/C	 529 0167 10	 535 0124 10						
 # F-551406.XX	 538 0733 10	 420 0222 10						
16x	 422 0102 10	 713 6106 10						
 12 mm								
16x	 422 0102 10	 713 6106 10						
								
 136 mm								
 right  ; 01.16 →; G6	 771 0567 30	 772 0496 30						
 right  ; 01.16 →; G6	 814 0076 10	 818 0194 10						
 right	 825 0361 10	 825 0372 10						
 right;  ; PR. IMO	 825 0362 10	 825 0371 10						
 left	 825 0371 10	 840 0169 10						
 left;  ; PR. IMO	 840 0169 10	 840 1156 10						
 right	 840 1156 10	 840 1155 10						
 left	 840 1155 10							
2.0 TDI CFHC; CLCB; (103kW)	05.15-		START/STOP	 600 0299 00				
			incl.  ; incl.  ; SAC					
			 LuK	 624 3553 33				
			SAC	 Sachs	 624 3731 33			
			SAC	 624 3553 09/33	 415 0431 10			
			START/STOP ; + 624 3553 09/33	 415 0583 10	 415 0744 09			
			START/STOP ; + 624 3553 09/33	 415 0583 10	 411 0133 10			
			 DSG	 415 0744 09				
			 MANU	 411 0133 10				
			2CT					
							 530 0550 10	 530 0550 32
							 531 0825 10	 532 0161 10
							 532 0161 10	 532 0582 10
							 532 0623 10	 534 0164 10
						 ; A/C	 534 0164 10	 535 0012 10
						 # F-553470.XX F-227628.XX	 535 0012 10	 FB 6PK1070
						 ; A/C	 538 0060 10	



			SCHAEFFLER
--	--	--	-------------------

VW

CADDY IV (SAA, SAB, SAH, SAJ)

























































































2.0 TDI CFHC; CLCB; (103kW)	05.15-	FAG	 ;  1ZA,1ZE	 Set	713 6106 10			
			 136 mm					
			 ;  0E1,0E2	 Set	713 6108 30			
			 ;  ; 01.16→; G6		771 0567 30			
			 ;  ; 01.16→; G6	 SET	772 0496 30			
					814 0076 10			
					818 0194 10			
			 right		825 0361 10			
			 right;  ; PR. IM0		825 0372 10			
			 left		825 0362 10			
			 left;  ; PR. IM0		825 0371 10			
					840 0169 10			
			 right		840 1156 10			
			 left		840 1155 10			
			2.0 TDI 4motion CFHC; (103kW)	05.15-	LUK	START/STOP incl.  ; incl.  ; SAC		600 0299 00
 LuK		624 3553 33						
Sachs SAC		624 3731 33						
START/STOP ; + 624 3553 09/33		415 0431 10						
START/STOP ; + 624 3553 09/33		415 0583 10						
 DSG		415 0744 09						
 MANU		411 0133 10						
2CT								
		530 0550 10						
		530 0550 32						
		531 0825 10						
		532 0161 10						
		532 0582 10						
		532 0623 10						
		534 0164 10						
 # F-553470.XX F-227628.XX		535 0012 10						
 ; A/C		FB 6PK1070						
		538 0060 10						
2.0 TDI CUUB; DFSB; (110kW)	05.15-	FAG	 ; 	 Set	713 6106 10			
			 136 mm					
			 right;  ; 01.16→; G6		771 0567 30			
			 right;  ; 01.16→; G6	 SET	772 0496 30			
					814 0076 10			
					818 0194 10			
			 right		825 0361 10			
			 right;  ; PR. IM0		825 0372 10			
			 left		825 0362 10			
			 left;  ; PR. IM0		825 0371 10			
					840 0169 10			
			 right		840 1156 10			
			 left		840 1155 10			
			2.0 TDI CUUB; DFSB; (110kW)	05.15-	LUK	 LuK		624 3553 33
						Sachs SAC		624 3731 33
+ 624 3553 09/33		415 0583 10						
 DSG		415 0744 09						
 MANU		411 0133 10						
2CT								
		530 0650 10						
		530 0650 30						
		531 0894 10						
		532 0161 10						
		532 0623 10						
 ; A/C		529 0167 10						
 # F-551406.XX		535 0124 10						
16x		538 0733 10						
 12 mm		420 0222 10						
16x		422 0102 10						





























			SCHAEFFLER
--	--	--	-------------------

VW

CADDY IV (SAA, SAB, SAH, SAJ)

2.0 TDI CUUB; DFSB; (110kW)	05.15-	FAG	 1ZA,1ZE		713 6106 10			
			 136 mm		713 6106 10			
			 1ZA, 1ZE		713 6108 30			
			 136 mm		713 6108 30			
			 OE1,0E2		771 0567 30			
			 OE1, 0E2		771 0567 30			
			 01.16→; G6 G6		772 0496 30			
			 01.16→; G6		772 0496 30			
			 01.16→; G6		814 0076 10			
			 01.16→; G6 G6		818 0194 10			
			 right		825 0361 10			
			 right; PR. IM0		825 0372 10			
			 left		825 0362 10			
			 left; PR. IM0		825 0371 10			
			 right		840 0169 10			
			 left		840 1156 10			
			2.0 TDI 4motion DFSB; (110kW)	11.15-	LUK	 LuK		624 3553 33
						 SAC		624 3731 33
 Sachs		415 0583 10						
 SAC		415 0744 09						
 624 3553 09/33		411 0133 10						
 DSG								
 MANU								
 2CT								
	 KTT				530 0650 10			
	 KTT+				530 0650 30			
	 olia				531 0894 10			
	 olia				532 0161 10			
	 olia				532 0623 10			
	 olia				529 0167 10			
	 olia				535 0124 10			
	 olia				538 0733 10			
	 olia				420 0222 10			
	 olia				422 0102 10			
FAG	 136 mm		713 6106 10					
	 right		814 0076 10					
	 right		818 0194 10					
	 right; PR. IM0		825 0361 10					
	 left		825 0372 10					
	 left; PR. IM0		825 0362 10					
	 right		825 0371 10					
	 right		840 0169 10					
	 left		840 1156 10					
	 left		840 1155 10					

CRAFTER (SY, SZ)















2.0 TDI DAUB; (75kW)	10.16-		angetr. Agg.: 2.Klimakompressor		532 0565 10
			2. 		535 0124 10
			 F-551406.XX		535 0222 10
2.0 TDI DAUA; (103kW)	09.16-		angetr. Agg.: 2.Klimakompressor		532 0161 10
			2. 		532 0623 10
			 F-551406.XX		532 0565 10
			2. 		535 0124 10
			 F-551623.XX		535 0222 10
2.0 TDI DAVA; (130kW)	09.16-		 KTT		530 0650 10
			 olia		531 0894 10
			 olia		532 0161 10
			 olia		532 0623 10
			 olia		532 0565 10























































			SCHAEFFLER
--	--	--	-------------------

VW

CRAFTER (SY, SZ)

2.0 TDI DAVA; (130kW)	09.16-		⊗# F-551406.XX		535 0124 10
			2. 09.17→		535 0222 10
2.0 TDI 2.0 TDI 4motion DAVA; (130kW)	11.16-				538 0807 10
					530 0650 10
					531 0894 10
					532 0161 10
					532 0623 10
			anetr. Agg.: 2.Klimakompressor		532 0565 10
			2. 09.17→		
			⊗# F-551406.XX		535 0124 10
			2. 09.17→		535 0222 10
			⊗# F-551623.XX		538 0807 10

CRAFTER 30-35/50 (2E/F)



















































































































2.0 TDI CKTB; CSLA; (80kW)	05.11-12.16		G6 ; OCB ; ID MWA MWB MWC MWD MWE MWF	GearBOX	462 0239 10	
			SAC		624 3703 33	
					415 0620 10	
					411 0133 10	
					530 0550 10	
					530 0550 32	
					531 0825 10	
					532 0161 10	
					532 0582 10	
					532 0623 10	
					532 0468 10	
					534 0164 10	
			⊗# F-551406.XX		535 0124 10	
			09.17→ ; A/C		FB 6PK1078	
			09.17→ ; A/C		FB 6PK1613	
		09.17→ ; BM Crafter 30, 35; A/C		FB 6PK1613		
		2. 09.17→ ; 14 V		FB 6PK844		
		2. 09.17→ ; 28 V				
		2. 09.17→ ; 230 V		FB 6PK975		
				538 0060 10		
		16x		420 0222 10		
		12 mm				
		16x		422 0102 10		
				right		821 0700 10
				left		821 0699 10
				; → 1.850 kg		Set 713 6680 10
				96 mm		
				; 1.850 kg →		Set 713 6680 20
				96 mm		
						Set 713 6680 40
right				818 0336 10		
left				818 0335 10		
;				818 0447 10		
↔				825 0327 10		
↔				840 0373 10		
				840 1111 10		
						
2.0 TDI CSLB; (84kW)	11.13-12.16				G6 ; OCB ; ID MWA MWB MWC MWD MWE MWF	GearBOX
		SAC			624 3703 33	
					415 0620 10	
					411 0133 10	
					530 0550 10	
					530 0550 32	
					531 0825 10	
					532 0161 10	
					532 0582 10	
					532 0623 10	
					529 0467 10	
		09.17→ ; A/C			532 0468 10	
					534 0164 10	
		⊗# F-553470.XX F-227628.XX			535 0012 10	
		⊗# F-551406.XX			535 0124 10	
09.17→ ; A/C		FB 6PK1078				
		538 0060 10				



			SCHAEFFLER
--	--	--	-------------------

VW

CRAFTER 30-35/50 (2E/F)















































































2.0 TDI CSLB; (84kW)	11.13-12.16		16x  12 mm		420 0222 10	
			FAG	16x  ;  → 1.850 kg  96 mm		422 0102 10
				16x  ;  1.850 kg →  96 mm		713 6680 10
						713 6680 20
						713 6680 40
						818 0447 10
						825 0327 10
						840 0373 10
						840 1111 10
						462 0239 10
						624 3703 33
						415 0620 10
						411 0133 10
						530 0550 10
		530 0550 32				
		531 0825 10				
		532 0161 10				
		532 0582 10				
		532 0623 10				
		532 0468 10				
		534 0164 10				
		535 0124 10				
		FB 6PK1078				
		FB 6PK1613				
		FB 6PK1613				
		FB 6PK844				
		538 0060 10				
		420 0222 10				
		422 0102 10				
FAG	16x  ;  → 1.850 kg  96 mm		713 6680 10			
	16x  ;  1.850 kg →  96 mm		713 6680 20			
			713 6680 40			
			818 0336 10			
			818 0335 10			
			818 0447 10			
			825 0327 10			
			840 0373 10			
			840 1111 10			
			624 3703 33			
			415 0620 10			
			411 0133 10			
			530 0550 10			
		530 0550 32				
		531 0825 10				
		532 0161 10				
		532 0582 10				
		532 0623 10				
		529 0467 10				
		532 0468 10				
		534 0164 10				
		535 0012 10				
		535 0124 10				
		FB 6PK1078				
		538 0060 10				
		420 0222 10				
		422 0102 10				
FAG	16x ; → 1.850 kg 96 mm		713 6680 10			
	16x ; 1.850 kg → 96 mm		713 6680 20			
			713 6680 40			



			SCHAEFFLER
--	--	--	-------------------

VW

CRAFTER 30-35/50 (2E/F)







































































2.0 TDI CSLC; (103kW)	11.15-12.16	FAG	 Set 713 6680 40	
			 ↔ 840 0373 10	
2.0 TDI CKUC; (105kW)	10.11-12.16	LUK	 GearBOX 462 0239 10	
			 SAC 624 3703 33	
		 415 0620 10		
		 411 0133 10		
		 530 0550 10		
		 530 0550 32		
		 531 0825 10		
		 532 0161 10		
		 532 0582 10		
		 532 0623 10		
		 532 0468 10		
		 534 0164 10		
		 535 0124 10		
		 FB 6PK1078		
		 FB 6PK1613		
		 FB 6PK844		
		 538 0060 10		
		 420 0222 10		
		FAG	 422 0102 10	
			 Set 713 6680 10	
 Set 713 6680 20				
 Set 713 6680 40				
 right 818 0336 10				
 left 818 0335 10				
 818 0447 10				
 ↔ 825 0327 10				
 ↔ 840 0373 10				
 840 1111 10				
LUK	 SAC 626 3130 33			
	 415 0649 10			
	 411 0133 10			
	 530 0550 10			
	 530 0550 32			
	 531 0825 10			
	 532 0161 10			
	 532 0582 10			
	 532 0623 10			
	 532 0468 10			
	 534 0164 10			
	 535 0124 10			
	 FB 6PK1078			
	 FB 6PK1613			
 FB 6PK844				
 538 0060 10				
 420 0222 10				
FAG	 422 0102 10			
	 Set 713 6680 10			
	 Set 713 6680 20			
	 Set 713 6680 40			
	 right 818 0336 10			
	left 818 0335 10			
	818 0447 10			
	↔ 825 0327 10			
	↔ 840 0373 10			
	2.0 TDI CKUB; CSNA; (120kW)	07.11-12.16	LUK	 SAC 626 3130 33
				 415 0649 10
			 411 0133 10	
			 530 0550 10	
			 530 0550 32	
 531 0825 10				
 532 0161 10				
 532 0582 10				
 532 0623 10				
 532 0468 10				
 534 0164 10				
 535 0124 10				
 FB 6PK1078				
 FB 6PK1613				
 FB 6PK844				
 538 0060 10				
 420 0222 10				
FAG	 422 0102 10			
	 Set 713 6680 10			
	 Set 713 6680 20			
	 Set 713 6680 40			
	 right 818 0336 10			
	 left 818 0335 10			
	 818 0447 10			
	 ↔ 825 0327 10			
	 ↔ 840 0373 10			



			SCHAEFFLER
--	---	--	-------------------

VW

CRAFTER 30-35/50 (2E/F)





















































































2.0 TDI CKUB; CSNA; (120kW)	07.11-12.16	FAG			840 1111 10
2.0 TDI 4motion CKUB; CSNA; (120kW)	07.11-12.16	LUK	SAC		626 3130 33
					415 0649 10
					411 0133 10
					530 0550 10
					530 0550 32
					531 0825 10
					532 0161 10
					532 0582 10
					532 0623 10
					532 0468 10
					534 0164 10
					535 0124 10
					FB 6PK1078
					FB 6PK1613
					FB 6PK844
					FB 6PK975
					538 0060 10
					420 0222 10
					422 0102 10
		FAG			713 6680 10
					713 6680 20
					825 0327 10
					840 0373 10
					840 1111 10
2.5 TDI BJJ; BJL; CEBA; CECA; (65-100kW)	04.06-05.13	LUK	G6;  OB7;  ID HQT HQU HQX HQY HQZ HRA G6;  OCB;  ID LCF LCG LCK LCH LCJ LCL G6;  OB7;  ID HQT HQU HQZ HQX HQY HRA	GearBOX	462 0152 10 462 0239 10
					600 0231 00
					incl.  ; incl.  ; SAC
					incl.  ; incl. 
					SAC
					SAC
					415 0335 10
					415 0337 10
					411 0139 11
					530 0482 10
					530 0482 30
					531 0342 30
					532 0111 10
					532 0161 10
					532 0535 10
					532 0536 10
					533 0099 10
					534 0278 10
					535 0012 10
					544 0002 10
					544 0002 20
					FB 6PK2000
					FB 6PK2520
					538 0045 10
					428 0027 30
		FAG			821 0700 10
					821 0699 10
					713 6680 10
					713 6680 20
					713 6680 40
					818 0336 10
					818 0335 10
					818 0447 10
					825 0327 10



			SCHAEFFLER
--	--	--	-------------------

VW

CRAFTER 30-35/50 (2E/F)

2.5 TDI BJJ; BJL; CEBA; CECA; (65-100kW)	04.06-05.13	FAG	 ↔ 	 840 0373 10  840 1111 10
2.5 TDI BJK; CEBB; (80kW)	04.06-05.13	LUK	G6 ;  0B7 ;  ID HQT HQU HQX HQY HQZ HRA G6 ;  0B7 ;  ID HQT HQU HQZ HQX HQY HRA G6 ;  0CB ;  ID LCF LCG LCK LCH LCJ LCL G6 ;  0CB ;  ID LCF LCG LCK LCH LCJ LCL G6 ;  0B7 ;  ID HQT HQU HQZ HQX HQY HRA SEMI incl.  ; incl.  ; SAC incl.  ; incl.  SAC SEMI SAC INA AirComp., A/C für 2. Generator; 2x  F-553470.XX F-227628.XX A/C für 2. Generator; 2x  right left ;  → 1.850 kg  96 mm ;  1.850 kg →  96 mm right left ;  ↔ ↔	GearBOX 462 0152 10 GearBOX 462 0239 10 GearBOX 462 0239 10 SEMI  600 0231 00 incl.  ; incl.  600 0275 00 SEMI  624 3278 33 SEMI  624 3310 33 415 0335 10 415 0337 10 INA  411 0139 11 INA  530 0482 10 INA  530 0482 30 INA  531 0342 30 INA  532 0111 10 INA  532 0161 10 AirComp., A/C  532 0535 10  532 0536 10  533 0099 10  534 0278 10 #  535 0012 10  544 0002 10  544 0002 20  FB 6PK2000  FB 6PK2520  538 0045 10  428 0027 30  821 0700 10  821 0699 10  Set 713 6680 10  Set 713 6680 20  Set 713 6680 40  818 0336 10  818 0335 10  818 0447 10  825 0327 10  840 0373 10  840 1111 10
2.5 TDI BJM; CECB; (120kW)	04.06-07.11	LUK	G6 ;  0B7 ;  ID HQV HQW HRB HRC HRD HRE G6 ;  0CB ;  ID LCF LCG LCK LCH LCJ LCL incl.  ; incl.  ; SAC SEMI incl.  ; incl.  ; SAC SEMI SAC SAC INA AirComp., A/C für 2. Generator; 2x  F-553470.XX F-227628.XX	GearBOX 462 0238 10 GearBOX 462 0239 10 incl.  ; incl.  600 0202 00 SEMI  600 0231 00 SEMI  624 3310 33 SEMI  626 3072 33 415 0336 10 415 0337 10 INA  411 0139 11 INA  530 0482 10 INA  530 0482 30 INA  531 0342 30 INA  532 0111 10 INA  532 0161 10 AirComp., A/C  532 0535 10  532 0536 10  533 0099 10  534 0278 10 #  535 0012 10  544 0002 10







































			SCHAEFFLER
--	--	--	-------------------

VW

CRAFTER 30-35/50 (2E/F)

2.5 TDI
 1.0 BJM; CEGB; (120kW)











































































04.06-07.11

		 ; A/C		544 0002 20	
		 für 2. Generator; 2x 		FB 6PK2000	
				FB 6PK2520	
				538 0045 10	
				428 0027 30	
	FAG	 right			821 0700 10
		 left			821 0699 10
		 ;  → 1.850 kg			713 6680 10
		 96 mm			713 6680 20
		 ;  1.850 kg →			713 6680 40
		 96 mm			713 6680 40
		 right			818 0336 10
		 left			818 0335 10
		 ; 			818 0447 10
		 ↔			825 0327 10
 ↔			840 0373 10		
			840 1111 10		

LT II 28-35/46 (2DM, 20XDAE, 20XDFE)















2.5 TDI
 1.0 BBE; BBF; (61-70kW)

05.01-07.06

				624 3116 00	
				415 0191 10	
				411 0133 11	
				512 0038 10	
		INJP			530 0062 10
					530 0173 10
		 → 2D-6-020 000			530 0483 10
		INJP 			530 0173 30
		INJP; ↓ down			530 0483 30
		INJP; ↑ up			531 0343 30
					531 0276 30
		 ;  2D-Y-009 087 →; A/C ; OPTION			529 0244 10
					532 0169 10
					533 0020 10
				534 0011 10	
			544 0002 10		
			544 0002 20		
 ;  2D-Y-009 087 →; A/C			FB 6PK1718		
 ;  → 2D-Y-009 086; A/C			FB 6PK1750		
 2. 			FB 6PK2080		
 ; A/C			FB 6PK2145		
 2. HYDP;  2D-Y-009 206 →			FB 6PK2145		
			538 0045 10		
			428 0027 30		
FAG	 right			821 0594 10	
	 left			821 0593 10	
				713 6676 00	
	 84 mm			713 6670 30	
	 ; 			713 6670 30	
	 84 mm			713 6670 40	
	 ; 			713 6670 40	
	 90 mm			814 0038 10	
				814 0039 10	
	 right			818 0183 10	
	 left			818 0182 10	
				818 0177 10	
				825 0123 10	
				840 0151 10	
				840 1173 10	

2.8 TDI
 1.0 AUH; BCQ; (116kW)

05.01-06.06















































































	 → 2#036000; + 415 0208 10			624 3131 00
	 2#036001 →			
	SAC			
	 → 2#036000; + 624 3131 00			415 0208 10
 2#036001 →				
				532 0789 10
				534 0548 10
	 # F-227820.08/.09/.10 F-227820.12/.13			535 0052 10

















































			SCHAEFFLER
--	--	--	-------------------

VW

LT II 28-35/46 (2DM, 20XDAE, 20XDFE)

2.8 TDI AUH; BCQ; (116kW)	05.01-06.06	 FAG	 ; A/C		FB 6PK1685
			 ; A/C		FB 6PK2155
			 right		821 0594 10
			 left		821 0593 10
					713 6676 00
					713 6670 30
			 84 mm		814 0038 10
					814 0039 10
			 right		818 0183 10
			 left		818 0182 10
					818 0177 10
					825 0123 10
					840 0151 10
					840 1173 10
			2.8 TDI AUH; BCQ; (116kW)	04.02-07.06	
 2#036001→ SAC		415 0208 10			
 →2#036000; + 624 3131 00		415 0208 10			
 2#036001→		415 0208 10			
					532 0789 10
					534 0548 10
	 # F-227820.08/09/10 F-227820.12/13				535 0052 10
	 ; AUH BCQ; A/C				FB 6PK1685
	 ; A/C				FB 6PK2155
	 right				821 0594 10
	 left				821 0593 10
					713 6676 00
	 ; 				713 6670 30
	 84 mm				713 6670 40
	 ; 				713 6670 40
 90 mm		713 6670 40			
		814 0038 10			
		814 0039 10			
 right		818 0183 10			
 left		818 0182 10			
		818 0177 10			
		825 0123 10			
		840 0151 10			
		840 1173 10			

TRANSPORTER T5 (7H_, 7E_)













































































































































1.9 TDI BRR; (62kW)	01.06-11.09		incl.  ; incl.  ; SAC		600 0169 00
			 LuK		623 3082 21
			SAC; incl. 		415 0250 10
			+ 623 3082 00/21		411 0133 10
					512 0366 10
					530 0201 10
					530 0201 33
					531 0565 30
					532 0349 10
					534 0151 10
				535 0012 10	
				544 0083 10	
				544 0083 20	
		 ; A/C		FB 6DPK1215	
		 ; A/C		FB 6PK1138	
				538 0054 10	
		1x		428 0039 30	
		1x		559 0069 10	
			 right;  →7H...C...000000; 3.200		821 0811 10
			 left;  →7H...C...000000; 3.200		821 0812 10
			713 6107 60		
 85 mm			713 6107 60		
 right  ; 			771 0511 30		
 left  ; G5			771 0419 30		
 108 mm		771 0419 30			
 ; G5		771 0477 30			



			SCHAEFFLER
--	--	--	-------------------

VW

TRANSPORTER T5 (7H_, 7E_)























































































1.9 TDI BRR; (62kW)	01.06-11.09	FAG	 right  ;  MANU	 SET	772 0447 30
			 right  ;  G5	 SET	772 0457 30
			 ;  G5	 SET	772 0431 30
				 REP	815 0078 30
			 ; 		818 0199 10
			 ; 3.000		825 0266 10
					840 0177 10
			 right		840 0526 10
			 left		840 0524 10
			 right		840 0843 10
			 left		840 0842 10
					600 0169 00
					623 3082 21
					415 0250 10
			1.9 TDI AXC; (63kW)	04.03-11.09	LUK
 LuK		623 3082 21			
SAC; incl. 		415 0250 10			
 623 3082 00/21		411 0133 10			
		512 0366 10			
		530 0201 10			
		530 0201 33			
		531 0565 30			
		532 0349 10			
 ;  → 7J-6-022 356		534 0132 30			
 ;  7J-6-022 357 →		534 0151 10			
 # F-553470.XX F-227628.XX		535 0012 10			
 7H-3-000 001 →  7H-5-075 000		544 0065 10			
 7J-3-000 001 →  7J-5-022 000		544 0065 10			
 7H-5H081 001 →		544 0083 10			
 7H-5X022 401 →		544 0083 20			
 7H-5H081 001 →		544 0083 20			
 7H-5X022 401 →		544 0083 20			
 ;  → 7H-6H079 890 7H-6X022 356; A/C		FB 6DPK1195			
 ;  7H-6H079 891 →; A/C		FB 6DPK1215			
 ;  7H-6X022 357 →; A/C		FB 6PK1120			
 ;  → 7H-6H079 890; A/C		FB 6PK1120			
 ;  → 7H-6X022 356; A/C		FB 6PK1138			
 ;  7H-6H079 891 →; A/C		FB 6PK1138			
 ;  7H-6X022 357 →; A/C		FB 6PK1138			
		538 0054 10			
1x		428 0042 30			
1x		559 0069 10			
FAG	 right;  → 7H...C...000000; 3.200				821 0811 10
	 left;  → 7H...C...000000; 3.200				821 0812 10
		 Set			713 6107 60
	 85 mm				771 0511 30
	 right  ;  MANU				771 0419 30
	 left  ;  G5				771 0419 30
	 108 mm				771 0477 30
	 right  ;  MANU	 SET			772 0447 30
	 right  ;  G5	 SET			772 0457 30
	 ;  G5	 SET			772 0431 30
		 REP			815 0078 30
	 ; 				818 0199 10
	 ; 3.000				825 0266 10
					840 0177 10
	 right				840 0526 10
	 left				840 0524 10
	 right				840 0843 10
	 left		840 0842 10		
			600 0169 00		
			623 3082 21		
			415 0250 10		
			411 0133 10		
			512 0366 10		
			530 0201 10		
			530 0201 33		
			531 0565 30		
			532 0349 10		



			SCHAEFFLER
--	--	--	-------------------

VW

TRANSPORTER T5 (7H_, 7E_)























































































































































<p>1.9 TDI BRS; (75kW)</p>	<p>06.06-11.09</p>			 534 0151 10		
			 # F-553470.XX F-227628.XX	 535 0012 10		
			 544 0083 10	 544 0083 20		
			 FB 6DPK1215	 FB 6DPK1215		
			 FB 6PK1138	 FB 6PK1138		
			 538 0054 10	 428 0039 30		
			 559 0069 10	 821 0811 10		
			 821 0812 10	 713 6107 60		
			 771 0511 30	 771 0419 30		
			 771 0477 30	 772 0447 30		
		 772 0457 30	 772 0431 30			
		 815 0078 30	 818 0199 10			
		 825 0266 10	 840 0177 10			
		 840 0526 10	 840 0524 10			
		 840 0843 10	 840 0842 10			
		 840 0842 10	 600 0169 00			
		 623 3082 21	 415 0250 10			
		<p>1.9 TDI AXB; (77kW)</p>	<p>04.03-11.09</p>		 incl.  ; SAC	 600 0169 00
					 LuK	 623 3082 21
					 SAC; incl. 	 415 0250 10
 + 623 3082 00/21	 411 0133 10					
	 512 0366 10					
	 530 0201 10					
	 530 0201 33					
	 531 0565 30					
	 532 0349 10					
 ;  → 7J-6-022 356	 534 0132 30					
 ;  → 7J-6-022 357 →	 534 0151 10					
 # F-553470.XX F-227628.XX	 535 0012 10					
 544 0065 10	 544 0083 10					
 544 0083 20	 FB 6DPK1195					
 FB 6DPK1215	 FB 6PK1120					
 FB 6PK1138	 538 0054 10					
 428 0042 30	 559 0069 10					
 821 0811 10	 821 0812 10					
 713 6107 60	 771 0511 30					
 771 0419 30	 771 0419 30					
 771 0419 30	 771 0419 30					
 771 0419 30	 771 0419 30					
 771 0419 30	 771 0419 30					



			SCHAEFFLER
--	---	--	-------------------

VW

TRANSPORTER T5 (7H_, 7E_)











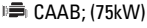

























































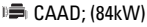









































































1.9 TDI AXB; (77kW)	04.03-11.09	FAG	 ; G5		771 0477 30		
			 right 		772 0447 30		
			 right 		772 0457 30		
			 ; G5		772 0431 30		
					815 0078 30		
					818 0199 10		
			 ; 3.000		825 0266 10		
					840 0177 10		
			 right		840 0526 10		
			 left		840 0524 10		
			 right		840 0843 10		
			 left		840 0842 10		
					623 3082 21		
					623 3765 00		
			2.0 TDI CAAA; (62kW)	09.09-08.15	LUK	 →B#500000	
SAC; incl. 		623 3765 00					
 C#000001 →		623 3765 00					
SAC		415 0557 10					
 C#000001 →; START/STOP		415 0557 10					
 →B#500000		415 0574 10					
 C#000001 →; START/STOP		415 0574 10					
		411 0133 10					
		512 0366 10					
		530 0550 10					
							530 0550 32
							531 0825 10
							532 0161 10
							532 0582 10
							532 0623 10
					 ; +  ; A/C		529 0240 10
							532 0468 10
							534 0164 10
					 # F-551406.XX		535 0124 10
					 ; A/C		FB 6PK1078
					 ; A/C		FB 6PK1555
							538 0060 10
					16x		420 0222 10
					 12 mm		422 0102 10
					16x		422 0102 10
FAG			 right;  →7H...C...000000; 3.200		821 0811 10		
			 left;  →7H...C...000000; 3.200		821 0812 10		
					713 6107 60		
			 85 mm		771 0419 30		
			 left  ; →12.10; G5		771 0419 30		
			 108 mm		771 0419 30		
			 ; →06.13; G6 G7		771 0476 30		
			 ; →06.13; G5		771 0477 30		
			 ; 04.10 →; G5		771 0477 30		
			 right  ; G5		772 0457 30		
			 ; →06.13; G5		772 0431 30		
			 ; 04.10 →; G5		772 0431 30		
			 ; →06.13; G6 G7		772 0432 30		
					815 0078 30		
					818 0199 10		
			 ; 3.000		825 0266 10		
					840 0177 10		
			 right		840 0843 10		
			 left		840 0842 10		
			2.0 TDI CAAB; (75kW)	09.09-08.15	LUK	 →B#500000	
SAC; incl. 		623 3765 00					
 C#000001 →		623 3765 00					
SAC		415 0557 10					
 C#000001 →; START/STOP		415 0557 10					
 →B#500000		415 0574 10					
 C#000001 →; START/STOP		415 0574 10					
		411 0133 10					
		512 0366 10					
		530 0550 10					
							530 0550 32
							531 0825 10
							532 0161 10
							532 0582 10
							532 0582 10



			SCHAEFFLER
--	---	--	-------------------

VW

TRANSPORTER T5 (7H_, 7E_)











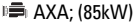











































































































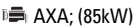











































































2.0 TDI  CAAB; (75kW)	09.09-08.15		 ; +  ; A/C		532 0623 10
					529 0240 10
					532 0468 10
					534 0164 10
			 # F-551406.XX		535 0124 10
			 ; A/C		FB 6PK1078
			 ; A/C		FB 6PK1555
					538 0060 10
			16x		420 0222 10
			 12 mm		
		16x		422 0102 10	
		FAG	 right;  →7H...C...000000; 3.200		821 0811 10
			 left;  →7H...C...000000; 3.200		821 0812 10
				 Set	713 6107 60
			 85 mm		771 0419 30
			 left  ; →12.10; G5		
			 108 mm		
			  ; 04.10→; G5		771 0477 30
			 right  ; G5	 SET	772 0457 30
			  ; 04.10→; G5	 SET	772 0431 30
	 REP		815 0078 30		
 ; 		818 0199 10			
 ; 3.000		825 0266 10			
		840 0177 10			
 right		840 0843 10			
 left		840 0842 10			
2.0 TDI  CAAD; (84kW)	05.11-08.15		 →B#500000		623 3082 21
			SAC; incl. 		623 3765 00
			 C#000001→		
			SAC		415 0557 10
			START/STOP		415 0574 10
			START/STOP		411 0133 10
					512 0366 10
					530 0550 10
					530 0550 32
					531 0825 10
				532 0161 10	
				532 0582 10	
				532 0623 10	
		 ; +  ; A/C		529 0240 10	
				532 0468 10	
				534 0164 10	
		 # F-551406.XX		535 0124 10	
		 ; A/C		FB 6PK1078	
		 ; A/C		FB 6PK1555	
				538 0060 10	
16x		420 0222 10			
 12 mm					
16x		422 0102 10			
FAG	 right;  →7H...C...000000; 3.200		821 0811 10		
	 left;  →7H...C...000000; 3.200		821 0812 10		
		 Set	713 6107 60		
	 85 mm		771 0476 30		
	  ; →06.13; G6 G7		771 0477 30		
	  ; →06.13; G5	 SET	772 0457 30		
	 right  ; 	 SET	772 0431 30		
	  ; →06.13; G5	 SET	772 0432 30		
	  ; →06.13; G6 G7	 SET	772 0432 30		
		 REP	815 0078 30		
 ; 		818 0199 10			
; 3.000		825 0266 10			
		840 0177 10			
right		840 0843 10			
left		840 0842 10			
2.0  AXA; (85kW)	11.03-08.15				623 3160 00
					512 0366 10
					530 0171 10
		530 0171 31			



			SCHAEFFLER
--	---	--	-------------------

VW

TRANSPORTER T5 (7H_, 7E_)

2.0  AXA; (85kW)	11.03-08.15			 531 0203 20
				 533 0076 30
			# F-553470.XX F-227628.XX	 535 0012 10
			 7H-3-000-001→	 544 0003 10
			 ; A/C	 FB 6DPK1195
				 FB 6PK1120
			8x	 538 0038 10
			 35 mm	 420 0043 10
			1x	 559 0067 10
			FAG	 821 0811 10
			 right;  →7H...C...000000; 3.200	 821 0812 10
			 left;  →7H...C...000000; 3.200	 713 6107 60
				 Set
			 85 mm	 771 0511 30
			 right  ←; MY 2009;  MANU	 771 0419 30
			 left  ←; →11.09;  MANU	 771 0419 30
			 108 mm	 771 0419 30
			 left  ←; →12.10; G5	 771 0477 30
			 108 mm	 771 0477 30
			  ; G5	 771 0477 30
			  ; MANU	 771 0477 30
			 right  ←;  MANU ; MY 2009	 SET
			 right  ←; G5	 772 0447 30
			 right  ←;  MANU	 772 0457 30
			  ; MANU	 SET
			  ; G5	 772 0431 30
				 SET
				 772 0431 30
	 REP			
	 815 0078 30			
	 818 0199 10			
 ; 3.000	 825 0266 10			
	 840 0177 10			
 right	 840 0526 10			
 left	 840 0524 10			
 right	 840 0843 10			
 left	 840 0842 10			
8x	 420 0043 10			
 35 mm	 814 0187 10			
FAG	 814 0188 10			
 ; + 814 0188 10 713 0425 20	 814 0188 10			
 153 mm	 814 0188 10			
 ; + 814 0187 10 713 0425 20	 814 0188 10			
 160 mm	 825 0266 10			
 ; 3.000	 840 0177 10			
	 840 0843 10			
 right	 840 0842 10			
 left	 840 0842 10			
2.0 BiFuel  AXA; (85kW)	05.11-08.15		8x	 420 0043 10
			 35 mm	 814 0187 10
			FAG	 814 0188 10
			 ; + 814 0188 10 713 0425 20	 814 0188 10
			 153 mm	 814 0188 10
			 ; + 814 0187 10 713 0425 20	 814 0188 10
			 160 mm	 825 0266 10
			 ; 3.000	 840 0177 10
				 840 0843 10
			 right	 840 0842 10
			 left	 840 0842 10
2.0 TDI  CAAE; CCHB; (100kW)	05.10-08.15		G6 ;  0A5 ;  ID KUP PAP	GearBOX
			 CAAE; →05.12;  135	 462 0200 10
			 CAAE; 06.12→; START/STOP ;  135	 600 0321 00
			 CCHB;  →C#500000	
			 CCHB;  D#000001→; START/STOP	
			incl.   ; SAC	
			 DSG ;  ID PSP	 602 0018 00
			 DSG ;  ID SDG	
			SAC	 624 3517 33
			 CAAE; →05.12;  135	 415 0540 10
			 CAAE; 06.12→; START/STOP ;  135	
			 CCHB;  →C#500000	
			 CCHB;  D#000001→; START/STOP	
			 CCHB; 06.10→;  DSG	 415 0615 09
			 CAAE;  DSG	
			incl.  	
			 CCHB; →05.10;  DSG	 415 0618 09
			incl.  	
			 CAAE; 06.12→; START/STOP ;  132	 415 0734 10
			 CCHB;  D#000001→; START/STOP	
				 411 0133 10
				 512 0366 10
				 530 0550 10
				 530 0550 32
				 531 0825 10
				 532 0161 10
				
				
				
				
				



			SCHAEFFLER
--	--	--	-------------------

VW

TRANSPORTER T5 (7H_, 7E_)



2.0 TDI
 CAAE; CCHB; (100kW)

05.10-08.15

	; + ; A/C ; A/C ; A/C # F-551406.XX ; A/C ; A/C 16x; CCHB CAAE 12 mm 16x 12 mm 16x; CCHB CAAE 16x	532 0582 10 532 0623 10 529 0240 10 532 0468 10 534 0164 10 535 0124 10 FB 6PK1078 FB 6PK1555 538 0060 10 420 0222 10 420 0222 10 422 0102 10 422 0102 10
FAG	right; →7H...C...000000; 3.200 left; →7H...C...000000; 3.200 85 mm →06.13; G6 G7 →07.13; G5 →07.13; G5 →06.13; G6 G7 G6 ; ; 3.000 right left	821 0811 10 821 0812 10 Set 713 6107 60 771 0476 30 771 0477 30 SET 772 0431 30 SET 772 0432 30 SET 772 0458 30 REP 815 0078 30 818 0199 10 825 0266 10 840 0177 10 840 0843 10 840 0842 10

2.0 TDI 4motion
 CAAE; CCHB; (100kW)

05.10-08.15





































































	G6 ; OA5 ; ID KQK PAQ CAAE; →05.12; 135 CAAE; 06.12→; START/STOP ; 135 incl. ; incl. ; SAC CAAE; →05.12; 135 CAAE; 06.12→; START/STOP ; 135 CCHB; →C#500000 CCHB; D#000001→; START/STOP incl. ; incl. ; SAC SAC CAAE; →05.12; 135 CAAE; 06.12→; START/STOP ; 135 CCHB; →C#500000 CCHB; D#000001→; START/STOP CAAE; 06.12→; START/STOP ; 132 CCHB; D#000001→; START/STOP	GearBOX 462 0200 10 600 0321 00 600 0321 00 624 3517 33 415 0540 10 415 0734 10
	; + ; A/C ; A/C ; A/C # F-551406.XX ; A/C ; A/C 16x; CCHB CAAE 12 mm 16x 12 mm 16x; CCHB CAAE 16x	411 0133 10 512 0366 10 530 0550 10 530 0550 32 531 0825 10 532 0161 10 532 0582 10 532 0623 10 529 0240 10 532 0468 10 534 0164 10 535 0124 10 FB 6PK1078 FB 6PK1555 538 0060 10 420 0222 10 420 0222 10 422 0102 10 422 0102 10 821 0811 10 821 0812 10
FAG	right; →7H...C...000000; 3.200 left; →7H...C...000000; 3.200	821 0811 10 821 0812 10



			SCHAEFFLER
--	---	--	-------------------

VW

TRANSPORTER T5 (7H_, 7E_)

















































2.0 TDI 4motion CAAC; CCHB; (100kW)	05.10-08.15	FAG	  Set 713 6107 60
			 85 mm
			 →06.13; G6 G7
			 →06.13; G6 G7
			 →; G6
			 →; G6
			
			
			 ; 3.000
			 right
			 left
			
			
			
			2.0 TDI CAAC; CCHA; (103kW)
 600 0321 00			
			
 →05.12; 135			
 CAAC; 06.12→; START/STOP; 135			
 CCHA; →C#500000			
 CCHA; D#000001→; START/STOP			
incl. ○; incl. ■■■■■; SAC			
 DSG; ID PSP			
 DSG; ID SDG			
SAC			
 CAAC; →05.12; 135			
 CAAC; 06.12→; START/STOP; 135			
 CCHA; →C#500000			
 CCHA; D#000001→; START/STOP			
 CAAC; 02.10→; DSG			
 CAAC; EURO 5; 06.10→; DSG			
 CCHA; 06.10→; DSG			
incl. ■■■■■			
 CAAC; →01.10; DSG			
 CAAC; EURO 5; →05.10; DSG			
 CCHA; →05.10; DSG			
incl. ■■■■■			
 CAAC; 06.12→; START/STOP; 132			
 CCHA; D#000001→; START/STOP			
 MANU			
			
			
			
			
			
			
			
			
			
			
			
			
			
			
			
			
			
			
			
			
			
			
			
			
			
			
			
			
			
			
			
			



			SCHAEFFLER
--	--	--	-------------------

VW

TRANSPORTER T5 (7H_, 7E_)





















































































































































2.0 TDI CAAC; CCHA; (103kW)	09.09-08.15	FAG	right		840 0843 10	
			left		840 0842 10	
2.0 TDI 4motion CAAC; CCHA; (103kW)	09.09-08.15	LUK	G6 ; ID 0A5 ; ID KQK NEE PAQ PAR PAW	GearBOX	462 0200 10	
			CAAC; →05.12; 135		600 0321 00	
			CAAC; 06.12→; START/STOP ; 135			
			CCHA; →C#500000			
			CCHA; D#000001→; START/STOP			
			incl. ○; incl. ■■■■; SAC			
			SAC		624 3517 33	
			CAAC; →05.12; 135		415 0540 10	
			CAAC; 06.12→; START/STOP ; 135			
			CCHA; →C#500000			
			CCHA; D#000001→; START/STOP			
			CAAC; 06.12→; START/STOP ; 132		415 0734 10	
			CCHA; D#000001→; START/STOP			
					411 0133 10	
					512 0366 10	
					530 0550 10	
					530 0550 32	
					531 0825 10	
					532 0161 10	
					532 0582 10	
					532 0623 10	
				■ ■ ■ ; + ○ ; A/C		529 0240 10
				■ ■ ■		532 0468 10
				■ ■ ■		534 0164 10
				■ ■ # F-551406.XX		535 0124 10
				■ ■ ■ ; A/C		FB 6PK1078
				■ ■ ■ ; A/C		FB 6PK1555
					538 0060 10	
			16x		420 0222 10	
			12 mm			
			16x		422 0102 10	
		FAG	right; →7H...C...000000; 3.200		821 0811 10	
				left; →7H...C...000000; 3.200		821 0812 10
					Set	713 6107 60
				85 mm		
				→06.13; G6 G7		771 0476 30
				→04.10→06.13		771 0476 30
				→06.13; G6 G7	SET	772 0432 30
				→04.10→06.13	SET	772 0432 30
				→G6	SET	772 0458 30
					REP	815 0078 30
						818 0199 10
				3.000		825 0266 10
			right		840 0843 10	
			left		840 0842 10	
2.0 TSI CJKB; (110kW)	07.12-08.15	LUK	G6 ; ID 0A5 ; ID PAV	GearBOX	462 0200 10	
					512 0366 10	
					532 0694 10	
					534 0333 10	
				■ ■ # 1000555 1013776 920851		535 0210 10
				16x		420 0224 10
				12 mm		
				8x; 		422 0058 10
				1x		427 0016 10
				1x	OILP	553 0388 10
				1x	KIT	559 0196 10
				1x		711 0294 10
			FAG	right; →7H...C...000000; 3.200		821 0811 10
					left; →7H...C...000000; 3.200	
					Set	713 6107 60
				85 mm		
				→06.13; G6		771 0476 30
				→06.13; G6 G7		771 0476 30
				→06.13; G6	SET	772 0432 30
				→06.13; G6 G7	SET	772 0432 30
				→G6	SET	772 0458 30
					REP	815 0078 30



			SCHAEFFLER
--	--	--	-------------------

VW

TRANSPORTER T5 (7H_, 7E_)















































































































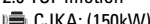



























2.0 TSI CJKB; (110kW)	07.12-08.15	FAG	 ; 		818 0199 10
			 ; 3.000		825 0266 10
2.0 BITDI CFCA; (132kW)	09.09-08.15	LUK	 right		840 0177 10
			 left		840 0843 10
2.0 BITDI 4motion CFCA; (132kW)	09.09-08.15	LUK	G6 ;  0A5;  ID KUP MKB NTF PAT	GearBOX	462 0200 10
			 DSG;  PSP		602 0018 00
			 DSG;  SDG		624 3783 33
			SAC		624 3783 33
		FAG	 DSG		415 0618 09
			incl. 		415 0853 10
			START/STOP		415 0853 10
			 MANU		411 0133 10
					512 0366 10
					530 0550 10
					530 0550 32
					531 0825 10
					532 0161 10
					532 0582 10
					532 0623 10
					529 0240 10
			 ; +  ; A/C		532 0468 10
					534 0164 10
					535 0124 10
			 # F-551406.XX		535 0124 10
			 ; A/C		FB 6PK1078
			 ; A/C		FB 6PK1555
					538 0060 10
			16x		420 0222 10
			 12 mm		422 0102 10
			16x		821 0811 10
		FAG	 right;  →7H...C...000000; 3.200		821 0812 10
			 left;  →7H...C...000000; 3.200		713 6107 60
		FAG			Set
			 85 mm		771 0419 30
		FAG	 left  ←; →12.10; G5		771 0476 30
			 108 mm		771 0477 30
		FAG	 ←; →06.13; G6 G7		772 0457 30
			 ←; 04.10→07.13; G5		772 0431 30
		FAG	 right  ←; G5		SET
			 ←; 04.10→07.13; G5		SET
		FAG	 ←; →06.13; G6 G7		SET
			 ←; G6		REP
		FAG			815 0078 30
			 ; 		818 0199 10
		FAG	 ; 3.000		825 0266 10
					840 0177 10
		FAG	 right		840 0843 10
			 left		840 0842 10
2.0 BITDI 4motion CFCA; (132kW)	09.09-08.15	LUK	G6 ;  0A5;  ID KQK MKA NTH PAS	GearBOX	462 0200 10
			 DSG;  PSR		602 0018 00
		LUK	 DSG;  SDD		624 3783 33
			SAC		624 3783 33
		LUK	 DSG		415 0618 09
			incl. 		415 0853 10
			START/STOP		415 0853 10
			 MANU		411 0133 10
					512 0366 10
					530 0550 10
					530 0550 32
					531 0825 10
					532 0161 10
					532 0582 10
					532 0623 10
			; + ; A/C		529 0240 10
					532 0468 10
					534 0164 10
					535 0124 10
			; A/C		FB 6PK1078
			; A/C		FB 6PK1555



			SCHAEFFLER
--	--	--	-------------------

VW

TRANSPORTER T5 (7H_, 7E_)





























































2.0 BiTDI 4motion  CFCA; (132kW)	09.09-08.15		16x		538 0060 10		
			 12 mm		420 0222 10		
			16x		422 0102 10		
			 right;  →7H...C...000000; 3.200		821 0811 10		
			 left;  →7H...C...000000; 3.200		821 0812 10		
			 	 Set	713 6107 60		
			 85 mm		771 0476 30		
			  ; →06.13; G6 G7		772 0432 30		
			  ; →06.13; G6 G7		772 0458 30		
			  ;  ; G6		815 0078 30		
				818 0199 10			
		 ; 		825 0266 10			
		 ; 3.000		840 0177 10			
				840 0843 10			
		 right		840 0842 10			
		 left		462 0200 10			
				512 0366 10			
		2.0 TSI  CJKA; (150kW)	05.11-08.15		G6 ;  OA5 ;  ID MQX PAV	GearBOX	532 0694 10
							534 0333 10
							535 0210 10
 # 1000555 1013776 920851					FB 6PK1183		
 ; A/C					FB 6PK1580		
 ; A/C					420 0224 10		
16x					422 0058 10		
 12 mm					427 0016 10		
8x; 					553 0388 10		
1x					559 0196 10		
1x				711 0294 10			
1x				821 0811 10			
1x				821 0812 10			
 right;  →7H...C...000000; 3.200				713 6107 60			
 left;  →7H...C...000000; 3.200				771 0476 30			
 				771 0476 30			
 85 mm				772 0432 30			
  ; →06.13; G6				772 0432 30			
  ; →06.13; G6 G7				772 0458 30			
  ; →06.13; G6 G7				815 0078 30			
  ; G6		818 0199 10					
		825 0266 10					
 ; 		840 0177 10					
 ; 3.000		840 0843 10					
		840 0842 10					
 right		512 0366 10					
 left		532 0694 10					
2.0 TSI 4motion  CJKA; (150kW)	07.11-08.15				534 0333 10		
					535 0210 10		
					FB 6PK1183		
			 # 1000555 1013776 920851		FB 6PK1580		
			 ; A/C		420 0224 10		
			 ; A/C		422 0058 10		
			16x		427 0016 10		
			 12 mm		553 0388 10		
			8x; 		559 0196 10		
			1x		711 0294 10		
		1x		821 0811 10			
		1x		821 0812 10			
		1x		713 6107 60			
		 right;  →7H...C...000000; 3.200		771 0476 30			
		 left;  →7H...C...000000; 3.200		772 0432 30			
		 		772 0432 30			
		 85 mm		772 0458 30			
		  ; →06.13; G6 G7		815 0078 30			
		 ; →06.13; G6 G7		818 0199 10			
				825 0266 10			
;		840 0177 10					
; 3.000							



			SCHAEFFLER
--	---	--	-------------------

VW

TRANSPORTER T5 (7H_, 7E_)











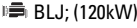







































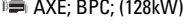















2.0 TSI 4motion CJKA; (150kW)	07.11-08.15	FAG	right		840 0843 10
			left		840 0842 10
2.5 TDI AXD; AXE; BNZ; (96kW)	04.03-11.09	LUK	G6 ; 0A5 ; ID FNQ FXV GWB GWC HRU HRV JFS JFT KCQ KCR		462 0199 10
			G6 ; 0A5 ; ID KPE		462 0200 10
			incl. O; incl. SAC		600 0125 00
			SAC		624 3156 34
					415 0271 10
					411 0133 11
					512 0366 10
					535 0118 10
					538 0338 10
					428 0040 30
		FAG	AXD		428 0044 30
			BNZ		428 0044 30
			right; →7H...C...000000; 3.200		821 0811 10
			left; →7H...C...000000; 3.200		821 0812 10
			85 mm		713 6107 60
			right; G6		771 0512 30
			; G6 ; AUTOM G6		771 0476 30
			; G6 ; AUTOM G6		772 0432 30
			; G6		772 0458 30
					815 0078 30
		818 0199 10			
		825 0266 10			
		840 0177 10			
		840 0526 10			
		840 0524 10			
		840 0843 10			
		840 0842 10			
2.5 TDI 4motion AXD; BNZ; (96kW)	07.04-11.09	LUK	G6 ; 0A5 ; ID FNN FXW HNC HNE JKT JKU KCK KCM		462 0199 10
			G6 ; 0A5 ; ID KLF		462 0200 10
			incl. O; incl. SAC		600 0125 00
			SAC		624 3156 34
					415 0271 10
					411 0133 11
					512 0366 10
					535 0118 10
					538 0338 10
					428 0040 30
		FAG	BNZ		428 0044 30
			right; →7H...C...000000; 3.200		821 0811 10
			left; →7H...C...000000; 3.200		821 0812 10
			85 mm		713 6107 60
			; G6		771 0476 30
			; G6		772 0432 30
			; G6		772 0458 30
					815 0078 30
					818 0199 10
					825 0266 10
		840 0177 10			
		840 0526 10			
		840 0524 10			
		840 0843 10			
		840 0842 10			
2.5 TDi BLJ; (120kW)	11.03-11.09	LUK	G6 ; 0A5 ; ID GWB GWC HRU HRV JFS JFT KCQ KCR		462 0199 10
			G6 ; 0A5 ; ID KPE		462 0200 10
			incl. O; incl. SAC		600 0215 00
			SAC		624 3178 34
					415 0251 10
					411 0133 11
		512 0366 10			



			<p>SCHAEFFLER</p>
--	--	--	--------------------------

VW

TRANSPORTER T5 (7H_, 7E_)

































































































































<p>2.5 TDi  BLJ; (120kW)</p>	<p>11.03-11.09</p>	<p> FAG</p>	<p> A/C # F-237653.XX  A/C  AXD  right; →7H...C...000000; 3.200  left; →7H...C...000000; 3.200  85 mm  right; MANU  right; G6  right; G6 AUTOM G6  right; MANU  right; G6 AUTOM G6  right; G6  ;  ; 3.000  right  left  right</p>	<p> 535 0118 10  535 0186 10  538 0338 10  428 0040 30  821 0811 10  821 0812 10  Set 713 6107 60  771 0511 30  771 0512 30  771 0476 30  SET 772 0447 30  SET 772 0432 30  SET 772 0458 30  REP 815 0078 30  818 0199 10  825 0266 10  840 0177 10  840 0526 10  840 0524 10  840 0843 10  840 0842 10</p>
<p>2.5 TDi  AXE; BPC; (128kW)</p>	<p>04.03-11.09</p>	<p> FAG</p>	<p>G6; OA5; ID FNQ FXV GWB GWC HRU HRV JFS JFT KCQ KCR GearBOX G6; OA5; ID KPE GearBOX incl. ; incl. ; SAC SAC  A/C # F-237653.XX  A/C  AXE  BPC  right; →7H...C...000000; 3.200  left; →7H...C...000000; 3.200  85 mm  right; G6  right; G6 AUTOM G6  right; AUTOM G6  right; AUTOM G6  right; G6 AUTOM G6  right; G6  ;  ; 3.000  right  left  right  left</p>	<p>462 0199 10 462 0200 10 600 0215 00 624 3178 34 415 0251 10 411 0133 11 512 0366 10 535 0118 10 535 0186 10 538 0338 10 428 0040 30 428 0044 30 821 0811 10 821 0812 10 Set 713 6107 60 771 0512 30 771 0476 30 771 0476 30 SET 772 0432 30 SET 772 0432 30 SET 772 0458 30 REP 815 0078 30 818 0199 10 825 0266 10 840 0177 10 840 0526 10 840 0524 10 840 0843 10 840 0842 10</p>
<p>2.5 TDi 4motion  AXE; BPC; (128kW)</p>	<p>07.04-11.09</p>	<p> FAG</p>	<p>G6; OA5; ID FNN FXW HNC HNE JKT JKU KCK KCM GearBOX G6; OA5; ID KLF GearBOX incl. ; incl. ; SAC SAC  A/C # F-237653.XX  A/C  AXE  BPC</p>	<p>462 0199 10 462 0200 10 600 0215 00 624 3178 34 415 0251 10 411 0133 11 512 0366 10 535 0118 10 535 0186 10 538 0338 10 428 0040 30 428 0044 30</p>



			SCHAEFFLER
--	--	--	-------------------

VW

TRANSPORTER T5 (7H_, 7E_)

<p>2.5 TDI 4motion  AXE; BPC; (128kW)</p>	<p>07.04-11.09</p>	<p>FAG</p>	<p> right;  →7H...C...000000; 3.200</p> <p> left;  →7H...C...000000; 3.200</p> <p> 85 mm</p> <p> ; G6</p> <p> ; G5</p> <p> ; G6</p> <p> ; G5</p> <p> ; G6</p> <p> ; 3.000</p> <p> right</p> <p> left</p> <p> right</p> <p> left</p>	<p> 821 0811 10</p> <p> 821 0812 10</p> <p> Set 713 6107 60</p> <p> 771 0476 30</p> <p> 771 0476 30</p> <p> SET 772 0432 30</p> <p> SET 772 0432 30</p> <p> SET 772 0458 30</p> <p> REP 815 0078 30</p> <p> 818 0199 10</p> <p> 825 0266 10</p> <p> 840 0177 10</p> <p> 840 0526 10</p> <p> 840 0524 10</p> <p> 840 0843 10</p> <p> 840 0842 10</p>
<p>3.2 V6  BDL; (170kW)</p>	<p>04.03-06.05</p>	<p></p> <p>FAG</p>	<p> ;  →7H-4-120 000</p> <p> # F-553470.XX F-227628.XX</p> <p> ; A/C</p> <p>24x</p> <p> 12 mm</p> <p>24x</p> <p>1x</p> <p> right;  →7H...C...000000; 3.200</p> <p> left;  →7H...C...000000; 3.200</p> <p> 85 mm</p> <p> right ; G6</p> <p> ; AUTOM G6</p> <p> ; AUTOM G6</p> <p> ; G6</p> <p> ; 3.000</p> <p> right</p> <p> left</p> <p> right</p> <p> left</p>	<p> 531 0536 10</p> <p> 535 0012 10</p> <p> FB 6PK1264</p> <p> 538 0334 10</p> <p> 420 0172 10</p> <p> 422 0072 10</p> <p> KIT 559 0073 10</p> <p> 821 0811 10</p> <p> 821 0812 10</p> <p> Set 713 6107 60</p> <p> 771 0512 30</p> <p> 771 0476 30</p> <p> SET 772 0432 30</p> <p> SET 772 0458 30</p> <p> REP 815 0078 30</p> <p> 818 0199 10</p> <p> 825 0266 10</p> <p> 840 0177 10</p> <p> 840 0526 10</p> <p> 840 0524 10</p> <p> 840 0843 10</p> <p> 840 0842 10</p>
<p>3.2 V6  BDL; (170kW)</p>	<p>02.04-06.04</p>	<p></p> <p>FAG</p>	<p> ;  →7H-4-120 000</p> <p> # F-553470.XX F-227628.XX</p> <p> ; A/C</p> <p>24x</p> <p> 12 mm</p> <p>24x</p> <p>1x</p> <p> right;  →7H...C...000000; 3.200</p> <p> left;  →7H...C...000000; 3.200</p> <p> 85 mm</p> <p> ; AUTOM G6</p> <p> ; AUTOM G6</p> <p> ; 3.000</p> <p> right</p> <p> left</p> <p> right</p> <p> left</p>	<p> 531 0536 10</p> <p> 535 0012 10</p> <p> FB 6PK1264</p> <p> 538 0334 10</p> <p> 420 0172 10</p> <p> 422 0072 10</p> <p> KIT 559 0073 10</p> <p> 821 0811 10</p> <p> 821 0812 10</p> <p> Set 713 6107 60</p> <p> 771 0476 30</p> <p> SET 772 0432 30</p> <p> REP 815 0078 30</p> <p> 818 0199 10</p> <p> 825 0266 10</p> <p> 840 0177 10</p> <p> 840 0526 10</p> <p> 840 0524 10</p> <p> 840 0843 10</p> <p> 840 0842 10</p>
<p>3.2 4motion 3.2 V6 4motion  BKK; CFLA; (173kW)</p>	<p>11.03-12.09</p>	<p>LUK</p> <p></p>	<p>G6 ;  OA5 ;  ID FQA FXX HND HNF JFW JFX KCL KCN</p> <p>G6 ;  OA5 ;  ID KLG</p> <p> ;  →7H-4-120 000</p> <p> # F-553470.XX F-227628.XX</p> <p> ; A/C</p>	<p>GearBOX 462 0199 10</p> <p>GearBOX 462 0200 10</p> <p> 512 0366 10</p> <p> 531 0536 10</p> <p> 535 0012 10</p> <p> FB 6PK1264</p>



			SCHAEFFLER
--	--	--	-------------------









































VW

TRANSPORTER T5 (7H_, 7E_)

3.2 4motion
3.2 V6 4motion
BKK; CFLA; (173kW)

11.03-12.09

























































24x		538 0334 10
 12 mm		420 0172 10
24x		422 0072 10
1x;  7H-7-000 001→		559 0073 10
 right;  →7H...C...000000; 3.200		821 0811 10
 left;  →7H...C...000000; 3.200		821 0812 10
 		713 6107 60
 85 mm		
  ; G6  AUTOM G6		771 0476 30
  ; G6  AUTOM G6		772 0432 30
		815 0078 30
 ; 		818 0199 10
 ; 3.000		825 0266 10
		840 0177 10
 right		840 0526 10
 left		840 0524 10
 right		840 0843 10
 left		840 0842 10

3.2 V6
BKK; CFLA; (173kW)

02.04-11.09





























 ;  →7H-4-120 000		531 0536 10
 # F-553470.XX F-227628.XX		535 0012 10
 ; A/C		FB 6PK1264
		538 0334 10
24x		420 0172 10
 12 mm		
24x		422 0072 10
1x		553 0310 10
1x;  7H-7-000 001→		553 0310 10
1x;  7H-7-000 001→		559 0073 10
 right;  →7H...C...000000; 3.200		821 0811 10
 left;  →7H...C...000000; 3.200		821 0812 10
 		713 6107 60
 85 mm		
 right  ; G6		771 0512 30
  ;  AUTOM G6		771 0476 30
  ;  AUTOM G6		772 0432 30
		815 0078 30
 ; 		818 0199 10
 ; 3.000		825 0266 10
		840 0177 10
 right		840 0526 10
 left		840 0524 10
 right		840 0843 10
 left		840 0842 10

TRANSPORTER T5 (7J_)

1.9 TDI
BRR; (62kW)

01.06-11.09













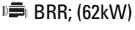





































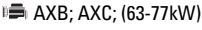









































































































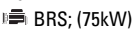

incl.  ; incl.  ; SAC		600 0169 00
 LuK		623 3082 21
SAC; incl. 		
+ 623 3082 00/21		415 0250 10
		411 0133 10
		512 0366 10
		530 0201 10
		530 0201 33
		531 0565 30
		532 0349 10
		534 0151 10
 # F-553470.XX F-227628.XX		535 0012 10
		544 0083 10
		544 0083 20
 ; A/C		FB 6DPK1215
 ; A/C		FB 6PK1138
		538 0054 10
1x		428 0039 30
1x		559 0069 10
right; →7H...C...000000; 3.200		821 0811 10
left; →7H...C...000000; 3.200		821 0812 10
		713 6107 60
85 mm		



			SCHAEFFLER
--	---	--	-------------------

VW

TRANSPORTER T5 (7J_)





























































































































































































<p>1.9 TDI  BRR; (62kW)</p>	<p>01.06-11.09</p>	<p>FAG</p>	 right  MANU  771 0511 30			
			 left  G5  771 0419 30			
			 108 mm  771 0477 30			
			 right  MANU  SET  772 0447 30			
			 right  G5  SET  772 0457 30			
			 right  G5  SET  772 0431 30			
			  REP  815 0078 30			
			  818 0199 10			
			 ; 3.000  825 0266 10			
			  840 0177 10			
			 right  840 0526 10			
			 left  840 0524 10			
			 right  840 0843 10			
			 left  840 0842 10			
			<p>1.9 TDI  AXB; AXC; (63-77kW)</p>	<p>04.03-11.09</p>	<p>LUK</p>	<p>incl.  ; incl.  SAC  600 0169 00</p>
						<p> LuK  623 3082 21</p>
						<p>SAC; incl.   415 0250 10</p>
						<p>  411 0133 10</p>
						<p>  512 0366 10</p>
						<p>  530 0201 10</p>
<p>  530 0201 33</p>						
<p>  531 0565 30</p>						
<p>  532 0349 10</p>						
<p>  534 0132 30</p>						
<p>  534 0151 10</p>						
<p> # F-553470.XX F-227628.XX  535 0012 10</p>						
<p> 7J-3-000 001 →  7J-5-022 000  544 0065 10</p>						
<p> 7H-5H081 001 →  544 0083 10</p>						
<p> 7H-5X022 401 →  544 0083 20</p>						
<p> 7H-5H081 001 →  544 0083 20</p>						
<p> 7H-5X022 401 →  544 0083 20</p>						
<p>  → 7H-6H079 890 7H-6X022 356; A/C  FB 6DPK1195</p>						
<p>  → 7H-6H079 891 →; A/C  FB 6DPK1215</p>						
<p>  → 7H-6X022 357 →; A/C  FB 6PK1120</p>						
<p>  → 7H-6H079 890; A/C  FB 6PK1120</p>						
<p>  → 7H-6X022 356; A/C  FB 6PK1138</p>						
<p>  → 7H-6H079 891 →; A/C  FB 6PK1138</p>						
<p>  → 7H-6X022 357 →; A/C  538 0054 10</p>						
<p>1x  428 0042 30</p>						
<p>1x  KIT OILP  559 0069 10</p>						
<p>FAG</p>	<p> right;  MANU → 7H...C...000000; 3.200  821 0811 10</p>					
	<p> left;  MANU → 7H...C...000000; 3.200  821 0812 10</p>					
	<p>  Set  713 6107 60</p>					
	<p> right  MANU  771 0511 30</p>					
	<p> left  G5  771 0419 30</p>					
	<p> 108 mm  771 0477 30</p>					
	<p> right  MANU  SET  772 0447 30</p>					
	<p> right  G5  SET  772 0457 30</p>					
	<p> right  G5  SET  772 0431 30</p>					
	<p>  REP  815 0078 30</p>					
	<p>  818 0199 10</p>					
	<p> ; 3.000  825 0266 10</p>					
	<p>  840 0177 10</p>					
	<p> right  840 0526 10</p>					
	<p> left  840 0524 10</p>					
	<p> right  840 0843 10</p>					
	<p> left  840 0842 10</p>					
	<p>1.9 TDI  BRS; (75kW)</p>	<p>06.06-11.09</p>	<p>LUK</p>	<p>incl.  ; incl.  SAC  600 0169 00</p>		
				<p> LuK  623 3082 21</p>		
				<p>SAC; incl.   415 0250 10</p>		
<p>  411 0133 10</p>						
<p>  512 0366 10</p>						



			<p>SCHAEFFLER</p>
--	--	--	--------------------------

VW

TRANSPORTER T5 (7J_)











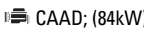





















































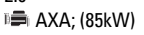

























































<p>1.9 TDI BRS; (75kW)</p>	<p>06.06-11.09</p>		<table border="1"> <tr><td></td><td></td><td>530 0201 10</td></tr> <tr><td></td><td></td><td>530 0201 33</td></tr> <tr><td></td><td></td><td>531 0565 30</td></tr> <tr><td></td><td></td><td>532 0349 10</td></tr> <tr><td></td><td></td><td>534 0151 10</td></tr> <tr><td></td><td></td><td>535 0012 10</td></tr> <tr><td></td><td></td><td>544 0083 10</td></tr> <tr><td></td><td></td><td>544 0083 20</td></tr> <tr><td></td><td></td><td>FB 6DPK1215</td></tr> <tr><td></td><td></td><td>FB 6PK1138</td></tr> <tr><td></td><td></td><td>538 0054 10</td></tr> <tr><td></td><td></td><td>428 0039 30</td></tr> <tr><td></td><td></td><td>559 0069 10</td></tr> <tr><td></td><td></td><td>821 0811 10</td></tr> <tr><td></td><td></td><td>821 0812 10</td></tr> <tr><td></td><td></td><td>713 6107 60</td></tr> <tr><td></td><td></td><td>85 mm</td></tr> <tr><td></td><td></td><td>right MANU</td></tr> <tr><td></td><td></td><td>left G5</td></tr> <tr><td></td><td></td><td>108 mm</td></tr> <tr><td></td><td></td><td>G5</td></tr> <tr><td></td><td></td><td>right MANU</td></tr> <tr><td></td><td></td><td>right G5</td></tr> <tr><td></td><td></td><td>G5</td></tr> <tr><td></td><td></td><td>G5</td></tr> <tr><td></td><td></td><td>REP</td></tr> <tr><td></td><td></td><td>815 0078 30</td></tr> <tr><td></td><td></td><td>818 0199 10</td></tr> <tr><td></td><td></td><td>3.000</td></tr> <tr><td></td><td></td><td>825 0266 10</td></tr> <tr><td></td><td></td><td>840 0177 10</td></tr> <tr><td></td><td></td><td>right</td></tr> <tr><td></td><td></td><td>left</td></tr> </table>			530 0201 10			530 0201 33			531 0565 30			532 0349 10			534 0151 10			535 0012 10			544 0083 10			544 0083 20			FB 6DPK1215			FB 6PK1138			538 0054 10			428 0039 30			559 0069 10			821 0811 10			821 0812 10			713 6107 60			85 mm			right MANU			left G5			108 mm			G5			right MANU			right G5			G5			G5			REP			815 0078 30			818 0199 10			3.000			825 0266 10			840 0177 10			right			left																																														
		530 0201 10																																																																																																																																																		
		530 0201 33																																																																																																																																																		
		531 0565 30																																																																																																																																																		
		532 0349 10																																																																																																																																																		
		534 0151 10																																																																																																																																																		
		535 0012 10																																																																																																																																																		
		544 0083 10																																																																																																																																																		
		544 0083 20																																																																																																																																																		
		FB 6DPK1215																																																																																																																																																		
		FB 6PK1138																																																																																																																																																		
		538 0054 10																																																																																																																																																		
		428 0039 30																																																																																																																																																		
		559 0069 10																																																																																																																																																		
		821 0811 10																																																																																																																																																		
		821 0812 10																																																																																																																																																		
		713 6107 60																																																																																																																																																		
		85 mm																																																																																																																																																		
		right MANU																																																																																																																																																		
		left G5																																																																																																																																																		
		108 mm																																																																																																																																																		
		G5																																																																																																																																																		
		right MANU																																																																																																																																																		
		right G5																																																																																																																																																		
		G5																																																																																																																																																		
		G5																																																																																																																																																		
		REP																																																																																																																																																		
		815 0078 30																																																																																																																																																		
		818 0199 10																																																																																																																																																		
		3.000																																																																																																																																																		
		825 0266 10																																																																																																																																																		
		840 0177 10																																																																																																																																																		
		right																																																																																																																																																		
		left																																																																																																																																																		
<p>2.0 TDI CAAA; CAAB; (62-75kW)</p>	<p>09.09-08.15</p>		<table border="1"> <tr><td></td><td></td><td>SAC; incl. START/STOP</td><td>623 3082 21</td></tr> <tr><td></td><td></td><td>C#000001 →; START/STOP</td><td>415 0557 10</td></tr> <tr><td></td><td></td><td>→B#500000</td><td>415 0574 10</td></tr> <tr><td></td><td></td><td>C#000001 →; START/STOP</td><td>411 0133 10</td></tr> <tr><td></td><td></td><td></td><td>512 0366 10</td></tr> <tr><td></td><td></td><td></td><td>530 0550 10</td></tr> <tr><td></td><td></td><td></td><td>530 0550 32</td></tr> <tr><td></td><td></td><td></td><td>531 0825 10</td></tr> <tr><td></td><td></td><td></td><td>532 0161 10</td></tr> <tr><td></td><td></td><td></td><td>532 0582 10</td></tr> <tr><td></td><td></td><td></td><td>532 0623 10</td></tr> <tr><td></td><td></td><td>+ A/C</td><td>529 0240 10</td></tr> <tr><td></td><td></td><td></td><td>532 0468 10</td></tr> <tr><td></td><td></td><td></td><td>534 0164 10</td></tr> <tr><td></td><td></td><td>F# F-551406.XX</td><td>535 0124 10</td></tr> <tr><td></td><td></td><td>A/C</td><td>FB 6PK1078</td></tr> <tr><td></td><td></td><td>A/C</td><td>FB 6PK1555</td></tr> <tr><td></td><td></td><td></td><td>538 0060 10</td></tr> <tr><td></td><td></td><td>16x</td><td>420 0222 10</td></tr> <tr><td></td><td></td><td>12 mm</td><td></td></tr> <tr><td></td><td></td><td>16x</td><td>422 0102 10</td></tr> <tr><td></td><td></td><td>right →7H...C...000000; 3.200</td><td>821 0811 10</td></tr> <tr><td></td><td></td><td>left →7H...C...000000; 3.200</td><td>821 0812 10</td></tr> <tr><td></td><td></td><td></td><td>713 6107 60</td></tr> <tr><td></td><td></td><td>85 mm</td><td></td></tr> <tr><td></td><td></td><td>left →12.10; G5</td><td>771 0419 30</td></tr> <tr><td></td><td></td><td>108 mm</td><td></td></tr> <tr><td></td><td></td><td>04.10 →; G5</td><td>771 0477 30</td></tr> <tr><td></td><td></td><td>right G5</td><td>SET 772 0457 30</td></tr> <tr><td></td><td></td><td>04.10 →; G5</td><td>SET 772 0431 30</td></tr> <tr><td></td><td></td><td></td><td>REP 815 0078 30</td></tr> <tr><td></td><td></td><td></td><td>818 0199 10</td></tr> <tr><td></td><td></td><td>3.000</td><td>825 0266 10</td></tr> <tr><td></td><td></td><td></td><td>840 0177 10</td></tr> <tr><td></td><td></td><td>right</td><td>840 0843 10</td></tr> <tr><td></td><td></td><td>left</td><td>840 0842 10</td></tr> </table>			SAC; incl. START/STOP	623 3082 21			C#000001 →; START/STOP	415 0557 10			→B#500000	415 0574 10			C#000001 →; START/STOP	411 0133 10				512 0366 10				530 0550 10				530 0550 32				531 0825 10				532 0161 10				532 0582 10				532 0623 10			+ A/C	529 0240 10				532 0468 10				534 0164 10			F# F-551406.XX	535 0124 10			A/C	FB 6PK1078			A/C	FB 6PK1555				538 0060 10			16x	420 0222 10			12 mm				16x	422 0102 10			right →7H...C...000000; 3.200	821 0811 10			left →7H...C...000000; 3.200	821 0812 10				713 6107 60			85 mm				left →12.10; G5	771 0419 30			108 mm				04.10 →; G5	771 0477 30			right G5	SET 772 0457 30			04.10 →; G5	SET 772 0431 30				REP 815 0078 30				818 0199 10			3.000	825 0266 10				840 0177 10			right	840 0843 10			left	840 0842 10	
		SAC; incl. START/STOP	623 3082 21																																																																																																																																																	
		C#000001 →; START/STOP	415 0557 10																																																																																																																																																	
		→B#500000	415 0574 10																																																																																																																																																	
		C#000001 →; START/STOP	411 0133 10																																																																																																																																																	
			512 0366 10																																																																																																																																																	
			530 0550 10																																																																																																																																																	
			530 0550 32																																																																																																																																																	
			531 0825 10																																																																																																																																																	
			532 0161 10																																																																																																																																																	
			532 0582 10																																																																																																																																																	
			532 0623 10																																																																																																																																																	
		+ A/C	529 0240 10																																																																																																																																																	
			532 0468 10																																																																																																																																																	
			534 0164 10																																																																																																																																																	
		F# F-551406.XX	535 0124 10																																																																																																																																																	
		A/C	FB 6PK1078																																																																																																																																																	
		A/C	FB 6PK1555																																																																																																																																																	
			538 0060 10																																																																																																																																																	
		16x	420 0222 10																																																																																																																																																	
		12 mm																																																																																																																																																		
		16x	422 0102 10																																																																																																																																																	
		right →7H...C...000000; 3.200	821 0811 10																																																																																																																																																	
		left →7H...C...000000; 3.200	821 0812 10																																																																																																																																																	
			713 6107 60																																																																																																																																																	
		85 mm																																																																																																																																																		
		left →12.10; G5	771 0419 30																																																																																																																																																	
		108 mm																																																																																																																																																		
		04.10 →; G5	771 0477 30																																																																																																																																																	
		right G5	SET 772 0457 30																																																																																																																																																	
		04.10 →; G5	SET 772 0431 30																																																																																																																																																	
			REP 815 0078 30																																																																																																																																																	
			818 0199 10																																																																																																																																																	
		3.000	825 0266 10																																																																																																																																																	
			840 0177 10																																																																																																																																																	
		right	840 0843 10																																																																																																																																																	
		left	840 0842 10																																																																																																																																																	
<p>2.0 TDI CAAD; (84kW)</p>	<p>05.11-08.15</p>		<table border="1"> <tr><td></td><td></td><td>SAC; incl. START/STOP</td><td>623 3082 21</td></tr> <tr><td></td><td></td><td>START/STOP</td><td>415 0557 10</td></tr> </table>			SAC; incl. START/STOP	623 3082 21			START/STOP	415 0557 10																																																																																																																																									
		SAC; incl. START/STOP	623 3082 21																																																																																																																																																	
		START/STOP	415 0557 10																																																																																																																																																	

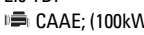

			SCHAEFFLER
--	---	--	-------------------

VW

TRANSPORTER T5 (7J_)

2.0 TDI  CAAD; (84kW)	05.11-08.15		START/STOP		415 0574 10			
					411 0133 10			
					512 0366 10			
					530 0550 10			
					530 0550 32			
					531 0825 10			
					532 0161 10			
					532 0582 10			
					532 0623 10			
					529 0240 10			
				532 0468 10				
				534 0164 10				
				535 0124 10				
				FB 6PK1078				
				FB 6PK1555				
				538 0060 10				
				420 0222 10				
		16x  12 mm 16x	05.11-08.15		 right;  →7H...C...000000; 3.200		821 0811 10	
					 left;  →7H...C...000000; 3.200		821 0812 10	
					 		713 6107 60	
  85 mm					771 0477 30			
  ; →06.13; G5					772 0457 30			
 right  ; 					772 0431 30			
  ; →06.13; G5					815 0078 30			
					818 0199 10			
 ; 					825 0266 10			
 ; 3.000					840 0177 10			
 right					840 0843 10			
 left					840 0842 10			
					623 3160 00			
2.0  AXA; (85kW)	11.03-05.13							512 0366 10
								530 0171 10
				530 0171 31				
				531 0203 20				
				533 0076 30				
				535 0012 10				
				544 0003 10				
				FB 6DPK1195				
				FB 6PK1120				
				538 0038 10				
				420 0043 10				
				559 0067 10				
		8x  35 mm 1x	11.03-05.13		 right;  →7H...C...000000; 3.200		821 0811 10	
					 left;  →7H...C...000000; 3.200		821 0812 10	
					 		713 6107 60	
  85 mm					771 0511 30			
 right  ; 					771 0419 30			
 left  ; G5					771 0477 30			
  ; G5					772 0447 30			
 right  ; 					772 0457 30			
 right  ; G5					772 0431 30			
  ; G5					815 0078 30			
		818 0199 10						
 ; 		825 0266 10						
 ; 3.000		840 0177 10						
		840 0526 10						
 right		840 0524 10						
 left		840 0843 10						
 right		840 0842 10						
left		840 0842 10						
2.0 TDI  CAAE; (100kW)	05.10-08.15		→05.12;  135		600 0321 00			
			06.12→; START/STOP;  135 incl.  ; incl.  ; SAC					



			SCHAEFFLER
--	--	--	-------------------

VW

TRANSPORTER T5 (7J_)

2.0 TDI
 CAAE; (100kW)

05.10-08.15

	DSP		602 0018 00
	SDG		624 3517 33
	SAC		415 0540 10
	→05.12; 135		415 0615 09
	06.12→; START/STOP ; 135		415 0734 10
			411 0133 10
	incl.		512 0366 10
	06.12→; START/STOP ; 132		530 0550 10
			530 0550 32
			531 0825 10
			532 0161 10
			532 0582 10
			532 0623 10
			532 0468 10
			534 0164 10
	# F-551406.XX		535 0124 10
			538 0060 10
	16x ⌀ 12 mm		420 0222 10
	16x		422 0102 10
	FAG →7H...C...000000; 3.200		821 0811 10
←7H...C...000000; 3.200		821 0812 10	
 ⌀ 85 mm		713 6107 60	
→06.13; G6 G7		771 0476 30	
→07.13; G5		771 0477 30	
→07.13; G5		772 0431 30	
→06.13; G6 G7		772 0432 30	
; G6		772 0458 30	
		815 0078 30	
		818 0199 10	
; 3.000		825 0266 10	
		840 0177 10	
right		840 0843 10	
left		840 0842 10	

2.0 TDI 4motion
 CAAE; CCHB; (100kW)

05.10-08.15



















































	→05.12; 135		600 0321 00
	06.12→; START/STOP ; 135		624 3517 33
	incl. ; ; SAC		415 0540 10
			415 0734 10
	SAC		411 0133 10
	→05.12; 135		512 0366 10
	06.12→; START/STOP ; 135		530 0550 10
	06.12→; START/STOP ; 132		530 0550 32
			531 0825 10
			532 0161 10
			532 0582 10
			532 0623 10
			532 0468 10
			534 0164 10
	# F-551406.XX		535 0124 10
			538 0060 10
	16x ⌀ 12 mm		420 0222 10
	16x		422 0102 10
	FAG →7H...C...000000; 3.200		821 0811 10
	←7H...C...000000; 3.200		821 0812 10
 ⌀ 85 mm		713 6107 60	
→06.13; G6 G7		771 0476 30	
→06.13; G6 G7		772 0432 30	
; G6		772 0458 30	
		815 0078 30	
		818 0199 10	



			SCHAEFFLER
--	---	--	-------------------

VW

TRANSPORTER T5 (7J_)





2.0 TDI 4motion CAAE; CCHB; (100kW)	05.10-08.15	FAG	↳ ; 3.000		825 0266 10
			↳ right		840 0177 10
2.0 TDI CAAC; CCHA; (103kW)	09.09-08.15	LUK	G6 ; ↳ OA5 ; ↳ ID KUP PAP PAQ PAU	GearBOX	462 0200 10
			→05.12; ↳ 135		600 0321 00
			06.12→; START/STOP ; ↳ 135		
			incl. ⓪; incl. ↳; SAC		
			↳ DSG ; ↳ ID PSP		602 0018 00
			↳ DSG ; ↳ ID SDG		
			SAC		624 3517 33
			→05.12; ↳ 135		415 0540 10
			06.12→; START/STOP ; ↳ 135		
			02.10→; ↳ DSG		415 0615 09
			EURO 5 ; 06.10→; ↳ DSG		
			incl. ↳		
			→01.10; ↳ DSG		415 0618 09
			EURO 5 ; →05.10; ↳ DSG		
			incl. ↳		
			06.12→; START/STOP ; ↳ 132		415 0734 10
			↳ MANU		411 0133 10
					512 0366 10
					530 0550 10
					530 0550 32
					531 0825 10
					532 0161 10
					532 0582 10
					532 0623 10
			↳ ; + ⓪ ; A/C		529 0240 10
			↳		532 0468 10
			↳		534 0164 10
			↳# F-551406.XX		535 0124 10
↳ ; A/C		FB 6PK1078			
↳ ; A/C		FB 6PK1555			
16x		538 0060 10			
⓪ 12 mm		420 0222 10			
16x		422 0102 10			
FAG	↳ right; ↳ →7H...C...000000; 3.200		821 0811 10		
	↳ left; ↳ →7H...C...000000; 3.200		821 0812 10		
	↳		Set 713 6107 60		
	⓪ 85 mm				
	↳ left ↳ ← ; →12.10; G5		771 0419 30		
	⓪ 108 mm				
	↳ ↳ ; G6 G7		771 0476 30		
	↳ ↳ ; 04.10→; G5		771 0477 30		
	↳ right ↳ ← ; G5		SET 772 0457 30		
	↳ ↳ ; 04.10→; G5		SET 772 0431 30		
	↳ ↳ ; G6 G7		SET 772 0432 30		
	↳ ↳ ← ; G6		SET 772 0458 30		
	↳		REP 815 0078 30		
	↳ ; ↳		818 0199 10		
	↳ ; 3.000		825 0266 10		
	↳		840 0177 10		
	↳ right		840 0843 10		
	↳ left		840 0842 10		
2.0 TDI 4motion CAAC; CCHA; (103kW)	09.09-08.15	LUK	G6 ; ↳ OA5 ; ↳ ID KQK PAQ PAR PAW	GearBOX	462 0200 10
			→05.12; ↳ 135		600 0321 00
			06.12→; START/STOP ; ↳ 135		
			incl. ⓪; incl. ↳; SAC		
			SAC		624 3517 33
			→05.12; ↳ 135		415 0540 10
			06.12→; START/STOP ; ↳ 135		
			06.12→; START/STOP ; ↳ 132		415 0734 10
					411 0133 10
					512 0366 10
					530 0550 10
					530 0550 32
		531 0825 10			



			<p>SCHAEFFLER</p>
--	--	--	--------------------------

VW

TRANSPORTER T5 (7J_)











































































































<p>2.0 TDI 4motion CAAC; CCHA; (103kW)</p>	<p>09.09-08.15</p>		<p>16x 12 mm</p> <p>16x</p> <p>FAG right; →7H...C...000000; 3.200 left; →7H...C...000000; 3.200</p> <p>85 mm</p> <p>→06.13; G6 G7 →06.13; G6 G7 →G6</p> <p>right left</p>	<p>532 0161 10 532 0582 10 532 0623 10 529 0240 10 532 0468 10 534 0164 10 535 0124 10 FB 6PK1078 FB 6PK1555 538 0060 10 420 0222 10 422 0102 10 821 0811 10 821 0812 10 Set 713 6107 60 771 0476 30 SET 772 0432 30 SET 772 0458 30 REP 815 0078 30 818 0199 10 825 0266 10 840 0177 10 840 0843 10 840 0842 10</p>
<p>2.0 TSI CJKB; (110kW)</p>	<p>07.12-08.15</p>	 	<p>G6; OA5; ID PAV</p> <p>1000555 1013776 920851</p> <p>16x 12 mm</p> <p>8x; 1x 1x 1x 1x</p> <p>FAG right; →7H...C...000000; 3.200 left; →7H...C...000000; 3.200</p> <p>85 mm</p> <p>→06.13; G6 G7 →06.13; G6 G7 →G6</p> <p>right left</p>	<p>GearBOX 462 0200 10 512 0366 10 532 0694 10 534 0333 10 535 0210 10 420 0224 10 422 0058 10 427 0016 10 OILP 553 0388 10 KIT 559 0196 10 711 0294 10 821 0811 10 821 0812 10 Set 713 6107 60 771 0476 30 SET 772 0432 30 SET 772 0458 30 REP 815 0078 30 818 0199 10 825 0266 10 840 0177 10 840 0843 10 840 0842 10</p>
<p>2.0 BiTDI CFCA; (132kW)</p>	<p>09.09-08.15</p>	 	<p>G6; OA5; ID KUP MKB NTF PAT DSG; ID PSP DSG; ID SDG</p> <p>SAC DSG incl. START/STOP MANU</p>	<p>GearBOX 462 0200 10 602 0018 00 624 3783 33 415 0618 09 415 0853 10 411 0133 10 512 0366 10 530 0550 10 530 0550 32 531 0825 10 532 0161 10 532 0582 10 532 0623 10 529 0240 10 532 0468 10 534 0164 10</p>



			SCHAEFFLER
--	--	--	-------------------

VW

TRANSPORTER T5 (7J_)





























































































2.0 BitDI CFCA; (132kW)	09.09-08.15		# F-551406.XX	 535 0124 10
			 ; A/C	 FB 6PK1078
			 ; A/C	 FB 6PK1555
			16x	 538 0060 10
			 12 mm	 420 0222 10
			16x	 422 0102 10
			FAG  right; →7H...C...000000; 3.200	 821 0811 10
			FAG  left; →7H...C...000000; 3.200	 821 0812 10
			 85 mm	 Set 713 6107 60
			 left; →12.10; G5	 771 0419 30
		 108 mm	 771 0477 30	
		 ; 04.10 →; G5	 SET 772 0431 30	
		 ; 04.10 →; G5	 SET 772 0457 30	
		 right; G5	 REP 815 0078 30	
		 ;	 818 0199 10	
		 ; 3.000	 825 0266 10	
			 840 0177 10	
		 right	 840 0843 10	
		 left	 840 0842 10	
		2.0 BitDI 4motion CFCA; (132kW)	09.09-08.15	
 DSG;  ID PSR	 602 0018 00			
 DSG;  ID SDD	 624 3783 33			
SAC	 415 0618 09			
 DSG	 415 0853 10			
incl. 	 411 0133 10			
START/STOP	 512 0366 10			
 MANU	 530 0550 10			
	 530 0550 32			
	 531 0825 10			
	 532 0161 10			
	 532 0582 10			
	 532 0623 10			
	 529 0240 10			
	 532 0468 10			
	 534 0164 10			
# F-551406.XX	 535 0124 10			
 ; A/C	 FB 6PK1078			
 ; A/C	 FB 6PK1555			
16x	 538 0060 10			
 12 mm	 420 0222 10			
16x	 422 0102 10			
FAG  right; →7H...C...000000; 3.200	 821 0811 10			
FAG  left; →7H...C...000000; 3.200	 821 0812 10			
 85 mm	 Set 713 6107 60			
 ; →06.13; G6 G7	 771 0476 30			
 ; →06.13; G6 G7	 SET 772 0432 30			
 ; G6	 SET 772 0458 30			
	 REP 815 0078 30			
 ;	 818 0199 10			
 ; 3.000	 825 0266 10			
	 840 0177 10			
 right	 840 0843 10			
 left	 840 0842 10			
2.5 TDI AXD; BNZ; (96kW)	04.03-11.09		G6 ;  0A5;  ID FNQ FXV GWB GWC HRU HRV JFS JFT KCQ KCR	GearBOX 462 0199 10
			G6 ;  0A5;  ID KPE	GearBOX 462 0200 10
			incl.  ; incl. ; SAC	 600 0125 00
			SAC	624 3156 34
				415 0271 10
				411 0133 11
	512 0366 10			



			SCHAEFFLER
--	--	--	-------------------

VW

TRANSPORTER T5 (7J_)

2.5 TDI AXD; BNZ; (96kW)	04.03-11.09	 FAG	 A/C  # F-237653.XX  A/C	 535 0118 10  535 0186 10  538 0338 10  428 0040 30  428 0044 30		
			 right; →7H...C...000000; 3.200  left; →7H...C...000000; 3.200  85 mm  right; G6  G6 AUTOM G6  G6 AUTOM G6  G6  REP  3.000  right  left  right  left	 821 0811 10  821 0812 10  Set 713 6107 60  771 0512 30  771 0476 30  SET 772 0432 30  SET 772 0458 30  815 0078 30  818 0199 10  825 0266 10  840 0177 10  840 0526 10  840 0524 10  840 0843 10  840 0842 10		
			 FAG	G6; ID 0A5; ID FNN FXW HNC HNE JKT JKU KCK KCM G6; ID 0A5; ID KLF incl. ○; incl. SAC SAC	GearBOX 462 0199 10 GearBOX 462 0200 10  600 0125 00  624 3156 34  415 0271 10  411 0133 11  512 0366 10  535 0118 10  535 0186 10  538 0338 10  428 0040 30  428 0044 30	
				 right; →7H...C...000000; 3.200  left; →7H...C...000000; 3.200  85 mm  right; G6  G6  G6  G6  REP  3.000  right  left  right  left	 821 0811 10  821 0812 10  Set 713 6107 60  771 0476 30  SET 772 0432 30  SET 772 0458 30  815 0078 30  818 0199 10  825 0266 10  840 0177 10  840 0526 10  840 0524 10  840 0843 10  840 0842 10	
				 FAG	G6; ID 0A5; ID FNQ FXV GWB GWC HRU HRV JFS JFT KCQ KCR G6; ID 0A5; ID KPE incl. ○; incl. SAC SAC	GearBOX 462 0199 10 GearBOX 462 0200 10  600 0215 00  624 3178 34  415 0251 10  411 0133 11  512 0366 10  535 0118 10  535 0186 10  538 0338 10  428 0040 30  428 0044 30
					 right; →7H...C...000000; 3.200  left; →7H...C...000000; 3.200  85 mm	 821 0811 10  821 0812 10  Set 713 6107 60



			SCHAEFFLER
--	---	--	-------------------

VW

TRANSPORTER T5 (7J_)





















































































2.5 TDI AXE; BPC; (128kW)	04.03-11.09	FAG	right ; G6		771 0512 30
			; G5 AUTOM G6		771 0476 30
			; G5 AUTOM G6		772 0432 30
			; G6		772 0458 30
					815 0078 30
					818 0199 10
			; 3.000		825 0266 10
					840 0177 10
			right		840 0526 10
			left		840 0524 10
			right		840 0843 10
			left		840 0842 10
					462 0199 10
					462 0200 10
			2.5 TDI 4motion AXE; BPC; (128kW)	04.04-11.09	LUK
G6; OA5; ID KLF		GearBOX			
incl. ; incl. ; SAC		600 0215 00			
SAC		624 3178 34			
		415 0251 10			
		411 0133 11			
		512 0366 10			
	A/C				535 0118 10
	# F-237653.XX				
	A/C				535 0186 10
	AXE				538 0338 10
	BPC				428 0040 30
					428 0044 30
FAG	right; →7H...C...000000; 3.200				821 0811 10
	left; →7H...C...000000; 3.200				821 0812 10
			713 6107 60		
	85 mm				
	; G6		771 0476 30		
	; G6		772 0432 30		
	; G6		772 0458 30		
			815 0078 30		
			818 0199 10		
	; 3.000		825 0266 10		
			840 0177 10		
	right		840 0843 10		
	left		840 0842 10		
			512 0366 10		
	3.2 4motion BDL; (170kW)	11.03-11.09	LUK	; →7H-4-120 000	
# F-553470.XX F-227628.XX					535 0012 10
					538 0334 10
24x				420 0172 10	
12 mm					
24x				422 0072 10	
1x				559 0073 10	
FAG			right; →7H...C...000000; 3.200		821 0811 10
			left; →7H...C...000000; 3.200		821 0812 10
					713 6107 60
			85 mm		
			↑up		814 0155 10
					814 0154 10
			; + 814 0188 10 713 0425 20		814 0187 10
			153 mm		
	; + 814 0187 10 713 0425 20		814 0188 10		
	160 mm				
			818 0199 10		
	; 3.000		825 0266 10		
			840 0177 10		
	right		840 0526 10		
	left		840 0524 10		
right		840 0843 10			
left		840 0842 10			
3.2 V6 BDL; (170kW)	02.04-11.09		; →7H-4-120 000		531 0536 10
			# F-553470.XX F-227628.XX		535 0012 10
			; A/C		FB 6PK1264
					538 0334 10























































			SCHAEFFLER
--	--	--	-------------------

VW

TRANSPORTER T5 (7J_)

3.2 V6 BDL; (170kW)	02.04-11.09		24x  12 mm		420 0172 10
		FAG	24x 1x		422 0072 10
 right;  →7H...C...000000; 3.200			559 0073 10		
 left;  →7H...C...000000; 3.200			821 0811 10		
 			821 0812 10		
 85 mm			Set 713 6107 60		
  AUTOM G6			771 0476 30		
  AUTOM G6			SET 772 0432 30		
			REP 815 0078 30		
 ; 			818 0199 10		
 ; 3.000			825 0266 10		
			840 0177 10		
 right			840 0526 10		
 left			840 0524 10		
 right		840 0843 10			
 left		840 0842 10			
3.2 V6 BKK; (173kW)	08.03-05.06			512 0366 10	
FAG			 ;  →7H-4-120 000		531 0536 10
	 # F-553470.XX F-227628.XX		535 0012 10		
	 ; A/C		FB 6PK1264		
			538 0334 10		
	24x  12 mm		420 0172 10		
	24x		422 0072 10		
	 right;  →7H...C...000000; 3.200		821 0811 10		
	 left;  →7H...C...000000; 3.200		821 0812 10		
	 		Set 713 6107 60		
	 85 mm		771 0476 30		
	  AUTOM G6		772 0432 30		
	  AUTOM G6		REP 815 0078 30		
			818 0199 10		
	 ; 3.000		825 0266 10		
			840 0177 10		
	 right		840 0526 10		
	 left		840 0524 10		
	 right		840 0843 10		
	 left		840 0842 10		

TRANSPORTER T6 (SFD, SFE, SFL, SFZ)











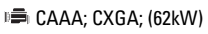













































































































2.0 TDI CAAA; CXGA; (62kW)	04.15-06.16		SAC		623 3765 00
		FAG	START/STOP		415 0557 10
START/STOP			415 0574 10		
			411 0133 10		
			530 0550 10		
			530 0550 32		
			531 0825 10		
			532 0161 10		
			532 0582 10		
			532 0623 10		
 ; +  ; A/C			529 0240 10		
			532 0468 10		
 ; CAAA			534 0164 10		
 # F-551406.XX			535 0124 10		
 ; CAAA; A/C			FB 6PK1078		
 ; CXGA; A/C			FB 6PK1090		
 ; A/C			FB 6PK1555		
			538 0060 10		
 CXGA			538 0807 10		
16x  12 mm		420 0222 10			
16x; CAAA		422 0102 10			
 		Set 713 0079 20			
 85 mm		713 6107 60			
 right  ;  7J...G...000001 →; G5		SET 772 0457 30			
  ; G6		SET 772 0458 30			



			SCHAEFFLER
--	--	--	-------------------

VW

TRANSPORTER T6 (SFD, SFE, SFL, SFZ)

2.0 TDI 	04.15-06.16	FAG			814 0187 10
			 153 mm		814 0188 10
			 160 mm		818 0199 10
			 ; 3.000		825 0266 10
					840 0177 10
			 right		840 0843 10
			 left		840 0842 10
			LUK		623 3765 00
			SAC		415 0557 10
			START/STOP		415 0574 10
					411 0133 10
					530 0550 10
					530 0550 32
					531 0825 10
		532 0161 10			
		532 0582 10			
		532 0623 10			
 ; +  ; A/C		529 0240 10			
		532 0468 10			
 ;  CAAB		534 0164 10			
 # F-551406.XX		535 0124 10			
 ;  CAAB; A/C		FB 6PK1078			
 ;  CXGB; A/C		FB 6PK1090			
 ; A/C		FB 6PK1555			
		538 0060 10			
 ;  CXGB; → 11.16		538 0733 10			
11.16 → ;  CXGB		538 0807 10			
16x		420 0222 10			
 12 mm		422 0102 10			
16x;  CAAB		713 0079 20			
FAG		713 6107 60			
		772 0457 30			
 85 mm		814 0187 10			
 right  ;  →; G5 ; PR. M0H G0J		814 0187 10			
 153 mm		814 0188 10			
 160 mm		818 0199 10			
 ; 3.000		825 0266 10			
		840 0177 10			
 right		840 0843 10			
 left		840 0842 10			
LUK		623 3765 00			
SAC		415 0557 10			
		411 0133 10			
		532 0161 10			
		532 0623 10			
		532 0468 10			
 # F-551406.XX		535 0124 10			
 ;  CXGC; A/C		FB 6PK1090			
 ; A/C		FB 6PK1555			
11.16 →		538 0807 10			
16x		420 0222 10			
 12 mm		713 0079 20			
FAG		772 0457 30			
 right  ;  →; G5		814 0187 10			
 153 mm		814 0188 10			
 160 mm		818 0199 10			
 ; 3.000		825 0266 10			
		840 0177 10			
 right		840 0843 10			
 left		840 0842 10			































































			<p>SCHAEFFLER</p>
--	--	--	--------------------------

VW

TRANSPORTER T6 (SFD, SFE, SFL, SFZ)

















































2.0 TDI
CAAC; (103kW)

04.15-

		G6 ;  OA5 ;  RLF RLH	GearBOX	462 0235 10
		 DSG ;  PSP		602 0018 00
		 DSG ;  SDG		
		SAC		624 3517 33
		 DSG		415 0615 09
		incl. 		
				415 0734 10
		 MANU		411 0133 10
				530 0550 10
				530 0550 32
				531 0825 10
				532 0161 10
				532 0582 10
				532 0623 10
		 ; +  ; A/C		529 0240 10
				532 0468 10
				534 0164 10
		## F-551406.XX		535 0124 10
		 ; A/C		FB 6PK1078
		 ; A/C		FB 6PK1555
			538 0060 10	
	16x		420 0222 10	
	 12 mm			
	16x		422 0102 10	
				713 0079 20
		 85 mm		713 6107 60
		 ; G6		772 0458 30
				814 0187 10
		 153 mm		
		 160 mm		814 0188 10
		 ; 		818 0199 10
		 ; 3.000		825 0266 10
				840 0177 10
		 right		840 0843 10
		 left		840 0842 10

2.0 TDI 4motion
CAAC; (103kW)

06.15-







































































		G6 ;  OA5 ;  RLG RLK	GearBOX	462 0235 10
		SAC		624 3517 33
				415 0734 10
				411 0133 10
				530 0550 10
				530 0550 32
				531 0825 10
				532 0161 10
				532 0582 10
				532 0623 10
		 ; +  ; A/C		529 0240 10
				532 0468 10
				534 0164 10
		## F-551406.XX		535 0124 10
		 ; A/C		FB 6PK1078
		 ; A/C		FB 6PK1555
				538 0060 10
		16x		420 0222 10
		 12 mm		
		16x		422 0102 10
				713 0079 20
		 85 mm		713 6107 60
		 ; G6		772 0458 30
				814 0187 10
		 153 mm		
		 160 mm		814 0188 10
		 ; 		818 0199 10
		 ; 3.000		825 0266 10
				840 0177 10
		right		840 0843 10



			SCHAEFFLER
--	---	--	-------------------

VW

TRANSPORTER T6 (SFD, SFE, SFL, SFZ)











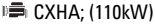

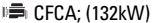















































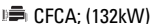





































2.0 TDI 4motion CAAC; (103kW)	06.15-	FAG	left		840 0842 10
2.0 TSI CJKB; (110kW)	04.15-	LUK	G6; 0A5; ID RLM	GearBOX	462 0235 10
					534 0422 10
			# 1000555 1013776 920851		535 0210 10
			16x		420 0224 10
			 12 mm		
			8x; 		422 0058 10
			1x		427 0016 10
			1x		553 0388 10
			1x		559 0196 10
			1x		711 0294 10
		FAG	left		713 0079 20
					713 6107 60
			 85 mm		
			 ; G6		772 0458 30
			 153 mm		814 0187 10
			 160 mm		814 0188 10
			 ; 		818 0199 10
			 ; 3.000		825 0266 10
					840 0177 10
			right		840 0843 10
			left		840 0842 10
2.0 TDI CXHA; (110kW)	08.15-	LUK	SAC		624 4011 33
					415 0882 10
			# F-551406.XX		532 0468 10
			 ; A/C		535 0124 10
			 ; A/C		FB 6PK1090
			11.16→		FB 6PK1555
			16x		538 0807 10
			 12 mm		420 0222 10
		FAG	left		713 0079 20
					713 6107 60
			 85 mm		
			 ; G6		772 0458 30
			 153 mm		814 0187 10
			 160 mm		814 0188 10
			 ; 		818 0199 10
			 ; 3.000		825 0266 10
					840 0177 10
			right		840 0843 10
			left		840 0842 10
2.0 TDI 4motion CXHA; (110kW)	05.16-	LUK	SAC		624 4011 33
					415 0882 10
			# F-551406.XX		532 0161 10
			 ; A/C		532 0623 10
			 ; A/C		532 0468 10
			11.16→		532 0468 10
			16x		535 0124 10
			12 mm		535 0124 10
		FAG	left		535 0124 10
					535 0124 10
			; G6		535 0124 10
			153 mm		FB 6PK1090
			160 mm		FB 6PK1555
			;		538 0807 10
			; 3.000		538 0807 10
					420 0222 10
			right		713 0079 20
			left		713 0079 20
					713 6107 60
			; G6		772 0458 30
			153 mm		814 0187 10
			160 mm		814 0188 10
			;		818 0199 10
			; 3.000		825 0266 10
					840 0177 10
			right		840 0843 10



			SCHAEFFLER
--	--	--	-------------------

VW

TRANSPORTER T6 (SFD, SFE, SFL, SFZ)



























2.0 TDI 4motion  CXHA; (110kW)	05.16-	FAG	 left		840 0842 10
	2.0 TDI  CFCA; (132kW)	04.15-	LUK	G6 ;  0A5 ;  ID R LJ	GearBOX
 DSG ;  ID PSP					602 0018 00
 DSG ;  ID SDG					624 3783 33
SAC					415 0618 09
 DSG				530 0550 10	
incl. 				530 0550 32	
				531 0825 10	
				532 0161 10	
				532 0582 10	
				532 0623 10	
				532 0468 10	
				534 0164 10	
				535 0124 10	
				FB 6PK1078	
				FB 6PK1555	
				538 0060 10	
16x				420 0222 10	
 12 mm				422 0102 10	
16x				713 0079 20	
FAG			 right		713 6107 60
	 left		772 0458 30		
	 85 mm		814 0187 10		
	  G6		814 0188 10		
	 153 mm		818 0199 10		
	 160 mm		825 0266 10		
	 ;  3.000		840 0177 10		
	 right		840 0843 10		
	 left		840 0842 10		
	2.0 TDI 4motion  CFCA; (132kW)	06.15-	LUK	G6 ;  0A5 ;  ID RLL	GearBOX
 DSG ;  ID PSR					602 0018 00
 DSG ;  ID SDD					624 3783 33
SAC					415 0618 09
 DSG				530 0550 10	
incl. 				530 0550 32	
				531 0825 10	
				532 0161 10	
				532 0582 10	
				532 0623 10	
				532 0468 10	
				534 0164 10	
				535 0124 10	
				FB 6PK1078	
				FB 6PK1555	
				538 0060 10	
16x				420 0222 10	
 12 mm				422 0102 10	
16x				713 0079 20	
FAG			 right		713 6107 60
	 left		772 0458 30		
	 85 mm		814 0187 10		
	  G6		814 0188 10		
	 153 mm		818 0199 10		
	 160 mm		825 0266 10		
	 ;  3.000		840 0177 10		
	 right		840 0843 10		
	 left		840 0842 10		



















































































			SCHAEFFLER
--	--	--	-------------------

VW

TRANSPORTER T6 (SFD, SFE, SFL, SFZ)

2.0 TDI 4motion CFCA; (132kW)	06.15-	FAG	right left		840 0843 10 840 0842 10
	2.0 TDI 2.0 TDI 4motion CXEB; (150kW)				532 0161 10 532 0623 10 532 0468 10
5# F-551406.XX				535 0124 10	
 ; A/C				FB 6PK1090	
 ; A/C				FB 6PK1555	
05.17→				538 0807 10	
16x				420 0222 10	
 12 mm					
FAG				713 0079 20	
				814 0187 10	
 153 mm				814 0188 10	
 160 mm					
 ; 				818 0199 10	
 ; 3.000				825 0266 10	
				840 0177 10	
right				840 0843 10	
left		840 0842 10			

TRANSPORTER T6 (SGA, SGB, SGG, SGH, SGJ)







































































2.0 TDI CAAA; CXGA; (62kW)	04.15-	LUK	SAC		623 3765 00
			 CAAA; START/STOP		415 0557 10
			 CXGA		
			 CAAA; START/STOP		415 0574 10
					411 0133 10
			 CAAA		512 0366 10
			 CAAA		530 0550 10
			 CAAA		530 0550 32
					531 0825 10
					532 0161 10
			 CAAA		532 0582 10
					532 0623 10
			 ; +  ; A/C		529 0240 10
					532 0468 10
			 ;  CAAA		534 0164 10
			5# F-551406.XX		535 0124 10
			 ;  CAAA; A/C		FB 6PK1078
			 ;  CXGA; A/C		FB 6PK1090
			 ; A/C		FB 6PK1555
			 CAAA		538 0060 10
		11.16→;  CXGA		538 0807 10	
		16x		420 0222 10	
		 12 mm			
		16x;  CAAA		422 0102 10	
		FAG		713 0079 20	
				Set 713 6107 60	
		 85 mm			
		right  ; G5;  7J...G...000001→		SET 772 0457 30	
		 ;  G6		SET 772 0458 30	
				814 0187 10	
		 153 mm		814 0188 10	
		 160 mm			
		 ; 		818 0199 10	
		 ; 3.000		825 0266 10	
				840 0177 10	
right		840 0843 10			
left		840 0842 10			
2.0 TDI CAAA; CXGA; (62kW)	04.15-06.16	LUK	SAC		623 3765 00
			 CAAA; START/STOP		415 0557 10
			 CXGA		
			 CAAA; START/STOP		415 0574 10
					411 0133 10
			 CAAA		512 0366 10
			 CAAA		530 0550 10
					530 0550 32



			SCHAEFFLER
--	--	--	-------------------

VW

TRANSPORTER T6 (SGA, SGB, SGG, SGH, SGJ)











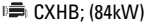













































































































2.0 TDI CAAB; CXGA; (62kW)	04.15-06.16		CAAA		531 0825 10
			CAAA		532 0161 10
			CAAA		532 0582 10
					532 0623 10
			;  ; A/C		529 0240 10
					532 0468 10
			; 		534 0164 10
			# F-551406.XX		535 0124 10
			;  ; A/C		FB 6PK1078
			;  ; A/C		FB 6PK1090
		; 		FB 6PK1555	
		CAAA		538 0060 10	
		CXGA		538 0807 10	
		16x		420 0222 10	
		12 mm			
		16x; CAAA		422 0102 10	
		85 mm		713 6107 60	
		right  ; G5; 7J...G...000001→		772 0457 30	
		 ; G6		772 0458 30	
		153 mm		814 0187 10	
160 mm		814 0188 10			
		818 0199 10			
; 3.000		825 0266 10			
right		840 0177 10			
left		840 0843 10			
left		840 0842 10			
CAAB; START/STOP		415 0557 10			
CXGB					
CAAB; START/STOP		415 0574 10			
		411 0133 10			
		512 0366 10			
CAAB		530 0550 32			
CAAB		531 0825 10			
		532 0161 10			
CAAB		532 0582 10			
		532 0623 10			
;  ; A/C		529 0240 10			
		532 0468 10			
; 		534 0164 10			
# F-551406.XX		535 0124 10			
;  ; A/C		FB 6PK1078			
;  ; A/C		FB 6PK1090			
; 		FB 6PK1555			
CAAB		538 0060 10			
CXGB; →11.16		538 0733 10			
11.16→; CXGB		538 0807 10			
16x		420 0222 10			
12 mm					
16x; CAAB		422 0102 10			
85 mm		713 6107 60			
right  ; 7J...G...000001→; G5; PR. MOH GOJ		772 0457 30			
153 mm		814 0187 10			
160 mm		814 0188 10			
		818 0199 10			
; 3.000		825 0266 10			
right		840 0177 10			
left		840 0843 10			
left		840 0842 10			



			SCHAEFFLER
--	---	--	-------------------

VW

TRANSPORTER T6 (SGA, SGB, SGG, SGH, SGJ)

































































































2.0 TDI  (84kW)	05.16-		 CXHB		623 3765 00			
			SAC		623 3765 00			
			 CXHB		415 0557 10			
					415 0557 10			
			 CXHB		411 0133 10			
					411 0133 10			
					532 0161 10			
					532 0623 10			
					532 0468 10			
			 # F-551406.XX		535 0124 10			
		 ;  CXGC;  A/C		FB 6PK1090				
		 ; A/C		FB 6PK1555				
		11.16 →		538 0807 10				
		16x		420 0222 10				
		 12 mm						
							713 0079 20	
					 right  ←;  7H...G...000001 →; G5	 SET	772 0457 30	
					 ←  right; G5 ;  7J...G...000001 →	 SET	772 0457 30	
							814 0187 10	
					 153 mm		814 0188 10	
					818 0199 10			
 ; 3.000					825 0266 10			
					840 0177 10			
 right					840 0843 10			
 left					840 0842 10			
	04.15-					 G6 ;  OA5 ;  ID RLF	 GearBOX	462 0235 10
						 DSG ;  ID PSP		602 0018 00
						 DSG ;  ID SDG		
						SAC		624 3517 33
						 DSG		415 0615 09
		incl. 		415 0734 10				
		 MANU		411 0133 10				
				530 0550 10				
				530 0550 32				
				531 0825 10				
				532 0161 10				
				532 0582 10				
				532 0623 10				
		 ; +  ; A/C		529 0240 10				
				532 0468 10				
		534 0164 10						
 # F-551406.XX		535 0124 10						
 ; A/C		FB 6PK1078						
 ; A/C		FB 6PK1555						
		538 0060 10						
16x		420 0222 10						
 12 mm								
16x		422 0102 10						
				 Set	713 0079 20			
			 85 mm		713 6107 60			
			 ← ; G6	 SET	772 0458 30			
					814 0187 10			
			 153 mm		814 0188 10			
					818 0199 10			
			 ; 3.000		825 0266 10			
					840 0177 10			
			 right		840 0843 10			
			 left		840 0842 10			
				06.15-		 G6 ;  OA5 ;  ID RLG RLK	 GearBOX	462 0235 10
						 DSG ;  ID PSR		602 0018 00
						 DSG ;  ID SDD		



			SCHAEFFLER
--	--	--	-------------------

VW











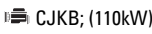



























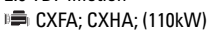











































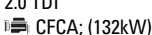





















TRANSPORTER T6 (SGA, SGB, SGG, SGH, SGJ)

2.0 TDI 4motion CAAC; (103kW)	06.15-	 	SAC ; + ; A/C ; # F-551406.XX ; A/C ; A/C 16x 12 mm 16x FAG ; 85 mm ; G6 153 mm 160 mm ; ; 3.000 right left	                                                    
2.0 TDI CXFA; CXHA; (110kW)	04.15-	 	G6 ; OA5 ; ID PSV ; DSG ; ID PSP ; DSG ; ID SDG SAC ; # F-551406.XX ; A/C ; A/C 11.16 → 16x 12 mm FAG ; 85 mm ; G6 153 mm 160 mm ; ; 3.000 right left	                            
2.0 TSI CJKB; (110kW)	04.15-	 	G6 ; OA5 ; PSZ RLM ; # 1000555 1013776 920851 16x 12 mm 8x ; 1x 1x 1x	       



			SCHAEFFLER
--	--	--	-------------------

VW
TRANSPORTER T6 (SGA, SGB, SGG, SGH, SGJ)































































































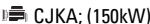











2.0 TSI  (110kW)	04.15-	 FAG	1x		711 0294 10		
					713 0079 20		
			 85 mm		713 6107 60		
			  ; G6		772 0458 30		
			 153 mm		814 0187 10		
			 160 mm		814 0188 10		
			 		818 0199 10		
			 ; 3.000		825 0266 10		
					840 0177 10		
			 right		840 0843 10		
			 left		840 0842 10		
					602 0018 00		
					624 4011 33		
					415 0882 10		
			2.0 TDI 4motion  (110kW)	08.15-		DSG ;  ID PSR	
DSG ;  ID SDD							
SAC		624 4011 33					
		415 0882 10					
		532 0161 10					
						532 0623 10	
						532 0468 10	
						532 0468 10	
	 # F-551406.XX					535 0124 10	
	 ; A/C					FB 6PK1090	
	 ; A/C					FB 6PK1555	
						538 0733 10	
	11.16→					538 0807 10	
	16x					420 0222 10	
	 12 mm					713 0079 20	
	FAG						713 6107 60
		  ; G6					772 0458 30
		 153 mm					814 0187 10
		 160 mm					814 0188 10
		 					818 0199 10
 ; 3.000						825 0266 10	
						840 0177 10	
 right						840 0843 10	
 left						840 0842 10	
						462 0235 10	
2.0 TDI  (132kW)	04.15-		G6 ;  OA5 ;  ID RLJ	GearBOX	462 0235 10		
			DSG ;  ID PSP		602 0018 00		
			DSG ;  ID SDG				
			SAC		624 3783 33		
			DSG		415 0618 09		
		incl. 					
		START/STOP		415 0853 10			
				411 0133 10			
						530 0550 10	
						530 0550 32	
						531 0825 10	
						532 0161 10	
						532 0582 10	
						532 0623 10	
			 ; +  ; A/C			529 0240 10	
				532 0468 10			
				534 0164 10			
 # F-551406.XX				535 0124 10			
 ; A/C			FB 6PK1078				
 ; A/C			FB 6PK1555				
			538 0060 10				
16x			420 0222 10				
 12 mm							
16x			422 0102 10				
FAG				713 0079 20			
				713 0079 20			



			SCHAEFFLER
--	--	--	-------------------

VW

TRANSPORTER T6 (SGA, SGB, SGG, SGH, SGJ)































































































2.0 TDI  CFCA; (132kW)	04.15-	FAG	 	 Set	713 6107 60
			 85 mm		772 0458 30
			  ; G6		814 0187 10
			 153 mm		814 0188 10
			 160 mm		818 0199 10
			 ; 		825 0266 10
			 ; 3.000		840 0177 10
			 right		840 0843 10
			 left		840 0842 10
			2.0 TDI 4motion  CFCA; (132kW)	06.15-	LUK
 DSG ;  ID PSR		602 0018 00			
 DSG ;  ID SDD		624 3783 33			
SAC		415 0618 09			
 DSG		415 0853 10			
incl. 		411 0133 10			
START/STOP		530 0550 10			
		530 0550 10			
		530 0550 32			
		531 0825 10			
		532 0161 10			
		532 0582 10			
		532 0623 10			
 ; +  ; A/C		529 0240 10			
		532 0468 10			
		534 0164 10			
# F-551406.XX		535 0124 10			
 ; A/C		FB 6PK1078			
 ; A/C		FB 6PK1555			
16x		538 0060 10			
 12 mm		420 0222 10			
16x		422 0102 10			
		713 0079 20			
		713 6107 60			
		772 0458 30			
		814 0187 10			
		814 0188 10			
		818 0199 10			
		825 0266 10			
		840 0177 10			
		840 0843 10			
		840 0842 10			
		534 0422 10			
		535 0210 10			
		420 0224 10			
		422 0058 10			
		427 0016 10			
		553 0388 10			
		559 0196 10			
		711 0294 10			
		713 0079 20			
		713 6107 60			
		814 0187 10			
		814 0188 10			
		818 0199 10			
		825 0266 10			
		840 0177 10			
		840 0843 10			
2.0 TSI 2.0 TSI 4motion  CJKA; (150kW)	04.15-				534 0422 10
			# 1000555 1013776 920851		535 0210 10
			16x		420 0224 10
			 12 mm		422 0058 10
			8x; 		422 0058 10
			1x		427 0016 10
			1x		553 0388 10
			1x		559 0196 10
			1x		711 0294 10
					713 0079 20
		713 6107 60			
		814 0187 10			
		814 0188 10			
		818 0199 10			
		825 0266 10			
		840 0177 10			
		840 0843 10			



			SCHAEFFLER
--	--	--	-------------------





VW

TRANSPORTER T6 (SGA, SGB, SGG, SGH, SGJ)

2.0 TSI 2.0 TSI 4motion  CJKA; (150kW)	04.15-	FAG	 left		840 0842 10
2.0 TDI  CXEB; (150kW)	06.15-	LUK	G6 ;  0A5 ;  ID PSX  DSG ;  ID PSP  DSG ;  ID SDG	GearBOX	462 0235 10 602 0018 00
			→10.17		530 0650 10
					530 0650 30
					531 0894 10
					532 0161 10
					532 0623 10
					532 0468 10
			 # F-551406.XX		535 0124 10
			 ; A/C		FB 6PK1090
			 ; A/C		FB 6PK1555
			→10.17		538 0733 10
			10.17→		538 0807 10
			16x		420 0222 10
			 12 mm		
		FAG			713 0079 20
			 		713 6107 60
			 		814 0187 10
			 		814 0188 10
			 ; 		818 0199 10
			 ; 3.000		825 0266 10
					840 0177 10
			 right		840 0843 10
			 left		840 0842 10
2.0 TDI 4motion  CXEB; (150kW)	06.15-	LUK	G6 ;  0A5 ;  ID PSY  DSG ;  ID PSR  DSG ;  ID SDD	GearBOX	462 0235 10 602 0018 00
			→10.17		530 0650 10
					530 0650 30
					531 0894 10
					532 0161 10
					532 0623 10
					532 0468 10
			 # F-551406.XX		535 0124 10
			 ; A/C		FB 6PK1090
			 ; A/C		FB 6PK1555
			→10.17		538 0733 10
			10.17→		538 0807 10
			16x		420 0222 10
			 12 mm		
		FAG			713 0079 20
			 		713 6107 60
			 		814 0187 10
			 		814 0188 10
			 ; 		818 0199 10
			 ; 3.000		825 0266 10
					840 0177 10
			 right		840 0843 10
			 left		840 0842 10







**Numerische Liste / Numerical listing / Liste numérique / Listado numérico / Elenco numerico /
Listy numerycznej / Перечень артикулов**

SCHAEFFLER				SCHAEFFLER			
1002226	RUV	CITROËN	114, 115, 116, 118	411 0186 11	LUK	IVECO	256, 257, 258, 259, 260, 261,
1002226	RUV	PEUGEOT	482, 483, 486				262, 263, 264, 265, 266, 267,
33109	FAG	MERCEDES- BENZ	296, 297				268, 269, 270, 271, 272, 273,
33205	FAG	MERCEDES- BENZ	296, 297				274, 275, 281, 282, 284, 285,
400 0478 10	INA	VW	615, 616	411 0230 10	LUK	HYUNDAI	286, 287, 288, 289
400 0479 10	INA	VW	615, 616	411 0239 10	LUK	FIAT	217, 218, 219, 220, 221
400 0577 10	INA	OPEL	410, 411, 412, 415	411 0253 10	LUK	FIAT	142, 143
400 0577 10	INA	VAUXHALL	569, 570, 571, 574	415 0138 10	LUK	FIAT	168, 169, 170, 171, 172, 173, 174
411 0007 10	LUK	VW	629	415 0146 10	LUK	NISSAN	182
411 0119 10	LUK	FORD	214	415 0146 10	LUK	OPEL	403, 408
411 0120 10	LUK	CITROËN	136	415 0146 10	LUK	RENAULT	448, 454, 459
411 0120 10	LUK	FORD	188, 189, 191, 192, 193, 194,	415 0146 10	LUK	VAUXHALL	547, 553, 558
			195, 197, 198, 199, 200, 201,	415 0168 10	LUK	FORD	601, 602, 607, 608, 612, 613
			202, 203, 204, 205, 206, 207,	415 0169 10	LUK	FORD	188, 189
			208, 209, 210, 211, 212, 213, 214	415 0180 10	LUK	FORD	189, 190, 191
411 0120 10	LUK	PEUGEOT	471	415 0185 10	LUK	FORD	191, 192, 193
411 0121 10	LUK	OPEL	414	415 0191 10	LUK	VW	214
411 0121 10	LUK	VAUXHALL	573	415 0191 10	LUK	VW	641
411 0122 10	LUK	FIAT	142, 143, 144, 149, 150, 151, 165	415 0196 10	LUK	MERCEDES- BENZ	293
411 0122 10	LUK	OPEL	416	415 0208 10	LUK	VW	641, 642
411 0122 10	LUK	VAUXHALL	575	415 0221 10	LUK	IVECO	228, 229, 230, 231, 232, 233,
411 0124 10	LUK	FIAT	176				234, 235, 236, 244, 245, 246,
411 0124 10	LUK	OPEL	410, 411				247, 248, 249, 250, 251, 255,
411 0124 10	LUK	VAUXHALL	569, 570				256, 257, 258, 259, 260, 261,
411 0133 10	LUK	VW	620, 621, 622, 623, 624, 625,				262, 263, 264, 265, 266, 267,
			626, 627, 632, 633, 634, 635,				268, 269, 270, 271, 272, 273,
			636, 637, 638, 639, 642, 643,				274, 275, 281, 284, 285, 286,
			644, 645, 646, 647, 648, 649,				287, 288, 289
			650, 651, 656, 657, 658, 659,	415 0222 10	LUK	IVECO	222, 223, 224, 225, 226, 227,
			660, 661, 662, 663, 666, 667,				229, 230, 236, 237, 239, 241,
			668, 671, 672, 673, 674, 675, 676				242, 252
411 0133 11	LUK	VW	641, 653, 654, 663, 664, 665	415 0232 10	LUK	OPEL	410, 411
411 0139 11	LUK	VW	639, 640	415 0232 10	LUK	VAUXHALL	569, 570
411 0147 10	LUK	MERCEDES- BENZ	291, 292, 293, 297, 298, 299,	415 0239 10	LUK	MERCEDES- BENZ	291, 292
			300, 301, 303, 304, 305, 308,				
			309, 311, 312, 313, 314, 315,	415 0242 10	LUK	MERCEDES- BENZ	357, 358, 359, 360, 361, 362,
			316, 317, 320, 321, 322, 323,				363, 366
			327, 328, 329, 330, 331, 332,	415 0243 10	LUK	MERCEDES- BENZ	295, 296
			333, 335, 336, 338, 339, 341,				
			343, 344, 345, 348, 349, 352,	415 0247 10	LUK	MERCEDES- BENZ	293
			353, 354, 355, 357, 358, 359,				
			360, 361, 362, 363, 366	415 0250 10	LUK	VW	620, 642, 643, 644, 656, 657
411 0148 10	LUK	MERCEDES- BENZ	326, 327, 349, 351	415 0251 10	LUK	VW	653, 654, 664, 665
411 0150 10	LUK	MERCEDES- BENZ	295, 298, 299, 300, 301, 302,	415 0256 10	LUK	OPEL	414
			303, 304, 307, 313, 314, 315,	415 0256 10	LUK	VAUXHALL	573
			316, 318, 319, 320, 324, 325,	415 0268 10	LUK	IVECO	222, 223, 224, 225, 226, 227,
			335, 337, 342, 343, 345, 346,				228, 229, 230, 236, 237, 238,
			347, 350, 351, 357, 360, 364,				239, 240, 241, 242, 243, 244,
			365, 367, 368				250, 252, 253, 254, 255
411 0154 10	LUK	MERCEDES- BENZ	306	415 0271 10	LUK	VW	653, 663, 664
411 0159 10	LUK	FIAT	179, 180, 181, 182	415 0293 10	LUK	MERCEDES- BENZ	306
411 0159 10	LUK	PEUGEOT	476, 478				
411 0160 10	LUK	MERCEDES- BENZ	295, 301, 303, 304, 305, 317,	415 0300 10	LUK	HYUNDAI	217, 218, 219, 220, 221
			321, 322, 323, 336, 345, 348, 349	415 0304 10	LUK	MERCEDES- BENZ	308, 309, 327, 328, 329, 330,
411 0166 10	LUK	CITROËN	119, 120, 121, 124				331, 332, 333, 338, 339, 352,
411 0166 10	LUK	PEUGEOT	480, 486, 487, 488, 489	415 0309 10	LUK	MERCEDES- BENZ	353, 354, 355
411 0169 10	LUK	FIAT	141				297, 298, 299, 300, 301, 303,
411 0169 10	LUK	OPEL	416				304, 305, 311, 312, 313, 314,
411 0170 10	LUK	CITROËN	138				315, 316, 317, 320, 321, 322,
411 0170 10	LUK	FIAT	174, 175	415 0320 10	LUK	FIAT	323, 335, 336, 341, 343, 344,
411 0170 10	LUK	PEUGEOT	473, 474	415 0320 10	LUK	PEUGEOT	345, 348, 349
411 0170 11	LUK	FIAT	168, 169, 170, 171, 172, 173, 174	415 0325 10	LUK	HYUNDAI	179, 180
411 0186 10	LUK	IVECO	222, 223, 224, 225, 226, 227,	415 0329 10	LUK	FIAT	476, 477
			228, 230, 236, 237, 238, 239,	415 0335 10	LUK	VW	217, 218, 219, 220
			240, 241, 242, 243, 244, 250,	415 0336 10	LUK	VW	176
			252, 253, 254, 255, 276, 277,	415 0337 10	LUK	VW	639, 640
			278, 281, 282, 283, 284	415 0355 10	LUK	FORD	640
411 0186 11	LUK	IVECO	228, 229, 230, 231, 232, 233,	415 0372 10	LUK	CITROËN	639, 640
			234, 235, 236, 244, 245, 246,	415 0372 10	LUK	PEUGEOT	189, 190, 191
			247, 248, 249, 250, 251, 255,	415 0375 10	LUK	CITROËN	136
				415 0375 10	LUK	FIAT	471
							138
							174, 175





*Unique LCV Application

**Numerische Liste / Numerical listing / Liste numérique / Listado numérico / Elenco numerico /
Listy numerycznej / Перечень артикулов**

SCHAEFFLER				SCHAEFFLER				
415 0375 10	LUK	PEUGEOT		472, 473, 474	415 0743 10	LUK	CITROËN	127
415 0378 10	LUK	FORD		188, 189	415 0743 10	LUK	PEUGEOT	492
415 0388 10	LUK	FORD	193, 203, 204, 205, 206, 207, 208		415 0744 09	LUK	VW	626, 627, 632, 633, 634, 635
415 0396 10	LUK	CITROËN		119, 120, 121, 124	415 0768 09	LUK	VW	629
415 0396 10	LUK	PEUGEOT		486, 487, 488, 489, 491	415 0796 10	LUK	FIAT	182, 183
415 0400 10	LUK	NISSAN		387	415 0796 10	LUK	MERCEDES-BENZ	373
415 0400 10	LUK	RENAULT		505, 506	415 0796 10	LUK	NISSAN	388, 389
415 0415 10	LUK	FORD		199, 200	415 0796 10	LUK	OPEL	460, 461, 462, 463
415 0431 10	LUK	VW	621, 622, 623, 625, 626, 627, 632, 633, 634		415 0796 10	LUK	RENAULT	559, 560, 561, 562, 563
415 0438 10	LUK	FORD		197, 201, 202, 203, 204	415 0796 10	LUK	VAUXHALL	614, 615
415 0442 10	LUK	OPEL		410, 411	415 0808 10	LUK	IVECO	280, 287
415 0442 10	LUK	VAUXHALL		569, 570	415 0853 10	LUK	VW	651, 662, 663, 675, 676
415 0485 10	LUK	NISSAN		390, 391, 392, 393, 397	415 0873 10	LUK	FORD	183
415 0485 10	LUK	OPEL		433, 435, 437, 438, 440, 442	415 0882 10	LUK	VW	669, 674, 675
415 0485 10	LUK	RENAULT		526, 527, 528, 529, 530, 532, 535, 536, 537, 538, 539	415 0931 10	LUK	MERCEDES-BENZ	357
415 0485 10	LUK	VAUXHALL		589, 591, 595	420 0042 10	INA	MERCEDES-BENZ	294
415 0490 10	LUK	NISSAN		392, 393, 394, 395, 396, 398, 399, 400	420 0043 10	INA	VW	624, 647, 659
415 0490 10	LUK	OPEL		433, 436, 440, 443	420 0050 10	INA	FIAT	148
415 0490 10	LUK	RENAULT		527, 528, 531, 533, 534, 535, 536, 537, 539, 540, 541	420 0061 10	INA	GAZ	216, 217
415 0490 10	LUK	VAUXHALL		589, 592	420 0063 10	INA	MERCEDES-BENZ	369, 370, 372
415 0492 10	LUK	RENAULT		503	420 0063 10	INA	NISSAN	378, 379, 380, 381, 382, 383, 384, 385, 408, 409, 410
415 0493 10	LUK	PEUGEOT		491	420 0063 10	INA	OPEL	419, 420, 421, 423, 424, 425, 426, 427, 428, 429, 430, 431, 448, 449, 453, 454, 459
415 0529 10	LUK	FIAT		181	420 0063 10	INA	RENAULT	509, 510, 511, 512, 515, 516, 517, 518, 519, 520, 521, 522, 523, 524, 547, 548, 552, 553, 558, 559
415 0529 10	LUK	PEUGEOT		478	420 0063 10	INA	VAUXHALL	577, 578, 579, 581, 582, 583, 586, 587, 602, 603, 608, 609, 613
415 0537 11	LUK	FORD		184, 185	420 0072 10	INA	OPEL	412
415 0540 10	LUK	VW	647, 648, 649, 650, 660, 661		420 0072 10	INA	VAUXHALL	571
415 0541 10	LUK	FIAT		142, 143	420 0076 10	INA	MERCEDES-BENZ	369, 370, 372
415 0541 10	LUK	OPEL		416	420 0086 10	INA	CITROËN	117, 118, 120, 121, 122, 123, 125, 126, 127
415 0541 10	LUK	VAUXHALL		575	420 0086 10	INA	FIAT	179, 183
415 0557 10	LUK	VW	645, 646, 658, 666, 667, 671, 672, 673		420 0086 10	INA	FORD	184, 185, 186, 187
415 0560 10	LUK	FORD		209	420 0086 10	INA	MERCEDES-BENZ	296, 306, 308, 309, 310, 311, 323, 326, 327, 328, 329, 330, 331, 332, 333, 334, 338, 339, 340, 341, 349, 351, 352, 353, 354, 355, 356, 357, 369, 371, 373
415 0562 10	LUK	FORD	188, 194, 197, 202, 211, 212, 213		420 0086 10	INA	NISSAN	388, 389, 390, 391, 392, 393, 394, 395, 396, 397, 398, 399, 400, 401, 406, 407
415 0574 10	LUK	VW	624, 645, 646, 658, 659, 666, 667, 671, 672		420 0086 10	INA	OPEL	433, 434, 435, 436, 437, 438, 439, 440, 441, 442, 443, 445, 446, 451, 452, 456, 457, 460, 461, 462, 463
415 0583 10	LUK	VW	622, 623, 625, 626, 627, 632, 633, 634, 635		420 0086 10	INA	PEUGEOT	475, 480, 481, 485, 488, 489, 490, 491, 492, 495
415 0615 09	LUK	VW	647, 649, 660, 661, 668, 673		420 0086 10	INA	RENAULT	526, 527, 528, 530, 531, 532, 535, 536, 537, 538, 539, 540, 545, 551, 556, 559, 560, 561, 562, 563
415 0618 09	LUK	VW	647, 649, 651, 661, 662, 663, 670, 675, 676		420 0086 10	INA	VAUXHALL	589, 590, 591, 592, 594, 595, 596, 597, 599, 600, 605, 610, 614, 615
415 0620 10	LUK	VW	636, 637, 638		420 0098 10	INA	VW	615, 616, 617
415 0626 09	LUK	VW	618, 630		420 0099 10	INA	NISSAN	402, 407, 408
415 0628 10	LUK	FORD	195, 198, 200, 201, 211, 212, 213, 214		420 0099 10	INA	OPEL	446, 447, 452, 453, 457, 458
415 0649 10	LUK	VW	638, 639		420 0099 10	INA	RENAULT	500, 501, 507, 508, 545, 546, 551, 552, 557
415 0657 10	LUK	MERCEDES-BENZ	373, 374		420 0099 10	INA	VAUXHALL	600, 601, 606, 611
415 0660 10	LUK	MERCEDES-BENZ	295, 298, 299, 300, 301, 302, 303, 304, 307, 313, 314, 315, 316, 318, 319, 320, 324, 325, 335, 337, 342, 343, 345, 346, 347, 349, 350, 351, 360, 364, 365, 367, 368		420 0105 10	INA	PEUGEOT	478, 479
415 0663 10	LUK	FIAT	165		420 0118 10	INA	OPEL	412, 413
415 0673 10	LUK	FIAT	168, 169, 170, 171, 172, 173, 174		420 0118 10	INA	VAUXHALL	571, 572
415 0678 10	LUK	FIAT	141					
415 0678 10	LUK	OPEL	416					
415 0679 10	LUK	FIAT	142, 143					
415 0679 10	LUK	OPEL	416					
415 0679 10	LUK	VAUXHALL	575					
415 0694 10	LUK	FIAT	149, 150, 151					
415 0707 10	LUK	FIAT	144					
415 0715 10	LUK	PEUGEOT	480					
415 0720 10	LUK	FIAT	142, 143					
415 0720 10	LUK	OPEL	416					
415 0720 10	LUK	VAUXHALL	575					
415 0723 09	LUK	VW	620					
415 0734 10	LUK	VW	647, 648, 649, 650, 660, 661, 668, 673, 674					
415 0738 10	LUK	IVECO	276, 277, 278, 281, 282, 283, 284					





*Unique LCV Application

Numerische Liste / Numerical listing / Liste numérique / Listado numérico / Elenco numerico / Listy numerycznej / Перечень артикулов

SCHAEFFLER				SCHAEFFLER			
420 0170 10	INA	MERCEDES-BENZ	291, 292, 295, 296, 297, 298, 299, 300, 301, 303, 304, 305, 306, 312, 313, 314, 315, 316, 317, 318, 320, 321, 322, 323, 335, 336, 337, 341, 342, 343, 344, 345, 348, 349, 357, 358, 359, 360, 361, 362, 363, 364, 366, 367	422 0056 10	INA	MERCEDES-BENZ	340, 352, 353, 354, 355, 356, 369, 371
420 0172 10	INA	VW	655, 656, 665, 666	422 0058 10	INA	VW	650, 652, 662, 669, 674, 676
420 0181 10	INA	FIAT	139, 140, 142, 143, 144, 146, 165, 177	422 0063 10	INA	HYUNDAI	217, 218, 219, 220, 221, 222
420 0181 10	INA	OPEL	415, 417	422 0064 10	INA	FIAT	139, 140, 146, 177
420 0181 10	INA	VAUXHALL	574, 575, 576	422 0064 10	INA	OPEL	415
420 0182 10	INA	HYUNDAI	217, 218, 219, 220, 221, 222	422 0064 10	INA	VAUXHALL	574
420 0200 10	INA	HYUNDAI	217	422 0072 10	INA	VW	655, 656, 665, 666
420 0200 10	INA	VAUXHALL	376	422 0075 10	INA	FIAT	142, 143, 144, 165
420 0209 10	INA	VW	622, 626	422 0075 10	INA	OPEL	417
420 0210 10	INA	FIAT	140, 141	422 0075 10	INA	VAUXHALL	575, 576
420 0210 10	INA	OPEL	416	422 0078 10	INA	FIAT	183
420 0210 10	INA	VAUXHALL	575	422 0078 10	INA	MERCEDES-BENZ	373
420 0218 10	INA	MERCEDES-BENZ	306, 323, 326, 327, 349, 351	422 0078 10	INA	NISSAN	388, 389, 390, 391, 392, 393, 394, 395, 396, 397, 398, 399, 400, 401, 406, 407
420 0222 10	INA	VW	617, 619, 623, 624, 625, 626, 627, 630, 631, 632, 633, 634, 635, 636, 637, 638, 639, 645, 646, 648, 649, 650, 651, 652, 658, 659, 660, 661, 662, 663, 666, 667, 668, 669, 670, 671, 672, 673, 674, 675, 676, 677	422 0078 10	INA	OPEL	433, 434, 435, 436, 437, 438, 439, 440, 441, 442, 443, 445, 446, 451, 452, 456, 457, 460, 461, 462, 463
420 0224 10	INA	VW	619, 650, 652, 662, 669, 674, 676	422 0078 10	INA	RENAULT	526, 527, 528, 530, 531, 532, 535, 536, 537, 538, 539, 540, 545, 551, 556, 559, 560, 561, 562, 563
420 0225 10	INA	MERCEDES-BENZ	295, 298, 299, 300, 301, 302, 303, 304, 307, 313, 314, 315, 317, 318, 319, 320, 324, 325, 326, 335, 337, 338, 342, 343, 345, 346, 347, 350, 351, 357, 361, 364, 365, 367, 368, 373, 374, 375	422 0078 10	INA	VAUXHALL	589, 590, 591, 592, 594, 595, 596, 597, 599, 600, 605, 610, 614, 615
420 0226 10	INA	CITROËN	122, 126	422 0099 10	INA	MERCEDES-BENZ	295, 298, 299, 300, 301, 302, 303, 304, 307, 313, 314, 315, 317, 318, 319, 320, 324, 325, 326, 335, 337, 338, 342, 343, 345, 346, 347, 350, 351, 357, 361, 364, 365, 367, 368, 373, 374, 375
420 0226 10	INA	PEUGEOT	490, 492	422 0102 10	INA	VW	617, 619, 623, 624, 625, 626, 627, 630, 631, 632, 633, 634, 635, 636, 637, 638, 639, 645, 646, 648, 649, 650, 651, 652, 658, 659, 660, 661, 662, 663, 666, 667, 668, 670, 671, 672, 673, 674, 675, 676
420 0229 10	INA	CITROËN	122, 126	422 0107 10	INA	CITROËN	134, 135
420 0229 10	INA	PEUGEOT	490, 492	422 0107 10	INA	PEUGEOT	469, 470, 480, 481
420 0232 10	INA	FIAT	180, 181	422 0110 10	INA	HYUNDAI	217, 218, 219, 220, 221, 222
420 0232 10	INA	PEUGEOT	475, 476, 477, 478, 479	422 0124 10	INA	FIAT	180, 181
420 0234 10	INA	CITROËN	134, 135	422 0124 10	INA	PEUGEOT	475, 477, 479
420 0234 10	INA	PEUGEOT	469, 470, 480, 481	422 0125 10	INA	FIAT	180, 181
420 0243 10	INA	FIAT	179, 181	422 0125 10	INA	PEUGEOT	475, 477, 479
420 0243 10	INA	PEUGEOT	478	422 0144 10	INA	MERCEDES-BENZ	306, 323, 326, 327, 349, 351
420 0254 10	INA	VW	628, 629, 631	422 0221 10	INA	CITROËN	122, 126
421 0010 10	INA	CITROËN	129	422 0221 10	INA	PEUGEOT	490, 492
421 0010 10	INA	FIAT	156, 157, 158	422 0222 10	INA	CITROËN	122, 126
421 0010 10	INA	PEUGEOT	464, 465	422 0222 10	INA	PEUGEOT	490, 492
421 0012 10	INA	FIAT	149, 150, 151	422 0223 10	INA	CITROËN	122, 126
421 0017 10	INA	TOYOTA	563, 564, 565, 568	422 0223 10	INA	PEUGEOT	490, 492
421 0059 10	INA	OPEL	413, 414	422 0224 10	INA	CITROËN	122, 126
421 0059 10	INA	VAUXHALL	573, 574	422 0224 10	INA	PEUGEOT	490, 492
422 0006 10	INA	OPEL	412	422 0225 10	INA	CITROËN	122, 126
422 0006 10	INA	VAUXHALL	571	422 0225 10	INA	PEUGEOT	490, 492
422 0007 10	INA	VW	619	422 0226 10	INA	CITROËN	122, 126
422 0009 10	INA	NISSAN	402, 407, 408	422 0226 10	INA	PEUGEOT	490, 492
422 0009 10	INA	OPEL	446, 447, 452, 453, 457, 458	422 0236 10	INA	VW	628, 629, 631
422 0009 10	INA	RENAULT	500, 501, 507, 508, 545, 546, 551, 552, 557	422 0238 10	INA	PEUGEOT	476, 478
422 0009 10	INA	VAUXHALL	600, 601, 606, 611	427 0009 10	INA	FIAT	147, 177, 178
422 0012 10	INA	VW	616, 617	427 0013 10	INA	FIAT	147
422 0018 10	INA	CITROËN	117, 118, 120, 121, 122, 123, 125, 126, 127	427 0016 10	INA	VW	650, 652, 662, 669, 674, 676
422 0018 10	INA	FIAT	179	427 0038 10	INA	FORD	183, 186
422 0018 10	INA	FORD	184, 185, 186, 187	427 1001 30	INA	FIAT	147, 177, 178
422 0018 10	INA	PEUGEOT	475, 480, 481, 485, 488, 489, 490, 491, 492, 495	427 1031 10	INA	FORD	183, 186
422 0055 10	INA	MERCEDES-BENZ	310, 311, 334, 340, 341, 356, 357, 373	427 1032 10	INA	FORD	184, 186
422 0056 10	INA	MERCEDES-BENZ	296, 308, 309, 310, 328, 329, 330, 331, 332, 333, 338, 339,	428 0027 30	INA	VW	639, 640, 641
				428 0029 30	INA	PEUGEOT	493





*Unique LCV Application

Numerische Liste / Numerical listing / Liste numérique / Listado numérico / Elenco numerico / Listy numerycznej / Перечень артикулов

SCHAEFFLER				SCHAEFFLER			
428 0030 30	INA	FIAT	140, 145, 146, 176	428 0185 10	INA	RENAULT	523, 524, 546, 547, 548, 552, 553, 558, 559
428 0030 30	INA	OPEL	410, 411	428 0185 10	INA	VAUXHALL	576, 577, 578, 579, 581, 582, 583, 586, 587, 601, 602, 603, 607, 608, 609, 612, 613
428 0030 30	INA	VAUXHALL	569, 570	428 0186 10	INA	NISSAN	378, 379, 380, 381, 382, 383, 384, 385, 403, 408, 409, 410
428 0032 30	INA	CITROËN	116, 118, 119, 120, 124	428 0186 10	INA	OPEL	419, 420, 421, 423, 424, 425, 426, 427, 428, 430, 431, 448, 449, 453, 454, 459
428 0032 30	INA	FIAT	178	428 0186 10	INA	RENAULT	509, 510, 511, 512, 515, 516, 517, 518, 519, 520, 521, 522, 523, 524, 547, 548, 552, 553, 558, 559
428 0032 30	INA	PEUGEOT	475, 483, 484, 485, 487, 488, 491	428 0186 10	INA	VAUXHALL	576, 577, 578, 579, 581, 582, 583, 586, 587, 601, 602, 603, 607, 608, 609, 612, 613
428 0033 30	INA	CITROËN	119, 123, 125	428 0189 10	INA	FIAT	180, 181
428 0033 30	INA	PEUGEOT	486, 491	428 0189 10	INA	PEUGEOT	477, 479
428 0034 30	INA	CITROËN	127, 128, 130, 131	428 0190 10	INA	FIAT	180, 181
428 0034 30	INA	FIAT	152, 155, 182	428 0190 10	INA	PEUGEOT	477, 479
428 0034 30	INA	PEUGEOT	463, 465, 466, 493, 494	428 0190 10	INA	NISSAN	386, 387, 388
428 0039 30	INA	VW	620, 621, 642, 644, 656, 658	428 0198 10	INA	RENAULT	504, 505, 506
428 0040 30	INA	VW	653, 654, 664, 665	462 0151 10	LUK	CITROËN	114, 115
428 0041 30	INA	OPEL	412	462 0151 10	LUK	FIAT	177
428 0041 30	INA	VAUXHALL	571, 572	462 0151 10	LUK	PEUGEOT	481, 482
428 0042 30	INA	VW	620, 643, 644, 657	462 0152 10	LUK	MERCEDES-BENZ	297, 298, 299, 300, 301, 304, 305, 308, 310, 311, 312, 313, 314, 315, 320, 321, 327, 328, 333, 334, 341, 343, 348, 352, 356, 359, 360, 361, 362, 363, 364, 366, 367
428 0044 30	INA	VW	653, 654, 664, 665	462 0152 10	LUK	VW	639, 640
428 0050 30	INA	VW	618	462 0153 10	LUK	FORD	183, 184, 185, 214, 215, 216
428 0080 10	INA	CITROËN	131, 132, 133, 134	462 0154 10	LUK	FIAT	140, 147, 148
428 0080 10	INA	FIAT	153, 154, 160, 161, 162, 163, 164, 165	462 0155 10	LUK	OPEL	418, 422, 444, 446, 447, 448, 450, 452, 454, 455, 457, 458, 459
428 0080 10	INA	IVECO	224, 228, 231, 233, 234, 235	462 0155 10	LUK	RENAULT	508, 509, 510, 514, 521, 522, 543, 544, 546, 549, 550, 551, 554, 557
428 0080 10	INA	PEUGEOT	467, 468, 469	462 0155 10	LUK	VAUXHALL	580, 584, 597, 598, 600, 602, 603, 604, 606, 607, 609, 611, 612
428 0092 10	INA	MERCEDES-BENZ	291, 292, 297, 298, 299, 300, 301, 303, 304, 305, 306, 312, 313, 314, 315, 316, 317, 318, 320, 321, 322, 323, 335, 336, 337, 341, 342, 343, 344, 345, 348, 349, 357, 358, 359, 360, 361, 362, 363, 364, 366, 367	462 0195 10	LUK	VW	616, 617, 618, 621, 623
428 0093 10	INA	OPEL	412, 413	462 0196 10	LUK	VW	615, 616, 617, 618, 619, 621, 623
428 0093 10	INA	VAUXHALL	571, 572	462 0199 10	LUK	VW	653, 654, 655, 663, 664, 665
428 0097 10	INA	OPEL	413, 414	462 0200 10	LUK	VW	647, 648, 649, 650, 651, 652, 653, 654, 655, 661, 662, 663, 664, 665
428 0097 10	INA	VAUXHALL	573, 574	462 0202 10	LUK	OPEL	418, 419, 420, 422, 423, 426, 428, 429, 431, 448, 454, 459
428 0098 10	INA	OPEL	413, 414	462 0202 10	LUK	RENAULT	509, 510, 516, 517, 520, 521, 522
428 0098 10	INA	VAUXHALL	573, 574	462 0202 10	LUK	VAUXHALL	576, 577, 580, 581, 584, 585, 586, 597, 602, 603, 607, 609, 612
428 0100 10	INA	FIAT	149	462 0203 10	LUK	OPEL	418, 422, 444, 446, 447, 450, 452, 454, 455, 457, 458
428 0122 10	INA	VAUXHALL	571	462 0203 10	LUK	RENAULT	508, 509, 514, 516, 517, 520, 521, 522, 543, 545, 546, 549, 551, 554, 557
428 0124 10	INA	RENAULT	507	462 0203 10	LUK	VAUXHALL	576, 577, 580, 581, 584, 585, 586, 598, 600, 604, 606, 611
428 0127 10	INA	HYUNDAI	221	462 0204 10	LUK	FORD	193, 203, 204, 205, 206, 207
428 0139 10	INA	FIAT	150, 151	462 0205 10	LUK	RENAULT	506
428 0149 10	INA	FIAT	144	462 0211 10	LUK	FORD	195, 198, 200, 201, 203, 204, 205, 206, 207, 209, 211, 212
428 0160 10	INA	FIAT	179, 180, 181	462 0231 10	LUK	RENAULT	508, 509, 510, 514, 516, 517, 520, 521, 522, 554
428 0160 10	INA	PEUGEOT	476, 478	462 0235 10	LUK	VW	668, 669, 670, 673, 674, 675, 676, 677
428 0161 10	INA	VW	619	462 0238 10	LUK	MERCEDES-BENZ	297, 298, 299, 300, 304, 305, 308, 310, 311, 312, 313, 314, 315, 316, 320, 321, 322, 327, 329, 333, 334, 336, 338, 340, 341, 342, 343, 344, 347, 348, 349, 352, 353, 356
428 0163 10	INA	NISSAN	386, 387	462 0238 10	LUK	VW	640
428 0163 10	INA	RENAULT	496, 497, 498, 499, 500, 504	462 0239 10	LUK	VW	636, 637, 638, 639, 640
428 0166 10	INA	FIAT	147, 177, 178				
428 0168 10	INA	FIAT	179, 180, 181				
428 0168 10	INA	PEUGEOT	476, 478				
428 0169 10	INA	VW	616, 617				
428 0172 10	INA	VW	616, 617				
428 0173 10	INA	VW	617				
428 0183 10	INA	CITROËN	117, 118, 120, 121, 122, 123, 125, 126, 127				
428 0183 10	INA	FIAT	179				
428 0183 10	INA	FORD	184, 185, 186, 187				
428 0183 10	INA	PEUGEOT	475, 480, 481, 485, 488, 489, 490, 492, 495				
428 0184 10	INA	MERCEDES-BENZ	291, 292, 297, 298, 299, 300, 301, 303, 304, 305, 306, 312, 313, 314, 315, 316, 317, 318, 320, 321, 322, 323, 335, 336, 337, 341, 342, 343, 344, 345, 348, 349, 357, 358, 359, 360, 361, 362, 363, 364, 366, 367				
428 0185 10	INA	NISSAN	378, 379, 380, 381, 382, 383, 384, 385, 403, 408, 409, 410				
428 0185 10	INA	OPEL	419, 420, 421, 423, 424, 425, 426, 427, 428, 430, 431, 448, 449, 453, 454, 459				
428 0185 10	INA	RENAULT	509, 510, 511, 512, 515, 516, 517, 518, 519, 520, 521, 522,				





*Unique LCV Application

Numerische Liste / Numerical listing / Liste numérique / Listado numérico / Elenco numerico / Listy numerycznej / Перечень артикулов

SCHAEFFLER				SCHAEFFLER			
462 0313 10	LUK	MERCEDES-BENZ	297, 298, 299, 300, 304, 305, 308, 310, 311, 312, 313, 314, 315, 316, 320, 321, 322, 327, 329, 333, 334, 336, 338, 340, 341, 342, 343, 344, 347, 348, 349, 352, 353, 356	529 0118 10	INA	VAUXHALL	580, 585, 598, 601, 603, 604, 606
462 0332 10	LUK	MERCEDES-BENZ	297, 298, 299, 304, 305, 308, 310, 311, 312, 313, 314, 316, 320, 321, 322, 327, 329, 333, 334, 336, 338, 340, 341, 342, 343, 344, 347, 348, 349, 352, 353, 356	529 0124 10	INA	NISSAN	377, 402, 404, 405, 406, 407, 408
462 0333 10	LUK	VW	617, 618, 620, 624, 630, 631, 632	529 0124 10	INA	OPEL	418, 422, 444, 445, 446, 447, 450, 452, 453, 455, 457, 458
512 0010 10	LUK	VW	616, 617, 618, 619, 620, 622, 623, 624	529 0124 10	INA	RENAULT	508, 515, 543, 544, 545, 546, 549, 550, 551, 554, 555, 557
512 0012 10	LUK	VW	616, 617, 618, 619, 622, 623	529 0124 10	INA	VAUXHALL	580, 585, 598, 600, 601, 603, 604, 606, 611
512 0018 10	LUK	GAZ	216, 217	529 0145 10	INA	RENAULT	500, 501
512 0018 10	LUK	PEUGEOT	478, 479	529 0149 10	INA	CITROËN	114, 124
512 0038 10	LUK	VW	641	529 0149 10	INA	PEUGEOT	482
512 0359 10	LUK	FORD	189, 190, 191, 192, 193, 203, 204	529 0156 10	INA	FIAT	182
512 0366 10	LUK	VW	642, 643, 644, 645, 646, 647, 648, 649, 650, 651, 652, 653, 654, 655, 656, 657, 658, 659, 660, 661, 662, 663, 664, 665, 666, 671, 672	529 0156 10	INA	PEUGEOT	494
512 0437 10	LUK	FIAT	139, 146, 149, 150, 151	529 0159 10	INA	VW	628, 629
512 0437 10	LUK	OPEL	415	529 0165 10	INA	NISSAN	386, 387, 388
512 0437 10	LUK	VAUXHALL	574	529 0165 10	INA	RENAULT	497, 503, 504, 505
529 0008 10	INA	OPEL	412, 413	529 0165 10	INA	PEUGEOT	493
529 0008 10	INA	VAUXHALL	570, 571, 572	529 0167 10	INA	VW	631, 632, 633, 634, 635
529 0009 10	INA	NISSAN	386, 387, 388	529 0169 10	INA	MERCEDES-BENZ	369, 370, 371
529 0009 10	INA	RENAULT	496, 497, 498, 499, 500, 503, 504, 505, 506, 507	529 0173 10	INA	FORD	214, 215
529 0010 30	INA	OPEL	411	529 0174 10	INA	RENAULT	495
529 0010 30	INA	VAUXHALL	571	529 0178 10	INA	RENAULT	496, 497, 498, 499, 500
529 0012 10	INA	CITROËN	116, 118	529 0179 10	INA	FIAT	145, 146
529 0013 10	INA	FIAT	140, 141, 147, 177, 178	529 0184 10	INA	PEUGEOT	479
529 0013 10	INA	OPEL	416	529 0186 10	INA	CITROËN	116, 118
529 0013 10	INA	VAUXHALL	575	529 0187 10	INA	RENAULT	503
529 0015 10	INA	RENAULT	497, 499	529 0194 10	INA	RENAULT	503
529 0017 10	INA	FIAT	182	529 0208 10	INA	VW	631
529 0017 10	INA	PEUGEOT	494	529 0213 10	INA	FORD	186, 187
529 0034 10	INA	MERCEDES-BENZ	310, 311, 334, 340, 356, 372	529 0214 10	INA	PEUGEOT	478
529 0035 10	INA	MERCEDES-BENZ	368, 369, 370, 371, 372	529 0216 10	INA	CITROËN	114, 115, 124
529 0037 10	INA	FORD	214, 215	529 0216 10	INA	PEUGEOT	482
529 0039 30	INA	VW	615, 616	529 0224 10	INA	NISSAN	386, 387, 388
529 0046 10	INA	CITROËN	116, 118, 119	529 0224 10	INA	RENAULT	496, 497, 499
529 0046 10	INA	FIAT	178	529 0240 10	INA	VW	645, 646, 648, 649, 650, 651, 658, 659, 661, 662, 663, 666, 667, 668, 670, 671, 672, 673, 674, 675, 676
529 0046 10	INA	PEUGEOT	474, 475, 483, 484, 485, 486, 487, 488	529 0244 10	INA	VW	641
529 0050 10	INA	MERCEDES-BENZ	296, 309, 329, 330, 331, 338, 339, 353, 354, 355	529 0246 10	INA	MERCEDES-BENZ	373
529 0061 10	INA	CITROËN	124	529 0246 10	INA	NISSAN	388, 389
529 0062 10	INA	CITROËN	124	529 0246 10	INA	OPEL	460, 461, 462
529 0065 10	INA	CITROËN	124	529 0246 10	INA	RENAULT	559, 560, 561, 562, 563
529 0066 10	INA	CITROËN	124	529 0246 10	INA	VAUXHALL	614
529 0092 10	INA	PEUGEOT	494	529 0247 10	INA	OPEL	460, 461, 462, 463
529 0100 10	INA	RENAULT	495	529 0247 10	INA	RENAULT	559, 560, 561, 562, 563
529 0104 10	INA	FORD	188, 189	529 0247 10	INA	VAUXHALL	614, 615
529 0105 10	INA	FIAT	179, 180	529 0261 10	INA	CITROËN	117, 119, 120, 121, 122, 124, 125, 126
529 0105 10	INA	PEUGEOT	476, 478	529 0261 10	INA	FORD	185, 186, 187
529 0107 10	INA	PEUGEOT	493	529 0261 10	INA	PEUGEOT	485, 486, 487, 488, 489, 491
529 0109 10	INA	CITROËN	114, 115	529 0266 10	INA	CITROËN	122, 126
529 0109 10	INA	PEUGEOT	482	529 0266 10	INA	PEUGEOT	489, 492
529 0115 10	INA	MERCEDES-BENZ	297, 298, 299, 300, 303, 305, 312, 313, 314, 315, 317, 320, 321, 336, 341, 343, 357, 358, 359, 360, 361, 362, 363, 364, 366	529 0267 10	INA	CITROËN	138
529 0117 10	INA	NISSAN	387	529 0267 10	INA	FIAT	174, 175
529 0118 10	INA	NISSAN	404, 405, 407	529 0267 10	INA	PEUGEOT	472, 473, 474
529 0118 10	INA	OPEL	418, 422, 444, 445, 447, 455, 458	529 0272 10	INA	NISSAN	388
529 0118 10	INA	RENAULT	543, 544, 545, 549, 550, 554, 555	529 0278 10	INA	NISSAN	377
				529 0280 10	INA	RENAULT	495
				529 0281 10	INA	FORD	216
				529 0285 10	INA	FIAT	176
				529 0286 10	INA	FIAT	145, 146, 176
				529 0291 10	INA	PEUGEOT	477, 479
				529 0292 10	INA	PEUGEOT	480, 481
				529 0296 10	INA	OPEL	411
				529 0296 10	INA	VAUXHALL	571
				529 0298 10	INA	FORD	184, 185, 187
				529 0301 10	INA	CITROËN	135, 136, 137
				529 0301 10	INA	FIAT	166
				529 0301 10	INA	FORD	194, 196, 197, 199, 200, 201, 202
				529 0301 10	INA	PEUGEOT	470, 471, 472
				529 0301 30	INA	CITROËN	135, 136, 137, 138





*Unique LCV Application

**Numerische Liste / Numerical listing / Liste numérique / Listado numérico / Elenco numerico /
Listy numerycznej / Перечень артикулов**

SCHAEFFLER				SCHAEFFLER				
529 0301 30	INA	FIAT		166	529 0397 10	INA	FORD	202, 203
529 0301 30	INA	FORD	194, 196, 197, 199, 200, 201, 202		529 0404 10	INA	CITROËN	116, 118, 119
529 0301 30	INA	PEUGEOT		470, 471, 472	529 0404 10	INA	FIAT	178, 179
529 0308 10	INA	CITROËN		122, 126	529 0404 10	INA	PEUGEOT	474, 475, 483, 484, 485, 486, 487, 488
529 0308 10	INA	PEUGEOT		489, 492	529 0427 10	INA	NISSAN	377, 402, 404, 405, 406, 407, 408
529 0310 10	INA	CITROËN		134, 135	529 0427 10	INA	OPEL	418, 422, 444, 445, 450, 455
529 0310 10	INA	PEUGEOT		469	529 0427 10	INA	RENAULT	508, 515, 543, 544, 545, 546, 549, 550, 551, 554, 555, 557
529 0316 10	INA	RENAULT		503	529 0427 10	INA	VAUXHALL	580, 585, 598, 603, 604, 609
529 0317 10	INA	NISSAN	390, 391, 392, 393, 396, 397, 398, 406		529 0428 10	INA	NISSAN	380, 383, 384, 403, 409, 410
529 0317 10	INA	OPEL	433, 434, 435, 437, 438, 439, 440, 441, 443, 446, 451, 457		529 0428 10	INA	RENAULT	510, 511, 512, 515, 516, 518, 519, 523, 524, 546, 548, 552, 553, 557, 559
529 0317 10	INA	RENAULT	526, 527, 528, 529, 530, 532, 533, 535, 536, 537, 538, 539, 545, 551, 556		529 0429 10	INA	VW	618, 619, 624
529 0317 10	INA	VAUXHALL	589, 590, 591, 595, 599, 605, 610		529 0432 10	INA	NISSAN	378, 381, 382
529 0322 10	INA	FORD	194, 195, 197, 198, 200, 201, 202		529 0432 10	INA	OPEL	419, 420, 424, 426, 428, 429, 431
529 0324 10	INA	OPEL		411	529 0432 10	INA	RENAULT	509, 511, 517, 520, 522
529 0324 10	INA	VAUXHALL		571	529 0432 10	INA	VAUXHALL	576, 577, 581, 586
529 0333 10	INA	MERCEDES-BENZ		291, 292, 295	529 0436 10	INA	NISSAN	377, 378, 379, 381, 382, 403, 408
529 0335 10	INA	CITROËN		117, 123, 127	529 0436 10	INA	OPEL	419, 420, 424, 426, 428, 429, 431, 448, 454, 459
529 0335 10	INA	PEUGEOT	480, 481, 485, 490, 492, 494		529 0436 10	INA	RENAULT	509, 510, 511, 517, 520, 521, 522, 547, 548, 553, 558
529 0337 10	INA	FORD		183, 186	529 0436 10	INA	VAUXHALL	576, 577, 582, 586, 602, 608, 612
529 0338 10	INA	FORD		183, 186	529 0437 10	INA	NISSAN	380, 383, 384, 385, 403, 409, 410
529 0345 10	INA	OPEL		413, 414	529 0437 10	INA	OPEL	419, 423, 425, 427, 430, 447, 449, 453, 458
529 0345 10	INA	VAUXHALL		573	529 0437 10	INA	RENAULT	510, 511, 512, 515, 516, 518, 519, 523, 524, 546, 548, 552, 553, 557, 559
529 0346 10	INA	FIAT		176	529 0437 10	INA	VAUXHALL	576, 578, 581, 582, 583, 585, 587, 601, 603, 607, 608, 612, 613
529 0346 10	INA	OPEL		410, 411	529 0442 10	INA	FORD	194, 195, 197, 198, 200, 201, 202, 211, 212, 213
529 0346 10	INA	VAUXHALL		569, 570	529 0463 10	INA	FORD	214, 215
529 0352 10	INA	NISSAN		391, 398, 399	529 0467 10	INA	VW	636, 637
529 0352 10	INA	OPEL	433, 436, 439, 440, 443		530 0004 10	INA	OPEL	412
529 0352 10	INA	RENAULT	527, 528, 531, 536, 537, 539, 540		530 0004 10	INA	VAUXHALL	571, 572
529 0352 10	INA	VAUXHALL		589, 590, 591, 592	530 0004 31	INA	OPEL	412
529 0353 10	INA	NISSAN	390, 391, 392, 393, 396, 397, 398, 399		530 0004 31	INA	VAUXHALL	571, 572
529 0353 10	INA	OPEL	433, 434, 435, 436, 437, 438, 439, 440, 441, 443		530 0016 10	INA	PEUGEOT	482
529 0353 10	INA	RENAULT	526, 527, 528, 529, 530, 531, 532, 533, 535, 536, 537, 538, 539, 540		530 0016 30	INA	PEUGEOT	482
529 0353 10	INA	VAUXHALL		589, 590, 591, 592, 595	530 0062 10	INA	VW	641
529 0354 10	INA	NISSAN		394, 395	530 0066 10	INA	FORD	215, 216
529 0354 10	INA	OPEL	434, 435, 436, 439, 441, 442		530 0089 10	INA	VW	616
529 0354 10	INA	RENAULT		533, 534, 535, 541	530 0089 31	INA	VW	616
529 0354 10	INA	VAUXHALL		593, 595, 596	530 0109 10	INA	HYUNDAI	221
529 0355 10	INA	NISSAN		394, 395, 397	530 0111 10	INA	CITROËN	127, 128
529 0355 10	INA	OPEL	434, 435, 436, 438, 439, 440, 441, 442, 443		530 0111 10	INA	FIAT	151, 152, 154, 155
529 0355 10	INA	RENAULT		533, 534, 535, 540, 541, 542	530 0111 10	INA	PEUGEOT	463, 464
529 0355 10	INA	VAUXHALL		593, 594, 595, 597	530 0111 30	INA	CITROËN	127, 128
529 0356 10	INA	NISSAN		394, 395	530 0111 30	INA	FIAT	151, 152, 154, 155
529 0356 10	INA	OPEL	434, 435, 436, 438, 439, 440, 441, 442, 443		530 0111 30	INA	PEUGEOT	463, 464
529 0356 10	INA	RENAULT		533, 534, 535, 537, 540, 541, 542	530 0112 10	INA	IVECO	225, 226, 229, 232
529 0356 10	INA	VAUXHALL		593, 594, 595, 596, 597	530 0113 10	INA	FIAT	160, 161
529 0360 10	INA	PEUGEOT		480, 481	530 0117 10	INA	CITROËN	131, 132, 133, 134
529 0361 10	INA	MERCEDES-BENZ	298, 302, 303, 307, 313, 316, 318, 319, 324, 325, 337, 342, 345, 346, 347, 350, 351, 360, 364, 365, 367, 368		530 0117 10	INA	FIAT	153, 154, 161, 162, 163, 164, 165
529 0364 10	INA	FORD	203, 204, 205, 206, 207, 208		530 0117 10	INA	IVECO	224, 228, 231, 232, 234, 235
529 0364 30	INA	FORD	203, 204, 205, 206, 207, 208		530 0117 10	INA	PEUGEOT	467, 468
529 0380 10	INA	FIAT		139, 177	530 0142 10	INA	FORD	214, 215
529 0380 10	INA	OPEL		415	530 0171 10	INA	VW	618, 619, 623, 646, 659
529 0380 10	INA	VAUXHALL		574	530 0171 30	INA	VW	623
529 0383 10	INA	FIAT	166, 167, 168, 169, 170, 171, 172, 173, 174		530 0171 31	INA	VW	618, 619, 646, 659
529 0385 10	INA	FORD		216	530 0173 10	INA	VW	641
529 0388 10	INA	FORD	203, 204, 205, 206, 207, 208		530 0173 30	INA	VW	641
529 0388 30	INA	FORD	203, 204, 205, 206, 207, 208		530 0182 10	INA	RENAULT	495
529 0389 10	INA	FORD	191, 192, 193		530 0182 30	INA	RENAULT	495
529 0390 10	INA	FORD	191, 192, 193		530 0191 31	INA	RENAULT	507
529 0396 10	INA	RENAULT	496, 497, 498, 499, 500		530 0194 10	INA	RENAULT	501, 502
					530 0195 10	INA	RENAULT	495
					530 0195 30	INA	RENAULT	495
					530 0196 10	INA	NISSAN	377, 401, 402, 404, 405, 406
					530 0196 10	INA	OPEL	418, 422, 444, 450, 455





*Unique LCV Application

Numerische Liste / Numerical listing / Liste numérique / Listado numérico / Elenco numerico / Listy numerycznej / Перечень артикулов

SCHAEFFLER				SCHAEFFLER			
530 0196 10	INA	RENAULT	508, 515, 543, 544, 549, 550, 554, 555	530 0357 10	INA	RENAULT	501, 502
530 0196 10	INA	VAUXHALL	580, 585, 598, 603, 604, 609	530 0368 10	INA	CITROËN	130
530 0196 30	INA	NISSAN	377, 404, 405, 406	530 0368 10	INA	PEUGEOT	466
530 0196 30	INA	OPEL	418, 422, 444, 450, 455	530 0368 30	INA	CITROËN	130
530 0196 30	INA	RENAULT	508, 515, 543, 544, 549, 550, 554, 555	530 0368 30	INA	PEUGEOT	466
530 0196 30	INA	VAUXHALL	580, 585, 598, 603, 604, 609	530 0375 10	INA	CITROËN	116, 118, 119, 124
530 0197 10	INA	NISSAN	386, 387	530 0375 10	INA	FIAT	178
530 0197 10	INA	RENAULT	496, 497, 498, 499, 503, 504, 505, 506	530 0375 10	INA	PEUGEOT	474, 483, 484, 485, 486, 487, 488, 491
530 0197 30	INA	NISSAN	386	530 0375 30	INA	CITROËN	116, 118, 119, 124
530 0197 30	INA	RENAULT	496, 497, 499	530 0375 30	INA	FIAT	178
530 0197 31	INA	NISSAN	386, 387	530 0375 30	INA	PEUGEOT	474, 483, 484, 485, 486, 487, 488, 491
530 0197 31	INA	RENAULT	496, 497, 498, 499, 503, 504, 505, 506	530 0379 10	INA	CITROËN	118, 123, 124
530 0197 32	INA	NISSAN	386, 387, 388	530 0379 10	INA	PEUGEOT	486, 490
530 0197 32	INA	RENAULT	504, 505	530 0379 30	INA	CITROËN	118, 123, 124
530 0198 10	INA	NISSAN	377, 378, 379, 380, 381, 382, 383, 384, 385, 403, 408, 409	530 0379 30	INA	PEUGEOT	486, 490
530 0198 10	INA	OPEL	419, 420, 423, 424, 425, 426, 427, 428, 429, 430, 431, 447, 448, 449, 453, 454, 458, 459	530 0425 10	INA	HYUNDAI	217
530 0198 10	INA	RENAULT	509, 510, 511, 512, 515, 516, 517, 518, 519, 520, 521, 522, 523, 524, 546, 547, 548, 552, 553, 557, 558, 559	530 0440 10	INA	PEUGEOT	493
530 0198 10	INA	VAUXHALL	576, 577, 578, 581, 582, 583, 585, 586, 587, 601, 602, 607, 608, 612, 613	530 0440 30	INA	PEUGEOT	493
530 0201 10	INA	VW	619, 620, 621, 622, 625, 642, 643, 644, 656, 657, 658	530 0441 10	INA	OPEL	412, 413
530 0201 32	INA	VW	625	530 0441 10	INA	VAUXHALL	570, 572
530 0201 33	INA	VW	619, 620, 621, 622, 642, 643, 644, 656, 657, 658	530 0441 30	INA	OPEL	412, 413
530 0206 10	INA	FIAT	144	530 0441 30	INA	VAUXHALL	570, 572
530 0206 30	INA	FIAT	144	530 0441 32	INA	VAUXHALL	570
530 0222 10	INA	FIAT	147, 148	530 0447 10	INA	CITROËN	130
530 0228 10	INA	FIAT	140, 141	530 0447 10	INA	PEUGEOT	466
530 0228 10	INA	OPEL	416	530 0447 30	INA	CITROËN	130
530 0228 10	INA	VAUXHALL	575	530 0447 30	INA	PEUGEOT	466
530 0228 30	INA	FIAT	140, 141	530 0449 10	INA	FIAT	179, 180
530 0228 30	INA	OPEL	416	530 0449 10	INA	PEUGEOT	476, 478
530 0228 30	INA	VAUXHALL	575	530 0449 30	INA	FIAT	179, 180
530 0232 10	INA	FIAT	158, 159, 167, 168, 169, 170, 171, 172, 173, 174	530 0462 10	INA	FIAT	144, 147, 177, 178
530 0232 10	INA	IVECO	222, 223, 224, 225, 226, 227, 228, 230, 232, 236, 237, 238, 239, 240, 241, 242, 243, 244, 250, 252, 253, 254, 255, 276, 277, 278, 282, 283, 284	530 0462 30	INA	FIAT	147, 177, 178
530 0232 30	INA	FIAT	156, 158, 159, 167, 168, 169, 170, 171, 172, 173	530 0470 10	INA	FIAT	182
530 0232 30	INA	IVECO	222, 223, 224, 225, 226, 227, 228, 230, 232, 236, 237, 238, 239, 240, 241, 242, 243, 244, 250, 252, 253, 254, 276, 277, 278, 282, 283, 284	530 0470 10	INA	PEUGEOT	494
530 0233 10	INA	CITROËN	129	530 0470 30	INA	FIAT	182
530 0233 10	INA	FIAT	156, 157, 158	530 0470 30	INA	PEUGEOT	494
530 0233 10	INA	PEUGEOT	465	530 0471 10	INA	PEUGEOT	478
530 0237 10	INA	CITROËN	124	530 0471 10	INA	PEUGEOT	478
530 0237 30	INA	CITROËN	124	530 0471 30	INA	PEUGEOT	478
530 0238 10	INA	PEUGEOT	479	530 0473 10	INA	RENAULT	501, 502
530 0238 30	INA	PEUGEOT	479	530 0482 10	INA	VW	639, 640
530 0298 10	INA	MITSUBISHI	376	530 0482 30	INA	VW	639, 640
530 0300 10	INA	HYUNDAI	217	530 0483 10	INA	VW	641
530 0303 10	INA	MITSUBISHI	376	530 0483 30	INA	VW	641
530 0335 10	INA	CITROËN	114, 115	530 0490 10	INA	RENAULT	506
530 0335 10	INA	FIAT	177	530 0492 10	INA	OPEL	413, 414
530 0335 10	INA	PEUGEOT	482	530 0492 10	INA	VAUXHALL	573
530 0335 30	INA	CITROËN	114, 115	530 0494 10	INA	OPEL	413, 414
530 0335 30	INA	FIAT	177	530 0494 10	INA	VAUXHALL	573
530 0335 30	INA	PEUGEOT	482	530 0512 10	INA	TOYOTA	563, 564, 565, 566, 567, 568, 569
530 0357 10	INA	RENAULT	508, 515, 543, 544, 549, 550, 554, 555	530 0538 10	INA	VW	617
530 0357 10	INA	VAUXHALL	580, 585, 598, 603, 604, 609	530 0538 30	INA	VW	617
530 0357 30	INA	NISSAN	377, 404, 405, 406	530 0549 10	INA	HYUNDAI	217
530 0357 30	INA	OPEL	418, 422, 444, 450, 455	530 0550 10	INA	VW	617, 619, 622, 623, 624, 625, 626, 627, 630, 632, 633, 634, 636, 637, 638, 639, 645, 646, 647, 648, 649, 650, 651, 658, 659, 660, 661, 662, 663, 666, 667, 668, 670, 671, 672, 673, 674, 675, 676
530 0357 30	INA	RENAULT	508, 515, 543, 544, 549, 550, 554, 555	530 0550 32	INA	VW	617, 619, 622, 623, 624, 625, 626, 627, 630, 632, 633, 634, 636, 637, 638, 639, 645, 646, 647, 648, 649, 650, 651, 658, 659, 660, 661, 662, 663, 666, 667, 668, 670, 671, 672, 673, 674, 675, 676
530 0375 10	INA	VAUXHALL	580, 585, 598, 603, 604, 609	530 0558 10	INA	FIAT	180, 181
530 0375 10	INA	NISSAN	386, 387	530 0558 10	INA	PEUGEOT	477, 478
530 0375 10	INA	RENAULT	496, 497, 498, 499, 503, 504, 505, 506	530 0558 31	INA	FIAT	180, 181
530 0375 30	INA	NISSAN	386	530 0558 31	INA	PEUGEOT	477, 478
530 0375 30	INA	RENAULT	496, 497, 499	530 0561 10	INA	FIAT	142, 143
530 0379 10	INA	NISSAN	386, 387				
530 0379 10	INA	RENAULT	496, 497, 498, 499, 503, 504, 505, 506				
530 0379 30	INA	NISSAN	386				
530 0379 30	INA	RENAULT	496, 497, 499				
530 0425 10	INA	HYUNDAI	217				
530 0440 10	INA	PEUGEOT	493				
530 0440 30	INA	PEUGEOT	493				
530 0441 10	INA	OPEL	412, 413				
530 0441 10	INA	VAUXHALL	570, 572				
530 0441 30	INA	OPEL	412, 413				
530 0441 30	INA	VAUXHALL	570, 572				
530 0441 32	INA	VAUXHALL	570				
530 0447 10	INA	CITROËN	130				
530 0447 10	INA	PEUGEOT	466				
530 0447 30	INA	CITROËN	130				
530 0447 30	INA	PEUGEOT	466				
530 0449 10	INA	FIAT	179, 180				
530 0449 10	INA	PEUGEOT	476, 478				
530 0449 30	INA	FIAT	179, 180				
530 0449 30	INA	PEUGEOT	476, 478				
530 0462 10	INA	FIAT	144, 147, 177, 178				
530 0462 30	INA	FIAT	147, 177, 178				
530 0470 10	INA	FIAT	182				
530 0470 10	INA	PEUGEOT	494				
530 0470 30	INA	FIAT	182				
530 0470 30	INA	PEUGEOT	494				
530 0471 10	INA	PEUGEOT	478				
530 0471 10	INA	PEUGEOT	478				
530 0471 30	INA	RENAULT	501, 502				
530 0482 10	INA	VW	639, 640				
530 0482 30	INA	VW	639, 640				
530 0483 10	INA	VW	641				
530 0483 30	INA	VW	641				
530 0490 10	INA	RENAULT	506				
530 0492 10	INA	OPEL	413, 414				
530 0492 10	INA	VAUXHALL	573				
530 0494 10	INA	OPEL	413, 414				
530 0494 10	INA	VAUXHALL	573				
530 0512 10	INA	TOYOTA	563, 564, 565, 566, 567, 568, 569				
530 0538 10	INA	VW	617				
530 0538 30	INA	VW	617				
530 0549 10	INA	HYUNDAI	217				
530 0550 10	INA	VW	617, 619, 622, 623, 624, 625, 626, 627, 630, 632, 633, 634, 636, 637, 638, 639, 645, 646, 647, 648, 649, 650, 651, 658, 659, 660, 661, 662, 663, 666, 667, 668, 670, 671, 672, 673, 674, 675, 676				
530 0550 32	INA	VW	617, 619, 622, 623, 624, 625, 626, 627, 630, 632, 633, 634, 636, 637, 638, 639, 645, 646, 647, 648, 649, 650, 651, 658, 659, 660, 661, 662, 663, 666, 667, 668, 670, 671, 672, 673, 674, 675, 676				
530 0558 10	INA	FIAT	180, 181				
530 0558 10	INA	PEUGEOT	477, 478				
530 0558 31	INA	FIAT	180, 181				
530 0558 31	INA	PEUGEOT	477, 478				
530 0561 10	INA	FIAT	142, 143				





*Unique LCV Application

**Numerische Liste / Numerical listing / Liste numérique / Listado numérico / Elenco numerico /
Listy numerycznej / Перечень артикулов**

SCHAEFFLER				SCHAEFFLER				
530 0561 10	INA	OPEL		416, 417	531 0096 10	INA	PEUGEOT	465
530 0561 10	INA	VAUXHALL		575	531 0101 30	INA	OPEL	412
530 0561 30	INA	FIAT		142, 143	531 0101 30	INA	VAUXHALL	571, 572
530 0561 30	INA	OPEL		416, 417	531 0121 20	INA	MITSUBISHI	376
530 0561 30	INA	VAUXHALL		575	531 0124 20	INA	HYUNDAI	217
530 0562 10	INA	FIAT		144, 165	531 0148 10	INA	PEUGEOT	494
530 0562 10	INA	OPEL		417	531 0193 20	INA	MITSUBISHI	376
530 0562 10	INA	VAUXHALL		575	531 0203 20	INA	VW	618, 619, 623, 647, 659
530 0562 30	INA	FIAT		144, 165	531 0215 20	INA	TOYOTA	563, 564, 565, 566, 567, 568, 569
530 0562 30	INA	OPEL		417	531 0231 20	INA	HYUNDAI	221
530 0562 30	INA	VAUXHALL		575	531 0231 20	INA	MITSUBISHI	376
530 0578 10	INA	CITROËN		117, 120, 121, 122, 125	531 0232 20	INA	HYUNDAI	221
530 0578 10	INA	FIAT		178	531 0241 10	INA	CITROËN	114, 115, 124
530 0578 10	INA	PEUGEOT		475, 484, 487, 488, 489, 491	531 0241 10	INA	PEUGEOT	482, 486
530 0578 30	INA	CITROËN		117, 120, 121, 122, 125	531 0263 10	INA	PEUGEOT	493
530 0578 30	INA	FIAT		178	531 0264 10	INA	CITROËN	127, 128, 130
530 0578 30	INA	PEUGEOT		475, 484, 487, 488, 489, 491	531 0264 10	INA	FIAT	151, 152, 154, 155
530 0592 10	INA	VW		628, 629, 631	531 0264 10	INA	PEUGEOT	463, 464, 466
530 0594 10	INA	MITSUBISHI		376	531 0274 30	INA	VW	641
530 0601 10	INA	CITROËN		131, 132, 133, 134	531 0276 30	INA	VW	641
530 0601 10	INA	FIAT		153, 154, 161, 162, 163, 164, 165	531 0280 10	INA	FIAT	147, 148
530 0601 10	INA	IVECO		224, 228, 231, 232, 234, 235	531 0317 10	INA	VW	616, 617
530 0601 10	INA	PEUGEOT		467, 468	531 0339 10	INA	VW	616, 617
530 0602 10	INA	IVECO		225, 226, 229, 232	531 0342 30	INA	VW	639, 640
530 0603 10	INA	FIAT		160, 161	531 0343 30	INA	VW	641
530 0604 10	INA	RENAULT		506	531 0345 10	INA	FORD	215, 216
530 0604 30	INA	RENAULT		507	531 0373 10	INA	CITROËN	127, 128, 130
530 0605 10	INA	FORD		186	531 0373 10	INA	FIAT	151, 152, 154, 155
530 0605 30	INA	FORD		186	531 0373 10	INA	PEUGEOT	463, 464, 466
530 0607 10	INA	NISSAN		386, 387	531 0382 20	INA	HYUNDAI	217
530 0607 10	INA	RENAULT		504, 505, 506	531 0404 10	INA	RENAULT	495
530 0607 30	INA	NISSAN		386, 387, 388	531 0408 30	INA	RENAULT	502
530 0607 30	INA	RENAULT		504, 505, 506	531 0409 30	INA	RENAULT	500, 501, 507
530 0611 10	INA	FORD		185, 186, 187	531 0414 30	INA	FIAT	140, 141
530 0611 30	INA	FORD		186, 187	531 0414 30	INA	OPEL	416
530 0612 10	INA	CITROËN		117, 120, 121, 122, 125	531 0414 30	INA	VAUXHALL	575
530 0612 10	INA	FORD		185	531 0478 10	INA	CITROËN	124
530 0612 10	INA	PEUGEOT		475, 484, 487, 488, 489, 491	531 0480 10	INA	IVECO	224, 225, 226, 228, 229, 231, 232, 233, 234, 235
530 0612 30	INA	CITROËN		117, 120, 121, 122, 125	531 0497 10	INA	FORD	214, 215
530 0612 30	INA	FORD		185	531 0505 10	INA	FIAT	158, 159, 167, 168, 169, 170, 171, 172, 173
530 0612 30	INA	PEUGEOT		475, 484, 487, 488, 489, 491	531 0505 10	INA	IVECO	222, 223, 224, 225, 226, 227, 228, 230, 232, 236, 237, 238, 239, 240, 241, 242, 243, 244, 250, 252, 253, 254, 255, 276, 277, 278, 282, 283, 284
530 0638 10	INA	OPEL		446, 447, 452, 453, 457, 458	531 0518 30	INA	OPEL	412, 413
530 0638 10	INA	VAUXHALL		600, 601, 606, 611	531 0518 30	INA	VAUXHALL	570, 572
530 0638 30	INA	OPEL		446, 447, 452, 453, 457, 458	531 0536 10	INA	VW	655, 656, 665, 666
530 0638 30	INA	VAUXHALL		600, 601, 606, 611	531 0546 10	INA	PEUGEOT	479
530 0640 10	INA	RENAULT		500, 501, 507	531 0547 10	INA	NISSAN	386, 387, 388
530 0640 30	INA	RENAULT		500, 501, 507	531 0547 10	INA	RENAULT	496, 497, 498, 499, 500, 503, 504, 505, 506
530 0650 10	INA	MAN		289, 290	531 0548 10	INA	NISSAN	377, 378, 379, 380, 381, 382, 383, 384, 385, 403, 408, 409
530 0650 10	INA	VW		631, 632, 633, 634, 635, 636, 677	531 0548 10	INA	OPEL	419, 420, 423, 424, 425, 426, 427, 428, 429, 430, 431, 447, 448, 449, 453, 454, 458, 459
530 0650 30	INA	VW		631, 632, 633, 634, 635, 677	531 0548 10	INA	RENAULT	509, 510, 511, 512, 515, 516, 517, 518, 519, 520, 521, 522, 523, 524, 546, 547, 548, 552, 553, 557, 558, 559
530 0691 10	INA	CITROËN		134, 135	531 0548 10	INA	VAUXHALL	576, 577, 578, 581, 582, 583, 585, 586, 587, 601, 602, 607, 608, 612, 613
530 0691 10	INA	PEUGEOT		469, 480, 481	531 0551 20	INA	MERCEDES-BENZ	294
530 0691 30	INA	CITROËN		134, 135	531 0555 10	INA	CITROËN	116, 118, 119, 124
530 0691 30	INA	PEUGEOT		469, 480, 481	531 0555 10	INA	FIAT	178
530 0698 10	INA	CITROËN		117, 123, 126, 127	531 0555 10	INA	PEUGEOT	474, 483, 484, 485, 486, 487, 488, 491
530 0698 10	INA	FORD		184, 186, 187	531 0557 10	INA	CITROËN	131, 132, 133, 134
530 0698 10	INA	PEUGEOT		480, 481, 484, 490, 492, 494	531 0557 10	INA	FIAT	153, 154, 161, 162, 163, 164, 165
530 0698 30	INA	CITROËN		117, 123, 126, 127				
530 0698 30	INA	FORD		184, 186, 187				
530 0698 30	INA	PEUGEOT		480, 481, 484, 490, 492, 494				
530 0700 10	INA	FORD		183, 186				
530 0719 10	INA	TOYOTA		563, 564, 565, 566, 567, 568, 569				
531 0005 10	INA	FIAT		144				
531 0030 10	INA	PEUGEOT		482				
531 0047 10	INA	CITROËN		129				
531 0047 10	INA	FIAT		156, 157, 158				
531 0047 10	INA	PEUGEOT		465				
531 0055 10	INA	RENAULT		495				
531 0096 10	INA	CITROËN		129				
531 0096 10	INA	FIAT		156, 157, 158				





*Unique LCV Application

Numerische Liste / Numerical listing / Liste numérique / Listado numérico / Elenco numerico / Listy numerycznej / Перечень артикулов

SCHAEFFLER				SCHAEFFLER			
531 0557 10	INA	IVECO	224, 228, 231, 232, 234, 235	531 0894 10	INA	VW	631, 632, 633, 634, 635, 636, 677
531 0557 10	INA	PEUGEOT	467, 468	531 0906 10	INA	NISSAN	386, 387, 388
531 0565 30	INA	VW	620, 621, 622, 625, 642, 643, 644, 656, 657, 658	531 0906 10	INA	RENAULT	504, 505, 506
531 0572 10	INA	CITROËN	114, 115	531 0931 10	INA	NISSAN	376, 377, 386
531 0572 10	INA	FIAT	177	532 0033 10	INA	OPEL	412, 413
531 0572 10	INA	PEUGEOT	482	532 0033 10	INA	VAUXHALL	570, 572
531 0591 30	INA	RENAULT	496, 497, 498, 499, 500	532 0074 20	INA	HYUNDAI	217
531 0630 30	INA	OPEL	446, 447, 452, 453, 457, 458	532 0074 20	INA	NISSAN	376
531 0630 30	INA	VAUXHALL	600, 601, 606, 611	532 0108 10	INA	MERCEDES-BENZ	291, 292, 295, 296, 298, 299, 300, 302, 303, 307, 310, 311, 313, 314, 315, 316, 318, 319, 324, 325, 326, 334, 335, 336, 337, 340, 342, 343, 344, 345, 346, 347, 350, 351, 356, 357, 358, 359, 360, 361, 362, 363, 364, 365, 366, 367, 368, 373, 374, 375
531 0632 10	INA	CITROËN	119, 123, 124	532 0111 10	INA	VW	639, 640
531 0632 10	INA	PEUGEOT	486, 490	532 0142 10	INA	CITROËN	124
531 0651 20	INA	HYUNDAI	217	532 0143 10	INA	FIAT	182
531 0744 10	INA	RENAULT	495	532 0160 10	INA	MERCEDES-BENZ	291, 292, 295, 296, 297, 299, 300, 301, 303, 304, 305, 310, 311, 312, 313, 314, 315, 316, 317, 320, 321, 322, 323, 334, 335, 336, 337, 340, 341, 342, 343, 344, 345, 348, 349, 356, 357, 358, 359, 360, 361, 362, 363, 364, 366, 368, 369, 370, 371, 372
531 0749 10	INA	CITROËN	131, 132, 133, 134	532 0161 10	INA	MAN	289, 290
531 0749 10	INA	FIAT	153, 154, 160, 161, 162, 163, 164, 165	532 0161 10	INA	VW	617, 619, 622, 623, 624, 625, 626, 627, 630, 631, 632, 633, 634, 635, 636, 637, 638, 639, 640, 645, 646, 647, 648, 649, 650, 651, 658, 659, 660, 661, 662, 663, 666, 667, 668, 669, 670, 671, 672, 673, 674, 675, 676, 677
531 0749 10	INA	PEUGEOT	467, 468	532 0167 10	INA	VW	616, 617
531 0756 10	INA	FIAT	179, 180	532 0169 10	INA	VW	641
531 0756 10	INA	PEUGEOT	476, 478	532 0185 10	INA	VW	616
531 0759 10	INA	GAZ	216, 217	532 0187 10	INA	FORD	216
531 0760 10	INA	FIAT	147, 148	532 0196 10	INA	CITROËN	127, 128, 130
531 0761 10	INA	RENAULT	502	532 0196 10	INA	FIAT	151, 152, 154, 155
531 0769 10	INA	CITROËN	130	532 0196 10	INA	PEUGEOT	463, 464, 466
531 0769 10	INA	PEUGEOT	466	532 0209 10	INA	FIAT	147, 148
531 0770 10	INA	PEUGEOT	478	532 0220 10	INA	RENAULT	502
531 0778 10	INA	FIAT	144, 147, 177, 178	532 0222 10	INA	RENAULT	502
531 0780 10	INA	FIAT	182	532 0234 10	INA	MERCEDES-BENZ	296, 308, 309, 328, 329, 330, 331, 332, 333, 338, 339, 352, 353, 354, 355, 369, 370, 371
531 0780 10	INA	PEUGEOT	493, 494	532 0239 20	INA	CITROËN	131, 132, 133, 134
531 0812 10	INA	CITROËN	131, 132, 133, 134, 138	532 0239 20	INA	FIAT	153, 154, 160, 161, 162, 163, 164, 165
531 0812 10	INA	FIAT	153, 154, 161, 162, 163, 174, 175	532 0239 20	INA	FIAT	153, 154, 160, 161, 162, 163, 164, 165
531 0812 10	INA	IVECO	228, 229, 232, 233, 234, 235, 236, 244, 245, 246, 247, 248, 249, 250, 251, 255, 256, 257, 258, 259, 260, 261, 262, 263, 264, 265, 266, 267, 268, 269, 270, 271, 272, 273, 274, 275, 279, 280	532 0239 20	INA	IVECO	224, 225, 226, 228, 229, 231, 232, 234, 235
531 0812 10	INA	PEUGEOT	467, 468, 469, 472, 473, 474	532 0239 20	INA	IVECO	224, 225, 226, 228, 229, 231, 232, 234, 235
531 0818 10	INA	RENAULT	507	532 0239 20	INA	PEUGEOT	467, 468
531 0819 10	INA	OPEL	413, 414	532 0243 10	INA	NISSAN	377, 404, 405, 407
531 0819 10	INA	VAUXHALL	573	532 0243 10	INA	OPEL	418, 422, 444, 445, 447, 455, 458
531 0825 10	INA	VW	617, 619, 622, 623, 624, 625, 626, 627, 630, 632, 633, 634, 636, 637, 638, 639, 645, 646, 647, 648, 649, 650, 651, 658, 659, 660, 661, 662, 663, 666, 667, 668, 670, 671, 672, 673, 674, 675, 676	532 0243 10	INA	RENAULT	500, 501, 508, 515, 543, 544, 545, 549, 550, 554, 555
531 0829 10	INA	CITROËN	117, 123, 127	532 0243 10	INA	VAUXHALL	580, 585, 598, 601, 603, 604, 606
531 0829 10	INA	FORD	184, 186, 187	532 0260 10	INA	RENAULT	495
531 0829 10	INA	PEUGEOT	480, 481, 484, 490, 492, 494	532 0287 10	INA	FIAT	149, 150
531 0834 10	INA	NISSAN	376	532 0289 10	INA	PEUGEOT	478, 479
531 0839 10	INA	FIAT	180, 181	532 0294 10	INA	CITROËN	131, 132, 133, 134
531 0839 10	INA	PEUGEOT	477, 478	532 0294 10	INA	FIAT	153, 154, 161, 162, 163, 164, 165
531 0844 10	INA	FIAT	142, 143, 144, 149, 150, 151, 165	532 0298 10	INA	FIAT	158, 159, 167, 168, 169, 170, 171, 172, 173, 174
531 0844 10	INA	OPEL	416, 417				
531 0844 10	INA	VAUXHALL	575				
531 0850 10	INA	CITROËN	117, 120, 121, 122, 125				
531 0850 10	INA	FIAT	178				
531 0850 10	INA	PEUGEOT	475, 484, 487, 488, 489, 491				
531 0854 10	INA	RENAULT	495				
531 0866 10	INA	CITROËN	122, 126				
531 0866 10	INA	PEUGEOT	489, 492				
531 0876 10	INA	RENAULT	507				
531 0877 10	INA	FORD	186				
531 0882 10	INA	VW	628, 629, 631				
531 0883 10	INA	FORD	185, 186, 187				
531 0884 10	INA	CITROËN	117, 120, 121, 122, 125				
531 0884 10	INA	FORD	185				
531 0884 10	INA	PEUGEOT	475, 485, 487, 488, 489, 491				
531 0885 10	INA	CITROËN	134, 135				
531 0885 10	INA	PEUGEOT	469, 480, 481				
531 0894 10	INA	MAN	289, 290				





*Unique LCV Application

**Numerische Liste / Numerical listing / Liste numérique / Listado numérico / Elenco numerico /
Listy numerycznej / Перечень артикулов**

SCHAEFFLER				SCHAEFFLER			
532 0298 10	INA	IVECO	222, 223, 224, 225, 226, 227, 228, 230, 232, 236, 237, 238, 239, 240, 241, 242, 243, 244, 250, 252, 253, 254, 255, 276, 277, 278, 282, 283	532 0439 10	INA	PEUGEOT	479
				532 0441 10	INA	FIAT	158, 159, 167, 168, 169, 170, 171, 172, 173
532 0311 10	INA	FORD	214, 215	532 0441 10	INA	IVECO	222, 223, 224, 225, 226, 227, 228, 230, 232, 236, 237, 238, 239, 240, 241, 242, 243, 244, 250, 252, 253, 254, 255, 276, 277, 278, 282, 283, 284
532 0313 20	INA	NISSAN	377, 378, 379, 380, 381, 382, 383, 384, 385, 403, 408, 409, 410	532 0443 10	INA	RENAULT	502
532 0313 20	INA	OPEL	419, 420, 423, 424, 425, 426, 427, 428, 429, 430, 431, 447, 448, 449, 453, 454, 458, 459	532 0449 10	INA	FORD	191, 192, 193
532 0313 20	INA	RENAULT	509, 510, 511, 512, 515, 516, 517, 518, 519, 520, 521, 522, 523, 524, 546, 547, 548, 552, 553, 557, 558, 559	532 0460 10	INA	CITROËN	130
532 0313 20	INA	VAUXHALL	576, 577, 578, 581, 582, 583, 585, 586, 587, 601, 602, 603, 607, 608, 612, 613	532 0460 10	INA	PEUGEOT	466
532 0321 10	INA	CITROËN	116, 118, 119, 124	532 0468 10	INA	VW	636, 637, 638, 639, 645, 646, 648, 649, 650, 651, 658, 659, 660, 661, 662, 663, 666, 667, 668, 669, 670, 671, 672, 673, 674, 675, 676, 677
532 0321 10	INA	FIAT	178	532 0470 10	INA	CITROËN	135, 136, 137, 138
532 0321 10	INA	PEUGEOT	474, 483, 484, 485, 486, 487, 488, 491	532 0470 10	INA	FIAT	166
532 0322 10	INA	RENAULT	502	532 0470 10	INA	FORD	188, 189, 194, 195, 196, 197, 198, 199, 200, 201, 202, 211, 212, 213
532 0331 10	INA	CITROËN	114, 119, 123	532 0470 10	INA	PEUGEOT	470, 471, 472
532 0331 10	INA	FIAT	177	532 0471 10	INA	FORD	188, 189
532 0331 10	INA	PEUGEOT	482, 486, 490	532 0473 10	INA	CITROËN	134, 135
532 0333 10	INA	NISSAN	377	532 0473 10	INA	FIAT	179, 180, 181
532 0333 10	INA	OPEL	419, 420, 423, 424, 425, 426, 427, 428, 429, 430, 431, 444, 445, 447, 448, 449, 450, 453, 454, 455, 456, 458, 459	532 0473 10	INA	PEUGEOT	469, 476, 477, 478, 479, 480, 481
532 0333 10	INA	VAUXHALL	576, 578, 581, 582, 583, 585, 586, 587, 598, 601, 602, 603, 604, 607, 608, 609, 612, 613	532 0477 10	INA	CITROËN	135, 136, 137, 138
532 0335 10	INA	CITROËN	127, 128, 130	532 0477 10	INA	FIAT	166
532 0335 10	INA	FIAT	151, 152, 154, 155	532 0477 10	INA	FORD	188, 194, 195, 196, 197, 198, 199, 200, 201, 202, 211, 212, 213
532 0335 10	INA	PEUGEOT	463, 464, 466	532 0477 10	INA	PEUGEOT	470, 471, 472
532 0345 10	INA	FIAT	182	532 0478 10	INA	OPEL	412, 413
532 0345 10	INA	PEUGEOT	493, 494	532 0478 10	INA	VAUXHALL	570, 572
532 0349 10	INA	VW	620, 621, 622, 625, 642, 643, 644, 656, 657, 658	532 0504 10	INA	OPEL	413, 414
532 0354 10	INA	RENAULT	496, 497, 498, 499, 500, 505, 506	532 0504 10	INA	VAUXHALL	573
532 0364 20	INA	NISSAN	377, 378, 379, 380, 381, 382, 383, 384, 385, 402, 403, 405, 406, 409, 410	532 0505 10	INA	FIAT	142, 143, 144, 165
532 0364 20	INA	OPEL	418, 419, 420, 422, 423, 424, 425, 426, 427, 428, 429, 430, 431, 444, 445, 446, 447, 448, 449, 450, 452, 453, 454, 455, 456, 457, 458, 459	532 0505 10	INA	OPEL	417
532 0364 20	INA	RENAULT	509, 510, 511, 512, 515, 516, 517, 518, 519, 520, 521, 522, 523, 524, 544, 545, 546, 547, 548, 550, 552, 553, 555, 557, 558, 559	532 0505 10	INA	VAUXHALL	575
532 0364 20	INA	VAUXHALL	576, 578, 580, 581, 582, 583, 585, 586, 587, 598, 600, 601, 602, 603, 604, 606, 607, 608, 609, 611, 612, 613	532 0534 10	INA	FIAT	182, 183
532 0370 20	INA	FIAT	149, 150, 151	532 0534 10	INA	NISSAN	390, 391, 392, 393, 394, 395, 396, 397, 398, 406, 409, 410
532 0391 20	INA	MERCEDES- BENZ	291, 292, 295, 297, 299, 300, 301, 303, 304, 305, 312, 313, 314, 315, 316, 317, 320, 321, 322, 323, 341, 343, 344, 345, 348, 349, 357, 358, 359, 360, 361, 362, 363, 364, 366	532 0534 10	INA	OPEL	419, 423, 425, 427, 430, 433, 434, 435, 436, 437, 438, 439, 440, 441, 442, 443, 445, 446, 448, 449, 451, 453, 456, 457, 458, 460, 461, 462, 463
532 0395 10	INA	CITROËN	119, 123, 124	532 0534 10	INA	RENAULT	503, 509, 510, 511, 512, 515, 516, 517, 518, 519, 520, 521, 522, 523, 524, 526, 527, 528, 529, 530, 531, 532, 533, 534, 535, 536, 537, 538, 539, 540, 541, 542, 546, 548, 552, 553, 557, 559, 560, 561, 562, 563
532 0395 10	INA	PEUGEOT	486, 490	532 0534 10	INA	VAUXHALL	577, 585, 589, 590, 591, 592, 593, 594, 595, 596, 597, 599, 601, 603, 605, 607, 608, 609, 610, 612, 613, 614, 615
532 0399 20	INA	IVECO	224, 225, 226, 228, 229, 231, 232, 233, 234, 235	532 0535 10	INA	VW	639, 640
532 0401 30	INA	MERCEDES- BENZ	306, 323, 327, 349, 351	532 0536 10	INA	VW	639, 640
532 0402 30	INA	OPEL	414	532 0538 10	INA	CITROËN	116, 118, 119, 120
532 0402 30	INA	VAUXHALL	573	532 0538 10	INA	FIAT	178, 179
				532 0538 10	INA	PEUGEOT	474, 475, 483, 484, 485, 486, 487, 488
				532 0539 10	INA	MERCEDES- BENZ	310, 311, 334, 340, 356, 372
				532 0545 10	INA	FORD	216
				532 0565 10	INA	MAN	289, 290
				532 0565 10	INA	VW	635, 636
				532 0566 10	INA	MERCEDES- BENZ	296, 308, 309, 328, 329, 330, 331, 332, 333, 338, 339, 352, 353, 354, 355, 356
				532 0568 10	INA	HYUNDAI	220, 221, 222





*Unique LCV Application

Numerische Liste / Numerical listing / Liste numérique / Listado numérico / Elenco numerico / Listy numerycznej / Перечень артикулов

SCHAEFFLER				SCHAEFFLER			
532 0570 10	INA	MERCEDES-BENZ	298, 302, 303, 307, 313, 316, 318, 319, 324, 325, 326, 337, 342, 345, 346, 347, 350, 351, 360, 364, 365, 367, 368	532 0866 10	INA	MERCEDES-BENZ	310, 311, 334, 340, 356, 372
532 0571 10	INA	MERCEDES-BENZ	373, 374, 375	532 0874 10	INA	PEUGEOT	479, 494
532 0582 10	INA	VW	617, 619, 622, 623, 624, 625, 626, 627, 630, 632, 633, 634, 636, 637, 638, 639, 645, 646, 648, 649, 650, 651, 658, 659, 660, 661, 662, 663, 666, 667, 668, 670, 671, 672, 673, 674, 675, 676	532 0907 10	INA	FIAT	139, 140, 176, 177
532 0599 10	INA	MITSUBISHI	376	532 0907 10	INA	OPEL	415
532 0608 10	INA	MERCEDES-BENZ	298, 302, 303, 307, 313, 317, 318, 319, 324, 325, 326, 337, 342, 345, 346, 347, 350, 351	532 0907 10	INA	VAUXHALL	574
532 0611 10	INA	FIAT	142, 143, 144, 150, 151, 165	532 0909 10	INA	FORD	194, 195, 197, 198, 200, 201, 202, 211, 212, 213
532 0611 10	INA	OPEL	416, 417	532 0910 10	INA	FORD	188, 194, 195, 196, 197, 198, 199, 200, 201, 202, 211, 212, 213, 214
532 0611 10	INA	VAUXHALL	575	532 0912 10	INA	CITROËN	122, 126
532 0612 10	INA	FORD	214, 215	532 0912 10	INA	PEUGEOT	489, 492
532 0617 10	INA	FIAT	142, 143, 144, 165	533 0017 10	INA	MERCEDES-BENZ	291, 292, 295, 296, 297, 299, 300, 301, 303, 304, 305, 312, 313, 314, 315, 316, 317, 318, 320, 321, 322, 323, 335, 336, 337, 341, 342, 343, 344, 345, 348, 349, 357, 358, 359, 360, 361, 362, 363, 364, 366
532 0617 10	INA	OPEL	417	533 0020 10	INA	VW	641
532 0617 10	INA	VAUXHALL	575	533 0044 20	INA	HYUNDAI	217
532 0623 10	INA	MAN	289, 290	533 0044 20	INA	MITSUBISHI	376
532 0623 10	INA	VW	617, 619, 622, 623, 624, 625, 626, 627, 630, 631, 632, 633, 634, 635, 636, 637, 638, 639, 645, 646, 648, 649, 650, 651, 658, 659, 660, 661, 662, 663, 666, 667, 668, 669, 670, 671, 672, 673, 674, 675, 676, 677	533 0055 20	INA	MERCEDES-BENZ	294
532 0624 10	INA	CITROËN	117, 120, 121, 122, 123, 125, 126, 127	533 0061 20	INA	FIAT	158, 159, 167, 168, 169, 170, 171, 172, 173, 174
532 0624 10	INA	FIAT	178	533 0061 20	INA	IVECO	222, 223, 225, 226, 227, 228, 230, 232, 236, 237, 238, 239, 240, 241, 242, 243, 244, 250, 252, 253, 254, 255, 276, 277, 278, 282, 283, 284
532 0624 10	INA	FORD	184, 187	533 0076 30	INA	VW	618, 619, 624, 647, 659
532 0624 10	INA	PEUGEOT	475, 480, 481, 485, 487, 488, 489, 490, 491, 492, 494	533 0084 30	INA	MERCEDES-BENZ	294
532 0632 10	INA	VW	615, 616	533 0085 30	INA	OPEL	411
532 0648 10	INA	MERCEDES-BENZ	306, 323, 326, 327, 349, 351	533 0085 30	INA	VAUXHALL	571
532 0650 10	INA	FIAT	179	533 0087 20	INA	NISSAN	377, 401, 402, 404, 405, 406
532 0650 10	INA	PEUGEOT	476, 478	533 0087 20	INA	OPEL	418, 422, 444, 445, 450, 455
532 0651 10	INA	FORD	202, 203	533 0087 20	INA	RENAULT	508, 515, 543, 544, 549, 550, 554, 555
532 0654 10	INA	NISSAN	407, 408	533 0087 20	INA	VAUXHALL	580, 585, 598, 603, 604, 609
532 0654 10	INA	OPEL	446, 447, 452, 453, 457, 458	533 0098 10	INA	FORD	214, 215
532 0654 10	INA	VAUXHALL	600, 601, 606, 611	533 0099 10	INA	VW	639, 640
532 0655 10	INA	FORD	186	533 0100 10	INA	MERCEDES-BENZ	310, 311, 334, 340, 356, 372
532 0667 10	INA	MERCEDES-BENZ	310, 311, 334, 340, 356	533 0108 10	INA	TOYOTA	563, 564, 565, 566, 567, 568, 569
532 0668 10	INA	NISSAN	394, 395	533 0113 10	INA	MITSUBISHI	376
532 0668 10	INA	RENAULT	503, 536, 541, 542	533 0114 10	INA	CITROËN	131, 132, 133, 134
532 0671 10	INA	MERCEDES-BENZ	298, 302, 303, 307, 313, 317, 318, 319, 324, 325, 326, 337, 342, 345, 346, 347, 350, 351, 360, 364, 365, 367, 368	533 0114 10	INA	FIAT	154, 160, 161, 162, 163, 164, 165
532 0672 10	INA	MERCEDES-BENZ	298, 302, 303, 307, 313, 317, 318, 319, 324, 325, 326, 337, 342, 345, 346, 347, 350, 351, 360, 364, 365, 367, 368	533 0114 10	INA	IVECO	224, 225, 226, 228, 229, 231, 232, 234, 235
532 0676 10	INA	CITROËN	122, 126	533 0114 10	INA	PEUGEOT	467, 468
532 0676 10	INA	PEUGEOT	489, 492	534 0011 10	INA	VW	641
532 0678 10	INA	RENAULT	496, 497, 507	534 0022 10	INA	PEUGEOT	479
532 0694 10	INA	VW	650, 652, 662	534 0031 10	INA	FORD	191, 192, 193
532 0705 10	INA	PEUGEOT	479	534 0053 10	INA	FIAT	176
532 0753 10	INA	VW	628, 629, 631	534 0053 10	INA	OPEL	410, 411
532 0773 10	INA	CITROËN	117, 121, 125, 126	534 0053 10	INA	VAUXHALL	569, 570
532 0773 10	INA	PEUGEOT	485, 489	534 0059 10	INA	VW	620, 622
532 0774 10	INA	RENAULT	500, 501, 507	534 0065 10	INA	VW	615, 616
532 0776 10	INA	FORD	203, 204, 205, 206, 207, 208, 209, 210	534 0067 10	INA	MERCEDES-BENZ	310, 311, 334, 340, 356, 372
532 0780 10	INA	NISSAN	388	534 0069 10	INA	FIAT	141, 147
532 0782 10	INA	FORD	183, 186	534 0069 10	INA	OPEL	416
532 0789 10	INA	VW	641, 642	534 0069 10	INA	VAUXHALL	575
				534 0075 20	INA	CITROËN	117, 120, 121, 122, 124, 125, 126
				534 0075 20	INA	FORD	185, 186, 187
				534 0075 20	INA	PEUGEOT	485, 486, 487, 488, 489, 491
				534 0081 30	INA	MERCEDES-BENZ	306, 323, 327, 349, 351
				534 0082 30	INA	OPEL	413, 414
				534 0082 30	INA	VAUXHALL	573
				534 0101 20	INA	FIAT	149, 150, 151





*Unique LCV Application

**Numerische Liste / Numerical listing / Liste numérique / Listado numérico / Elenco numerico /
Listy numerycznej / Перечень артикулов**

SCHAEFFLER				SCHAEFFLER			
534 0110 20	INA	CITROËN	127, 128, 130	534 0281 10	INA	OPEL	433, 434, 435, 436, 437, 438,
534 0110 20	INA	FIAT	151, 152, 154, 155, 182				439, 440, 441, 442, 443, 445,
534 0110 20	INA	PEUGEOT	463, 464, 466, 494				446, 451, 456, 457
534 0111 20	INA	CITROËN	127, 128, 130, 131	534 0281 10	INA	RENAULT	526, 527, 528, 529, 530, 531,
534 0111 20	INA	FIAT	152, 154, 155				532, 533, 534, 535, 536, 537,
534 0111 20	INA	PEUGEOT	463, 464, 466				538, 539, 540, 541, 542
534 0114 20	INA	MERCEDES-BENZ	368, 369, 370, 371, 372	534 0281 10	INA	VAUXHALL	589, 590, 591, 592, 593, 594,
							595, 596, 597, 599, 605, 609, 610
534 0115 20	INA	OPEL	412, 413	534 0308 10	INA	CITROËN	135, 136, 137, 138
534 0115 20	INA	VAUXHALL	570, 571, 572	534 0308 10	INA	FIAT	166
534 0123 20	INA	VW	616, 617	534 0308 10	INA	FORD	188, 194, 195, 197, 198, 199,
534 0128 20	INA	FORD	202, 203				200, 201, 202, 211, 212, 213
534 0130 20	INA	FORD	216	534 0308 10	INA	PEUGEOT	470, 471, 472
534 0132 30	INA	VW	643, 644, 657	534 0317 10	INA	NISSAN	377, 378, 379, 380, 381, 382,
534 0141 30	INA	RENAULT	496, 497, 499				383, 384, 385, 403, 409, 410
534 0142 30	INA	NISSAN	402, 405	534 0317 10	INA	OPEL	420, 423, 424, 425, 427, 428,
534 0142 30	INA	OPEL	418, 422, 444, 445, 447, 455,				430, 431, 448, 449, 453, 454, 459
			456, 458	534 0317 10	INA	RENAULT	509, 510, 511, 512, 515, 516,
534 0142 30	INA	RENAULT	508, 515, 543, 544, 545, 549,				517, 518, 519, 520, 521, 522,
			550, 555				523, 524, 546, 547, 548, 552,
534 0142 30	INA	VAUXHALL	580, 585, 598, 601, 603, 604,				553, 558, 559
			606, 609	534 0317 10	INA	VAUXHALL	577, 578, 581, 582, 583, 585,
534 0146 10	INA	FORD	214, 215				586, 587, 601, 602, 603, 607,
534 0151 10	INA	VW	620, 621, 622, 625, 642, 643,				608, 612, 613
			644, 656, 657, 658	534 0321 10	INA	OPEL	414
534 0164 10	INA	VW	617, 619, 623, 624, 625, 626,	534 0321 10	INA	VAUXHALL	573
			627, 630, 632, 633, 634, 636,	534 0333 10	INA	VW	650, 652, 662
			637, 638, 639, 645, 646, 648,	534 0334 10	INA	FIAT	179, 180
			649, 650, 651, 658, 659, 660,	534 0337 10	INA	MERCEDES-BENZ	298, 302, 303, 307, 313, 317,
			661, 662, 663, 666, 667, 668,				318, 319, 324, 325, 326, 337,
			670, 671, 672, 673, 674, 675, 676				342, 345, 346, 347, 350, 351,
534 0169 10	INA	FORD	188, 189				360, 364, 365, 367, 368
534 0179 10	INA	CITROËN	114	534 0341 10	INA	HYUNDAI	217, 218, 219, 220, 221, 222
534 0179 10	INA	FIAT	177	534 0360 10	INA	TOYOTA	563, 564, 565, 566, 567, 568, 569
534 0179 10	INA	PEUGEOT	482	534 0369 10	INA	FIAT	180, 181
534 0180 10	INA	CITROËN	116, 118	534 0370 10	INA	MERCEDES-BENZ	306, 323, 327, 349, 351
534 0181 10	INA	NISSAN	377, 378, 379, 380, 381, 382,				
			383, 384, 385, 403, 409, 410	534 0400 10	INA	CITROËN	116, 118, 119, 120
534 0181 10	INA	OPEL	419, 423, 425, 427, 430, 448,	534 0400 10	INA	FIAT	178, 179
			449, 453, 454, 458, 459	534 0400 10	INA	PEUGEOT	474, 475, 483, 484, 485, 486,
							487, 488
534 0181 10	INA	RENAULT	509, 510, 511, 512, 515, 516,	534 0422 10	INA	VW	669, 674, 676
			517, 518, 519, 520, 521, 522,	534 0425 10	INA	CITROËN	122, 126
			523, 524, 546, 547, 548, 552,	534 0425 10	INA	PEUGEOT	490, 492
			553, 557, 558, 559	534 0427 10	INA	CITROËN	117, 120, 121, 122
534 0181 10	INA	VAUXHALL	577, 578, 581, 582, 583, 585,	534 0427 10	INA	PEUGEOT	485, 487, 488, 489
			587, 601, 602, 603, 607, 608,	534 0434 10	INA	FORD	204, 205, 206, 207, 208, 209, 210
			612, 613	534 0444 10	INA	MERCEDES-BENZ	298, 302, 303, 307, 313, 317,
534 0183 10	INA	MERCEDES-BENZ	296, 308, 309, 328, 329, 330,				318, 319, 324, 325, 326, 337,
			331, 332, 333, 338, 339, 352,				342, 345, 346, 347, 350, 351,
			353, 354, 355, 356, 369, 370, 371				360, 364, 365, 367, 368
534 0240 10	INA	NISSAN	405	534 0447 10	INA	CITROËN	119, 123
534 0240 10	INA	OPEL	446, 447, 452, 453, 457, 458	534 0447 10	INA	PEUGEOT	486, 490
534 0240 10	INA	RENAULT	508, 515, 543, 544, 545, 546,	534 0455 10	INA	FIAT	139, 177
			549, 550, 551, 554, 555, 557	534 0455 10	INA	OPEL	415
534 0240 10	INA	VAUXHALL	600, 601, 606, 611	534 0455 10	INA	VAUXHALL	574
534 0257 10	INA	MERCEDES-BENZ	296, 308, 309, 328, 329, 330,	534 0477 10	INA	NISSAN	376
			331, 332, 333, 338, 339, 352,	534 0481 10	INA	MERCEDES-BENZ	297, 299, 300, 301, 303, 304,
			353, 354, 355, 356				305, 312, 313, 314, 315, 316,
534 0269 10	INA	NISSAN	386, 387, 388				317, 318, 320, 321, 322, 323,
534 0269 10	INA	RENAULT	496, 497, 498, 499, 500, 503,				335, 336, 337, 341, 342, 343,
			504, 505, 506, 507				344, 345, 348, 349, 357, 358,
534 0271 10	INA	RENAULT	500, 501				359, 360, 361, 362, 363, 364, 366
534 0278 10	INA	VW	639, 640	534 0506 10	INA	MERCEDES-BENZ	296, 308, 309, 328, 329, 330,
534 0280 10	INA	FIAT	174, 175				331, 332, 333, 338, 339, 352,
534 0280 10	INA	IVECO	228, 229, 232, 233, 234, 235,				353, 354, 355, 356
			236, 244, 245, 246, 247, 248,	534 0507 10	INA	FORD	183, 186
			249, 250, 251, 255, 256, 257,	534 0548 10	INA	VW	641, 642
			258, 259, 260, 261, 262, 263,	534 0590 10	INA	RENAULT	503
			264, 265, 266, 267, 268, 269,	534 0607 10	INA	FIAT	145, 146, 176
			270, 271, 272, 273, 274, 275,	534 0610 10	INA	FIAT	142, 143, 144, 165
			279, 280	534 0610 10	INA	OPEL	417
534 0281 10	INA	NISSAN	390, 391, 392, 393, 394, 395,	534 0610 10	INA	VAUXHALL	575
			396, 397, 398, 406				





*Unique LCV Application

Numerische Liste / Numerical listing / Liste numérique / Listado numérico / Elenco numerico / Listy numerycznej / Перечень артикулов

SCHAEFFLER				SCHAEFFLER			
534 0611 10	INA	MERCEDES-BENZ	373, 374, 375	535 0059 10	INA	CITROËN	116, 118, 120, 124, 128
534 0624 10	INA	FIAT	182, 183	535 0059 10	INA	FIAT	152, 154, 155, 178, 179, 180, 182
534 0624 10	INA	OPEL	460, 461, 462, 463	535 0059 10	INA	PEUGEOT	464, 474, 475, 476, 477, 478, 483, 484, 485, 486, 487, 491, 493, 494
534 0624 10	INA	RENAULT	559, 560, 561, 562, 563	535 0062 10	INA	CITROËN	116, 118, 120, 124, 128, 130, 131
534 0624 10	INA	VAUXHALL	614, 615	535 0062 10	INA	PEUGEOT	464, 466, 474, 476, 478, 483, 484, 485, 486, 487, 488, 491, 493, 494
534 0654 10	INA	CITROËN	117, 123, 127	535 0063 10	INA	FIAT	139, 140, 145, 146, 176, 177
534 0654 10	INA	PEUGEOT	480, 481, 485, 490, 492, 494, 495	535 0063 10	INA	OPEL	410, 411
534 0655 10	INA	CITROËN	117, 123, 127	535 0063 10	INA	VAUXHALL	569, 570, 571
534 0655 10	INA	PEUGEOT	480, 481, 485, 490, 492	535 0065 10	INA	OPEL	414
534 0657 10	INA	PEUGEOT	480, 481	535 0065 10	INA	VAUXHALL	574
534 0658 10	INA	PEUGEOT	480, 481	535 0079 10	INA	HYUNDAI	217, 218, 219, 220, 221, 222
534 0682 10	INA	FORD	188, 194, 195, 197, 198, 199, 200, 211, 212, 213	535 0080 10	INA	FIAT	182, 183
535 0012 10	INA	VW	617, 618, 619, 620, 621, 622, 623, 624, 625, 626, 627, 630, 632, 633, 634, 636, 637, 639, 640, 642, 643, 644, 647, 655, 656, 657, 658, 659, 665, 666	535 0080 10	INA	NISSAN	390, 391, 392, 393, 394, 395, 396, 397, 398, 399, 400, 401, 406
535 0015 10	INA	MERCEDES-BENZ	291, 292, 295, 296	535 0080 10	INA	OPEL	433, 434, 435, 436, 437, 438, 439, 440, 441, 442, 443, 445, 446, 451, 456, 457, 460, 461, 462, 463
535 0022 10	INA	FIAT	158, 159, 167, 168, 169, 170, 171, 172	535 0080 10	INA	RENAULT	503, 526, 527, 528, 529, 530, 531, 532, 533, 534, 535, 536, 537, 538, 539, 540, 541, 542, 545, 551, 556, 559, 560, 561, 562, 563
535 0022 10	INA	IVECO	222, 223, 225, 226, 227, 228, 230, 236, 237, 238, 239, 240, 241, 242, 243, 244, 250, 251, 252, 253, 254, 255, 256, 257, 276, 277, 278, 279	535 0080 10	INA	VAUXHALL	589, 590, 591, 592, 593, 594, 595, 596, 597, 599, 605, 609, 610, 614, 615
535 0023 10	INA	FIAT	149	535 0081 10	INA	NISSAN	377, 378, 379, 380, 381, 382, 383, 384, 403, 409, 410
535 0028 10	INA	RENAULT	502	535 0081 10	INA	OPEL	419, 420, 423, 424, 425, 426, 427, 428, 429, 430, 431, 448, 449, 453, 459
535 0030 10	INA	NISSAN	377, 378, 379, 380, 381, 382, 383, 384, 385, 402, 403, 404, 405, 406, 407, 408, 409, 410	535 0081 10	INA	RENAULT	503, 509, 510, 511, 512, 515, 516, 517, 518, 520, 521, 522, 523, 543, 544, 545, 546, 547, 548, 549, 550, 551, 553, 554, 555, 557, 558
535 0030 10	INA	OPEL	418, 422, 444, 445, 446, 447, 448, 449, 450, 452, 453, 454, 455, 456, 457, 458, 459	535 0081 10	INA	VAUXHALL	577, 578, 581, 582, 583, 585, 586, 587, 602, 603, 608, 612
535 0030 10	INA	RENAULT	508, 509, 510, 511, 515, 516, 517, 518, 520, 521, 522, 523, 543, 544, 545, 546, 547, 548, 549, 550, 551, 553, 554, 555, 557, 558	535 0087 10	INA	FORD	191, 192, 193
535 0030 10	INA	VAUXHALL	580, 585, 598, 600, 601, 602, 603, 604, 606, 608, 609, 611, 612, 613	535 0098 10	INA	FORD	214, 215
535 0037 10	INA	FORD	189, 190, 191	535 0102 10	INA	NISSAN	386, 387, 388
535 0039 10	INA	CITROËN	127, 128, 130, 131, 132, 133, 134	535 0102 10	INA	RENAULT	503, 504, 505, 506
535 0039 10	INA	FIAT	152, 154, 155, 182	535 0103 10	INA	CITROËN	138
535 0039 10	INA	PEUGEOT	464, 466, 467, 468, 469	535 0103 10	INA	FIAT	174, 175
535 0042 10	INA	MERCEDES-BENZ	295, 306, 323, 326, 327, 328, 329, 330, 331, 332, 333, 336, 338, 349, 351	535 0103 10	INA	IVECO	228, 229, 230, 231, 232, 233, 234, 235, 236, 244, 245, 246, 247, 248, 249, 250, 251, 254, 255, 256, 257, 258, 259, 260, 261, 262, 263, 264, 265, 266, 267, 268, 269, 270, 271, 272, 273, 274, 275, 277, 278, 279, 280, 281, 283, 284, 285, 286, 287, 288, 289
535 0048 10	INA	NISSAN	377, 402, 404, 405, 406, 407, 408	535 0103 10	INA	PEUGEOT	472, 473, 474
535 0048 10	INA	OPEL	418, 422, 444, 445, 446, 447, 450, 452, 453, 455, 456, 457, 458	535 0105 10	INA	NISSAN	386, 387, 388
535 0048 10	INA	RENAULT	508, 515, 543, 544, 545, 546, 549, 550, 551, 554, 555, 557	535 0105 10	INA	RENAULT	496, 497, 498, 499, 500, 501, 506, 507, 508
535 0048 10	INA	VAUXHALL	580, 585, 598, 600, 601, 603, 604, 606, 611	535 0109 10	INA	RENAULT	496, 497, 498, 499
535 0050 10	INA	MERCEDES-BENZ	291, 292, 295, 296, 297, 298, 299, 300, 301, 302, 303, 304, 305, 306, 307, 308, 312, 313, 314, 315, 316, 317, 318, 319, 320, 321, 322, 323, 324, 325, 326, 328, 329, 330, 335, 336, 337, 341, 342, 343, 344, 345, 346, 347, 348, 349, 350, 351, 352, 353, 357, 358, 359, 360, 361, 362, 363, 364, 365, 366, 367, 368, 369, 370, 371	535 0112 10	INA	FIAT	142, 143, 144, 165
535 0052 10	INA	VW	641, 642	535 0112 10	INA	OPEL	417
535 0053 10	INA	NISSAN	385	535 0112 10	INA	VAUXHALL	574, 575
535 0053 10	INA	OPEL	421, 425, 429, 432	535 0114 10	INA	RENAULT	496, 497, 498, 499, 500
535 0053 10	INA	RENAULT	513, 514, 519, 524, 525	535 0115 10	INA	FIAT	149, 150, 151
535 0053 10	INA	VAUXHALL	579, 584, 588	535 0116 10	INA	RENAULT	500
				535 0118 10	INA	VW	653, 654, 664, 665
				535 0124 10	INA	MAN	289, 290
				535 0124 10	INA	VW	631, 632, 633, 634, 635, 636, 637, 638, 639, 645, 646, 648, 649, 650, 651, 658, 659, 660, 661, 662, 663, 666, 667, 668,

*Unique LCV Application





**Numerische Liste / Numerical listing / Liste numérique / Listado numérico / Elenco numerico /
Listy numerycznej / Перечень артикулов**

SCHAEFFLER				SCHAEFFLER			
535 0124 10	INA	VW	669, 670, 671, 672, 673, 674, 675, 676, 677	535 0181 10	INA	FIAT	142, 143, 144, 165
535 0128 10	INA	FORD	194, 195, 196, 197, 198, 199, 200, 201, 202, 204, 205, 206, 207, 208, 209, 210, 211, 212, 213	535 0181 10	INA	OPEL	417
535 0140 10	INA	MERCEDES- BENZ	296, 308, 309, 328, 329, 330, 331, 332, 333, 336, 338, 339, 340, 352, 353, 354, 355, 356, 369, 370, 371	535 0181 10	INA	VAUXHALL	575
535 0149 10	INA	CITROËN	116, 118, 120, 124	535 0186 10	INA	VW	653, 654, 664, 665
535 0149 10	INA	FIAT	179, 180, 181	535 0193 10	INA	CITROËN	122, 126
535 0149 10	INA	PEUGEOT	475, 476, 478, 484, 485, 486, 487, 488, 491	535 0193 10	INA	PEUGEOT	490, 492
535 0151 10	INA	FIAT	139, 140, 145, 146, 176, 177	535 0194 10	INA	CITROËN	116, 117, 118, 120, 121, 124, 125, 126, 128, 131
535 0151 10	INA	OPEL	410, 411, 415	535 0194 10	INA	FIAT	152, 154, 155, 178, 179, 180, 181, 182
535 0151 10	INA	VAUXHALL	569, 570, 574	535 0194 10	INA	PEUGEOT	465, 466, 474, 475, 476, 477, 478, 479, 483, 484, 485, 486, 487, 488, 489, 491, 493, 494
535 0153 10	INA	FIAT	183	535 0210 10	INA	VW	650, 652, 662, 669, 674, 676
535 0153 10	INA	MERCEDES- BENZ	373	535 0215 10	INA	HYUNDAI	217, 218, 219, 220, 221
535 0153 10	INA	NISSAN	388, 389, 390, 391, 392, 393, 394, 395, 396, 397, 398, 399, 400, 401	535 0222 10	INA	MAN	289, 290
535 0153 10	INA	OPEL	433, 434, 435, 436, 437, 438, 439, 440, 441, 442, 443, 460, 461, 462, 463	535 0222 10	INA	VW	635, 636
535 0153 10	INA	RENAULT	526, 527, 528, 529, 530, 531, 532, 533, 534, 535, 536, 537, 538, 539, 540, 541, 542, 559, 560, 561, 562, 563	535 0223 10	INA	FORD	188, 189
535 0153 10	INA	VAUXHALL	589, 590, 591, 592, 593, 594, 595, 596, 597, 614, 615	535 0232 10	INA	TOYOTA	563, 564, 565, 566, 567, 568, 569
535 0154 10	INA	NISSAN	386, 387, 388	535 0235 10	INA	FIAT	167, 173, 174
535 0154 10	INA	RENAULT	506	535 0235 10	INA	FUSO (MITSU- BISHI)	216
535 0155 10	INA	VW	615, 616, 631	535 0235 10	INA	IVECO	282, 283, 284, 285
535 0157 10	INA	FORD	214, 215	535 0235 10	INA	MINITUBISHI	375, 376
535 0159 10	INA	FORD	191, 192, 193	535 0236 10	INA	FORD	184, 185, 186, 187
535 0160 10	INA	CITROËN	135, 136, 137, 138	535 0237 10	INA	FORD	184, 185, 186, 187
535 0160 10	INA	FIAT	166	535 0245 10	INA	HYUNDAI	217, 218, 219, 220, 221
535 0160 10	INA	FORD	188, 194, 195, 196, 197, 211, 212, 213	535 0268 10	INA	FORD	186
535 0160 10	INA	PEUGEOT	470, 471, 472	535 0279 10	INA	VW	628, 629
535 0165 10	INA	MERCEDES- BENZ	306, 323, 326, 327, 349, 351	535 0284 10	INA	FORD	183
535 0166 10	INA	CITROËN	122, 126	535 0308 10	INA	CITROËN	117, 123, 127
535 0166 10	INA	PEUGEOT	490, 492	535 0308 10	INA	PEUGEOT	480, 481, 485, 490, 492, 494, 495
535 0168 10	INA	MERCEDES- BENZ	295, 297, 298, 299, 300, 301, 302, 303, 304, 305, 306, 312, 313, 314, 315, 316, 317, 318, 319, 320, 321, 322, 323, 326, 328, 329, 330, 331, 332, 333, 336, 338, 341, 342, 343, 344, 345, 346, 347, 348, 351, 357, 358, 359, 360, 361, 362, 363, 364, 365, 366, 367, 368, 373, 374, 375	535 0310 10	INA	FORD	187, 188, 210, 211
535 0171 10	INA	FIAT	139, 141	535 0311 10	INA	FIAT	139, 140
535 0171 10	INA	OPEL	416	535 0311 10	INA	OPEL	415
535 0172 10	INA	VAUXHALL	570	535 0311 10	INA	VAUXHALL	574
535 0173 10	INA	TOYOTA	563, 564, 565, 566, 567, 568	535 0314 10	INA	FORD	191, 192, 193
535 0176 10	INA	CITROËN	138	535 0317 10	INA	CITROËN	134, 135, 136, 137, 138
535 0176 10	INA	FIAT	174, 175	535 0317 10	INA	PEUGEOT	469, 470, 471, 475, 479, 480, 481, 494
535 0176 10	INA	IVECO	244, 245, 246, 247, 248, 251, 257, 258, 259, 263, 264, 265, 266, 267, 271, 272, 273, 275, 279, 280, 281, 284, 285, 286, 287, 289	535 0327 10	INA	OPEL	415
535 0176 10	INA	PEUGEOT	472, 473, 474	535 0344 10	INA	NISSAN	388, 389
535 0177 10	INA	NISSAN	376, 377	538 0008 10	INA	CITROËN	127, 128
535 0178 10	INA	CITROËN	122, 126	538 0008 10	INA	FIAT	152, 155, 182
535 0178 10	INA	PEUGEOT	490, 492	538 0008 10	INA	PEUGEOT	463, 465, 493, 494
535 0179 10	INA	CITROËN	116, 118, 120, 124, 127, 128, 131	538 0009 10	INA	PEUGEOT	482
535 0179 10	INA	PEUGEOT	463, 464, 466, 474, 475, 476, 477, 478, 483, 484, 485, 486, 487, 488, 491, 493, 494	538 0012 10	INA	VAUXHALL	571, 572
				538 0013 10	INA	FIAT	149, 150, 151
				538 0018 10	INA	FIAT	144
				538 0021 10	INA	RENAULT	507
				538 0024 10	INA	VAUXHALL	571
				538 0026 10	INA	VW	616, 617
				538 0037 10	INA	CITROËN	116, 117, 118, 119, 120, 121, 123, 124, 125, 126, 127
				538 0037 10	INA	FIAT	178, 179
				538 0037 10	INA	FORD	184, 185, 186, 187
				538 0037 10	INA	PEUGEOT	475, 483, 484, 485, 487, 488, 489, 490, 491, 492
				538 0038 10	INA	VW	624, 647, 659
				538 0045 10	INA	VW	639, 640, 641
				538 0046 10	INA	RENAULT	496
				538 0047 10	INA	NISSAN	386, 387, 388
				538 0047 10	INA	RENAULT	496, 497, 498, 499, 500, 503, 504, 505, 506
				538 0052 10	INA	CITROËN	119, 123
				538 0052 10	INA	PEUGEOT	486, 491
				538 0054 10	INA	VW	620, 622, 642, 643, 644, 656, 657, 658
				538 0055 10	INA	CITROËN	114, 115
				538 0055 10	INA	FIAT	177
				538 0055 10	INA	PEUGEOT	482
				538 0057 10	INA	RENAULT	502

*Unique LCV Application







Numerische Liste / Numerical listing / Liste numérique / Listado numérico / Elenco numerico / Listy numerycznej / Перечень артикулов

SCHAEFFLER				SCHAEFFLER			
538 0060 10	INA	VW	617, 619, 623, 624, 625, 626, 627, 630, 633, 634, 636, 637, 638, 639, 645, 646, 648, 649, 650, 651, 652, 658, 659, 660, 661, 662, 663, 666, 667, 668, 670, 671, 672, 673, 674, 675, 676	538 0374 10	INA	NISSAN	378, 379, 380, 381, 382, 383, 384, 385, 403, 408, 409, 410
538 0062 10	INA	FIAT	140, 141, 147, 177, 178	538 0374 10	INA	OPEL	419, 420, 421, 423, 424, 425, 426, 427, 428, 429, 430, 431, 448, 449, 453, 454, 459
538 0062 10	INA	OPEL	416	538 0374 10	INA	RENAULT	509, 510, 511, 512, 515, 516, 517, 518, 519, 520, 521, 522, 523, 524, 546, 547, 548, 552, 553, 558, 559
538 0062 10	INA	VAUXHALL	575	538 0374 10	INA	VAUXHALL	577, 578, 579, 581, 582, 583, 586, 587, 602, 603, 608, 613
538 0075 10	INA	VW	615, 616	538 0375 10	INA	RENAULT	500, 501, 507, 508
538 0077 10	INA	CITROËN	134, 135	538 0383 10	INA	NISSAN	388
538 0077 10	INA	PEUGEOT	469	538 0384 10	INA	NISSAN	385
538 0082 10	INA	OPEL	411	538 0384 10	INA	OPEL	421, 425, 429, 432
538 0082 10	INA	VAUXHALL	571	538 0384 10	INA	RENAULT	513, 519, 525
538 0088 10	INA	VW	618, 619	538 0384 10	INA	VAUXHALL	579, 584, 588
538 0089 10	INA	VW	626	538 0392 10	INA	NISSAN	377, 402, 404, 405, 406, 407, 408
538 0095 10	INA	RENAULT	504, 505, 506	538 0392 10	INA	OPEL	418, 422, 444, 445, 446, 447, 450, 451, 452, 453, 455, 456, 457, 458
538 0096 10	INA	OPEL	413, 414	538 0392 10	INA	RENAULT	508, 515, 543, 544, 545, 546, 549, 550, 551, 552, 554, 555, 557
538 0096 10	INA	VAUXHALL	573, 574	538 0392 10	INA	VAUXHALL	580, 585, 598, 599, 600, 601, 604, 606, 609, 611
538 0102 10	INA	FIAT	180, 181	538 0397 10	INA	NISSAN	390, 391, 392, 393, 395, 396, 397, 398, 400, 406
538 0102 10	INA	PEUGEOT	475, 477, 479	538 0397 10	INA	OPEL	433, 434, 435, 437, 438, 440, 441, 442, 443, 445, 446, 451, 452, 456, 457
538 0130 10	INA	FIAT	158, 159, 167, 168, 169, 170, 171, 172, 173	538 0397 10	INA	RENAULT	526, 527, 528, 530, 531, 532, 535, 536, 537, 538, 539, 545, 551, 556
538 0130 10	INA	IVECO	222, 223, 225, 226, 227, 228, 230, 231, 232, 236, 237, 238, 239, 240, 241, 242, 243, 244, 245, 248, 250, 251, 252, 253, 254, 255, 276, 277, 278, 282, 283, 284, 369, 370	538 0397 10	INA	VAUXHALL	589, 590, 591, 592, 594, 595, 596, 599, 600, 605, 610
538 0211 10	INA	MERCEDES-BENZ	369, 370, 371, 372	538 0399 10	INA	FIAT	183
538 0212 10	INA	MERCEDES-BENZ	291, 292, 295, 296, 297	538 0399 10	INA	MERCEDES-BENZ	373
538 0220 10	INA	MERCEDES-BENZ	298, 302, 307, 313, 318, 319, 324, 325, 337, 342, 350	538 0399 10	INA	NISSAN	388, 389
538 0221 10	INA	MERCEDES-BENZ	297, 298, 299, 300, 301, 303, 304, 305, 306, 312, 313, 314, 315, 316, 317, 318, 320, 321, 322, 323, 335, 336, 337, 341, 342, 343, 344, 345, 348, 349, 357, 358, 359, 360, 361, 362, 363, 364, 366, 367	538 0399 10	INA	OPEL	460, 461, 462, 463
538 0224 10	INA	MERCEDES-BENZ	308, 309, 310, 328, 329, 330, 331, 332, 333, 338, 339, 340, 352, 353, 354, 355, 356, 369, 371	538 0399 10	INA	RENAULT	559, 560, 561, 562, 563
538 0234 10	INA	MERCEDES-BENZ	295	538 0399 10	INA	VAUXHALL	614, 615
538 0238 10	INA	MERCEDES-BENZ	310, 311, 334, 340, 356, 369, 373	538 0428 10	INA	CITROËN	130, 131
538 0244 10	INA	MERCEDES-BENZ	294	538 0428 10	INA	FIAT	179, 180, 181
538 0248 10	INA	MERCEDES-BENZ	216	538 0428 10	INA	PEUGEOT	466, 476, 478
538 0255 10	INA	FORD	214, 215	538 0442 10	INA	FIAT	139, 140, 145, 146, 176, 177
538 0256 10	INA	FORD	188, 189	538 0442 10	INA	OPEL	410, 411, 415
538 0259 10	INA	FORD	188, 189	538 0442 10	INA	VAUXHALL	569, 570, 574
538 0260 10	INA	FORD	191, 192, 193, 204, 205, 206, 207, 208, 209	538 0445 10	INA	IVECO	224, 231, 234, 235
538 0262 10	INA	FORD	186	538 0448 10	INA	FIAT	148
538 0264 10	INA	FORD	183, 186	538 0449 10	INA	FIAT	148
538 0266 10	INA	FORD	209, 210	538 0465 10	INA	CITROËN	136, 137, 138
538 0267 10	INA	FORD	189, 190, 191	538 0465 10	INA	FIAT	166
538 0270 10	INA	FORD	412, 413	538 0465 10	INA	FORD	188, 194, 195, 196, 197, 198, 199, 200, 201, 202, 211, 212, 213
538 0296 10	INA	OPEL	412	538 0465 10	INA	PEUGEOT	470, 471, 472
538 0296 10	INA	VAUXHALL	571, 572	538 0466 10	INA	CITROËN	122, 126
538 0302 10	INA	OPEL	412	538 0466 10	INA	PEUGEOT	490, 492
538 0302 10	INA	VAUXHALL	571, 572	538 0468 10	INA	CITROËN	129
538 0320 10	INA	OPEL	412	538 0468 10	INA	FIAT	156, 157, 158
538 0320 10	INA	VAUXHALL	571	538 0468 10	INA	PEUGEOT	465
538 0334 10	INA	VW	655, 656, 665, 666	538 0469 10	INA	CITROËN	131, 132, 133, 134
538 0338 10	INA	VW	653, 654, 664, 665	538 0469 10	INA	FIAT	153, 154, 161, 162, 163, 164, 165
538 0363 10	INA	VW	628, 629	538 0469 10	INA	IVECO	225, 226, 229, 232, 233, 234, 235
538 0373 10	INA	RENAULT	496, 498, 499	538 0469 10	INA	PEUGEOT	467, 468, 469
				538 0472 10	INA	CITROËN	138
				538 0472 10	INA	FIAT	175
				538 0472 10	INA	IVECO	228, 229, 232, 233, 234, 235, 236, 279, 280
				538 0472 10	INA	PEUGEOT	472, 473, 474
				538 0500 10	INA	PEUGEOT	478, 479
				538 0534 10	INA	TOYOTA	563, 564, 565, 566, 567, 568, 569





*Unique LCV Application

**Numerische Liste / Numerical listing / Liste numérique / Listado numérico / Elenco numerico /
Listy numerycznej / Перечень артикулов**

SCHAEFFLER				SCHAEFFLER			
538 0575 10	INA	IVECO	247, 249, 250, 257, 259, 260, 261, 264, 265, 266, 268, 270, 271, 272, 273, 275	544 0094 10	INA	OPEL	421, 424, 428, 431, 448, 454, 459
538 0588 10	INA	DAEWOO	376	544 0094 10	INA	RENAULT	511, 517, 522, 548, 553, 558
538 0591 10	INA	HYUNDAI	221	544 0094 10	INA	VAUXHALL	578, 582, 586, 602, 608, 612
538 0660 10	INA	HYUNDAI	217, 218, 219, 220, 221, 222	544 0095 10	INA	FIAT	179, 180, 181
538 0714 10	INA	FIAT	142, 143, 144, 165	544 0095 10	INA	PEUGEOT	475, 476, 477, 478
538 0714 10	INA	OPEL	417	544 0096 10	INA	CITROËN	122, 126
538 0714 10	INA	VAUXHALL	575, 576	544 0096 10	INA	PEUGEOT	490, 492
538 0733 10	INA	VW	631, 632, 633, 634, 635, 667, 672, 674, 675, 677	544 0097 10	INA	CITROËN	134, 135
538 0749 10	INA	MERCEDES-BENZ	358, 359, 360, 364, 365, 367, 368	544 0097 10	INA	FIAT	179, 180, 181
538 0800 10	INA	MERCEDES-BENZ	358, 359, 360, 364, 365, 367, 368	544 0097 10	INA	PEUGEOT	469, 476, 477, 478, 479
538 0804 10	INA	MERCEDES-BENZ	373, 374, 375	544 0097 20	INA	CITROËN	134, 135
538 0807 10	INA	MAN	289, 290	544 0097 20	INA	FIAT	179, 180, 181
538 0807 10	INA	VW	636, 666, 667, 669, 671, 672, 673, 674, 675, 677	544 0097 20	INA	PEUGEOT	469, 476, 477, 478, 479
544 0002 10	INA	VW	639, 640, 641	544 0098 10	INA	OPEL	419, 420, 421, 423, 424, 425, 426, 427, 428, 429, 430, 431, 448, 449, 453, 459
544 0002 20	INA	VW	639, 640, 641	544 0098 10	INA	RENAULT	509, 510, 511, 512, 515, 516, 517, 518, 519, 520, 521, 522, 523, 524, 548, 553
544 0003 10	INA	VW	624, 647, 659	544 0098 10	INA	VAUXHALL	576, 577, 578, 581, 582, 583, 585, 587, 601, 603, 607, 608, 612, 613
544 0009 10	INA	RENAULT	502	544 0101 10	INA	NISSAN	404, 405, 406
544 0009 20	INA	RENAULT	502	544 0101 10	INA	OPEL	418, 422, 444, 445, 450, 455, 456
544 0017 10	INA	FIAT	158, 159, 167, 168, 169, 170, 171, 172, 173	544 0101 10	INA	RENAULT	543, 544, 549, 555
544 0029 10	INA	FIAT	139, 176, 177	544 0101 10	INA	VAUXHALL	580, 585, 598, 603, 604, 609
544 0029 10	INA	OPEL	410, 411, 415	544 0101 20	INA	NISSAN	404, 405, 406
544 0029 10	INA	VAUXHALL	569, 570, 574	544 0101 20	INA	OPEL	418, 422, 444, 445, 450, 451, 455, 456
544 0030 10	INA	FIAT	140	544 0101 20	INA	RENAULT	543, 544, 549, 555
544 0032 10	INA	FIAT	144	544 0101 20	INA	VAUXHALL	580, 585, 598, 599, 603, 604, 609
544 0035 10	INA	FIAT	145, 146, 176	544 0104 10	INA	CITROËN	116, 117, 118, 119, 120, 121, 122, 124, 125, 126
544 0039 10	INA	CITROËN	127, 128, 130, 131	544 0104 10	INA	FIAT	178, 179
544 0039 10	INA	FIAT	152, 154, 155, 182	544 0104 10	INA	FORD	184, 185, 186, 187
544 0039 10	INA	PEUGEOT	463, 465, 466, 493, 494	544 0104 10	INA	PEUGEOT	474, 475, 483, 484, 485, 486, 487, 488, 489, 491, 494, 495
544 0039 20	INA	CITROËN	127, 128, 130, 131	544 0104 20	INA	CITROËN	116, 117, 118, 119, 120, 121, 122, 124, 125, 126
544 0039 20	INA	FIAT	152, 154, 155, 182	544 0104 20	INA	FIAT	178
544 0039 20	INA	PEUGEOT	463, 465, 466, 493, 494	544 0104 20	INA	FORD	184, 185, 186, 187
544 0054 10	INA	NISSAN	386, 387, 388	544 0104 20	INA	PEUGEOT	475, 483, 484, 485, 486, 487, 488, 489, 491, 494, 495
544 0054 10	INA	RENAULT	497, 499	544 0110 10	INA	NISSAN	378, 379, 380, 383, 384, 409, 410
544 0054 20	INA	NISSAN	386, 387, 388	544 0110 10	INA	RENAULT	510, 511, 515, 516, 517, 518, 519, 521, 522, 523, 524, 546, 548, 552, 553, 559
544 0054 20	INA	RENAULT	498, 499	544 0111 10	INA	MERCEDES-BENZ	295, 296, 297
544 0058 10	INA	FIAT	182	544 0116 10	INA	MERCEDES-BENZ	291, 292, 297, 298, 299, 300, 301, 303, 304, 305, 306, 312, 313, 314, 315, 316, 317, 318, 320, 321, 322, 323, 335, 336, 337, 341, 342, 343, 344, 345, 348, 349, 357, 358, 359, 360, 361, 362, 364, 366, 367
544 0058 10	INA	PEUGEOT	493, 494	544 0145 10	INA	CITROËN	114, 115, 119, 123, 124
544 0058 20	INA	FIAT	182	544 0145 10	INA	FIAT	177, 178
544 0058 20	INA	PEUGEOT	493, 494	544 0145 10	INA	PEUGEOT	482, 486, 490
544 0065 10	INA	VW	643, 644, 657	553 0124 10	INA	RENAULT	498, 499, 501, 502, 508, 515, 543, 550, 555
544 0079 10	INA	CITROËN	118	553 0128 10	INA	CITROËN	114, 115, 130, 131
544 0079 20	INA	CITROËN	118	553 0128 10	INA	PEUGEOT	494
544 0080 20	INA	FIAT	142, 143, 144, 149, 150, 151	553 0147 10	INA	MERCEDES-BENZ	291, 297, 298, 299, 300, 301, 303, 304, 305, 306, 310, 311, 312, 313, 314, 315, 316, 318, 320, 321, 322, 323, 334, 341, 342, 343, 344, 348, 357, 358, 359, 360, 361, 362, 363, 364, 366, 367
544 0080 20	INA	OPEL	417	553 0151 10	INA	FORD	190, 191
544 0080 20	INA	VAUXHALL	575, 576	553 0237 10	INA	CITROËN	122, 126
544 0081 10	INA	OPEL	414	553 0237 10	INA	PEUGEOT	490, 492
544 0081 10	INA	VAUXHALL	574	553 0272 10	INA	CITROËN	119, 124, 125
544 0083 10	INA	VW	620, 621, 622, 626, 642, 643, 644, 656, 657, 658				
544 0083 20	INA	VW	620, 621, 622, 626, 642, 643, 644, 656, 657, 658				
544 0087 10	INA	PEUGEOT	493				
544 0087 20	INA	PEUGEOT	493				
544 0089 10	INA	NISSAN	404				
544 0089 10	INA	OPEL	418, 422, 444, 445, 450, 455, 456				
544 0089 10	INA	RENAULT	543, 544, 545, 549, 550, 554, 555				
544 0089 10	INA	VAUXHALL	580, 585, 598, 603, 604, 609				
544 0090 10	INA	NISSAN	386, 387, 388				
544 0090 10	INA	RENAULT	496, 497, 498, 499, 500, 503, 504, 505, 506, 507, 508				
544 0090 20	INA	NISSAN	386, 387, 388				
544 0090 20	INA	RENAULT	496, 497, 498, 499, 500, 503, 504, 505, 506, 507, 508				
544 0091 10	INA	RENAULT	500, 501				
544 0091 20	INA	RENAULT	500, 501				
544 0094 10	INA	NISSAN	378				





*Unique LCV Application

Numerische Liste / Numerical listing / Liste numérique / Listado numérico / Elenco numerico / Listy numerycznej / Перечень артикулов

SCHAEFFLER				SCHAEFFLER			
553 0272 10	INA	PEUGEOT	486, 491	559 0051 10	INA	MERCEDES-BENZ	306, 323, 326, 327, 349, 351
553 0296 10	INA	MERCEDES-BENZ	291, 292, 294, 295, 296, 297, 369, 370, 372	559 0053 10	INA	FIAT	140, 145, 146, 176, 177
553 0310 10	INA	PEUGEOT	465	559 0053 10	INA	OPEL	410, 411, 415
553 0310 10	INA	VW	656	559 0053 10	INA	VAUXHALL	569, 570, 574
553 0388 10	INA	VW	650, 652, 662, 669, 674, 676	559 0057 10	INA	OPEL	412
558 0039 10	INA	MERCEDES-BENZ	296, 308, 309, 310, 328, 329, 330, 331, 332, 333, 338, 339, 340, 352, 353, 354, 355, 356, 369, 371	559 0057 10	INA	VAUXHALL	571
558 0040 10	INA	MERCEDES-BENZ	296, 308, 309, 310, 328, 329, 330, 331, 332, 333, 338, 339, 340, 352, 353, 354, 355, 356, 369, 371	559 0067 10	INA	VW	647, 659
558 0041 10	INA	MERCEDES-BENZ	310, 311, 334, 340, 341, 356, 357, 373	559 0068 10	INA	VW	620, 621, 622, 626
558 0055 10	INA	FORD	192, 193	559 0069 10	INA	VW	642, 643, 644, 656, 657, 658
558 0056 10	INA	VW	615	559 0073 10	INA	VW	655, 656, 665, 666
558 0059 10	INA	NISSAN	406, 407	559 0079 10	INA	VW	615, 616
558 0059 10	INA	OPEL	445, 446, 451, 452, 456, 457	559 0087 10	INA	MERCEDES-BENZ	296, 308, 309, 310, 328, 329, 330, 331, 332, 333, 338, 339, 340, 352, 353, 354, 355, 356, 369, 371
558 0059 10	INA	RENAULT	545, 551, 556	559 0088 10	INA	MERCEDES-BENZ	296, 308, 309, 310, 328, 329, 330, 331, 332, 333, 338, 339, 340, 352, 353, 354, 355, 356, 369, 371
558 0059 10	INA	VAUXHALL	599, 600, 605, 610	559 0093 10	INA	MERCEDES-BENZ	310, 311, 334, 340, 341, 356, 357, 373
558 0060 10	INA	NISSAN	390, 392, 393, 394, 397, 398	559 0104 10	INA	CITROËN	122, 126
558 0060 10	INA	OPEL	433, 437, 438, 440, 441	559 0104 10	INA	PEUGEOT	490, 492
558 0060 10	INA	RENAULT	526, 527, 528, 530, 531, 532, 535, 536, 537, 538, 539, 540	559 0106 10	INA	CITROËN	116, 118, 120, 124, 134, 135
558 0060 10	INA	VAUXHALL	589, 590, 591, 592, 596	559 0106 10	INA	PEUGEOT	469, 475, 484, 485, 487, 488, 489
558 0062 10	INA	FORD	188, 194, 195, 196, 197, 198, 199, 200, 201, 202, 204, 205, 206, 207, 208, 209, 210, 211, 212, 213, 214	559 0111 10	INA	FIAT	179, 180, 181, 182
558 0063 10	INA	CITROËN	136, 137	559 0111 10	INA	PEUGEOT	476, 477, 478, 479
558 0063 10	INA	FIAT	166	559 0123 10	INA	HYUNDAI	217, 218, 219, 221, 222
558 0063 10	INA	FORD	194, 196, 197, 199, 200, 201, 202, 204, 206, 207, 208	559 0126 10	INA	HYUNDAI	217, 218, 219, 221, 222
558 0063 10	INA	PEUGEOT	470, 471	559 0127 10	INA	HYUNDAI	217, 218, 219, 221, 222
558 0064 10	INA	FORD	188, 189	559 0128 10	INA	HYUNDAI	217, 218, 219, 221, 222
558 0065 10	INA	FORD	191	559 0135 10	INA	FIAT	140, 145, 146, 176, 177
558 0066 10	INA	CITROËN	136, 137	559 0135 10	INA	OPEL	410, 411, 415
558 0066 10	INA	FIAT	166	559 0135 10	INA	VAUXHALL	569, 570, 574
558 0066 10	INA	FORD	194, 196, 197, 199, 200, 201, 202, 204, 206, 207, 208	559 0146 10	INA	FIAT	140, 145, 146, 176, 177
558 0066 10	INA	PEUGEOT	470, 471	559 0146 10	INA	OPEL	410, 411, 415
559 0019 10	INA	FIAT	140, 145, 146, 176, 177	559 0146 10	INA	VAUXHALL	569, 570, 574
559 0019 10	INA	OPEL	410, 411, 415	559 0152 10	INA	FORD	192, 193
559 0019 10	INA	VAUXHALL	569, 570, 574	559 0152 30	INA	FORD	192, 193
559 0024 30	INA	OPEL	412	559 0171 10	INA	NISSAN	406, 407
559 0024 30	INA	VAUXHALL	571	559 0171 10	INA	OPEL	445, 446, 451, 452, 456, 457
559 0025 30	INA	OPEL	412	559 0171 10	INA	RENAULT	545, 551, 556
559 0025 30	INA	VAUXHALL	571	559 0171 30	INA	VAUXHALL	599, 600, 605, 610
559 0026 30	INA	VW	615, 616	559 0171 30	INA	OPEL	445, 446, 451, 452, 456, 457
559 0027 30	INA	FIAT	140, 145, 146, 176, 177	559 0171 30	INA	RENAULT	545, 551, 556
559 0027 30	INA	OPEL	410, 411, 415	559 0171 30	INA	VAUXHALL	599, 600, 605, 610
559 0027 30	INA	VAUXHALL	569, 570, 574	559 0172 10	INA	NISSAN	390, 392, 393, 394, 397, 398
559 0028 30	INA	FIAT	140, 145, 146, 176, 177	559 0172 10	INA	OPEL	433, 437, 438, 440, 441
559 0028 30	INA	OPEL	410, 411, 415	559 0172 10	INA	RENAULT	526, 527, 528, 530, 531, 532, 535, 536, 537, 538, 539, 540
559 0028 30	INA	VAUXHALL	569, 570, 574	559 0172 30	INA	VAUXHALL	589, 590, 591, 592, 596
559 0039 10	INA	MERCEDES-BENZ	291, 292, 295, 296, 297, 298, 299, 300, 301, 302, 303, 304, 305, 306, 312, 313, 314, 315, 316, 318, 320, 321, 322, 323, 341, 342, 343, 344, 348, 357, 358, 359, 360, 361, 362, 363, 364, 366, 367	559 0172 30	INA	NISSAN	390, 392, 393, 394, 397, 398
559 0042 10	INA	MERCEDES-BENZ	369, 370, 372	559 0172 30	INA	OPEL	433, 437, 438, 440, 441
559 0045 10	INA	MERCEDES-BENZ	306, 323, 326, 327, 349, 351	559 0172 30	INA	RENAULT	526, 527, 528, 530, 531, 532, 535, 536, 537, 538, 539, 540
559 0046 10	INA	MERCEDES-BENZ	294	559 0172 30	INA	VAUXHALL	589, 590, 591, 592, 596
559 0049 10	INA	MERCEDES-BENZ	308, 309, 328, 329, 330, 352, 353, 354, 355, 369, 371	559 0176 10	INA	FORD	192, 193
559 0050 10	INA	MERCEDES-BENZ	308, 309, 328, 329, 330, 352, 353, 354, 355, 369, 371	559 0176 30	INA	FORD	192, 193
				559 0184 10	INA	FORD	204, 205, 206, 207, 208, 209, 212, 213, 214
				559 0187 10	INA	FORD	188, 189
				559 0187 30	INA	FORD	188, 189
				559 0188 10	INA	FORD	188, 189
				559 0188 30	INA	FORD	188, 189
				559 0189 10	INA	FORD	189, 191
				559 0189 30	INA	FORD	189, 191
				559 0193 10	INA	CITROËN	136, 137
				559 0193 10	INA	FIAT	166
				559 0193 10	INA	FORD	194, 196, 197, 199, 200, 201, 202, 204, 206, 207, 208
				559 0193 10	INA	PEUGEOT	470, 471
				559 0193 30	INA	CITROËN	136, 137

*Unique LCV Application





**Numerische Liste / Numerical listing / Liste numérique / Listado numérico / Elenco numerico /
Listy numerycznej / Перечень артикулов**

SCHAEFFLER				SCHAEFFLER			
559 0193 30	INA	FIAT	166, 167	600 0299 00	LUK	VW	622, 623, 625, 626, 627, 632, 633, 634
559 0193 30	INA	FORD	194, 196, 197, 199, 200, 201, 202, 204, 206, 207, 208	600 0315 00	LUK	FORD	188, 194, 197, 202, 211, 212, 213
559 0193 30	INA	PEUGEOT	470, 471	600 0318 00	LUK	CITROËN	136
559 0196 10	INA	VW	650, 652, 662, 669, 674, 676	600 0318 00	LUK	PEUGEOT	471
600 0016 00	LUK	VW	620	600 0321 00	LUK	VW	647, 648, 649, 650, 659, 660, 661
600 0017 00	LUK	VW	621, 622, 623, 625, 626, 627	602 0002 00	LUK	VW	618
600 0023 00	LUK	FORD	192	602 0005 00	LUK	RENAULT	503
600 0024 00	LUK	FORD	191, 192, 193	602 0006 00	LUK	VW	629
600 0044 00	LUK	FORD	214	602 0007 00	LUK	VW	618, 630
600 0048 00	LUK	FIAT	181, 182	602 0018 00	LUK	VW	647, 649, 651, 660, 661, 662, 663, 668, 670, 673, 674, 675, 676, 677
600 0056 00	LUK	MERCEDES-BENZ	290, 291	618 3032 00	LUK	FIAT	144
600 0060 00	LUK	MERCEDES-BENZ	294	618 3091 00	LUK	RENAULT	495
600 0065 00	LUK	MERCEDES-BENZ	293	620 1080 00	LUK	RENAULT	500, 501
600 0078 00	LUK	NISSAN	403, 408	620 3080 00	LUK	FIAT	149
600 0078 00	LUK	RENAULT	547, 552, 558	620 3081 00	LUK	PEUGEOT	493
600 0084 00	LUK	CITROËN	119, 124	620 3084 00	LUK	CITROËN	114, 115
600 0084 00	LUK	PEUGEOT	486, 491	620 3084 00	LUK	PEUGEOT	481, 482, 490
600 0125 00	LUK	VW	653, 663, 664	620 3086 00	LUK	FIAT	177
600 0136 00	LUK	FIAT	179, 180	620 3086 21	LUK	FIAT	177
600 0136 00	LUK	PEUGEOT	476, 477	620 3086 22	LUK	FIAT	177
600 0164 00	LUK	OPEL	410, 411	620 3087 00	LUK	CITROËN	118, 123
600 0164 00	LUK	VAUXHALL	569, 570	620 3087 00	LUK	PEUGEOT	486, 490
600 0165 00	LUK	OPEL	410, 411	620 3090 34	LUK	OPEL	411
600 0165 00	LUK	VAUXHALL	569, 570	620 3090 34	LUK	VAUXHALL	571
600 0166 00	LUK	OPEL	414	620 3096 00	LUK	PEUGEOT	493
600 0166 00	LUK	VAUXHALL	573	620 3105 00	LUK	FIAT	178
600 0169 00	LUK	VW	642, 643, 644, 656, 657	620 3119 09	LUK	RENAULT	507
600 0173 00	LUK	FORD	193, 203, 204, 205, 206, 207, 208	620 3119 33	LUK	RENAULT	506, 507
600 0186 00	LUK	FORD	203, 204	620 3128 00	LUK	FIAT	147, 148
600 0197 00	LUK	NISSAN	387	620 3445 00	LUK	FIAT	140, 147, 177
600 0197 00	LUK	RENAULT	505, 506	621 3026 33	LUK	OPEL	411
600 0199 00	LUK	VW	624	621 3027 33	LUK	OPEL	412, 413
600 0202 00	LUK	VW	640	621 3027 33	LUK	VAUXHALL	571, 572
600 0206 00	LUK	HYUNDAI	217, 219, 220, 221	621 3029 33	LUK	OPEL	414
600 0215 00	LUK	VW	653, 654, 664, 665	621 3029 33	LUK	VAUXHALL	573
600 0216 00	LUK	FIAT	149, 150, 151	621 3029 34	LUK	OPEL	413
600 0219 00	LUK	HYUNDAI	217, 218, 219, 220	621 3029 34	LUK	VAUXHALL	573
600 0231 00	LUK	VW	639, 640	621 3045 33	LUK	OPEL	412, 413
600 0235 00	LUK	NISSAN	390, 391, 392, 393, 397	622 3036 00	LUK	RENAULT	502
600 0235 00	LUK	OPEL	432, 433, 437, 440	622 3055 00	LUK	RENAULT	496, 497, 499
600 0235 00	LUK	RENAULT	526, 528, 529, 530, 532, 535, 536, 537, 538, 539	622 3095 33	LUK	OPEL	410, 411
600 0235 00	LUK	VAUXHALL	588, 591, 595	622 3095 33	LUK	VAUXHALL	569, 570
600 0255 00	LUK	MERCEDES-BENZ	297, 298, 299, 300, 301, 303, 304, 305, 311, 312, 313, 314, 315, 316, 317, 321, 322, 334, 336, 341, 343, 344, 345, 347, 348, 349	622 3096 09	LUK	RENAULT	503
600 0260 00	LUK	MERCEDES-BENZ	301, 303, 304, 305, 317, 321, 322, 336, 345, 347, 348, 349	622 3096 33	LUK	NISSAN	386
600 0262 00	LUK	FORD	195, 198, 200, 201, 211, 212, 213, 214	622 3096 33	LUK	RENAULT	497, 498, 499, 503
600 0274 00	LUK	IVECO	227, 228, 231, 232, 234, 235, 244, 245, 246, 247, 248, 251, 255, 256, 257, 260, 261, 262, 263, 264, 266, 267, 268, 270, 271, 274, 275, 281, 284, 285, 287, 288, 289	622 3096 35	LUK	RENAULT	503, 504, 505
600 0275 00	LUK	VW	639, 640	622 3100 33	LUK	OPEL	410, 411
600 0277 00	LUK	FORD	184	622 3100 33	LUK	VAUXHALL	569, 570
600 0290 00	LUK	MERCEDES-BENZ	357, 358, 359, 360, 361, 362, 363, 366	622 3103 09	LUK	RENAULT	507
600 0291 00	LUK	MERCEDES-BENZ	295, 298, 299, 300, 301, 302, 303, 304, 307, 313, 314, 315, 316, 318, 319, 320, 324, 325, 335, 337, 342, 343, 345, 346, 347, 349, 350, 351, 360, 364, 365, 367, 368	622 3103 33	LUK	RENAULT	507
600 0295 00	LUK	VW	622, 623, 625, 626, 627	622 3132 09	LUK	FIAT	141
				622 3132 09	LUK	OPEL	416
				622 3135 34	LUK	FIAT	176
				622 3146 33	LUK	OPEL	410, 411
				622 3146 33	LUK	VAUXHALL	569, 570
				622 3174 09	LUK	FORD	215
				622 3174 33	LUK	FORD	215
				622 3199 33	LUK	NISSAN	388
				622 3231 33	LUK	FORD	186, 187
				622 3236 33	LUK	OPEL	411
				622 3236 33	LUK	VAUXHALL	570
				622 3238 00	LUK	FIAT	139, 145, 146, 176, 177
				622 3238 00	LUK	OPEL	415
				622 3238 00	LUK	VAUXHALL	574
				622 3336 00	LUK	VW	615, 616, 617, 618, 622, 623, 628
				622 3427 33	LUK	RENAULT	504, 505
				622 3429 33	LUK	RENAULT	504, 505
				622 3429 34	LUK	NISSAN	386
				622 3456 09	LUK	FORD	186, 187
				623 3041 21	LUK	FIAT	181, 182
				623 3043 00	LUK	CITROËN	128

*Unique LCV Application







Numerische Liste / Numerical listing / Liste numérique / Listado numérico / Elenco numerico / Listy numerycznej / Перечень артикулов

SCHAEFFLER				SCHAEFFLER			
623 3043 00	LUK	FIAT	151, 152, 154, 155	624 3092 33	LUK	OPEL	446, 447, 452, 453, 457, 458
623 3043 00	LUK	PEUGEOT	479	624 3092 33	LUK	RENAULT	545, 546, 551, 557
623 3043 21	LUK	PEUGEOT	478, 479	624 3092 33	LUK	VAUXHALL	600, 606, 611
623 3082 21	LUK	VW	642, 643, 644, 645, 646, 656, 657, 658	624 3092 34	LUK	NISSAN	402, 407, 408
623 3094 21	LUK	VW	620, 624	624 3092 34	LUK	OPEL	447, 458
623 3124 33	LUK	FORD	214	624 3092 34	LUK	RENAULT	546, 551, 557
623 3141 00	LUK	CITROËN	127	624 3092 34	LUK	VAUXHALL	600, 606, 611
623 3141 00	LUK	PEUGEOT	463, 464	624 3096 00	LUK	FIAT	153, 154
623 3159 09	LUK	NISSAN	403, 408	624 3096 00	LUK	PEUGEOT	467, 468
623 3159 09	LUK	OPEL	448, 454, 459	624 3116 00	LUK	VW	641
623 3159 09	LUK	RENAULT	547, 552, 558	624 3131 00	LUK	VW	641, 642
623 3159 09	LUK	VAUXHALL	601, 602, 607, 608, 612, 613	624 3148 09	LUK	MERCEDES-BENZ	290, 293
623 3159 33	LUK	NISSAN	403, 408	624 3148 33	LUK	MERCEDES-BENZ	290, 291, 292, 293, 294, 296
623 3159 33	LUK	RENAULT	547, 552, 558	624 3148 34	LUK	MERCEDES-BENZ	290, 291, 292, 293, 294
623 3159 34	LUK	NISSAN	403, 408	624 3156 34	LUK	VW	653, 663, 664
623 3159 34	LUK	RENAULT	547, 552, 558	624 3162 09	LUK	MERCEDES-BENZ	357, 358, 359, 360, 361, 362, 363, 366
623 3160 00	LUK	VW	646, 659	624 3162 33	LUK	MERCEDES-BENZ	357, 358, 359, 361, 362, 363, 366
623 3209 00	LUK	VW	620	624 3162 34	LUK	MERCEDES-BENZ	357, 358, 359, 360, 361, 362, 363, 366
623 3234 33	LUK	OPEL	414	624 3165 00	LUK	CITROËN	131, 132, 133, 134
623 3234 33	LUK	VAUXHALL	573	624 3165 00	LUK	FIAT	153, 154, 160, 161, 162, 163, 164, 165
623 3239 00	LUK	VW	619	624 3165 00	LUK	PEUGEOT	467, 468
623 3241 00	LUK	CITROËN	119, 124	624 3178 34	LUK	VW	653, 654, 664, 665
623 3241 00	LUK	PEUGEOT	486, 487, 491	624 3180 34	LUK	VW	621, 622, 623, 625, 626, 627
623 3241 09	LUK	PEUGEOT	489	624 3182 09	LUK	MERCEDES-BENZ	293
623 3241 34	LUK	CITROËN	120, 121	624 3182 33	LUK	MERCEDES-BENZ	291, 292, 293, 294, 296
623 3241 34	LUK	PEUGEOT	487, 488	624 3182 34	LUK	MERCEDES-BENZ	291, 292, 293, 294, 295
623 3296 00	LUK	FIAT	149, 150, 151	624 3214 00	LUK	FIAT	158, 159
623 3323 00	LUK	CITROËN	122	624 3218 00	LUK	CITROËN	115, 116, 118, 119, 120
623 3323 00	LUK	PEUGEOT	489	624 3218 00	LUK	FIAT	178
623 3325 00	LUK	CITROËN	117, 119, 120, 121, 124, 125	624 3218 00	LUK	PEUGEOT	474, 483, 484, 485, 486, 487
623 3325 00	LUK	FIAT	178	624 3218 21	LUK	CITROËN	116, 118, 119
623 3325 00	LUK	PEUGEOT	475, 483, 484, 486, 487, 488, 489, 491	624 3218 21	LUK	PEUGEOT	483, 484, 485, 486, 487
623 3534 00	LUK	VW	617, 618, 630, 631, 632	624 3229 33	LUK	FORD	188, 189
623 3540 00	LUK	FIAT	142, 143, 149, 150, 151	624 3230 34	LUK	VW	621, 625
623 3540 00	LUK	OPEL	416	624 3247 33	LUK	MERCEDES-BENZ	297, 298, 299, 300, 301, 303, 304, 305, 306, 311, 312, 313, 314, 315, 316, 317, 320, 321, 322, 323, 326, 327, 334, 336, 341, 343, 344, 345, 347, 348, 349, 351
623 3540 00	LUK	VAUXHALL	575	624 3267 00	LUK	FIAT	179, 180
623 3542 00	LUK	VW	624	624 3267 00	LUK	PEUGEOT	476, 477
623 3548 00	LUK	VW	630	624 3278 33	LUK	VW	639, 640
623 3553 33	LUK	NISSAN	387	624 3303 00	LUK	CITROËN	135, 136
623 3553 33	LUK	RENAULT	505, 506	624 3303 00	LUK	FIAT	166
623 3701 33	LUK	RENAULT	503	624 3303 00	LUK	PEUGEOT	470
623 3727 00	LUK	CITROËN	117, 122, 123	624 3307 09	LUK	FORD	199
623 3727 00	LUK	PEUGEOT	480, 481, 484, 490	624 3307 33	LUK	FORD	199
623 3734 00	LUK	VW	629	624 3309 00	LUK	FORD	189, 190, 191
623 3741 33	LUK	FORD	186	624 3310 33	LUK	VW	639, 640
623 3765 00	LUK	VW	645, 646, 666, 667, 671, 672, 673	624 3312 09	LUK	NISSAN	377, 401, 402, 404, 405
624 1313 00	LUK	IVECO	222, 223, 224, 225, 226, 227, 229, 230, 232, 236, 237, 239, 241, 242, 252	624 3312 09	LUK	OPEL	418, 422, 444, 450, 455
624 2187 00	LUK	MERCEDES-BENZ	293	624 3312 09	LUK	RENAULT	508, 514, 543, 544, 549, 550, 554, 555
624 3078 00	LUK	FIAT	181, 182	624 3087 09	LUK	VAUXHALL	580, 584, 597, 598, 603, 604, 609
624 3087 09	LUK	NISSAN	377, 401, 402, 404, 405	624 3087 33	LUK	NISSAN	377, 401, 402, 404, 405
624 3087 09	LUK	OPEL	418, 422, 444, 450, 455	624 3087 33	LUK	OPEL	418, 422, 444, 450, 455
624 3087 09	LUK	RENAULT	508, 514, 543, 544, 549, 550, 554, 555	624 3087 33	LUK	RENAULT	508, 514, 543, 544, 549, 550, 554, 555
624 3087 09	LUK	VAUXHALL	580, 584, 597, 598, 603, 604, 609	624 3087 34	LUK	VAUXHALL	580, 584, 597, 598, 603, 604, 609
624 3087 33	LUK	NISSAN	377, 401, 402, 404, 405	624 3087 34	LUK	NISSAN	377, 401, 402, 404, 405
624 3087 33	LUK	OPEL	418, 422, 444, 450, 455	624 3087 34	LUK	OPEL	418, 422, 444, 450, 455
624 3087 33	LUK	RENAULT	508, 514, 543, 544, 549, 550, 554, 555	624 3087 34	LUK	RENAULT	508, 514, 543, 544, 549, 550, 554, 555
624 3087 33	LUK	VAUXHALL	580, 584, 597, 598, 603, 604, 609	624 3087 34	LUK	VAUXHALL	580, 584, 597, 598, 603, 604, 609
624 3087 34	LUK	NISSAN	377, 401, 402, 404, 405	624 3092 09	LUK	NISSAN	402, 407, 408
624 3087 34	LUK	OPEL	418, 422, 444, 450, 455	624 3092 09	LUK	OPEL	446, 447, 452, 453, 457, 458
624 3087 34	LUK	RENAULT	508, 514, 543, 544, 549, 550, 554, 555	624 3092 09	LUK	RENAULT	546, 551, 556, 557
624 3087 34	LUK	VAUXHALL	580, 584, 597, 598, 603, 604, 609	624 3092 09	LUK	VAUXHALL	600, 606, 611
624 3092 09	LUK	NISSAN	402, 407, 408	624 3092 33	LUK	NISSAN	402, 407, 408





*Unique LCV Application

**Numerische Liste / Numerical listing / Liste numérique / Listado numérico / Elenco numerico /
Listy numerycznej / Перечень артикулов**

SCHAEFFLER				SCHAEFFLER			
624 3312 34	LUK	VAUXHALL	580, 585, 598, 603, 604, 609	624 3930 33	LUK	NISSAN	388, 389
624 3390 00	LUK	TOYOTA	564, 565	624 3930 33	LUK	OPEL	460, 461, 462, 463
624 3401 00	LUK	CITROËN	129	624 3930 33	LUK	RENAULT	559, 560, 561, 562, 563
624 3401 00	LUK	FIAT	156, 157, 158	624 3930 33	LUK	VAUXHALL	614, 615
624 3401 00	LUK	PEUGEOT	465	624 3945 09	LUK	NISSAN	403, 408
624 3408 09	LUK	MERCEDES-BENZ	300, 337, 360, 364, 365, 367, 368	624 3945 09	LUK	OPEL	448, 454, 459
624 3408 33	LUK	MERCEDES-BENZ	295, 298, 299, 300, 301, 302, 303, 304, 307, 313, 314, 315, 316, 318, 319, 320, 324, 325, 335, 337, 342, 343, 345, 346, 347, 349, 350, 351, 360, 364, 365, 367, 368, 373, 374	624 3945 09	LUK	RENAULT	547, 552, 558
624 3417 00	LUK	FIAT	181	624 3945 09	LUK	VAUXHALL	601, 602, 607, 608, 612, 613
624 3417 00	LUK	PEUGEOT	478	624 3945 33	LUK	NISSAN	403, 408
624 3476 09	LUK	NISSAN	377, 378, 379, 380, 381, 382, 383, 384, 385, 403, 406, 408, 409	624 3945 33	LUK	OPEL	448, 454, 459
624 3476 09	LUK	OPEL	419, 420, 423, 424, 425, 426, 427, 428, 429, 430, 431, 445, 446, 447, 449, 451, 453, 456, 457, 458	624 3945 33	LUK	RENAULT	547, 553, 558
624 3476 09	LUK	RENAULT	509, 510, 511, 512, 515, 517, 518, 519, 520, 521, 522, 523, 524, 545, 548, 551, 552, 553, 556, 557, 559	624 3945 33	LUK	VAUXHALL	601, 602, 607, 608, 612, 613
624 3476 09	LUK	VAUXHALL	576, 577, 578, 579, 580, 581, 582, 583, 584, 585, 586, 587, 588, 599, 605, 609, 610	624 3945 34	LUK	NISSAN	403, 408
624 3476 33	LUK	NISSAN	377, 378, 379, 380, 381, 382	624 3945 34	LUK	OPEL	448, 454, 459
624 3476 33	LUK	OPEL	419, 420, 424, 426, 428, 429, 431	624 3945 34	LUK	RENAULT	547, 553, 558
624 3476 33	LUK	RENAULT	509, 510, 515, 517, 520, 521, 522	624 3945 34	LUK	VAUXHALL	601, 602, 607, 608, 612, 613
624 3476 33	LUK	VAUXHALL	577, 580, 581, 586	624 3952 33	LUK	FORD	185
624 3476 34	LUK	NISSAN	377, 378, 379, 380, 381, 382, 383, 384, 385, 403, 406, 408, 409	624 3992 33	LUK	CITROËN	127
624 3476 34	LUK	OPEL	419, 420, 421, 423, 424, 425, 426, 427, 428, 429, 430, 431, 432, 445, 446, 447, 449, 451, 453, 456, 457, 458	624 3992 33	LUK	PEUGEOT	492
624 3476 34	LUK	RENAULT	509, 510, 511, 512, 513, 515, 516, 517, 518, 519, 520, 521, 522, 523, 524, 525, 545, 546, 548, 551, 552, 553, 556, 557, 559	624 4011 33	LUK	VW	669, 674, 675
624 3476 34	LUK	VAUXHALL	576, 577, 578, 579, 580, 581, 582, 583, 584, 585, 586, 587, 588, 599, 605, 609, 610	624 4034 09	LUK	FORD	184
624 3517 33	LUK	VW	647, 648, 649, 650, 660, 661, 668, 673, 674	624 4034 09	LUK	FORD	184
624 3528 00	LUK	HYUNDAI	221	624 4034 34	LUK	FORD	184
624 3547 09	LUK	FORD	214, 215	625 3010 00	LUK	TOYOTA	568
624 3547 33	LUK	FORD	214	625 3011 00	LUK	FORD	203
624 3547 34	LUK	FORD	214, 215	625 3015 00	LUK	FORD	192, 193
624 3553 33	LUK	VW	622, 623, 625, 626, 627, 632, 633, 634, 635	625 3022 00	LUK	FORD	191, 192, 193
624 3703 33	LUK	VW	636, 637, 638	625 3023 00	LUK	CITROËN	130
624 3731 09	LUK	VW	621, 622, 623, 625, 626, 627	625 3023 00	LUK	PEUGEOT	466
624 3731 33	LUK	VW	621, 622, 623, 625, 626, 627, 632, 633, 634, 635	625 3044 00	LUK	FORD	203, 204
624 3739 33	LUK	FORD	183	625 3044 33	LUK	FORD	194, 196
624 3742 33	LUK	FIAT	142, 143, 144	625 3061 33	LUK	FORD	197, 201, 202
624 3742 33	LUK	OPEL	416	625 3068 00	LUK	FORD	203, 204
624 3742 33	LUK	VAUXHALL	575	625 3106 00	LUK	NISSAN	376
624 3751 09	LUK	FIAT	165	625 3145 09	LUK	FIAT	171, 174
624 3762 09	LUK	MERCEDES-BENZ	373, 374	625 3145 33	LUK	FIAT	167, 168, 169, 170, 171, 172, 173, 174
624 3762 33	LUK	MERCEDES-BENZ	373, 374	625 3165 09	LUK	FIAT	167, 168, 169, 170, 171
624 3774 33	LUK	FORD	184	625 3199 09	LUK	NISSAN	376
624 3777 00	LUK	GAZ	216, 217	625 3201 00	LUK	NISSAN	376, 377
624 3783 33	LUK	VW	651, 662, 663, 670, 675, 676	626 3015 60	LUK	TOYOTA	564, 565, 566, 567
624 3898 00	LUK	FIAT	180	626 3026 19	LUK	MERCEDES-BENZ	332
624 3898 00	LUK	PEUGEOT	475, 477	626 3026 33	LUK	MERCEDES-BENZ	308, 309, 327, 328, 329, 330, 331, 332, 333, 338, 339, 352, 353, 354, 355
624 3930 09	LUK	FIAT	182, 183	626 3032 00	LUK	CITROËN	136
624 3930 33	LUK	MERCEDES-BENZ	373	626 3032 00	LUK	PEUGEOT	471
				626 3033 09	LUK	FIAT	167, 168, 169, 171, 172
				626 3033 33	LUK	CITROËN	138
				626 3033 33	LUK	FIAT	167, 168, 169, 170, 171, 172, 173, 174, 175
				626 3033 33	LUK	PEUGEOT	472, 473, 474
				626 3034 33	LUK	FORD	193, 203, 204, 205, 206, 207, 208
				626 3045 00	LUK	HYUNDAI	217, 218, 219, 220, 221
				626 3045 09	LUK	HYUNDAI	217, 218, 219, 220, 221
				626 3049 09	LUK	NISSAN	390, 391, 392, 393, 395, 397, 398, 399, 401
				626 3049 09	LUK	OPEL	432, 433, 435, 436, 437, 440, 443
				626 3049 09	LUK	RENAULT	526, 529, 530, 534, 535, 536, 538, 542
				626 3049 09	LUK	VAUXHALL	588, 591, 595, 597
				626 3049 33	LUK	NISSAN	390, 391, 392, 393, 394, 395, 396, 397, 398, 399, 400, 401
				626 3049 33	LUK	OPEL	433, 434, 435, 437, 438, 439, 440, 441, 442
				626 3049 33	LUK	RENAULT	526, 527, 528, 529, 530, 532, 533, 534, 535, 536, 537, 538, 539, 540, 541, 542
				626 3049 33	LUK	VAUXHALL	588, 591, 592, 593, 594, 595
				626 3050 00	LUK	NISSAN	392, 393, 394, 395, 396, 398, 399, 400
				626 3050 00	LUK	OPEL	433, 436, 440, 443





*Unique LCV Application

**Numerische Liste / Numerical listing / Liste numérique / Listado numérico / Elenco numerico /
Listy numerycznej / Перечень артикулов**

SCHAEFFLER				SCHAEFFLER			
626 3050 00	LUK	RENAULT	527, 528, 531, 533, 534, 535, 536, 537, 539, 540, 541	713 6106 10	FAG	VW	615, 616, 617, 618, 619, 620, 621, 622, 623, 624, 625, 626, 627, 628, 629, 630, 631, 632, 633, 634, 635
626 3050 00	LUK	VAUXHALL	589, 592	713 6107 60	FAG	VW	642, 643, 644, 645, 646, 647, 648, 649, 650, 651, 652, 653, 654, 655, 656, 657, 658, 659, 660, 661, 662, 663, 664, 665, 666, 667, 668, 669, 670, 671, 672, 673, 674, 675, 676, 677
626 3053 09	LUK	FORD	193, 206, 207, 208	713 6108 30	FAG	VW	615, 616, 617, 618, 619, 620, 621, 622, 623, 624, 626, 628, 629, 630, 631, 632, 634, 635
626 3053 33	LUK	FORD	193, 203, 204, 205, 206, 207, 208	713 6109 90	FAG	VW	615, 616, 617, 618, 619, 620, 621, 622, 623, 624, 626, 628
626 3072 33	LUK	VW	640	713 6157 30	FAG	FORD	186, 187
626 3075 00	LUK	CITROËN	134, 135, 136, 137	713 6183 00	FAG	TOYOTA	563, 564, 565, 566, 567, 568
626 3075 00	LUK	PEUGEOT	469, 471, 472	713 6188 80	FAG	TOYOTA	564, 565, 566, 567, 568
626 3093 33	LUK	FORD	188, 194, 197, 202, 211, 212, 213	713 6188 90	FAG	TOYOTA	564, 565, 566, 567, 568
626 3130 33	LUK	VW	638, 639	713 6190 70	FAG	HYUNDAI	220, 221, 222
627 3031 33	LUK	FORD	209	713 6193 00	FAG	HYUNDAI	220, 221, 222
627 3032 35	LUK	FORD	195, 198, 200, 201, 211, 212, 213, 214	713 6193 00	FAG	HYUNDAI	220, 221, 222
627 3040 33	LUK	FORD	195, 198, 200, 201, 211, 212, 213, 214	713 6194 00	FAG	HYUNDAI	220, 221, 222
627 3051 00	LUK	IVECO	277, 281, 282, 283, 284	713 6197 30	FAG	HYUNDAI	220, 221, 222
627 3064 00	LUK	IVECO	224, 233	713 6211 30	FAG	TOYOTA	569
628 3166 00	LUK	HYUNDAI	217, 218, 219, 220, 221	713 6267 90	FAG	HYUNDAI	217, 218, 219, 220, 221
628 3182 00	LUK	IVECO	228, 230, 236, 237, 238, 240, 241, 242, 243, 244, 250, 252, 253, 254, 255, 276, 277, 278	713 6300 30	FAG	RENAULT	496, 497, 498, 499, 500, 501, 502
628 3183 00	LUK	RENAULT	514	713 6302 70	FAG	RENAULT	496, 497, 498, 499, 500, 501, 502
628 3191 00	LUK	IVECO	229, 230, 233, 234, 236, 248, 249, 250, 251, 258, 259, 261, 264, 265, 266, 268, 269, 272, 273, 274, 275, 279, 280, 286, 287, 288	713 6305 30	FAG	CITROËN	114, 115, 116, 118, 125
628 3294 09	LUK	FUSO (MITSU- BISHI)	216	713 6305 30	FAG	PEUGEOT	482, 483, 485, 493, 494
628 3294 09	LUK	MITSUBISHI	375	713 6305 70	FAG	FIAT	182
628 3319 00	LUK	MITSUBISHI	375	713 6305 70	FAG	PEUGEOT	479
628 3332 00	LUK	IVECO	228, 231, 232, 234, 235, 244, 245, 246, 247, 248, 251, 255, 256, 257, 260, 261, 262, 263, 264, 266, 267, 268, 270, 271, 272, 274, 275, 279, 281, 284, 285, 287, 288, 289	713 6305 80	FAG	FIAT	182
628 3342 00	LUK	NISSAN	377	713 6305 80	FAG	PEUGEOT	479
628 3362 00	LUK	NISSAN	377	713 6306 90	FAG	RENAULT	496, 497, 498, 499, 500, 501, 502
628 3374 09	LUK	FUSO (MITSU- BISHI)	216	713 6307 60	FAG	PEUGEOT	481, 484, 485, 486, 487, 488, 489, 490, 491, 492, 493
630 3131 09	LUK	FUSO (MITSU- BISHI)	216	713 6307 80	FAG	NISSAN	377, 378, 379, 380, 381, 382, 383, 384, 385, 386
630 3131 09	LUK	MITSUBISHI	375, 376	713 6307 80	FAG	OPEL	418, 419, 420, 421, 422, 423, 424, 425, 426, 427, 428, 429, 430, 431, 432
630 3146 00	LUK	MITSUBISHI	375	713 6307 80	FAG	RENAULT	508, 509, 510, 511, 512, 513, 514, 515, 516, 517, 518, 519, 520, 521, 522, 523, 524, 525, 526
630 3149 09	LUK	MITSUBISHI	376	713 6307 80	FAG	VAUXHALL	576, 577, 578, 579, 580, 581, 582, 583, 584, 585, 586, 587, 588
630 3157 00	LUK	MITSUBISHI	375	713 6307 90	FAG	NISSAN	377, 378, 379, 380, 381, 382, 383, 384, 385
631 3174 00	LUK	IVECO	280, 287	713 6307 90	FAG	OPEL	418, 419, 420, 421, 422, 423, 424, 425, 426, 427, 428, 429, 430, 431, 432
711 0244 10	INA	VW	615, 616, 629	713 6307 90	FAG	RENAULT	508, 509, 510, 511, 512, 513, 514, 515, 516, 517, 518, 519, 520, 521, 522, 523, 524, 525, 526
711 0294 10	INA	VW	628, 629, 650, 652, 662, 669, 675, 676	713 6308 00	FAG	NISSAN	377, 378, 379, 380, 381, 382, 384, 385, 386
711 0308 10	INA	FORD	184, 186	713 6308 00	FAG	OPEL	418, 419, 420, 421, 422, 423, 424, 425, 426, 427, 428, 429, 430, 431, 432
713 0014 20	FAG	FIAT	178, 179, 180, 181, 182	713 6308 00	FAG	VAUXHALL	576, 577, 578, 579, 580, 581, 582, 583, 584, 585, 586, 587, 588
713 0014 20	FAG	PEUGEOT	475, 476, 477, 478, 479	713 6308 00	FAG	NISSAN	377, 378, 379, 380, 381, 382, 384, 385, 386
713 0071 20	FAG	FIAT	145, 148, 149, 150	713 6308 00	FAG	OPEL	418, 419, 420, 421, 422, 423, 424, 425, 426, 427, 428, 429, 430, 431, 432
713 0079 20	FAG	VW	666, 667, 668, 669, 670, 671, 672, 673, 674, 675, 676, 677	713 6308 00	FAG	RENAULT	509, 510, 512, 513, 514, 516, 517, 518, 519, 520, 521, 522, 523, 524, 525, 526
713 0087 20	FAG	MERCEDES- BENZ	357, 358, 359, 360, 361, 362, 363, 364, 365, 366, 367, 368, 369, 370, 371, 372, 373	713 6308 00	FAG	VAUXHALL	576, 577, 578, 579, 580, 581, 582, 583, 584, 585, 586, 587, 588
713 0390 20	FAG	FORD	188, 189, 190, 191, 192, 193, 194	713 6308 10	FAG	NISSAN	377, 378, 379, 380, 381, 382, 384, 385, 386
713 0392 20	FAG	RENAULT	498, 500, 502	713 6308 10	FAG	OPEL	418, 419, 420, 421, 422, 423, 424, 425, 426, 427, 428, 429, 430, 431, 432
713 0396 20	FAG	PEUGEOT	484, 486, 487, 489, 490, 491, 492	713 6308 10	FAG	VAUXHALL	576, 577, 578, 579, 580, 581, 582, 583, 584, 585, 586, 587, 588
713 0400 20	FAG	CITROËN	128, 129, 130, 131, 132, 133, 134	713 6308 10	FAG	NISSAN	377, 378, 379, 380, 381, 382, 384, 385, 386
713 0400 20	FAG	FIAT	155, 156, 157, 158, 159, 160, 161, 162, 163, 164, 165	713 6308 10	FAG	OPEL	418, 419, 420, 421, 422, 423, 424, 425, 426, 427, 428, 429, 430, 431, 432
713 0400 20	FAG	PEUGEOT	465, 466, 467, 468, 469	713 6308 10	FAG	VAUXHALL	576, 577, 578, 579, 580, 581, 582, 583, 584, 585, 586, 587, 588
713 0406 20	FAG	MERCEDES- BENZ	357, 358, 359, 360, 361, 362, 363, 364, 365, 366, 367, 368, 369, 370, 371, 372, 373	713 6308 10	FAG	NISSAN	377, 378, 379, 380, 381, 382, 384, 385, 386
713 6063 90	FAG	FIAT	177, 178	713 6308 10	FAG	OPEL	418, 419, 420, 421, 422, 423, 424, 425, 426, 427, 428, 429, 430, 431, 432
713 6064 00	FAG	FIAT	145, 146, 147, 148, 149, 150, 151, 176, 177				

*Unique LCV Application





**Numerische Liste / Numerical listing / Liste numérique / Listado numérico / Elenco numerico /
Listy numerycznej / Перечень артикулов**

SCHAEFFLER				SCHAEFFLER			
713 6308 10	FAG	RENAULT	509, 510, 512, 513, 514, 516, 517, 518, 519, 520, 521, 522, 523, 524, 525, 526	713 6441 30	FAG	VAUXHALL	598, 599, 600, 601, 602, 603, 604, 605, 606, 607, 608, 609, 610, 611, 612, 613
713 6308 10	FAG	VAUXHALL	576, 577, 578, 579, 580, 581, 582, 583, 584, 585, 586, 587, 588	713 6441 40	FAG	NISSAN	402, 403, 404, 405, 406, 407, 408, 409, 410
713 6308 40	FAG	RENAULT	495, 503, 504, 505, 506, 507, 508	713 6441 40	FAG	OPEL	444, 445, 446, 447, 448, 449, 450, 451, 452, 453, 454, 455, 456, 457, 458, 459, 460
713 6309 00	FAG	RENAULT	495, 503, 504, 505, 506, 507, 508	713 6441 40	FAG	RENAULT	543, 544, 545, 546, 547, 548, 549, 550, 551, 552, 553, 554, 555, 556, 557, 558, 559
713 6309 20	FAG	RENAULT	501, 502, 503	713 6441 40	FAG	VAUXHALL	598, 599, 600, 601, 602, 603, 604, 605, 606, 607, 608, 609, 610, 611, 612, 613
713 6309 80	FAG	RENAULT	496, 497, 498, 499, 500, 501, 502	713 6442 90	FAG	NISSAN	402, 403, 404, 405, 406, 407, 408, 409, 410
713 6330 30	FAG	NISSAN	386, 387, 388	713 6442 90	FAG	OPEL	444, 445, 446, 447, 448, 449, 450, 451, 452, 453, 454, 455, 456, 457, 458, 459, 460
713 6330 40	FAG	NISSAN	386, 387, 388	713 6442 90	FAG	RENAULT	543, 544, 545, 546, 547, 548, 549, 550, 551, 552, 553, 554, 555, 556, 557, 558, 559
713 6401 80	FAG	CITROËN	114, 115, 116, 118, 125	713 6442 90	FAG	VAUXHALL	598, 599, 600, 601, 602, 603, 604, 605, 606, 607, 608, 609, 610, 611, 612, 613
713 6401 80	FAG	PEUGEOT	482, 483, 485, 493, 494	713 6442 90	FAG	NISSAN	402, 403, 404, 405, 406, 407, 408, 409, 410
713 6403 30	FAG	CITROËN	127, 128, 129, 130, 131, 132, 134	713 6442 90	FAG	OPEL	444, 445, 446, 447, 448, 449, 450, 451, 452, 453, 454, 455, 456, 457, 458, 459, 460
713 6403 30	FAG	FIAT	152, 153, 154, 155, 156, 157, 158, 159, 160, 162, 164, 165	713 6442 90	FAG	RENAULT	543, 544, 545, 546, 547, 548, 549, 550, 551, 552, 553, 554, 555, 556, 557, 558, 559
713 6403 30	FAG	PEUGEOT	464, 465, 466, 467, 469	713 6442 90	FAG	VAUXHALL	598, 599, 600, 601, 602, 603, 604, 605, 606, 607, 608, 609, 610, 611, 612, 613
713 6403 90	FAG	CITROËN	127, 128, 129, 130, 131, 132, 133, 134	713 6445 50	FAG	OPEL	410, 411, 412, 413, 414
713 6403 90	FAG	FIAT	152, 153, 154, 155, 156, 157, 158, 159, 160, 161, 162, 163, 164, 165	713 6445 50	FAG	VAUXHALL	569, 570, 571, 572, 573, 574
713 6403 90	FAG	PEUGEOT	464, 465, 466, 467, 468, 469	713 6445 60	FAG	OPEL	411, 412, 413
713 6404 00	FAG	CITROËN	127, 128, 129, 130, 131, 132, 133, 134	713 6445 60	FAG	VAUXHALL	570, 571, 572, 573, 574
713 6404 00	FAG	FIAT	152, 153, 154, 155, 156, 157, 158, 159, 160, 161, 162, 163, 164, 165	713 6445 70	FAG	OPEL	413, 414
713 6404 00	FAG	PEUGEOT	464, 465, 466, 467, 468, 469	713 6446 70	FAG	OPEL	414
713 6404 20	FAG	CITROËN	114, 115, 125	713 6450 30	FAG	NISSAN	393, 394, 395, 396, 397, 398, 399, 400
713 6404 20	FAG	PEUGEOT	482, 493, 494	713 6450 30	FAG	OPEL	433, 434, 435, 436, 439, 440, 441, 442, 443
713 6404 50	FAG	CITROËN	114, 115	713 6450 30	FAG	RENAULT	527, 528, 531, 532, 533, 535, 537, 540, 541
713 6404 50	FAG	PEUGEOT	482, 493, 494	713 6450 30	FAG	VAUXHALL	589, 590, 592, 593, 595, 596
713 6404 60	FAG	CITROËN	114, 115, 116, 118	713 6450 40	FAG	NISSAN	390, 391, 392, 393, 394, 395, 396, 397, 398, 399, 400, 401
713 6404 60	FAG	PEUGEOT	482, 483, 485, 493, 494	713 6450 40	FAG	OPEL	433, 434, 435, 436, 437, 438, 439, 440, 441, 442, 443
713 6405 20	FAG	FIAT	178, 179, 180, 181	713 6450 40	FAG	RENAULT	526, 527, 528, 529, 530, 531, 532, 533, 534, 535, 536, 537, 538, 539, 540, 541, 542
713 6405 20	FAG	PEUGEOT	475, 476, 477, 478, 479	713 6450 40	FAG	VAUXHALL	589, 590, 591, 592, 593, 594, 595, 596, 597
713 6405 30	FAG	FIAT	178, 179, 180, 181	713 6450 50	FAG	NISSAN	390, 391, 392, 393, 394, 395, 396, 397, 398, 399, 400, 401
713 6405 30	FAG	PEUGEOT	475, 476, 477, 478, 479	713 6450 50	FAG	OPEL	433, 434, 435, 436, 437, 438, 439, 440, 441, 442, 443
713 6405 40	FAG	FIAT	178, 179, 180, 181	713 6450 50	FAG	RENAULT	526, 527, 528, 529, 530, 531, 532, 533, 534, 536, 538, 539, 540, 541, 542
713 6405 40	FAG	PEUGEOT	475, 476, 477, 478, 479, 480, 481	713 6450 50	FAG	VAUXHALL	589, 590, 591, 593, 594, 596, 597
713 6405 50	FAG	CITROËN	134, 135, 136, 137, 138, 139	713 6451 60	FAG	NISSAN	393, 394, 395, 396, 397, 398, 399, 400
713 6405 50	FAG	FIAT	165, 166, 167, 168, 169, 170, 171, 172, 173, 174, 175	713 6451 60	FAG	OPEL	433, 434, 435, 436, 439, 440, 441, 442, 443
713 6405 50	FAG	PEUGEOT	469, 470, 471, 472, 473, 474	713 6451 60	FAG	RENAULT	527, 528, 531, 532, 533, 535, 537, 540, 541
713 6405 60	FAG	CITROËN	134, 135, 136, 137, 138, 139	713 6451 60	FAG	VAUXHALL	589, 590, 592, 593, 594, 595, 596
713 6405 60	FAG	FIAT	165, 166, 167, 168, 169, 170, 171, 172, 173, 174, 175, 176	713 6451 90	FAG	NISSAN	388, 389
713 6405 60	FAG	PEUGEOT	469, 470, 471, 472, 473, 474	713 6451 90	FAG	OPEL	460, 461, 462, 463
713 6405 70	FAG	CITROËN	134, 135, 136, 137, 138, 139	713 6451 90	FAG	RENAULT	560, 561, 562, 563
713 6405 70	FAG	FIAT	165, 166, 167, 168, 169, 170, 171, 172, 173, 174, 175, 176	713 6451 90	FAG	VAUXHALL	614, 615
713 6405 70	FAG	PEUGEOT	469, 470, 471, 472, 473, 474	713 6503 10	FAG	FIAT	152, 153, 154
713 6406 10	FAG	CITROËN	114, 117, 118, 119, 120, 121, 122, 123, 124, 125, 126, 127	713 6503 10	FAG	PEUGEOT	464
713 6406 10	FAG	PEUGEOT	481, 484, 485, 486, 487, 488, 489, 490, 491, 492, 493	713 6503 30	FAG	FIAT	152, 153, 154
713 6440 80	FAG	OPEL	410, 411, 412, 413, 414	713 6503 30	FAG	PEUGEOT	464
713 6440 80	FAG	VAUXHALL	569, 570, 571, 572, 573, 574	713 6504 20	FAG	FIAT	152, 153, 154
713 6441 20	FAG	NISSAN	402, 403, 404, 405, 406, 407	713 6504 20	FAG	PEUGEOT	464
713 6441 20	FAG	OPEL	444, 445, 446, 447, 448, 449, 450, 451, 452, 453, 454, 455, 456, 457, 458, 459, 460	713 6504 30	FAG	FIAT	152, 153, 154
713 6441 20	FAG	RENAULT	543, 544, 546, 549, 550, 552, 554, 555, 557, 558	713 6504 30	FAG	PEUGEOT	464
713 6441 20	FAG	VAUXHALL	598, 599, 600, 601, 602, 603, 604, 605, 606, 607, 608, 609, 610, 611, 612, 613				
713 6441 30	FAG	NISSAN	402, 403, 404, 405, 406, 407				
713 6441 30	FAG	OPEL	444, 445, 446, 447, 448, 449, 450, 451, 452, 453, 454, 455, 456, 457, 458, 459, 460				
713 6441 30	FAG	RENAULT	543, 544, 546, 549, 550, 552, 554, 555, 557, 558				

*Unique LCV Application







**Numerische Liste / Numerical listing / Liste numérique / Listado numérico / Elenco numerico /
Listy numerycznej / Перечень артикулов**

SCHAEFFLER				SCHAEFFLER			
713 6505 30	FAG	FIAT	182	713 6791 30	FAG	FORD	210, 211, 212, 213
713 6505 30	FAG	PEUGEOT	479	713 6791 40	FAG	FORD	210, 211, 212, 213
713 6670 10	FAG	MERCEDES- BENZ	291, 292, 294, 295	713 6791 50	FAG	FORD	187, 188, 210, 211, 212, 213
713 6670 30	FAG	MERCEDES- BENZ	291, 292, 294, 295	713 6791 60	FAG	FORD	187, 188, 210, 211, 212, 213
713 6670 30	FAG	VW	641, 642	713 6791 80	FAG	FORD	184, 185, 186
713 6670 40	FAG	VW	641, 642	713 6792 30	FAG	FORD	186, 187
713 6676 00	FAG	VW	641, 642	713 6905 10	FAG	FIAT	145, 146, 147, 148, 149, 150, 151
713 6679 80	FAG	MERCEDES- BENZ	357, 358, 359, 360, 361, 362, 363, 364, 365, 366, 367, 368, 369, 370, 371, 372, 373	713 6907 10	FAG	FIAT	176, 177, 178
713 6680 10	FAG	MERCEDES- BENZ	295, 296, 297, 298, 299, 300, 301, 302, 303, 304, 305, 306, 307, 308, 309, 310, 311, 312, 313, 314, 315, 317, 318, 319, 320, 321, 322, 323, 324, 325, 326, 327, 328, 331, 332, 334, 335, 336, 337, 338, 339, 340, 341, 342, 343, 344, 345, 346, 347, 348, 349, 350, 351, 352, 353, 354, 355, 356, 357	713 6907 30	FAG	FIAT	145, 146, 147, 148, 149, 150, 151
713 6680 10	FAG	VW	636, 637, 638, 639, 640, 641	713 6908 00	FAG	FIAT	139, 140, 141, 142, 143, 144
713 6680 20	FAG	MERCEDES- BENZ	295, 296, 297, 298, 299, 300, 301, 302, 303, 304, 305, 306, 307, 308, 309, 310, 311, 312, 313, 314, 315, 317, 318, 319, 320, 321, 322, 323, 324, 325, 326, 327, 328, 331, 332, 334, 335, 336, 337, 338, 339, 340, 341, 342, 343, 344, 345, 346, 347, 348, 349, 350, 351, 352, 353, 354, 355, 356, 357	713 6908 00	FAG	OPEL	415, 416, 417
713 6680 20	FAG	VW	636, 637, 638, 639, 640, 641	713 6908 00	FAG	VAUXHALL	574, 575, 576
713 6680 30	FAG	MERCEDES- BENZ	316, 319, 320, 322, 323, 325, 326, 329, 330, 332, 333, 344, 345, 346, 347, 349, 351, 353, 354, 355, 356	713 6908 10	FAG	FIAT	141, 142, 143, 144
713 6680 40	FAG	MERCEDES- BENZ	295, 296, 341, 342, 343, 344, 345, 346, 347, 348, 349, 350, 351, 352, 353, 354, 355, 356, 357	713 6908 10	FAG	OPEL	415, 416, 417, 418
713 6680 40	FAG	VW	636, 637, 638, 639, 640, 641	713 6908 10	FAG	VAUXHALL	574, 575, 576
713 6680 50	FAG	MERCEDES- BENZ	357, 358, 359, 361, 362, 363, 364, 366, 367, 369, 370, 371, 372, 373	713 6909 30	FAG	FIAT	155, 156, 157, 158, 159, 160, 161, 162, 163, 164, 165
713 6681 10	FAG	MERCEDES- BENZ	297, 298, 299, 300, 301, 302, 303, 304, 305, 306, 307, 308, 309, 310, 311, 312, 313, 314, 315, 316, 317, 318, 319, 320, 321, 322, 323, 324, 325, 326, 327, 328, 329, 330, 331, 332, 333, 334, 335, 336, 337, 338, 339, 340, 341	713 6909 40	FAG	FIAT	155, 156, 157, 158, 159, 160, 161, 162, 163, 164, 165
713 6784 20	FAG	FORD	190, 191, 192, 193, 194	713 6909 60	FAG	CITROËN	131, 133
713 6786 50	FAG	FORD	188, 189, 190, 191, 192, 193, 194	713 6909 60	FAG	FIAT	157, 161, 163
713 6786 60	FAG	FORD	188, 189	713 6909 60	FAG	PEUGEOT	468
713 6787 20	FAG	FORD	188, 189	713 6909 80	FAG	FIAT	139, 140, 141, 142, 143, 144
713 6788 70	FAG	FORD	214, 215, 216	713 6909 80	FAG	OPEL	415, 416, 417, 418
713 6788 80	FAG	FORD	214, 215, 216	713 6909 80	FAG	VAUXHALL	574, 575, 576
713 6788 90	FAG	FORD	214, 215, 216	713 6909 90	FAG	FIAT	139, 140, 141, 142, 143, 144
713 6789 00	FAG	FORD	194, 195, 196, 197, 198, 199, 200, 201, 202, 203, 204, 205, 206, 207, 208, 209, 210	713 6909 90	FAG	OPEL	415, 416, 417, 418
713 6789 10	FAG	FORD	194, 195, 196, 197, 198, 199, 200, 201, 202, 203, 204, 205, 206, 207, 208, 209, 210	713 6909 90	FAG	VAUXHALL	574, 575, 576
713 6789 20	FAG	FORD	194, 195, 196, 197, 199, 200, 202	713 6910 20	FAG	IVECO	222, 223, 224, 225, 226
713 6789 30	FAG	FORD	194, 195, 196, 197, 199, 200, 202	713 6910 30	FAG	IVECO	222, 223, 224, 225, 226, 227, 228, 229, 230, 231, 232, 233, 251
713 6789 70	FAG	FORD	184, 185, 186	713 6910 40	FAG	IVECO	235, 236
713 6791 00	FAG	FORD	195, 198, 199, 200, 201, 203, 204, 205, 206, 207, 208, 209, 210	713 6910 90	FAG	IVECO	235, 236, 267, 268, 269, 270, 271, 272, 273, 274, 275, 276, 279, 280, 281, 284, 285, 286, 287, 288, 289
713 6791 10	FAG	FORD	195, 198, 199, 200, 201, 203, 204, 205, 206, 207, 208, 209, 210	713 6911 10	FAG	IVECO	231, 236, 237, 238, 239, 240, 241, 242, 243, 244, 245, 246, 248, 249, 250, 251, 252, 253, 255, 256, 257, 258, 276, 277, 278, 279, 280, 281, 282, 283, 284, 285, 286, 287, 289
713 6791 20	FAG	FORD	187, 188, 210, 211, 212, 213, 214	713 6911 20	FAG	IVECO	226, 227, 228, 229, 230, 231, 232, 233, 234, 235, 236, 237, 238, 239, 240, 241, 242, 243, 244, 245, 246, 247, 248, 249, 250, 251, 252, 253, 254, 255, 256, 257, 258, 259, 260, 261, 262, 263, 264, 265, 266, 276, 277, 278, 279, 280, 281, 282, 283, 284, 285, 286, 287, 288, 289
				755321	RUV	FORD	215, 216
				755321	RUV	OPEL	444, 445, 447, 449, 456, 458, 460
				755477	RUV	VW	629
				75735S	RUV	VW	633
				75924S	RUV	PEUGEOT	493
				771 0016 30	FAG	VW	615, 616, 618, 619, 620, 621, 622, 624, 625
				771 0036 30	FAG	CITROËN	128, 129, 130, 131, 132, 133, 134
				771 0036 30	FAG	FIAT	152, 153, 154, 155, 156, 157, 158, 159, 160, 161, 162, 163, 164, 165
				771 0036 30	FAG	PEUGEOT	464, 465, 466, 467, 468, 469
				771 0052 30	FAG	CITROËN	128

*Unique LCV Application





**Numerische Liste / Numerical listing / Liste numérique / Listado numérico / Elenco numerico /
Listy numerycznej / Перечень артикулов**

SCHAEFFLER				SCHAEFFLER			
771 0052 30	FAG	FIAT	153, 155, 156, 158, 159, 162, 163	772 0250 30	FAG	VW	615, 616, 617, 618, 619, 622, 624, 629, 630, 631
771 0054 30	FAG	PEUGEOT	479	772 0254 30	FAG	CITROËN	128, 129, 130, 131, 132, 133, 134
771 0055 30	FAG	FIAT	182	772 0254 30	FAG	FIAT	152, 153, 154, 155, 156, 157, 158, 159, 160, 161, 162, 163, 164, 165
771 0059 30	FAG	FIAT	182	772 0254 30	FAG	PEUGEOT	464, 465, 466, 467, 468, 469
771 0060 30	FAG	CITROËN	127, 128, 129, 130, 131, 132, 133, 134	772 0256 30	FAG	FIAT	154, 157, 161, 163
771 0060 30	FAG	FIAT	152, 153, 154, 155, 156, 157, 158, 159, 160, 161, 162, 163, 164, 165	772 0259 30	FAG	FIAT	182
771 0060 30	FAG	PEUGEOT	464, 465, 466, 467, 468, 469	772 0274 30	FAG	FIAT	145, 149
771 0065 30	FAG	CITROËN	128, 129, 131, 132, 133	772 0276 30	FAG	FIAT	140, 141, 147, 148, 178
771 0065 30	FAG	FIAT	152, 153, 155, 156, 157, 158, 159, 162, 163	772 0283 30	FAG	CITROËN	115
771 0065 30	FAG	PEUGEOT	465, 466, 468	772 0285 30	FAG	CITROËN	115
771 0073 30	FAG	FIAT	140, 141, 145, 147, 148, 149	772 0286 30	FAG	CITROËN	115
771 0075 30	FAG	FIAT	140, 141	772 0292 30	FAG	CITROËN	115, 125
771 0077 30	FAG	FIAT	176, 177	772 0292 30	FAG	PEUGEOT	483
771 0078 30	FAG	FIAT	145, 146, 150, 151	772 0295 30	FAG	CITROËN	115
771 0146 30	FAG	CITROËN	116, 118	772 0296 30	FAG	FIAT	156, 158, 159, 162, 163
771 0285 30	FAG	OPEL	411, 412, 413, 414	772 0322 30	FAG	FIAT	141, 142, 143
771 0285 30	FAG	VAUXHALL	570, 571, 572	772 0327 30	FAG	CITROËN	128, 129, 130, 131, 132, 133, 134
771 0292 30	FAG	NISSAN	377, 378, 379, 381, 382, 386	772 0327 30	FAG	FIAT	152, 153, 156, 157, 159, 162
771 0292 30	FAG	OPEL	418, 421, 423, 424, 429, 432	772 0327 30	FAG	PEUGEOT	465, 466, 467, 468
771 0292 30	FAG	RENAULT	508, 511, 515, 516, 518, 523	772 0341 30	FAG	CITROËN	115
771 0292 30	FAG	VAUXHALL	578, 582, 587	772 0431 30	FAG	VW	643, 644, 645, 646, 647, 648, 649, 651, 657, 658, 659, 660, 661, 663
771 0344 30	FAG	VW	624, 631	772 0432 30	FAG	VW	645, 646, 648, 649, 650, 651, 652, 653, 654, 655, 656, 660, 661, 662, 663, 664, 665, 666
771 0360 30	FAG	VW	615, 616, 617, 618, 619, 622, 624, 629, 630, 631	772 0434 30	FAG	VW	615, 616, 618, 619, 620, 621, 622, 624, 625
771 0411 30	FAG	FORD	214, 215, 216	772 0437 30	FAG	FIAT	145, 146, 147, 150, 151, 176, 177
771 0419 30	FAG	VW	642, 643, 644, 645, 646, 647, 649, 651, 657, 658, 659, 661, 663	772 0440 30	FAG	VW	621, 626, 628
771 0436 30	FAG	CITROËN	116, 118	772 0444 30	FAG	CITROËN	116, 117, 118, 119, 120, 121, 122, 123, 124, 125, 126, 127
771 0436 30	FAG	PEUGEOT	483, 485, 488	772 0444 30	FAG	PEUGEOT	480, 481, 483, 485, 488, 489, 491, 492, 493
771 0476 30	FAG	VW	645, 646, 648, 649, 650, 651, 652, 653, 654, 655, 656, 660, 661, 662, 663, 664, 665, 666	772 0445 30	FAG	VW	615, 616, 618, 619, 620, 621, 623, 624, 625, 626, 627
771 0477 30	FAG	VW	642, 643, 644, 645, 646, 647, 648, 649, 651, 657, 658, 659, 660, 661, 663	772 0447 30	FAG	VW	643, 644, 645, 647, 654, 657, 658, 659
771 0500 30	FAG	RENAULT	498	772 0457 30	FAG	VW	643, 644, 645, 646, 647, 649, 651, 657, 658, 659, 661, 663, 666, 667, 671, 672, 673
771 0507 30	FAG	NISSAN	404, 405, 406, 407, 408	772 0458 30	FAG	VW	648, 649, 650, 651, 652, 653, 654, 655, 660, 661, 662, 663, 664, 665, 666, 668, 669, 670, 671, 672, 673, 674, 675, 676
771 0507 30	FAG	OPEL	444, 445, 447, 449, 450, 451, 452, 453, 455, 456, 458, 460	772 0460 30	FAG	RENAULT	498
771 0507 30	FAG	RENAULT	544, 546, 550, 551, 552, 555, 557	772 0491 30	FAG	VW	624, 631
771 0507 30	FAG	VAUXHALL	598, 599, 600, 601, 604, 606, 607, 609, 611	772 0496 30	FAG	VW	615, 616, 618, 619, 627, 628, 630, 631, 632, 633, 634, 635
771 0511 30	FAG	VW	642, 643, 644, 647, 654, 657, 658, 659	812 0001 10	FAG	RENAULT	496, 497, 498, 499, 501, 502
771 0512 30	FAG	VW	653, 654, 655, 656, 664, 665	812 0002 10	FAG	RENAULT	496, 497, 498, 499, 501, 502
771 0537 30	FAG	MERCEDES-BENZ	357, 358, 359, 360, 361, 362, 363, 364	812 0003 10	FAG	RENAULT	496, 497, 498, 499, 501, 502
771 0552 30	FAG	CITROËN	138, 139	812 0004 10	FAG	RENAULT	496, 497, 498, 499, 501, 502
771 0552 30	FAG	FIAT	165, 172, 173, 174, 175, 176	813 0001 30	FAG	RENAULT	496, 497, 498, 499, 501, 502
771 0552 30	FAG	PEUGEOT	472, 473, 474	814 0038 10	FAG	MERCEDES-BENZ	296
771 0561 30	FAG	RENAULT	545, 548, 551, 554, 556, 559	814 0038 10	FAG	VW	641, 642
771 0562 30	FAG	FORD	194, 196, 199	814 0039 10	FAG	MERCEDES-BENZ	296
771 0567 30	FAG	VW	615, 616, 618, 619, 627, 628, 629, 630, 631, 632, 633, 634, 635	814 0039 10	FAG	VW	641, 642
771 0568 30	FAG	FIAT	142, 143	814 0052 10	FAG	FORD	188, 189, 190, 191, 192, 193, 194
771 0573 30	FAG	CITROËN	136, 137	814 0076 10	FAG	VW	628, 629, 630, 631, 632, 633, 634, 635
771 0573 30	FAG	FIAT	166, 167, 168, 169	814 0085 10	FAG	RENAULT	495, 497, 499, 500, 502, 503
771 0573 30	FAG	PEUGEOT	470, 471	814 0092 10	FAG	RENAULT	495, 497, 499, 500, 502, 503
771 0578 30	FAG	VW	620, 621	814 0105 10	FAG	FIAT	145, 146, 147, 148, 149, 150, 151
771 0600 30	FAG	FORD	188, 189, 190, 191, 192, 193, 194	814 0106 10	FAG	FIAT	145, 146, 147, 148, 149, 150, 151
771 0603 30	FAG	FIAT	179, 180, 181	814 0125 10	FAG	FIAT	178, 179, 180, 181, 182
771 0603 30	FAG	PEUGEOT	476, 477, 478, 479	814 0125 10	FAG	PEUGEOT	475, 476, 477, 478, 479
772 0126 30	FAG	MERCEDES-BENZ	291, 292, 294, 295	814 0126 10	FAG	FIAT	178, 179, 180, 181, 182
772 0157 30	FAG	OPEL	411, 412, 413, 414	814 0126 10	FAG	PEUGEOT	475, 476, 477, 478, 479
772 0157 30	FAG	VAUXHALL	570, 571, 572				
772 0208 30	FAG	RENAULT	496, 498				
772 0229 30	FAG	RENAULT	496, 497, 498, 499, 501				
772 0230 30	FAG	RENAULT	508, 545, 548, 551, 552, 554, 556, 559				

*Unique LCV Application







**Numerische Liste / Numerical listing / Liste numérique / Listado numérico / Elenco numerico /
Listy numerycznej / Перечень артикулов**

SCHAEFFLER				SCHAEFFLER			
814 0127 10	FAG	CITROËN	128, 129, 130, 131, 132, 133, 134	818 0108 10	FAG	HYUNDAI	220, 221, 222
814 0127 10	FAG	FIAT	155, 156, 157, 158, 159, 160, 161, 162, 163, 164, 165	818 0109 10	FAG	HYUNDAI	220, 221, 222
814 0127 10	FAG	PEUGEOT	465, 466, 467, 468, 469	818 0142 10	FAG	FORD	214, 215, 216
814 0128 10	FAG	CITROËN	128, 129, 130, 131, 132, 133, 134	818 0143 10	FAG	FORD	214, 215, 216
814 0128 10	FAG	FIAT	155, 156, 157, 158, 159, 160, 161, 162, 163, 164, 165	818 0152 10	FAG	FORD	189, 190, 191, 192, 193, 194, 195, 196, 197, 198, 199, 200, 201, 202, 203, 204, 205, 206, 207, 208, 209, 210
814 0128 10	FAG	PEUGEOT	465, 466, 467, 468, 469	818 0174 10	FAG	OPEL	411, 412, 413, 414, 415
814 0135 10	FAG	NISSAN	402, 403, 406, 407, 408, 409, 410	818 0174 10	FAG	VAUXHALL	570, 571, 572, 573, 574
814 0135 10	FAG	OPEL	450, 451, 453, 454	818 0177 10	FAG	MERCEDES- BENZ	291, 293, 294, 295
814 0135 10	FAG	RENAULT	543, 545, 547, 549, 551, 552, 554, 557, 558	818 0177 10	FAG	VW	641, 642
814 0135 10	FAG	VAUXHALL	598, 599, 600, 601, 602, 603, 604, 605, 606, 607, 608, 609, 610, 611, 613, 614	818 0182 10	FAG	MERCEDES- BENZ	291, 292, 294, 295
814 0154 10	FAG	VW	665	818 0182 10	FAG	VW	641, 642
814 0155 10	FAG	VW	665	818 0183 10	FAG	MERCEDES- BENZ	291, 292, 294, 295
814 0157 10	FAG	CITROËN	134, 135, 136, 137, 138, 139	818 0183 10	FAG	VW	641, 642
814 0157 10	FAG	FIAT	166, 167, 168, 169, 170, 171, 172, 173, 174, 175, 176	818 0185 10	FAG	MERCEDES- BENZ	291, 292, 294, 295, 296
814 0157 10	FAG	PEUGEOT	469, 470, 471, 472, 473, 474	818 0186 10	FAG	MERCEDES- BENZ	291, 292, 294, 295, 296
814 0158 10	FAG	CITROËN	134, 135, 136, 137, 138, 139	818 0194 10	FAG	VW	615, 616, 617, 618, 619, 620, 621, 622, 623, 624, 625, 626, 627, 628, 629, 630, 631, 632, 633, 634, 635
814 0158 10	FAG	FIAT	166, 167, 168, 169, 170, 171, 172, 173, 174, 175, 176	818 0199 10	FAG	VW	643, 644, 645, 646, 647, 648, 649, 650, 651, 652, 653, 654, 655, 656, 657, 658, 659, 660, 661, 662, 663, 664, 665, 666, 667, 668, 669, 670, 671, 672, 673, 674, 675, 676, 677
814 0158 10	FAG	PEUGEOT	469, 470, 471, 472, 473, 474	818 0205 10	FAG	NISSAN	377, 378, 379, 380, 381, 382, 383, 384, 385, 386
814 0162 10	FAG	FORD	194, 195, 196, 197, 198, 199, 200, 201, 202, 203, 204, 205, 206, 207, 208, 209, 210, 215	818 0205 10	FAG	OPEL	418, 419, 420, 421, 422, 423, 424, 425, 426, 427, 429, 430, 431, 432
814 0178 10	FAG	MERCEDES- BENZ	357, 358, 359, 360, 361, 362, 363, 364, 365, 366, 367, 368, 369, 370, 371, 372, 373, 374, 375	818 0205 10	FAG	RENAULT	508, 509, 510, 511, 512, 513, 514, 515, 516, 517, 518, 519, 520, 521, 522, 523, 524, 525, 526
814 0182 10	FAG	RENAULT	503, 504, 505, 506, 507, 508	818 0205 10	FAG	VAUXHALL	577, 578, 579, 580, 581, 582, 583, 584, 585, 586, 587, 588
814 0187 10	FAG	VW	647, 665, 667, 668, 669, 670, 671, 672, 673, 674, 675, 676, 677	818 0206 10	FAG	NISSAN	377, 378, 379, 380, 381, 382, 383, 384, 385, 386
814 0188 10	FAG	VW	647, 665, 667, 668, 669, 670, 671, 672, 673, 674, 675, 676, 677	818 0206 10	FAG	OPEL	418, 419, 420, 421, 422, 423, 424, 425, 426, 427, 429, 430, 431, 432
815 0004 30	FAG	CITROËN	114, 115, 116, 118, 125	818 0206 10	FAG	RENAULT	508, 509, 510, 511, 512, 513, 514, 515, 516, 517, 518, 519, 520, 521, 522, 523, 524, 525, 526
815 0004 30	FAG	PEUGEOT	482, 483, 485, 493, 494	818 0206 10	FAG	VAUXHALL	577, 578, 579, 580, 581, 582, 583, 584, 585, 586, 587, 588
815 0005 30	FAG	CITROËN	114, 115, 116, 118, 125	818 0207 10	FAG	FIAT	183
815 0005 30	FAG	PEUGEOT	482, 483, 485, 493, 494	818 0207 10	FAG	NISSAN	388, 389, 402, 403, 404, 405, 406, 407, 408, 409, 410
815 0021 30	FAG	FORD	214, 215, 216	818 0207 10	FAG	OPEL	444, 445, 446, 447, 448, 449, 450, 451, 452, 453, 454, 455, 456, 457, 458, 459, 460, 461, 462, 463
815 0028 30	FAG	OPEL	411, 412, 413, 414	818 0207 10	FAG	RENAULT	543, 544, 545, 546, 547, 548, 549, 550, 551, 552, 553, 554, 555, 556, 557, 558, 559, 560, 561, 562, 563
815 0028 30	FAG	VAUXHALL	570, 571, 572, 573, 574	818 0207 10	FAG	VAUXHALL	598, 599, 600, 601, 602, 603, 604, 605, 606, 607, 608, 609, 610, 611, 612, 613, 614, 615
815 0040 30	FAG	VW	615, 616, 617, 618, 619, 620, 621, 622, 623, 624, 625, 626, 627, 628	818 0208 10	FAG	RENAULT	503, 504, 505, 506, 507, 508
815 0045 30	FAG	RENAULT	496, 498, 499, 501, 502	818 0226 10	FAG	CITROËN	128, 129, 130, 131, 132, 133, 134
815 0058 30	FAG	CITROËN	128	818 0226 10	FAG	FIAT	152, 153, 154, 155, 156, 157, 158, 159, 160, 161, 162, 163, 164, 165
815 0058 30	FAG	FIAT	153, 154	818 0226 10	FAG	PEUGEOT	464, 465, 466, 467, 468, 469
815 0058 30	FAG	PEUGEOT	464	818 0230 10	FAG	FIAT	176, 177, 178
815 0059 30	FAG	CITROËN	128				
815 0059 30	FAG	FIAT	153, 154				
815 0059 30	FAG	PEUGEOT	464				
815 0063 30	FAG	MERCEDES- BENZ	291, 292, 294, 295				
815 0068 30	FAG	NISSAN	404, 405, 406, 407, 409				
815 0068 30	FAG	OPEL	444, 445, 446, 447, 448, 449, 451, 452, 454, 455, 456, 457, 458, 459, 460				
815 0068 30	FAG	RENAULT	544, 545, 546, 548, 549, 550, 551, 552, 553, 554, 555, 556, 557, 559				
815 0071 30	FAG	CITROËN	114, 117, 118, 119, 120, 121, 122, 123, 124, 125, 126, 127				
815 0078 30	FAG	VW	643, 644, 645, 646, 647, 648, 649, 650, 651, 652, 653, 654, 655, 656, 657, 658, 659, 660, 661, 662, 663, 664, 665, 666				
818 0011 10	FAG	FIAT	178, 179, 180, 181				
818 0011 10	FAG	PEUGEOT	475, 476, 477, 478, 479				
818 0012 10	FAG	CITROËN	134, 135, 136, 137, 138, 139				
818 0012 10	FAG	FIAT	166, 167, 168, 169, 170, 171, 172, 173, 174, 175, 176				
818 0012 10	FAG	PEUGEOT	469, 470, 471, 472, 473, 474				

*Unique LCV Application





**Numerische Liste / Numerical listing / Liste numérique / Listado numérico / Elenco numerico /
Listy numerycznej / Перечень артикулов**

SCHAEFFLER				SCHAEFFLER			
818 0233 10	FAG	FIAT	182	818 0475 10	FAG	NISSAN	390, 391, 392, 393, 394, 395,
818 0233 10	FAG	PEUGEOT	479				396, 397, 398, 399, 400, 401
818 0243 10	FAG	CITROËN	114, 117, 118, 119, 120, 121,	818 0475 10	FAG	OPEL	433, 434, 435, 436, 437, 438,
			122, 123, 124, 125, 126, 127				439, 440, 441, 442, 443
818 0243 10	FAG	PEUGEOT	481, 484, 485, 486, 487, 488,	818 0475 10	FAG	RENAULT	526, 527, 528, 529, 530, 531,
			489, 490, 491, 492, 493				532, 533, 534, 535, 536, 537,
818 0278 10	FAG	CITROËN	114, 115, 116, 118, 125	818 0475 10	FAG	VAUXHALL	589, 590, 591, 592, 593, 594,
818 0278 10	FAG	FIAT	139, 140, 141, 142, 143, 144				595, 596, 597
818 0278 10	FAG	OPEL	415, 416, 417, 418	818 0479 10	FAG	CITROËN	134, 135, 136, 137, 138, 139
818 0278 10	FAG	PEUGEOT	482, 483, 486, 493, 494	818 0479 10	FAG	FIAT	166, 167, 168, 169, 170, 171,
818 0278 10	FAG	VAUXHALL	574, 575, 576				172, 173, 174, 175, 176
818 0292 10	FAG	FIAT	145, 146, 147, 148, 149, 150, 151	818 0479 10	FAG	PEUGEOT	469, 470, 471, 472, 473, 474
818 0304 10	FAG	FORD	189, 190, 191, 192, 193, 194	818 0480 10	FAG	CITROËN	134, 135, 136, 137, 138, 139
818 0306 10	FAG	MERCEDES- BENZ	357, 358, 359, 360, 361, 362,	818 0480 10	FAG	FIAT	166, 167, 168, 169, 170, 171,
			363, 364, 365, 366, 367, 368,				172, 173, 174, 175, 176
			369, 370, 371, 372, 373	818 0480 10	FAG	PEUGEOT	469, 470, 471, 472, 473, 474
818 0307 10	FAG	MERCEDES- BENZ	357, 358, 359, 360, 361, 362,	818 0482 10	FAG	NISSAN	390, 391, 392, 393, 394, 395,
			363, 364, 365, 366, 367, 368,				396, 397, 398, 399, 400, 401
			369, 370, 371, 372, 373	818 0482 10	FAG	OPEL	433, 434, 435, 436, 437, 438,
818 0313 10	FAG	RENAULT	501, 502, 503				439, 440, 441, 442, 443
818 0316 10	FAG	VW	615, 616, 617, 618, 619, 620,	818 0482 10	FAG	RENAULT	526, 527, 528, 529, 530, 531,
			621, 622, 624, 625, 626, 627				532, 533, 534, 535, 536, 537,
818 0317 10	FAG	FORD	184, 185, 186				538, 539, 540, 541, 542
818 0318 10	FAG	FORD	187, 188, 189, 190, 191, 192,	818 0482 10	FAG	VAUXHALL	589, 590, 591, 592, 593, 594,
			193, 194, 195, 196, 197, 198,				595, 596, 597
			199, 200, 202, 203, 204, 205,	818 0483 10	FAG	IVECO	222, 223, 224, 225, 226, 227,
			206, 207, 208, 209, 210, 211,				228, 229, 230, 231, 232, 233,
			212, 213				234, 235, 236, 237, 238, 239,
818 0335 10	FAG	MERCEDES- BENZ	295, 296, 297, 298, 299, 300,				240, 241, 242, 243, 244, 245,
			301, 302, 303, 304, 305, 306,	818 0484 10	FAG	IVECO	223, 224, 225, 226, 227, 228,
			307, 308, 309, 310, 311, 312,				229, 230, 231, 232, 233, 234,
			313, 314, 315, 317, 318, 319,				235, 236, 237, 238, 239, 240,
			320, 321, 322, 323, 324, 325,				241, 242, 243, 244, 245, 246,
			327, 328, 329, 331, 332, 334,				247, 248, 249, 250, 251, 252,
			335, 336, 337, 338, 339, 340,				253, 254, 255, 256, 257, 258,
			341, 342, 343, 344, 346, 347,				259, 260, 261, 262, 263, 264,
			348, 349, 350, 351, 352, 353,				265, 266, 267, 268, 269, 270,
			354, 355, 356, 357				271, 272, 273, 274, 275, 276
818 0335 10	FAG	VW	636, 637, 638, 639, 640, 641	818 0490 10	FAG	NISSAN	386, 387, 388
818 0336 10	FAG	MERCEDES- BENZ	295, 296, 297, 298, 299, 300,	818 0492 10	FAG	NISSAN	393, 394, 395, 396, 397, 398,
			301, 302, 303, 304, 305, 306,				399, 400
			307, 308, 309, 310, 311, 312,	818 0492 10	FAG	OPEL	433, 434, 435, 436, 441, 442, 443
			313, 314, 315, 317, 318, 319,	818 0492 10	FAG	RENAULT	527, 531, 532, 533, 535, 537,
			320, 321, 322, 323, 324, 325,				540, 541
			327, 328, 329, 331, 332, 334,	818 0492 10	FAG	VAUXHALL	589, 590, 592, 593, 594, 595, 596
			335, 336, 337, 338, 339, 340,	821 0102 10	FAG	HYUNDAI	220
			341, 342, 343, 344, 346, 347,	821 0103 10	FAG	HYUNDAI	220
			348, 349, 350, 351, 352, 353,	821 0263 10	FAG	FORD	188, 189, 190, 191, 192, 193,
			354, 355, 356, 357				194, 195, 196, 197, 198, 199,
818 0336 10	FAG	VW	636, 637, 638, 639, 640, 641				200, 201, 202, 203, 204, 205,
818 0345 10	FAG	FIAT	145, 146, 147, 148, 149, 150, 151				206, 207, 208, 209, 210
818 0375 10	FAG	FIAT	178, 179, 180, 181	821 0266 10	FAG	FORD	214, 216
818 0375 10	FAG	PEUGEOT	475, 476, 477, 478, 479	821 0267 10	FAG	FORD	214, 216
818 0395 10	FAG	TOYOTA	564, 565, 566, 567, 568	821 0291 10	FAG	OPEL	410, 411, 412, 413, 414
818 0396 10	FAG	TOYOTA	564, 565, 566, 567, 568	821 0291 10	FAG	VAUXHALL	569, 570, 571, 572, 573, 574
818 0412 10	FAG	TOYOTA	564, 565, 566, 567, 568	821 0291 10	FAG	OPEL	410, 411, 412, 413, 414
818 0413 10	FAG	TOYOTA	564, 565, 566, 567, 568	821 0292 10	FAG	VAUXHALL	569, 570, 571, 572, 573, 574
818 0447 10	FAG	MERCEDES- BENZ	297, 298, 299, 300, 301, 302,	821 0322 10	FAG	RENAULT	496, 497, 498, 499, 500, 501, 502
			303, 304, 305, 306, 307, 308,	821 0323 10	FAG	RENAULT	496, 497, 498, 499, 500, 501, 502
			309, 310, 311, 312, 313, 314,	821 0376 10	FAG	FIAT	145, 148, 149, 150
			315, 317, 318, 319, 320, 321,	821 0377 10	FAG	FIAT	144, 145, 148, 149, 150
			322, 323, 324, 325, 326, 327,	821 0408 10	FAG	PEUGEOT	479
			328, 329, 331, 332, 334, 335,	821 0409 10	FAG	PEUGEOT	479
			336, 337, 338, 339, 340, 341,	821 0424 10	FAG	FIAT	182
			342, 343, 344, 345, 346, 348,				
			349, 350, 352, 353, 354, 355,				
			356, 357				
818 0447 10	FAG	VW	636, 637, 638, 639, 640, 641				
818 0454 10	FAG	FORD	186, 187				
818 0473 10	FAG	CITROËN	134, 136, 137, 138, 139				
818 0473 10	FAG	FIAT	166, 167, 168, 169, 170, 171,				
			172, 173, 174, 175, 176				
818 0473 10	FAG	PEUGEOT	469, 470, 471, 472, 473, 474				
818 0474 10	FAG	NISSAN	386				

*Unique LCV Application







Numerische Liste / Numerical listing / Liste numérique / Listado numérico / Elenco numerico / Listy numerycznej / Перечень артикулов

SCHAEFFLER				SCHAEFFLER			
821 0424 10	FAG	PEUGEOT	479	821 0527 10	FAG	IVECO	237, 238, 239, 240, 241, 242,
821 0425 10	FAG	FIAT	182				243, 244, 245, 246, 247, 248,
821 0425 10	FAG	PEUGEOT	479				249, 250, 251, 252, 253, 254,
821 0428 10	FAG	CITROËN	114, 116, 117, 118, 119, 120,				255, 256, 257, 258, 259, 260,
			121, 122, 123, 124, 125, 126, 127				261, 262, 263, 264, 265, 266,
821 0428 10	FAG	PEUGEOT	481, 484, 485, 486, 487, 488,				267, 268, 269, 270, 271, 272,
			489, 490, 491, 492, 493				273, 274, 275
821 0429 10	FAG	CITROËN	114, 116, 117, 118, 119, 120,	821 0557 10	FAG	NISSAN	377, 378, 379, 380, 381, 382,
			121, 122, 123, 124, 125, 126, 127				383, 384, 385
821 0429 10	FAG	PEUGEOT	481, 484, 485, 486, 487, 488,	821 0557 10	FAG	OPEL	418, 419, 420, 421, 422, 424,
			489, 490, 491, 492, 493				425, 426, 427, 428, 429, 430,
							431, 432
821 0464 10	FAG	CITROËN	114, 115, 125	821 0557 10	FAG	RENAULT	508, 509, 510, 511, 512, 513,
821 0464 10	FAG	PEUGEOT	482, 493				514, 515, 516, 517, 518, 519,
821 0465 10	FAG	CITROËN	114, 115, 125				520, 521, 523, 524, 525
821 0465 10	FAG	PEUGEOT	482, 493	821 0557 10	FAG	VAUXHALL	576, 577, 578, 579
821 0466 10	FAG	CITROËN	114, 115	821 0558 10	FAG	NISSAN	377, 378, 379, 380, 381, 382,
821 0466 10	FAG	PEUGEOT	482, 493				383, 384, 385
821 0467 10	FAG	CITROËN	116, 118	821 0558 10	FAG	OPEL	418, 419, 420, 421, 422, 424,
821 0467 10	FAG	PEUGEOT	483, 485, 494				425, 426, 427, 428, 429, 430,
821 0468 10	FAG	CITROËN	116, 118				431, 432
821 0468 10	FAG	PEUGEOT	483, 485, 494	821 0558 10	FAG	RENAULT	508, 509, 510, 511, 512, 513,
821 0469 10	FAG	CITROËN	114, 115, 125				514, 515, 516, 517, 518, 519,
821 0469 10	FAG	PEUGEOT	482, 493				520, 521, 522, 523, 524, 525
821 0470 10	FAG	CITROËN	114, 115, 125	821 0558 10	FAG	VAUXHALL	576, 577, 578, 579
821 0470 10	FAG	PEUGEOT	482, 493	821 0559 10	FAG	FIAT	144, 145, 146, 147, 148, 149, 150
821 0489 10	FAG	NISSAN	402, 404, 405, 406, 407, 408, 409	821 0560 10	FAG	FIAT	145, 146, 147, 148, 149, 150
821 0489 10	FAG	OPEL	444, 445, 446, 447, 448, 449,	821 0563 10	FAG	VW	616, 617, 618, 620, 621, 622,
			450, 451, 452, 453, 454, 455,				624, 626
			456, 457, 458, 459, 460	821 0564 10	FAG	VW	616, 617, 618, 620, 621, 622,
821 0489 10	FAG	RENAULT	543, 544, 545, 546, 547, 548,				624, 626
			549, 550, 551, 552, 553, 554,	821 0571 10	FAG	MERCEDES- BENZ	357, 358, 359, 360, 361, 362,
			555, 556, 557, 558, 559				363, 364, 366, 367, 369, 370,
821 0489 10	FAG	VAUXHALL	598, 599, 600, 601, 602, 603,				372, 373
			604, 605, 606, 608, 609, 610,	821 0572 10	FAG	MERCEDES- BENZ	357, 358, 359, 360, 361, 362,
			611, 613				363, 364, 366, 367, 369, 370,
821 0490 10	FAG	NISSAN	402, 404, 405, 406, 407, 408, 409				372, 373
821 0490 10	FAG	OPEL	444, 445, 446, 447, 448, 449,	821 0574 10	FAG	FIAT	176, 177, 178
			450, 451, 452, 453, 454, 455,	821 0575 10	FAG	FIAT	176, 177, 178
			456, 457, 458, 459	821 0593 10	FAG	VW	641, 642
821 0490 10	FAG	RENAULT	543, 544, 545, 546, 547, 548,	821 0594 10	FAG	VW	641, 642
			549, 550, 551, 552, 553, 554,	821 0627 10	FAG	CITROËN	134, 135, 136, 137, 138
			555, 556, 557, 558, 559	821 0627 10	FAG	FIAT	165, 166, 167, 168, 169, 170,
821 0490 10	FAG	VAUXHALL	598, 599, 600, 601, 602, 603,				171, 172, 173, 175
			604, 605, 606, 608, 609, 610,	821 0627 10	FAG	PEUGEOT	469, 470, 471, 472, 473, 474
			611, 613	821 0628 10	FAG	CITROËN	134, 135, 136, 137, 138
821 0524 10	FAG	IVECO	222, 223, 224, 225, 226, 227,	821 0628 10	FAG	FIAT	165, 166, 167, 168, 169, 170,
			229, 230, 231, 234, 235, 236,				171, 172, 173, 175
			237, 238, 239, 240, 241, 242,	821 0628 10	FAG	PEUGEOT	469, 470, 471, 472, 473, 474
			243, 244, 245, 246, 247, 248,	821 0699 10	FAG	MERCEDES- BENZ	297, 298, 299, 300, 301, 302,
			249, 250, 251, 252, 253, 254,				303, 304, 305, 306, 307, 308,
			255, 256, 257, 258, 259, 260,				309, 310, 311, 312, 313, 314,
			261, 262, 263, 264, 265, 266,				315, 317, 318, 321, 322, 323,
			267, 268, 269, 270, 271, 272,				324, 328, 332, 334, 341, 342,
			273, 274, 275				343, 344, 345, 348, 350, 352,
821 0525 10	FAG	IVECO	222, 223, 224, 225, 226, 227,				353, 354, 355, 357
			228, 230, 231, 234, 235, 236,	821 0699 10	FAG	VW	636, 639, 640, 641
			237, 238, 239, 240, 241, 242,	821 0700 10	FAG	MERCEDES- BENZ	297, 298, 299, 300, 301, 302,
			243, 244, 245, 246, 247, 248,				303, 304, 305, 306, 307, 308,
			249, 250, 251, 252, 253, 254,				309, 310, 311, 312, 313, 314,
			255, 256, 257, 258, 259, 260,				315, 317, 318, 321, 322, 323,
			261, 262, 263, 264, 265, 266,				324, 328, 332, 334, 341, 342,
			267, 268, 269, 270, 271, 272,				343, 344, 345, 348, 350, 352,
			273, 274, 275				353, 354, 355, 357
821 0526 10	FAG	IVECO	222, 223, 224, 225, 226, 227,	821 0700 10	FAG	VW	636, 639, 640, 641
			229, 230, 231, 234, 235, 236,	821 0717 10	FAG	FIAT	178, 179, 180, 181
			237, 238, 239, 240, 241, 242,	821 0717 10	FAG	PEUGEOT	475, 476, 477, 478, 479
			243, 244, 245, 246, 247, 248,	821 0718 10	FAG	FIAT	178, 179, 180, 181
			249, 250, 251, 252, 253, 254,	821 0718 10	FAG	PEUGEOT	475, 476, 477, 478, 479
			255, 256, 257, 258, 259, 260,	821 0724 10	FAG	FIAT	145, 146, 147, 148, 149, 150, 151
			261, 262, 263, 264, 265, 266,	821 0725 10	FAG	FIAT	144, 145, 146, 147, 148, 149,
			267, 268, 269, 270, 271, 272,				150, 151
			273, 274, 275	821 0742 10	FAG	TOYOTA	564, 565, 568
821 0527 10	FAG	IVECO	222, 223, 224, 225, 226, 227,	821 0743 10	FAG	TOYOTA	564, 565, 568
			229, 230, 231, 234, 235, 236,				

*Unique LCV Application





**Numerische Liste / Numerical listing / Liste numérique / Listado numérico / Elenco numerico /
Listy numerycznej / Перечень артикулов**

SCHAEFFLER				SCHAEFFLER			
821 0767 10	FAG	VW	616, 617, 618, 620, 621, 622, 624, 626	821 0865 10	FAG	NISSAN	390, 391, 392, 393, 394, 395, 396, 397, 398, 399, 400, 401
821 0768 10	FAG	VW	616, 617, 618, 620, 621, 622, 624, 626	821 0865 10	FAG	OPEL	433, 434, 435, 436, 437, 438, 439, 440, 441, 442, 443
821 0809 10	FAG	CITROËN	127, 128, 129, 130, 131, 132, 133, 134	821 0865 10	FAG	RENAULT	526, 527, 528, 529, 530, 531, 532, 533, 534, 535, 536, 537, 538, 539, 540, 541, 542
821 0809 10	FAG	FIAT	152, 153, 154, 155, 156, 157, 158, 159, 160, 161, 162, 163, 164, 165	821 0865 10	FAG	VAUXHALL	589, 590, 591, 592, 593, 594, 595, 596, 597
821 0809 10	FAG	PEUGEOT	463, 464, 465, 466, 467, 468, 469	821 0868 10	FAG	NISSAN	390, 391, 392, 393, 394, 395, 396, 397, 398, 399, 400, 401
821 0810 10	FAG	CITROËN	127, 128, 129, 130, 131, 132, 133, 134	821 0868 10	FAG	OPEL	433, 434, 435, 436, 437, 438, 439, 440, 441, 442, 443
821 0810 10	FAG	FIAT	152, 153, 154, 155, 156, 157, 158, 159, 160, 161, 162, 163, 164, 165	821 0868 10	FAG	RENAULT	526, 527, 528, 529, 530, 531, 532, 533, 534, 535, 536, 537, 538, 539, 540, 541, 542
821 0810 10	FAG	PEUGEOT	463, 464, 465, 466, 467, 468, 469	821 0868 10	FAG	VAUXHALL	589, 590, 591, 592, 593, 594, 595, 596, 597
821 0811 10	FAG	VW	642, 643, 644, 645, 646, 647, 648, 649, 650, 651, 652, 653, 654, 655, 656, 657, 658, 659, 660, 661, 662, 663, 664, 665, 666	821 0893 10	FAG	FIAT	139, 140, 141, 142, 143, 144
821 0812 10	FAG	VW	642, 643, 644, 645, 646, 647, 648, 649, 650, 651, 652, 653, 654, 655, 656, 657, 658, 659, 660, 661, 662, 663, 664, 665, 666	821 0893 10	FAG	OPEL	415, 416, 417
821 0821 10	FAG	NISSAN	404, 405, 406, 407, 408, 409, 410	821 0893 10	FAG	VAUXHALL	574, 575, 576
821 0821 10	FAG	OPEL	444, 445, 446, 447, 448, 449, 450, 451, 452, 453, 454, 455, 456, 457, 458, 459, 460	821 0908 10	FAG	FIAT	139, 140, 141, 142, 143, 144
821 0821 10	FAG	RENAULT	543, 544, 545, 546, 547, 548, 550, 551, 552, 553, 555, 556, 557, 558, 559	821 0908 10	FAG	OPEL	415, 416, 417
821 0821 10	FAG	VAUXHALL	598, 599, 600, 601, 602, 603, 604, 605, 606, 607, 608, 609, 610, 611, 613	821 0908 10	FAG	VAUXHALL	574, 575, 576
821 0822 10	FAG	NISSAN	404, 405, 406, 407, 408, 409, 410	821 0952 10	FAG	RENAULT	503, 504, 505, 506, 507, 508
821 0822 10	FAG	OPEL	444, 445, 446, 447, 448, 449, 450, 451, 452, 453, 454, 455, 456, 457, 458, 459	821 0953 10	FAG	RENAULT	503, 504, 505, 506, 507, 508
821 0822 10	FAG	RENAULT	543, 544, 545, 546, 547, 548, 550, 551, 552, 553, 555, 556, 557, 558, 559	825 0011 10	FAG	TOYOTA	564, 565, 566, 567, 568
821 0822 10	FAG	VAUXHALL	598, 599, 600, 601, 602, 603, 604, 605, 606, 608, 609, 610, 611, 613	825 0085 10	FAG	HYUNDAI	220, 221, 222
821 0855 10	FAG	NISSAN	378, 379, 380, 381, 383, 384, 385	825 0104 10	FAG	FORD	187, 188, 189, 190, 191, 192, 193, 194, 195, 196, 197, 198, 199, 200, 201, 202, 203, 204, 205, 206, 207, 208, 209, 210, 211, 212, 213, 214, 215, 216
821 0855 10	FAG	OPEL	418, 419, 420, 421, 422, 423, 424, 425, 426, 427, 428, 429, 430, 432	825 0123 10	FAG	VW	641, 642
821 0855 10	FAG	RENAULT	508, 509, 510, 511, 512, 513, 514, 515, 516, 517, 518, 519, 520, 521, 523, 524, 525	825 0128 10	FAG	OPEL	411, 412, 413, 414, 415
821 0855 10	FAG	VAUXHALL	577, 579, 580, 581, 582, 583, 584, 585, 586, 587, 588	825 0128 10	FAG	VAUXHALL	570, 571, 572, 573, 574
821 0857 10	FAG	NISSAN	378, 379, 380, 381, 383, 384, 385	825 0166 10	FAG	NISSAN	377, 378, 379, 380, 382, 384, 385, 386
821 0857 10	FAG	OPEL	418, 419, 420, 421, 422, 423, 424, 425, 426, 427, 428, 429, 430, 431, 432	825 0166 10	FAG	OPEL	418, 419, 420, 421, 422, 423, 424, 425, 426, 427, 428, 429, 430, 431, 432
821 0857 10	FAG	RENAULT	508, 509, 510, 511, 512, 513, 514, 515, 516, 517, 518, 519, 520, 521, 522, 523, 524, 525	825 0166 10	FAG	RENAULT	508, 509, 510, 511, 512, 513, 514, 515, 516, 517, 518, 519, 520, 521, 522, 523, 524, 525, 526
821 0857 10	FAG	VAUXHALL	577, 579, 580, 581, 582, 583, 584, 585, 586, 587, 588	825 0166 10	FAG	VAUXHALL	577, 578, 579, 580, 581, 582, 583, 584, 585, 586, 587, 588
821 0858 10	FAG	CITROËN	127, 128, 129, 130, 131, 132, 133, 134	825 0184 10	FAG	FIAT	145, 146, 147, 148, 149, 150, 151
821 0858 10	FAG	FIAT	152, 153, 154, 155, 156, 157, 158, 159, 160, 161, 162, 163, 164, 165	825 0185 10	FAG	FIAT	145, 146, 147, 148, 149, 150, 151
821 0858 10	FAG	PEUGEOT	463, 464, 465, 466, 467, 468, 469	825 0192 10	FAG	CITROËN	114, 117, 119, 120, 121, 122, 123, 124, 125, 126, 127
821 0859 10	FAG	CITROËN	127, 128, 129, 130, 131, 132, 133, 134	825 0192 10	FAG	PEUGEOT	481, 484, 485, 486, 487, 488, 489, 490, 491, 492, 493
821 0859 10	FAG	FIAT	152, 153, 154, 155, 156, 157, 158, 159, 160, 161, 162, 163, 164, 165	825 0222 10	FAG	PEUGEOT	482, 483, 493
821 0859 10	FAG	PEUGEOT	463, 464, 465, 466, 467, 468, 469	825 0223 10	FAG	CITROËN	114, 115, 125
821 0859 10	FAG	PEUGEOT	463, 464, 465, 466, 467, 468, 469	825 0223 10	FAG	PEUGEOT	482, 483, 493
821 0859 10	FAG	PEUGEOT	463, 464, 465, 466, 467, 468, 469	825 0242 10	FAG	IVECO	223, 224, 225, 226, 227, 228, 229, 230, 231, 232, 233, 234, 235, 236, 237, 238, 239, 240, 241, 242, 243, 244, 245, 246, 247, 248, 249, 250, 251, 252, 253, 254, 255, 256, 257, 258, 259, 260, 261, 262, 263, 264, 265, 266, 267, 268, 269, 270, 271, 272, 273, 274, 275, 276

*Unique LCV Application







Numerische Liste / Numerical listing / Liste numérique / Listado numérico / Elenco numerico / Listy numerycznej / Перечень артикулов

SCHAEFFLER				SCHAEFFLER			
825 0243 10	FAG	IVECO	223, 224, 225, 226, 227, 228, 229, 230, 231, 232, 233, 234, 235, 236, 237, 238, 239, 240, 241, 242, 243, 244, 245, 246, 247, 248, 249, 250, 251, 252, 253, 254, 255, 256, 257, 258, 259, 260, 261, 262, 263, 264, 265, 266, 267, 268, 269, 270, 271, 272, 273, 274, 275, 276	825 0318 10	FAG	PEUGEOT	464, 465, 466, 467, 468, 469
825 0250 10	FAG	MERCEDES-BENZ	357, 358, 359, 360, 361, 362, 363, 364, 365, 366, 367, 368, 369, 370, 371, 372, 373	825 0319 10	FAG	CITROËN	128, 129, 130, 131, 132, 133, 134
825 0258 10	FAG	RENAULT	496, 497, 498, 499, 500, 501, 502, 503	825 0319 10	FAG	FIAT	152, 153, 154, 155, 156, 157, 158, 159, 160, 161, 162, 163, 164, 165
825 0259 10	FAG	RENAULT	496, 497, 498, 499, 500, 501, 502, 503	825 0319 10	FAG	PEUGEOT	464, 465, 466, 467, 468, 469
825 0260 10	FAG	NISSAN	402, 403, 404, 405, 406, 407, 408, 409	825 0327 10	FAG	MERCEDES-BENZ	297, 298, 299, 300, 301, 302, 303, 304, 305, 306, 307, 308, 309, 310, 311, 312, 313, 314, 315, 316, 317, 318, 319, 320, 321, 322, 323, 324, 325, 326, 327, 328, 329, 330, 331, 332, 333, 334, 335, 336, 337, 338, 339, 340, 341, 342, 343, 344, 345, 346, 347, 348, 349, 350, 351, 352, 353, 354, 355, 356, 357
825 0260 10	FAG	OPEL	444, 445, 446, 447, 448, 449, 451, 452, 453, 454, 455, 456, 457, 458, 459, 460	825 0327 10	FAG	VW	636, 637, 638, 639, 640, 641
825 0260 10	FAG	RENAULT	543, 544, 545, 546, 547, 548, 549, 550, 551, 552, 553, 554, 555, 556, 557, 558, 559	825 0331 10	FAG	NISSAN	390, 391, 392, 393, 394, 395, 396, 397, 398, 399, 400, 401
825 0260 10	FAG	VAUXHALL	598, 599, 600, 601, 602, 603, 604, 605, 606, 607, 608, 610, 613, 614	825 0332 10	FAG	OPEL	433, 434, 435, 436, 437, 438, 439, 440, 441, 442, 443
825 0261 10	FAG	NISSAN	404, 405, 406, 407, 408, 409, 410	825 0332 10	FAG	RENAULT	526, 527, 528, 529, 530, 531, 532, 534, 535, 536, 537, 538, 539, 540, 541, 542
825 0261 10	FAG	OPEL	444, 445, 446, 447, 448, 449, 450, 451, 452, 453, 454, 455, 456, 457, 458, 459, 460	825 0332 10	FAG	VAUXHALL	589, 590, 591, 592, 593, 594, 595, 596, 597
825 0261 10	FAG	RENAULT	544, 545, 546, 547, 548, 549, 550, 551, 552, 553, 554, 555, 556, 557, 558, 559	825 0333 10	FAG	NISSAN	390, 391, 392, 393, 394, 395, 396, 397, 398, 399, 400, 401
825 0261 10	FAG	VAUXHALL	599, 600, 602, 603, 605, 606, 608, 609, 610, 611, 614	825 0333 10	FAG	OPEL	433, 434, 435, 436, 437, 438, 439, 440, 441, 442, 443
825 0266 10	FAG	VW	643, 644, 645, 646, 647, 648, 649, 650, 651, 652, 653, 654, 655, 656, 657, 658, 659, 660, 661, 662, 663, 664, 665, 666, 667, 668, 669, 670, 671, 672, 673, 674, 675, 676, 677	825 0333 10	FAG	RENAULT	526, 527, 528, 529, 530, 531, 532, 534, 535, 536, 537, 538, 539, 540, 541, 542
825 0273 10	FAG	FORD	194, 195, 196, 197, 198, 199, 200, 201, 202, 203, 204, 205, 206, 207, 208, 209, 210	825 0333 10	FAG	VAUXHALL	589, 590, 591, 592, 593, 594, 595, 596, 597
825 0274 10	FAG	FIAT	176, 177, 178	825 0339 10	FAG	RENAULT	503, 504, 505, 506, 507, 508
825 0277 10	FAG	CITROËN	135, 136, 137, 138, 139	825 0341 10	FAG	RENAULT	503, 504, 505, 506, 507, 508
825 0277 10	FAG	FIAT	166, 167, 168, 169, 170, 171, 172, 173, 174, 175, 176	825 0361 10	FAG	VW	615, 616, 617, 618, 619, 620, 621, 622, 623, 624, 625, 626, 627, 628, 629, 630, 631, 632, 633, 634, 635
825 0277 10	FAG	PEUGEOT	469, 470, 471, 472, 473, 474	825 0362 10	FAG	VW	615, 616, 617, 618, 619, 620, 621, 622, 623, 624, 625, 626, 627, 628, 629, 630, 631, 632, 633, 634, 635
825 0280 10	FAG	NISSAN	377, 378, 379, 380, 381, 382, 383, 384, 385, 386	825 0371 10	FAG	VW	628, 629, 630, 631, 632, 633, 634, 635
825 0280 10	FAG	OPEL	418, 419, 420, 421, 422, 423, 424, 425, 426, 427, 428, 429, 430, 431, 432	825 0372 10	FAG	VW	628, 629, 630, 631, 632, 633, 634, 635
825 0280 10	FAG	RENAULT	508, 509, 510, 511, 512, 513, 514, 515, 516, 517, 518, 519, 520, 521, 522, 523, 524, 525, 526	825 0380 10	FAG	FIAT	139, 140, 141, 142, 143, 144
825 0280 10	FAG	VAUXHALL	577, 578, 579, 580, 581, 582, 583, 584, 585, 586, 587, 588	825 0380 10	FAG	OPEL	415, 416, 417, 418
825 0300 10	FAG	NISSAN	378, 379, 380, 381, 382, 383, 384, 385, 386	825 0380 10	FAG	VAUXHALL	574, 575, 576
825 0300 10	FAG	OPEL	418, 419, 420, 421, 422, 423, 424, 425, 426, 427, 428, 429, 430, 431, 432	830 0019 30	FAG	RENAULT	496, 497, 498, 499, 500, 501, 502, 503
825 0300 10	FAG	RENAULT	508, 509, 510, 511, 512, 513, 514, 515, 516, 517, 518, 519, 520, 521, 522, 523, 524, 525, 526	830 0038 30	FAG	CITROËN	114, 115, 116, 118, 125
825 0300 10	FAG	VAUXHALL	577, 579, 580, 581, 582, 583, 584, 585, 586, 587, 588	830 0038 30	FAG	PEUGEOT	482, 483, 486, 493, 494
825 0318 10	FAG	CITROËN	128, 129, 130, 131, 132, 133, 134	830 0039 30	FAG	CITROËN	114, 115, 116, 118, 125
825 0318 10	FAG	FIAT	152, 153, 154, 155, 156, 157, 158, 159, 160, 161, 162, 163, 164, 165	830 0039 30	FAG	PEUGEOT	482, 483, 486, 493, 494
				830 0042 30	FAG	CITROËN	114, 115, 116, 118, 125
				830 0042 30	FAG	PEUGEOT	482, 483, 486, 493, 494
				830 0051 30	FAG	CITROËN	114, 115, 116, 118, 125
				830 0051 30	FAG	PEUGEOT	482, 483, 486, 493, 494
				840 0046 10	FAG	IVECO	223, 224, 225, 226, 227, 228, 229, 230, 231, 232, 233, 234, 235, 236, 237, 238, 239, 240, 241, 242, 243, 244, 245, 246, 247, 248, 249, 250, 251, 252, 253, 254, 255, 256, 257, 258, 259, 260, 261, 262, 263, 264, 265, 266, 267, 268, 269, 270, 271, 272, 273, 274, 275, 276, 277, 278, 279, 280, 281
				840 0052 10	FAG	NISSAN	376

*Unique LCV Application





**Numerische Liste / Numerical listing / Liste numérique / Listado numérico / Elenco numerico /
Listy numerycznej / Перечень артикулов**

SCHAEFFLER				SCHAEFFLER			
840 0099 10	FAG	HYUNDAI	221, 222	840 0313 10	FAG	MERCEDES-BENZ	358, 359, 360, 361, 362, 363, 364, 365, 366, 367, 368, 369, 370, 371, 372, 373
840 0099 10	FAG	MITSUBISHI	376	840 0321 10	FAG	CITROËN	114, 117, 118, 119, 120, 121, 122, 123, 124, 125, 126, 127
840 0130 10	FAG	FORD	214, 215, 216	840 0321 10	FAG	PEUGEOT	481, 484, 485, 486, 487, 488, 489, 490, 491, 492, 493
840 0134 10	FAG	FORD	189, 190, 191, 192, 193, 194, 195, 196, 197, 198, 199, 200, 201, 202, 203, 204, 205, 206, 207, 208, 209, 210	840 0332 10	FAG	FIAT	178, 179, 180, 181
840 0151 10	FAG	MERCEDES-BENZ	291, 293, 294, 295	840 0332 10	FAG	PEUGEOT	475, 476, 477, 478, 479
840 0151 10	FAG	VW	641, 642	840 0340 10	FAG	TOYOTA	564, 565, 566, 567, 568, 569
840 0156 10	FAG	OPEL	411, 412, 413, 414, 415	840 0350 10	FAG	RENAULT	495, 496, 497, 498, 499, 500, 501, 502
840 0156 10	FAG	VAUXHALL	570, 571, 572, 573, 574	840 0373 10	FAG	MERCEDES-BENZ	295, 296, 297, 298, 299, 300, 301, 302, 303, 304, 305, 306, 307, 308, 309, 310, 311, 312, 313, 314, 315, 316, 317, 318, 319, 320, 321, 322, 323, 324, 325, 326, 327, 328, 329, 330, 331, 332, 333, 334, 335, 336, 337, 338, 339, 340, 341, 342, 343, 344, 345, 346, 347, 348, 349, 350, 351, 352, 353, 354, 355, 356, 357
840 0169 10	FAG	VW	615, 616, 617, 618, 619, 620, 621, 622, 623, 624, 625, 626, 627, 628, 629, 630, 631, 632, 633, 634, 635	840 0373 10	FAG	VW	636, 637, 638, 639, 640, 641
840 0177 10	FAG	VW	643, 644, 645, 646, 647, 648, 649, 650, 651, 652, 653, 654, 655, 656, 657, 658, 659, 660, 661, 662, 663, 664, 665, 666, 667, 668, 669, 670, 671, 672, 673, 674, 675, 676, 677	840 0375 10	FAG	RENAULT	503, 504, 505, 506, 507, 508
840 0198 10	FAG	NISSAN	377, 378, 379, 380, 381, 382, 383, 384, 385, 386	840 0376 10	FAG	FORD	184, 185, 186
840 0198 10	FAG	OPEL	418, 419, 420, 421, 422, 423, 424, 425, 426, 427, 428, 429, 430, 431, 432	840 0384 10	FAG	OPEL	411
840 0198 10	FAG	RENAULT	508, 509, 510, 511, 512, 513, 514, 515, 516, 517, 518, 519, 520, 521, 522, 523, 524, 525, 526	840 0384 10	FAG	VAUXHALL	570
840 0198 10	FAG	VAUXHALL	577, 578, 579, 580, 581, 582, 583, 584, 585, 586, 587, 588	840 0388 10	FAG	CITROËN	135, 136, 137, 138, 139
840 0201 10	FAG	RENAULT	495, 496, 497, 498, 499, 500, 501, 502	840 0388 10	FAG	FIAT	166, 167, 168, 169, 170, 171, 172, 173, 175, 176
840 0209 10	FAG	FIAT	182	840 0388 10	FAG	PEUGEOT	469, 470, 471, 472, 473, 474
840 0209 10	FAG	PEUGEOT	479	840 0394 10	FAG	NISSAN	390, 391, 392, 393, 394, 395, 396, 397, 398, 399, 400, 401
840 0223 10	FAG	FIAT	145, 146, 147, 148, 149, 150, 151	840 0394 10	FAG	OPEL	433, 434, 435, 436, 437, 438, 439, 440, 441, 442, 443, 444
840 0229 10	FAG	FIAT	145, 146, 147, 148, 149, 150, 151	840 0394 10	FAG	RENAULT	526, 527, 528, 529, 530, 531, 532, 533, 534, 535, 536, 537, 538, 539, 540, 541, 542
840 0238 10	FAG	CITROËN	128, 129, 130, 131, 132, 133, 134	840 0394 10	FAG	VAUXHALL	589, 590, 591, 592, 593, 594, 595, 596, 597
840 0238 10	FAG	FIAT	152, 153, 154, 155, 156, 158, 159, 160, 162, 163, 164, 165	840 0395 10	FAG	FIAT	176, 177, 178
840 0238 10	FAG	PEUGEOT	464, 465, 466, 467, 468, 469	840 0404 10	FAG	FIAT	139, 140, 141, 142, 143, 144
840 0264 10	FAG	CITROËN	114, 115, 125	840 0404 10	FAG	OPEL	415, 416, 417, 418
840 0264 10	FAG	PEUGEOT	482, 483, 493	840 0404 10	FAG	VAUXHALL	574, 575, 576
840 0265 10	FAG	CITROËN	116, 118	840 0404 10	FAG	RENAULT	501, 502, 503
840 0265 10	FAG	PEUGEOT	483, 486, 494	840 0415 10	FAG	OPEL	411, 412, 413, 414, 415
840 0274 10	FAG	FIAT	183	840 0415 10	FAG	VAUXHALL	570, 571, 572, 573, 574
840 0274 10	FAG	NISSAN	388, 389, 402, 403, 404, 405, 406, 407, 408, 409, 410	840 0524 10	FAG	VW	643, 644, 645, 647, 653, 654, 655, 656, 657, 659, 664, 665, 666
840 0274 10	FAG	OPEL	444, 445, 446, 447, 448, 449, 450, 451, 452, 453, 454, 455, 456, 457, 458, 459, 460, 461, 462, 463	840 0526 10	FAG	VW	643, 644, 645, 647, 653, 654, 655, 656, 657, 659, 664, 665, 666
840 0274 10	FAG	RENAULT	543, 544, 545, 546, 547, 548, 549, 550, 551, 552, 553, 554, 555, 556, 557, 558, 559, 560, 561, 562, 563	840 0622 10	FAG	IVECO	223, 224, 225, 226, 227, 228, 229, 230, 231, 232, 233, 234, 235, 236, 237, 238, 239, 240, 241, 242, 243, 244, 245, 246, 247, 248, 249, 250, 251, 252, 253, 254, 255, 256, 257, 258, 259, 260, 261, 262, 263, 264, 265, 266, 267, 268, 269, 270, 271, 272, 273, 274, 275, 276, 277, 278, 279, 280, 281
840 0274 10	FAG	VAUXHALL	598, 599, 600, 601, 602, 603, 604, 605, 606, 607, 608, 609, 610, 611, 612, 613, 614, 615	840 0637 10	FAG	HYUNDAI	220, 221, 222
840 0284 10	FAG	FORD	189, 190, 191, 192, 193, 194, 195, 196, 197, 198, 199, 200, 201, 202, 203, 204, 205, 206, 207, 208, 209, 210	840 0637 10	FAG	MITSUBISHI	376
840 0285 10	FAG	CITROËN	128, 129, 130, 131, 132, 133, 134	840 0775 10	FAG	FORD	188, 189, 190, 191, 192, 193, 194, 195, 196, 197, 198, 199, 200, 201, 202, 203, 204, 205, 206, 207, 208, 209, 210, 211, 212, 213, 214
840 0285 10	FAG	FIAT	152, 153, 154, 155, 156, 157, 158, 159, 160, 161, 162, 163, 164, 165	840 0778 10	FAG	FORD	214, 215, 216
840 0285 10	FAG	PEUGEOT	464, 465, 466, 467, 468, 469	840 0785 10	FAG	OPEL	411, 412, 413, 414, 415
840 0286 10	FAG	CITROËN	128, 129, 130, 131, 132, 133, 134	840 0785 10	FAG	VAUXHALL	570, 571, 572, 573, 574
840 0286 10	FAG	FIAT	152, 153, 154, 155, 156, 157, 158, 159, 160, 161, 162, 163, 164, 165				
840 0286 10	FAG	PEUGEOT	464, 465, 466, 467, 468, 469				

*Unique LCV Application







**Numerische Liste / Numerical listing / Liste numérique / Listado numérico / Elenco numerico /
Listy numerycznej / Перечень артикулов**

SCHAEFFLER				SCHAEFFLER			
840 0842 10	FAG	VW	643, 644, 645, 646, 647, 648, 649, 650, 651, 652, 653, 654, 655, 656, 657, 658, 659, 660, 661, 662, 663, 664, 665, 666, 667, 668, 669, 670, 671, 672, 673, 674, 675, 676, 677	840 0999 10	FAG	CITROËN	128, 129, 130, 131, 132, 133, 134
840 0843 10	FAG	VW	643, 644, 645, 646, 647, 648, 649, 650, 651, 652, 653, 654, 655, 656, 657, 658, 659, 660, 661, 662, 663, 664, 665, 666, 667, 668, 669, 670, 671, 672, 673, 674, 675, 676, 677	840 0999 10	FAG	FIAT	155, 156, 157, 158, 159, 160, 161, 162, 163, 164, 165
840 0875 10	FAG	RENAULT	495, 496, 497, 498, 499, 500, 501, 502, 503	840 0999 10	FAG	PEUGEOT	465, 466, 467, 468, 469
840 0876 10	FAG	RENAULT	495, 496, 497, 498, 499, 500, 501, 502, 503	840 1003 10	FAG	FIAT	182
840 0877 10	FAG	NISSAN	377, 378, 379, 380, 381, 382, 383, 384, 385, 386	840 1003 10	FAG	PEUGEOT	479
840 0877 10	FAG	OPEL	418, 419, 420, 421, 422, 423, 424, 425, 426, 427, 428, 429, 430, 431, 432	840 1015 10	FAG	MERCEDES- BENZ	358, 359, 360, 361, 362, 363, 364, 365, 366, 367, 368, 369, 370, 371, 372, 373
840 0877 10	FAG	RENAULT	509, 510, 511, 512, 513, 514, 515, 516, 517, 518, 519, 520, 521, 522, 523, 524, 525, 526	840 1016 10	FAG	MERCEDES- BENZ	358, 359, 360, 361, 362, 363, 364, 365, 366, 367, 368, 369, 370, 371, 372, 373
840 0877 10	FAG	VAUXHALL	577, 578, 579, 580, 581, 582, 583, 584, 585, 586, 587, 588	840 1017 10	FAG	CITROËN	114, 117, 118, 119, 120, 121, 122, 123, 124, 125, 126, 127
840 0878 10	FAG	NISSAN	377, 378, 379, 380, 381, 382, 383, 384, 385, 386	840 1017 10	FAG	PEUGEOT	481, 484, 485, 486, 487, 488, 489, 490, 491, 492, 493
840 0878 10	FAG	OPEL	418, 419, 420, 421, 422, 423, 424, 425, 426, 427, 428, 429, 430, 431, 432	840 1018 10	FAG	CITROËN	114, 117, 118, 119, 120, 121, 122, 123, 124, 125, 126, 127
840 0878 10	FAG	RENAULT	509, 510, 511, 512, 513, 514, 515, 516, 517, 518, 519, 520, 521, 522, 523, 524, 525, 526	840 1018 10	FAG	PEUGEOT	481, 484, 485, 486, 487, 488, 489, 490, 491, 492, 493
840 0878 10	FAG	VAUXHALL	577, 578, 579, 580, 581, 582, 583, 584, 585, 586, 587, 588	840 1050 10	FAG	CITROËN	135, 136, 137, 138, 139
840 0879 10	FAG	FIAT	183	840 1050 10	FAG	FIAT	166, 167, 168, 169, 170, 171, 172, 173, 174, 175, 176
840 0879 10	FAG	NISSAN	388, 389, 402, 403, 404, 405, 406, 407, 408, 409, 410	840 1050 10	FAG	PEUGEOT	469, 470, 471, 472, 473, 474
840 0879 10	FAG	OPEL	444, 445, 446, 447, 448, 449, 450, 451, 452, 453, 454, 455, 456, 457, 458, 459, 460, 461, 462, 463	840 1055 10	FAG	CITROËN	135, 136, 137, 138, 139
840 0879 10	FAG	RENAULT	543, 544, 545, 546, 547, 548, 549, 550, 551, 552, 553, 554, 555, 556, 557, 558, 559, 560, 561, 562, 563	840 1055 10	FAG	FIAT	166, 167, 168, 169, 170, 171, 172, 173, 174, 175, 176
840 0879 10	FAG	VAUXHALL	598, 599, 600, 601, 602, 603, 604, 605, 606, 607, 608, 609, 610, 611, 612, 613, 614, 615	840 1055 10	FAG	PEUGEOT	469, 470, 471, 472, 473, 474
840 0880 10	FAG	FIAT	183	840 1060 10	FAG	FIAT	176, 177, 178
840 0880 10	FAG	NISSAN	388, 389, 402, 403, 404, 405, 406, 407, 408, 409, 410	840 1061 10	FAG	FIAT	176, 177, 178
840 0880 10	FAG	OPEL	444, 445, 446, 447, 448, 449, 450, 451, 452, 453, 454, 455, 456, 457, 458, 459, 460, 461, 462, 463	840 1062 10	FAG	FIAT	178, 179, 180, 181
840 0880 10	FAG	RENAULT	543, 544, 545, 546, 547, 548, 549, 550, 551, 552, 553, 554, 555, 556, 557, 558, 559, 560, 561, 562, 563	840 1062 10	FAG	PEUGEOT	475, 476, 477, 478, 479
840 0880 10	FAG	VAUXHALL	598, 599, 600, 601, 602, 603, 604, 605, 606, 607, 608, 609, 610, 611, 612, 613, 614, 615	840 1111 10	FAG	MERCEDES- BENZ	295, 296, 297, 298, 299, 300, 301, 302, 303, 304, 305, 306, 307, 308, 309, 310, 311, 312, 313, 314, 315, 316, 317, 318, 319, 320, 321, 322, 323, 324, 325, 326, 327, 328, 329, 330, 331, 332, 333, 334, 335, 336, 337, 338, 339, 340, 341, 342, 343, 344, 345, 346, 347, 348, 349, 350, 351, 352, 353, 354, 355, 356, 357
840 0908 10	FAG	FIAT	145, 146, 147, 148, 149, 150, 151	840 1111 10	FAG	VW	636, 637, 638, 639, 640, 641
840 0909 10	FAG	FIAT	145, 146, 147, 148, 149, 150, 151	840 1120 10	FAG	RENAULT	503, 504, 505, 506, 507, 508
840 0922 10	FAG	CITROËN	114, 115, 116, 118, 125	840 1121 10	FAG	RENAULT	503, 504, 505, 506, 507, 508
840 0922 10	FAG	PEUGEOT	482, 483, 486, 493, 494	840 1128 10	FAG	FORD	186, 187
840 0923 10	FAG	FIAT	182	840 1129 10	FAG	FORD	186, 187
840 0923 10	FAG	PEUGEOT	479	840 1130 10	FAG	FORD	184, 185, 186
840 0926 10	FAG	CITROËN	128	840 1131 10	FAG	FORD	184, 185, 186
840 0926 10	FAG	FIAT	152, 153, 154	840 1136 10	FAG	TOYOTA	564, 565, 566, 567, 568
840 0926 10	FAG	PEUGEOT	464	840 1142 10	FAG	NISSAN	390, 391, 392, 393, 394, 395, 396, 397, 398, 399, 400, 401
840 0937 10	FAG	FIAT	145, 146, 147, 148, 149, 150, 151	840 1142 10	FAG	OPEL	433, 434, 435, 436, 437, 438, 439, 440, 441, 442, 443, 444
				840 1142 10	FAG	RENAULT	526, 527, 528, 529, 530, 531, 532, 533, 534, 535, 536, 537, 538, 539, 540, 541, 542
				840 1142 10	FAG	VAUXHALL	589, 590, 591, 592, 593, 594, 595, 596, 597
				840 1143 10	FAG	NISSAN	390, 391, 392, 393, 394, 395, 396, 397, 398, 399, 400, 401
				840 1143 10	FAG	OPEL	433, 434, 435, 436, 437, 438, 439, 440, 441, 442, 443, 444
				840 1143 10	FAG	RENAULT	526, 527, 528, 529, 530, 531, 532, 533, 534, 535, 536, 537, 538, 539, 540, 541, 542
				840 1143 10	FAG	VAUXHALL	589, 590, 591, 592, 593, 594, 595, 596, 597
				840 1155 10	FAG	VW	615, 616, 617, 618, 619, 620, 621, 622, 623, 624, 625, 626, 627, 628, 629, 630, 631, 632, 633, 634, 635





*Unique LCV Application

**Numerische Liste / Numerical listing / Liste numérique / Listado numérico / Elenco numerico /
Listy numerycznej / Перечень артикулов**

SCHAEFFLER				SCHAEFFLER			
840 1156 10	FAG	VW	615, 616, 617, 618, 619, 620, 621, 622, 623, 624, 625, 626, 627, 628, 629, 630, 631, 632, 633, 634, 635	FB 5PK1148	INA	FIAT	147
				FB 5PK1200	INA	RENAULT	496, 498, 499
				FB 5PK1219	INA	CITROËN	114, 115, 125
				FB 5PK1219	INA	PEUGEOT	482, 486
840 1173 10	FAG	MERCEDES- BENZ	291, 293, 294, 295	FB 5PK1255	INA	CITROËN	114, 115, 125
				FB 5PK1255	INA	PEUGEOT	482, 486
840 1173 10	FAG	VW	641, 642	FB 5PK1750	INA	RENAULT	500, 501
840 1189 10	FAG	NISSAN	386, 387, 388	FB 5PK725	INA	CITROËN	114, 115
840 1190 10	FAG	NISSAN	386, 387, 388	FB 5PK725	INA	PEUGEOT	482
840 1198 10	FAG	MITSUBISHI	376	FB 5PK860	INA	CITROËN	114, 115, 125
840 1199 10	FAG	MITSUBISHI	376	FB 5PK860	INA	PEUGEOT	482, 486
840 1223 10	FAG	NISSAN	386, 387, 388	FB 5PK865	INA	TOYOTA	568
840 1279 10	FAG	FORD	188, 210, 211, 212, 213	FB 5PK940	INA	FIAT	147, 148
FB 10X1090	INA	HYUNDAI	221	FB 5PK940	INA	OPEL	412, 413
FB 10X1100	INA	HYUNDAI	221	FB 5PK940	INA	VAUXHALL	571, 572
FB 10X710	INA	CITROËN	114, 115	FB 6APK1005	INA	CITROËN	117, 123, 127
FB 10X710	INA	PEUGEOT	482	FB 6APK1005	INA	PEUGEOT	480, 481, 485, 490, 492
FB 13X900	INA	MITSUBISHI	376	FB 6APK1020	INA	CITROËN	117, 120, 121, 122
FB 13X925	INA	HYUNDAI	221	FB 6APK1020	INA	PEUGEOT	485, 488, 489
FB 13X950	INA	HYUNDAI	221	FB 6DPK1195	INA	VW	618, 624, 643, 644, 647, 657, 659
FB 13X975	INA	MERCEDES- BENZ	301, 305, 322, 348	FB 6DPK1215	INA	VW	620, 621, 622, 626, 642, 643, 644, 656, 657, 658
FB 3PK715	INA	FORD	187, 210	FB 6EPK873	INA	CITROËN	135, 136, 137, 138
FB 3PK738	INA	RENAULT	495	FB 6EPK873	INA	FIAT	166
FB 3PK750	INA	RENAULT	495	FB 6EPK873	INA	FORD	188, 194, 195, 196, 197, 198, 199, 200, 201, 202, 211, 212, 213
FB 3PK915	INA	FIAT	144, 147	FB 6EPK873	INA	PEUGEOT	470, 471, 472
FB 4EPK1022	INA	FIAT	145, 146, 176	FB 6PK1043	INA	PEUGEOT	493
FB 4EPK1102	INA	CITROËN	138	FB 6PK1050	INA	VW	620, 621, 622, 626
FB 4EPK1102	INA	FIAT	175	FB 6PK1053	INA	FIAT	149, 150
FB 4EPK1102	INA	IVECO	228, 229, 233, 234, 235, 236, 244, 245, 246, 247, 248, 249, 250, 251, 256, 257, 258, 259, 261, 262, 263, 264, 265, 266, 267, 268, 269, 270, 271, 272, 273, 278	FB 6PK1053	INA	IVECO	224, 225, 228, 229, 231, 232, 233, 234, 235
FB 4EPK1102	INA	PEUGEOT	472, 473, 474	FB 6PK1070	INA	VW	617, 619, 623, 624, 625, 626, 627, 630, 632, 633, 634
FB 4EPK903	INA	FIAT	158, 159, 167, 168, 169, 171, 172	FB 6PK1078	INA	VW	636, 637, 638, 639, 645, 646, 648, 649, 650, 651, 658, 659, 661, 662, 663, 666, 667, 668, 670, 671, 672, 673, 674, 675, 676
FB 4EPK903	INA	IVECO	222, 223, 225, 226, 227, 228, 230, 231, 232, 236, 237, 238, 239, 240, 241, 242, 243, 244, 245, 250, 251, 252, 253, 254, 255, 276, 277, 278, 282, 283, 284	FB 6PK1090	INA	FIAT	156, 158
FB 4EPK922	INA	CITROËN	135, 136, 137, 138	FB 6PK1090	INA	VW	666, 667, 669, 671, 672, 673, 674, 675, 677
FB 4EPK922	INA	FIAT	166	FB 6PK1093	INA	CITROËN	129
FB 4EPK922	INA	FORD	188, 194, 195, 196, 197, 198, 199, 200, 201, 202, 211, 212, 213	FB 6PK1100	INA	FIAT	158
FB 4EPK922	INA	PEUGEOT	470, 471, 472	FB 6PK1100	INA	PEUGEOT	464, 465
FB 4PK1062	INA	HYUNDAI	221	FB 6PK1100	INA	VW	616, 617
FB 4PK1538	INA	RENAULT	495	FB 6PK1120	INA	VW	643, 644, 647, 657, 659
FB 4PK668	INA	FIAT	140, 141, 144, 147, 177, 178	FB 6PK1125	INA	RENAULT	502
FB 4PK668	INA	OPEL	416	FB 6PK1125	INA	VW	618, 624
FB 4PK668	INA	VAUXHALL	575	FB 6PK1130	INA	RENAULT	497
FB 4PK673	INA	FIAT	144	FB 6PK1138	INA	VW	620, 621, 622, 626, 642, 643, 644, 656, 657, 658
FB 4PK698	INA	FIAT	144	FB 6PK1148	INA	NISSAN	377, 378, 379, 381, 382, 403, 409
FB 4PK725	INA	RENAULT	507	FB 6PK1148	INA	OPEL	421, 424, 428, 431, 448, 454, 459
FB 4PK735	INA	FORD	188, 189	FB 6PK1148	INA	RENAULT	511, 517, 522
FB 4PK755	INA	CITROËN	127, 128, 129, 130, 131	FB 6PK1148	INA	VAUXHALL	578, 582, 587, 602, 608, 612
FB 4PK755	INA	FIAT	152, 154, 155, 158	FB 6PK1153	INA	NISSAN	378, 379, 381, 382, 383, 403, 409
FB 4PK755	INA	PEUGEOT	463, 464, 465, 466	FB 6PK1153	INA	PEUGEOT	479, 494
FB 4PK840	INA	FIAT	144	FB 6PK1153	INA	RENAULT	547, 548, 553, 558
FB 4PK863	INA	CITROËN	114, 115, 124	FB 6PK1165	INA	FIAT	175
FB 4PK905	INA	RENAULT	495	FB 6PK1180	INA	FIAT	146, 152, 155
FB 4PK928	INA	RENAULT	495	FB 6PK1180	INA	OPEL	410, 411
FB 4PK985	INA	FIAT	158, 159	FB 6PK1180	INA	VAUXHALL	569, 570
FB 4PK985	INA	IVECO	222, 223, 226, 227, 230, 236, 237, 239, 242, 252	FB 6PK1183	INA	CITROËN	127, 128, 130, 131
FB 5PK1100	INA	CITROËN	131, 132, 133, 134	FB 6PK1183	INA	PEUGEOT	463, 465, 466
FB 5PK1100	INA	FIAT	153, 161, 162, 163, 164, 165	FB 6PK1183	INA	VW	652
FB 5PK1100	INA	PEUGEOT	467, 468, 469	FB 6PK1190	INA	PEUGEOT	479
FB 5PK1125	INA	NISSAN	405, 406	FB 6PK1200	INA	NISSAN	386, 387, 388
FB 5PK1125	INA	OPEL	446, 447, 452, 453, 457, 458	FB 6PK1200	INA	RENAULT	496, 497, 498, 499, 500, 503, 504, 505, 506, 507, 508
FB 5PK1125	INA	RENAULT	550	FB 6PK1203	INA	CITROËN	119, 123
FB 5PK1125	INA	VAUXHALL	601, 606	FB 6PK1203	INA	PEUGEOT	486, 490
FB 5PK1133	INA	RENAULT	496, 498, 499, 500	FB 6PK1210	INA	RENAULT	502
				FB 6PK1218	INA	FIAT	179, 180, 181
				FB 6PK1218	INA	GAZ	216, 217





*Unique LCV Application

**Numerische Liste / Numerical listing / Liste numérique / Listado numérico / Elenco numerico /
Listy numerycznej / Перечень артикулов**

SCHAEFFLER				SCHAEFFLER			
FB 6PK1218	INA	IVECO	228, 229, 233, 234, 235, 236, 244, 245, 246, 247, 248, 249, 250, 251, 256, 257, 258, 259, 261, 262, 263, 264, 265, 266, 267, 268, 269, 270, 271, 272, 273, 278, 279	FB 6PK1795	INA	VAUXHALL	578, 580, 582, 585, 587, 598, 599, 601, 602, 604, 606, 608, 613
FB 6PK1218	INA	RENAULT	502	FB 6PK1815	INA	FIAT	149, 150
FB 6PK1250	INA	FORD	183, 186	FB 6PK1830	INA	RENAULT	543, 544, 545, 549, 550, 554, 555
FB 6PK1250	INA	OPEL	413, 414	FB 6PK1835	INA	NISSAN	378, 379, 381, 382, 383, 402, 403, 405, 406, 409
FB 6PK1264	INA	VAUXHALL	573	FB 6PK1835	INA	RENAULT	509, 510, 511, 517, 520, 521, 522, 544, 545, 547, 548, 550, 553, 555, 558
FB 6PK1264	INA	VW	655, 656, 665, 666	FB 6PK1955	INA	FORD	189, 190, 191
FB 6PK1275	INA	OPEL	414	FB 6PK2000	INA	VW	639, 640, 641
FB 6PK1275	INA	VAUXHALL	574	FB 6PK2080	INA	VW	641
FB 6PK1310	INA	FIAT	145, 146	FB 6PK2100	INA	FORD	216
FB 6PK1340	INA	FORD	187, 188, 210, 211	FB 6PK2100	INA	MERCEDES- BENZ	294
FB 6PK1370	INA	FIAT	142, 143, 144, 165	FB 6PK2115	INA	MERCEDES- BENZ	294
FB 6PK1370	INA	GAZ	216, 217	FB 6PK2145	INA	VW	641
FB 6PK1370	INA	OPEL	417	FB 6PK2155	INA	VW	642
FB 6PK1370	INA	VAUXHALL	575, 576	FB 6PK2196	INA	MERCEDES- BENZ	291, 292, 295
FB 6PK1413	INA	FORD	187, 210, 214, 215	FB 6PK2215	INA	MERCEDES- BENZ	294, 298, 299, 300, 301, 302, 303, 304, 307, 313, 314, 315, 317, 318, 319, 320, 324, 325, 326, 335, 336, 337, 342, 343, 345, 346, 347, 350, 351, 360, 364, 365, 367, 368
FB 6PK1413	INA	MERCEDES- BENZ	296, 308, 309, 328, 329, 330, 331, 332, 333, 338, 339, 340, 352, 353, 354, 355, 356	FB 6PK2260	INA	MERCEDES- BENZ	297, 298, 299, 300, 301, 302, 303, 304, 305, 306, 312, 313, 314, 315, 316, 317, 318, 320, 321, 322, 323, 335, 341, 342, 343, 344, 345, 348, 349, 357, 358, 359, 360, 361, 362, 363, 364, 366, 367
FB 6PK1432	INA	VW	615, 616	FB 6PK2264	INA	MERCEDES- BENZ	291, 292, 295, 296, 297
FB 6PK1460	INA	FORD	214, 215	FB 6PK2270	INA	MERCEDES- BENZ	291, 292, 295, 296, 297, 357, 358, 359, 360, 361, 362, 363, 364, 366, 367
FB 6PK1468	INA	CITROËN	127, 128, 130, 131	FB 6PK2280	INA	FORD	202, 203
FB 6PK1468	INA	FIAT	152, 155	FB 6PK2280	INA	MERCEDES- BENZ	297, 357, 359, 361, 362, 363, 364, 366, 367
FB 6PK1468	INA	PEUGEOT	463, 465, 466	FB 6PK2285	INA	MERCEDES- BENZ	298, 299, 300, 301, 302, 303, 305, 312, 313, 314, 315, 317, 318, 321, 322, 341, 342, 343, 344, 348, 358, 360
FB 6PK1495	INA	MITSUBISHI	376	FB 6PK2315	INA	MERCEDES- BENZ	369, 370
FB 6PK1503	INA	FORD	183, 186	FB 6PK2403	INA	MERCEDES- BENZ	310, 311, 334, 340, 356, 373
FB 6PK1510	INA	MITSUBISHI	376	FB 6PK2520	INA	VW	639, 640, 641
FB 6PK1520	INA	FIAT	139	FB 6PK737	INA	VW	616, 617, 631
FB 6PK1525	INA	FIAT	139, 140, 176, 177	FB 6PK745	INA	VW	628, 629
FB 6PK1525	INA	OPEL	415	FB 6PK800	INA	CITROËN	117, 120, 121, 122, 123, 124, 125, 126, 127
FB 6PK1525	INA	VAUXHALL	574	FB 6PK800	INA	FORD	185, 187
FB 6PK1555	INA	FORD	186	FB 6PK800	INA	PEUGEOT	480, 481, 485, 486, 487, 488, 489, 490, 491, 492, 494, 495
FB 6PK1555	INA	VW	645, 646, 648, 649, 650, 651, 658, 659, 661, 662, 663, 666, 667, 668, 669, 670, 671, 672, 673, 674, 675, 676, 677	FB 6PK844	INA	VW	636, 637, 638, 639
FB 6PK1565	INA	FIAT	177	FB 6PK862	INA	PEUGEOT	493
FB 6PK1580	INA	VW	652	FB 6PK875	INA	CITROËN	128, 130, 131
FB 6PK1600	INA	OPEL	414	FB 6PK875	INA	PEUGEOT	465, 466
FB 6PK1600	INA	VAUXHALL	574	FB 6PK900	INA	VW	618, 619, 624
FB 6PK1613	INA	VW	636, 637, 638, 639	FB 6PK948	INA	CITROËN	131, 132, 133, 134
FB 6PK1640	INA	FORD	188, 189, 195, 197, 198, 199, 200, 201, 202	FB 6PK948	INA	FIAT	153, 161, 162, 163, 164, 165
FB 6PK1640	INA	PEUGEOT	472	FB 6PK948	INA	FORD	187
FB 6PK1670	INA	CITROËN	135, 136, 137, 138	FB 6PK948	INA	PEUGEOT	467, 468, 469
FB 6PK1670	INA	FIAT	139, 140, 166, 177	FB 6PK948	INA	VW	620, 621, 622, 626
FB 6PK1670	INA	FORD	188, 195, 197, 198, 199, 200, 201, 211, 212, 213	FB 6PK962	INA	CITROËN	122
FB 6PK1670	INA	PEUGEOT	470, 471, 472	FB 6PK975	INA	VW	636, 637, 638, 639
FB 6PK1685	INA	VW	642	FB 6PK995	INA	CITROËN	131, 132, 133, 134
FB 6PK1693	INA	VW	615, 616	FB 6PK995	INA	FIAT	153, 161, 162, 163, 164, 165
FB 6PK1698	INA	CITROËN	119, 123	FB 6PK995	INA	PEUGEOT	467, 468, 469
FB 6PK1698	INA	PEUGEOT	486, 490				
FB 6PK1705	INA	FIAT	144, 165, 178				
FB 6PK1705	INA	OPEL	417				
FB 6PK1705	INA	VAUXHALL	575, 576				
FB 6PK1708	INA	FIAT	142, 143, 144, 179				
FB 6PK1708	INA	PEUGEOT	479				
FB 6PK1718	INA	CITROËN	114				
FB 6PK1718	INA	VW	641				
FB 6PK1750	INA	VW	641				
FB 6PK1780	INA	FORD	191				
FB 6PK1795	INA	NISSAN	378, 379, 381, 382, 383, 403, 409				
FB 6PK1795	INA	OPEL	418, 421, 422, 424, 428, 431, 444, 445, 446, 447, 448, 452, 453, 454, 455, 456, 457, 458, 459				
FB 6PK1795	INA	RENAULT	508, 509, 511, 515, 517, 520, 522, 543, 544, 545, 547, 548, 549, 550, 553, 555, 557, 558				

*Unique LCV Application

































**Numerische Liste / Numerical listing / Liste numérique / Listado numérico / Elenco numerico /
Listy numerycznej / Перечень артикулов**

SCHAEFFLER				SCHAEFFLER			
FB 7PK1076	INA	FIAT	158, 159, 167, 168, 169, 171, 172, 173	FB 7PK1973	INA	OPEL	445, 446, 451, 452, 456, 457
FB 7PK1093	INA	TOYOTA	564, 565	FB 7PK1973	INA	RENAULT	526, 527, 528, 530, 531, 532, 535, 536, 537, 545, 551, 556
FB 7PK1103	INA	NISSAN	380, 381, 382, 383, 403	FB 7PK1973	INA	VAUXHALL	599, 600, 605, 610
FB 7PK1103	INA	OPEL	419, 421, 424, 426, 428, 429, 431	FB 7PK2000	INA	NISSAN	406
FB 7PK1103	INA	RENAULT	509, 510, 511, 517, 518, 519, 520, 521, 522	FB 7PK2000	INA	OPEL	445, 446, 451, 452, 456, 457
FB 7PK1103	INA	VAUXHALL	576, 578, 582, 587	FB 7PK2000	INA	VAUXHALL	599, 600, 605, 610
FB 7PK1113	INA	NISSAN	378, 384, 385	FB 7PK2035	INA	MERCEDES-BENZ	296, 308, 309, 310, 328, 329, 330, 331, 332, 333, 338, 339, 340, 352, 353, 354, 355, 356, 369, 371
FB 7PK1113	INA	OPEL	420, 423, 425, 427, 430, 448, 449, 453, 459	FB 7PK2045	INA	MERCEDES-BENZ	308, 309, 310, 328, 329, 330, 331, 332, 333, 338, 339, 340, 352, 353, 354, 355, 356
FB 7PK1113	INA	RENAULT	516, 519, 521	FB 7PK2265	INA	HYUNDAI	217, 218, 219, 220, 221
FB 7PK1113	INA	VAUXHALL	577, 578, 581, 583, 586, 587, 601, 603, 607, 608, 612, 613	FB 7PK2285	INA	HYUNDAI	220, 221, 222
FB 7PK1145	INA	NISSAN	380, 381, 382, 383, 388, 403	FB 7PK2683	INA	FORD	204, 205, 206, 207, 208, 209, 210
FB 7PK1145	INA	OPEL	421	FB 7PK2710	INA	FORD	191, 192, 193
FB 7PK1145	INA	RENAULT	509, 511, 515, 517, 520, 522	FB 7PK2843	INA	FORD	209, 210
FB 7PK1325	INA	FIAT	183	FB 7PK2875	INA	FORD	191, 192, 193, 204, 206, 207, 208, 209
FB 7PK1325	INA	IVECO	222, 223, 225, 226, 227, 228, 230, 231, 232, 236, 237, 238, 239, 240, 241, 242, 243, 244, 245, 250, 251, 252, 253, 254, 255, 276, 277, 278, 282, 283				
FB 7PK1325	INA	OPEL	460, 461, 462, 463				
FB 7PK1325	INA	RENAULT	559, 560, 561, 562				
FB 7PK1325	INA	VAUXHALL	614, 615				
FB 7PK1605	INA	RENAULT	503				
FB 7PK1642	INA	RENAULT	513, 514				
FB 7PK1668	INA	RENAULT	533, 536, 537				
FB 7PK1675	INA	FIAT	183				
FB 7PK1675	INA	RENAULT	541, 542, 559, 560, 561, 562, 563				
FB 7PK1685	INA	FIAT	183				
FB 7PK1685	INA	NISSAN	391				
FB 7PK1685	INA	OPEL	445, 446, 456, 457				
FB 7PK1685	INA	RENAULT	526, 527, 528, 529, 530, 531, 532, 533, 534, 535, 536, 537, 538, 539, 540, 541, 559, 560, 561, 562, 563				
FB 7PK1715	INA	HYUNDAI	217, 218, 219, 220, 221				
FB 7PK1730	INA	HYUNDAI	220, 221, 222				
FB 7PK1741	INA	NISSAN	406				
FB 7PK1741	INA	OPEL	445, 446, 451, 456, 457				
FB 7PK1741	INA	RENAULT	545, 551, 556				
FB 7PK1741	INA	VAUXHALL	599, 605, 610				
FB 7PK1753	INA	NISSAN	376, 377, 386				
FB 7PK1795	INA	NISSAN	378, 380, 381, 382, 383, 384, 385, 403, 409, 410				
FB 7PK1795	INA	OPEL	419, 420, 421, 423, 424, 425, 426, 427, 428, 429, 430, 431, 448, 449, 453, 459				
FB 7PK1795	INA	RENAULT	509, 510, 511, 512, 515, 516, 517, 518, 519, 520, 521, 522, 523, 524, 546, 548, 552, 553, 558, 559				
FB 7PK1795	INA	VAUXHALL	576, 577, 578, 579, 581, 582, 583, 586, 587, 601, 603, 607, 608, 612, 613				
FB 7PK1835	INA	NISSAN	380, 383, 384, 385, 403, 409, 410				
FB 7PK1835	INA	OPEL	420, 423, 425, 427, 430, 448, 449, 453, 459				
FB 7PK1835	INA	RENAULT	510, 511, 512, 515, 516, 518, 519, 523, 524, 546, 548, 552, 553, 558, 559				
FB 7PK1835	INA	VAUXHALL	577, 586, 601, 603, 607, 608, 612, 613				
FB 7PK1920	INA	OPEL	421, 425, 432				
FB 7PK1920	INA	RENAULT	513, 519, 525				
FB 7PK1920	INA	VAUXHALL	579, 584, 588				
FB 7PK1933	INA	TOYOTA	564, 566, 567, 568, 569				
FB 7PK1973	INA	MERCEDES-BENZ	296, 308, 309, 310, 328, 329, 330, 331, 332, 333, 338, 339, 340, 352, 353, 354, 355, 356				
FB 7PK1973	INA	NISSAN	390, 392, 393, 394, 396, 397, 398, 406				

*Unique LCV Application



Part groups

GearBOX	LuK GearBOX manual gearbox repair kit
	Multi-ribbed belt tensioner lever repair kit
	Alternator pulley
	Crankshaft pulley
	Crankshaft pulley kit
	Timing belt tensioner
	Valve train finger follower
	Flywheel bolt kit
	Multi-ribbed belt vibration damper
	Timing belt vibration damper
	Flywheel
	Multi-ribbed belt tensioner lever
	Timing belt tensioner lever
	V-belt tensioner pulley
	Multi-ribbed belt tensioner pulley
	Timing belt tensioner pulley
	Tie rod
	Tie rod end
	Stabilizer
	Rod/strut, stabilizer
	Timing chain kit
	Camshaft phaser solenoid valve/Camshaft phaser solenoid valve with housing
	Roller type mechanical tappet
	Ball joint
	Deflection/guide pulley
	Rocker/tappet
	Water pump
	Multi-ribbed belt kit with water pump
	Timing belt kit with water pump
	Tool set, timing settings
	Strut mount bearing
	Timing belt kit
	Central valve

Further information:
www.schaeffler.com/aftermarket