

**RIDUTTORI
EPICICLOIDALI**

**PLANETARY
GEARBOXES**

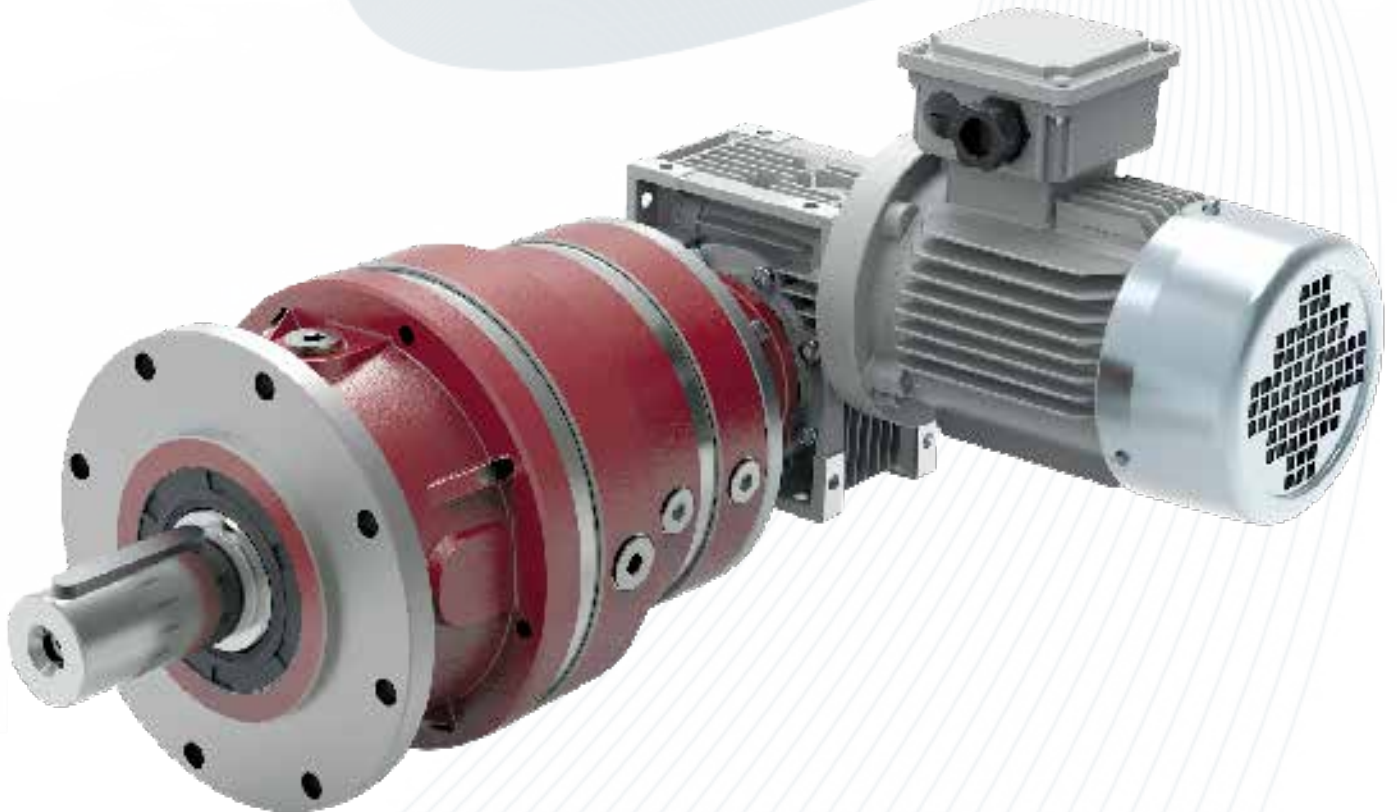

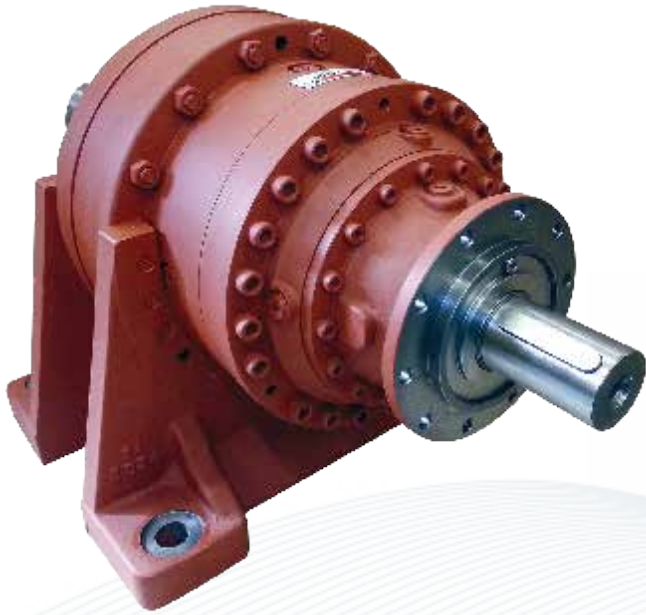

INDICE DEI CONTENUTI · INDEX OF CONTENT

A	INTRODUZIONE	INTRODUCTION	A1
	Designazione	<i>Designation</i>	A2
	Caratteristiche tecniche	<i>Technical features</i>	A6
	Installazione e manutenzione	<i>Installation and maintenance</i>	A10
	Lubrificazione	<i>Lubrication</i>	A12
	Posizioni di montaggio	<i>Mounting positions</i>	A18
B	CPHL CHPLB 1000		B1
	Dati Tecnici	<i>Technical data</i>	B2
	Dimensioni uscita CMS	CMS Output dimensions	B4
	Dimensioni uscita CMC	CMC Output dimensions	B6
	Dimensioni uscita CPS	CPS Output dimensions	B8
	Dimensioni uscita CPC	CPC Output dimensions	B10
	Dimensioni uscita CF	CF Output dimensions	B12
	Dimensioni uscita CFS	CFS Output dimensions	B14
	Dimensioni uscita CCPC	CCPC Output dimensions	B16
	Accessori	Accessories	B18
	Carichi in uscita	Output loads	B19
C	CPHL CHPLB 1600		C1
	Dati Tecnici	<i>Technical data</i>	C2
	Dimensioni uscita CMS	CMS Output dimensions	C4
	Dimensioni uscita CMC	CMC Output dimensions	C6
	Dimensioni uscita CPS	CPS Output dimensions	C8
	Dimensioni uscita CPC	CPC Output dimensions	C10
	Dimensioni uscita CF	CF Output dimensions	C12
	Dimensioni uscita CFS	CFS Output dimensions	C14
	Dimensioni uscita CCPC	CCPC Output dimensions	C16
	Accessori	Accessories	C18
	Carichi in uscita	Output loads	C19
D	CPHL CHPLB 2500		D1
	Dati Tecnici	<i>Technical data</i>	D2
	Dimensioni uscita CMS	CMS Output dimensions	D4
	Dimensioni uscita CMC	CMC Output dimensions	D6
	Dimensioni uscita CPS	CPS Output dimensions	D8
	Dimensioni uscita CPC	CPC Output dimensions	D10
	Dimensioni uscita CF	CF Output dimensions	D12
	Dimensioni uscita CFS	CFS Output dimensions	D14
	Dimensioni uscita CCPC	CCPC Output dimensions	D16
	Accessori	Accessories	D18
	Carichi in uscita	Output loads	D19

INDICE DEI CONTENUTI · INDEX OF CONTENT

E	CPHL CHPLB 5000		E1
	Dati Tecnici	<i>Technical data</i>	E2
	Dimensioni uscita CMS	CMS Output dimensions	E4
	Dimensioni uscita CMC	CMC Output dimensions	E6
	Dimensioni uscita CPS	CPS Output dimensions	E8
	Dimensioni uscita CPC	CPC Output dimensions	E10
	Dimensioni uscita CF	CF Output dimensions	E12
	Dimensioni uscita CFS	CFS Output dimensions	E14
	Dimensioni uscita CCPC	CCPC Output dimensions	E16
	Accessori	Accessories	E18
	Carichi in uscita	Output loads	E19
F	CPHL CHPLB 7000		F1
	Dati Tecnici	<i>Technical data</i>	F2
	Dimensioni uscita CPS	CPS Output dimensions	F4
	Dimensioni uscita CPC	CPC Output dimensions	F6
	Dimensioni uscita CF	CF Output dimensions	F8
	Dimensioni uscita CFS	CFS Output dimensions	F10
	Dimensioni uscita CCPC	CCPC Output dimensions	F12
	Accessori	Accessories	F14
	Carichi in uscita	Output loads	F15
G	CPHL CHPLB 10000		G1
	Dati Tecnici	<i>Technical data</i>	G2
	Dimensioni uscita CMS	CMS Output dimensions	G4
	Dimensioni uscita CMC	CMC Output dimensions	G6
	Dimensioni uscita CF	CF Output dimensions	G8
	Dimensioni uscita CFS	CFS Output dimensions	G10
	Dimensioni uscita CCPC	CCPC Output dimensions	G12
	Accessori	Accessories	G14
	Carichi in uscita	Output loads	G15
H	CPHL CHPLB 16000		H1
	Dati Tecnici	<i>Technical data</i>	H2
	Dimensioni uscita CMS	CMS Output dimensions	H4
	Dimensioni uscita CMC	CMC Output dimensions	H6
	Dimensioni uscita CPS	CPS Output dimensions	H8
	Dimensioni uscita CPC	CPC Output dimensions	H10
	Dimensioni uscita CF	CF Output dimensions	H12
	Dimensioni uscita CFS	CFS Output dimensions	H14
	Dimensioni uscita CCPC	CCPC Output dimensions	H16
	Accessori	Accessories	H18
	Carichi in uscita	Output loads	H19



INDICE DEI CONTENUTI · INDEX OF CONTENT

I	CPHL CHPLB 18000		I1
	Dati Tecnici	<i>Technical data</i>	I2
	Dimensioni uscita CMS	CMS Output dimensions	I4
	Dimensioni uscita CMC	CMC Output dimensions	I6
	Dimensioni uscita CPS	CPS Output dimensions	I8
	Dimensioni uscita CPC	CPC Output dimensions	I10
	Dimensioni uscita CF	CF Output dimensions	I12
	Dimensioni uscita CFS	CFS Output dimensions	I14
	Dimensioni uscita CCPC	CCPC Output dimensions	I16
	Accessori	Accessories	I18
	Carichi in uscita	Output loads	I19
L	CPHL CHPLB 25000		L1
	Dati Tecnici	<i>Technical data</i>	L2
	Dimensioni uscita CMS	CMS Output dimensions	L4
	Dimensioni uscita CMC	CMC Output dimensions	L6
	Dimensioni uscita CF	CF Output dimensions	L8
	Dimensioni uscita CFS	CFS Output dimensions	L10
	Dimensioni uscita CCPC	CCPC Output dimensions	L12
	Accessori	Accessories	L14
	Carichi in uscita	Output loads	L15
M	CPHL CHPLB 30000		M1
	Dati Tecnici	<i>Technical data</i>	M2
	Dimensioni uscita CMS	CMS Output dimensions	M4
	Dimensioni uscita CMC	CMC Output dimensions	M6
	Dimensioni uscita CF	CF Output dimensions	M8
	Dimensioni uscita CFS	CFS Output dimensions	M10
	Dimensioni uscita CCPC	CCPC Output dimensions	M12
	Accessori	Accessories	M14
	Carichi in uscita	Output loads	M15
N	CPHL CHPLB 35000		N1
	Dati Tecnici	<i>Technical data</i>	N2
	Dimensioni uscita CMS	CMS Output dimensions	N4
	Dimensioni uscita CMC	CMC Output dimensions	N6
	Dimensioni uscita CF	CF Output dimensions	N8
	Dimensioni uscita CFS	CFS Output dimensions	N10
	Dimensioni uscita CCPC	CCPC Output dimensions	N12
	Accessori	Accessories	N14
	Carichi in uscita	Output loads	N15

INDICE DEI CONTENUTI · INDEX OF CONTENT

P	APPENDICE	APPENDIX	P1
	Motori Elettrici	Electric Motors	P1
	Predisposizioni per Riduttori a Vite senza fine	Worm Gearboxes connections	P6
	Alberi maschio in entrata	Male input shafts	P7
	Predisposizioni per motori idraulici	Hydraulic motors connections	P8
	Freni idraulici	Hydraulic brakes	P10
	Condizioni generali di vendita	General sales conditions	P11





INTRODUZIONE · INTRODUCTION

Ingombri ridotti, elevata affidabilità e semplicità costruttiva sono tra le caratteristiche dei nuovi riduttori epicicloidali CHIARAVALLI.

Altro grande vantaggio è l'elevata modularità di configurazione che permette di assemblare in ingresso motori elettrici, idraulici, vite senza fine (serie CHM CHIARAVALLI) oppure alberi maschio cilindrici.

Diverse configurazioni di alberi e flange in uscita permettono l'utilizzo di questi riduttori in parecchie applicazioni industriali.

Disponibili nella versione lineare (CHPL) o in quella angolare (CHPLB), i riduttori epicicloidali della serie CHIARAVALLI comprendono 11 grandezze con coppie trasmissibili che vanno da 1000 Nm a 35000 Nm e rapporti di riduzione da 3.55:1 sino a 3422:1 e oltre per riduttori con più di 4 stadi di riduzione (ordinabili a richiesta).

I riduttori CHIARAVALLI sono normalmente forniti con fondo preparatorio per la verniciatura.

High reliability, compact volumes and easy construction are among the main characteristics of new CHIARAVALLI planetary gearboxes.

As one of the main advantages, our planetary gearboxes can be easily assembled with electric and hydraulic motors, worm gearboxes (CHM series) and input shafts.

Furthermore, they can be assembled with different output flanges or shafts, all these characteristics make them suitable for several industrial applications.

CHIARAVALLI planetary gear boxes are available in linear version (CHPL) and angular one (CHPLB).

Our range covers 11 transmission sizes, from 1000 Nm up to 35000 Nm, rate reductions from 3.55:1 to 3422:1 and more with four reduction stages (these available upon request).

CHIARAVALLI planetary gearboxes are available at anti rusted treated blank surface ready to be painted.

DESIGNAZIONE · DESIGNATION

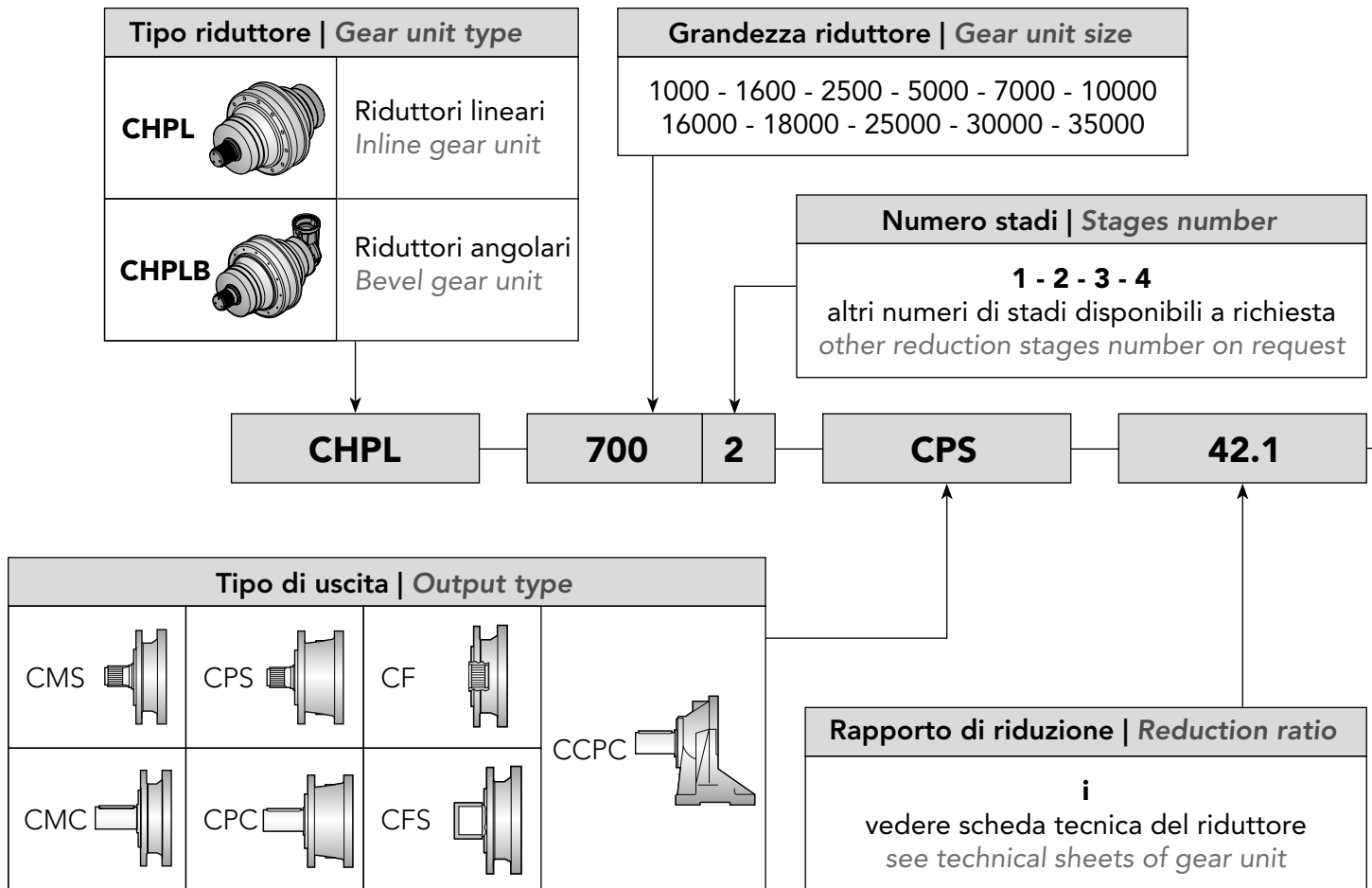

Esempio designazione | Example of designation:

1 CHPL 7002 CPS 42.1 IEC90 B5 CHYZ CHFF

Riduttore epicicloidale in linea **CHPL**, taglia **7000** a **2** stadi, uscita tipo **CPS** e rapporto di riduzione **i=42.1**, in ingresso predisposizione per attacco motore elettrico **IEC90**.

Posizione di montaggio dell'intero gruppo **B5** e con accessori in uscita **CHYZ** e **CHFF**.

In line CHPL planetary gearbox, size 7000 with 2 stages, output flange CPS ratio i=42.1 and motor mounting flange for electrical motor IEC90.

Mounting position B5 with output accessories CHYZ and CHFF.

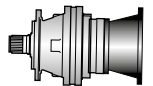
**2** CHPL 7002 CPS 42.1 CM42 B5 CHYZ CHFF

Riduttore epicicloidale in linea **CHPL**, taglia **7000** a **2** stadi, uscita tipo **CPS** e rapporto di riduzione **i=42.1**, in ingresso albero maschio **CM42**. Posizione di montaggio dell'intero gruppo **B5** e con accessori in uscita **CHYZ** e **CHFF**.

In line CHPL planetary gearbox, size 7000 with 2 stages, output flange CPS ratio i=42.1 and male shaft CM42.

Mounting position B5 with output accessories CHYZ and CHFF.

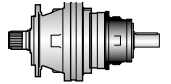
**3** CHPL 7002 CPS 42.1 H.2074.013.018 B5 CHYZ CHFF

Riduttore epicicloidale in linea **CHPL**, taglia **7000** a **2** stadi, uscita tipo **CPS** e rapporto di riduzione **i=42.1**, in ingresso predisposizione per montaggio motore idraulico cod.2074.013.018. SAUER-DANFOSS. Posizione di montaggio dell'intero gruppo **B5** e con accessori in uscita **CHYZ** e **CHFF**.

In line CHPL planetary gearbox, size 7000 with 2 stages, output flange CPS ratio i=42.1 and motor mounting flange for hydraulic motor code 2074.013.018 SAUER DANFOS. Mounting position B5 with output accessories CHYZ and CHFF.

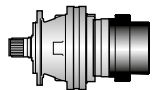
**4** CHPL 7002 CPS 42.1 CHM63 20 90B14 C1 CHYZ CHFF

Riduttore epicicloidale in linea **CHPL**, taglia **7000** a **2** stadi, uscita tipo **CPS** e rapporto di riduzione **i=42.1**, in ingresso riduttore **VSF CHM63** con **iVSF=20** e flangia motore **90B14**. Posizione di montaggio dell'intero gruppo **C1** e con accessori in uscita **CHYZ** e **CHFF**.

In line CHPL planetary gearbox, size 7000 at 2 stages, output flange CPS ratio i=42.1, input reducer VSF CHM63 iVSF=20 and motor mounting flange 90B14.

Mounting position C1 with output accessories CHYZ and CHFF.

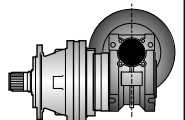



DESIGNAZIONE · DESIGNATION

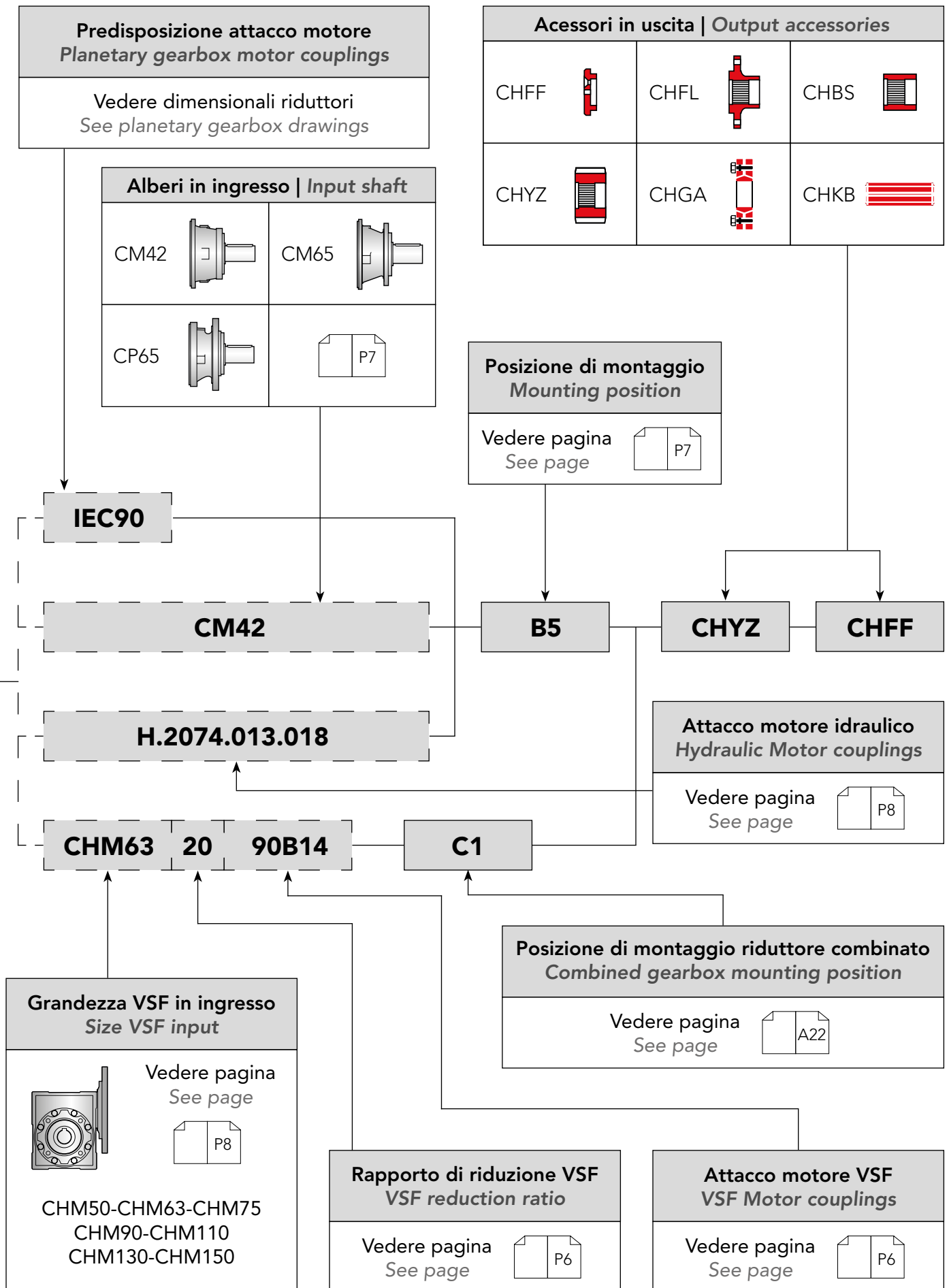

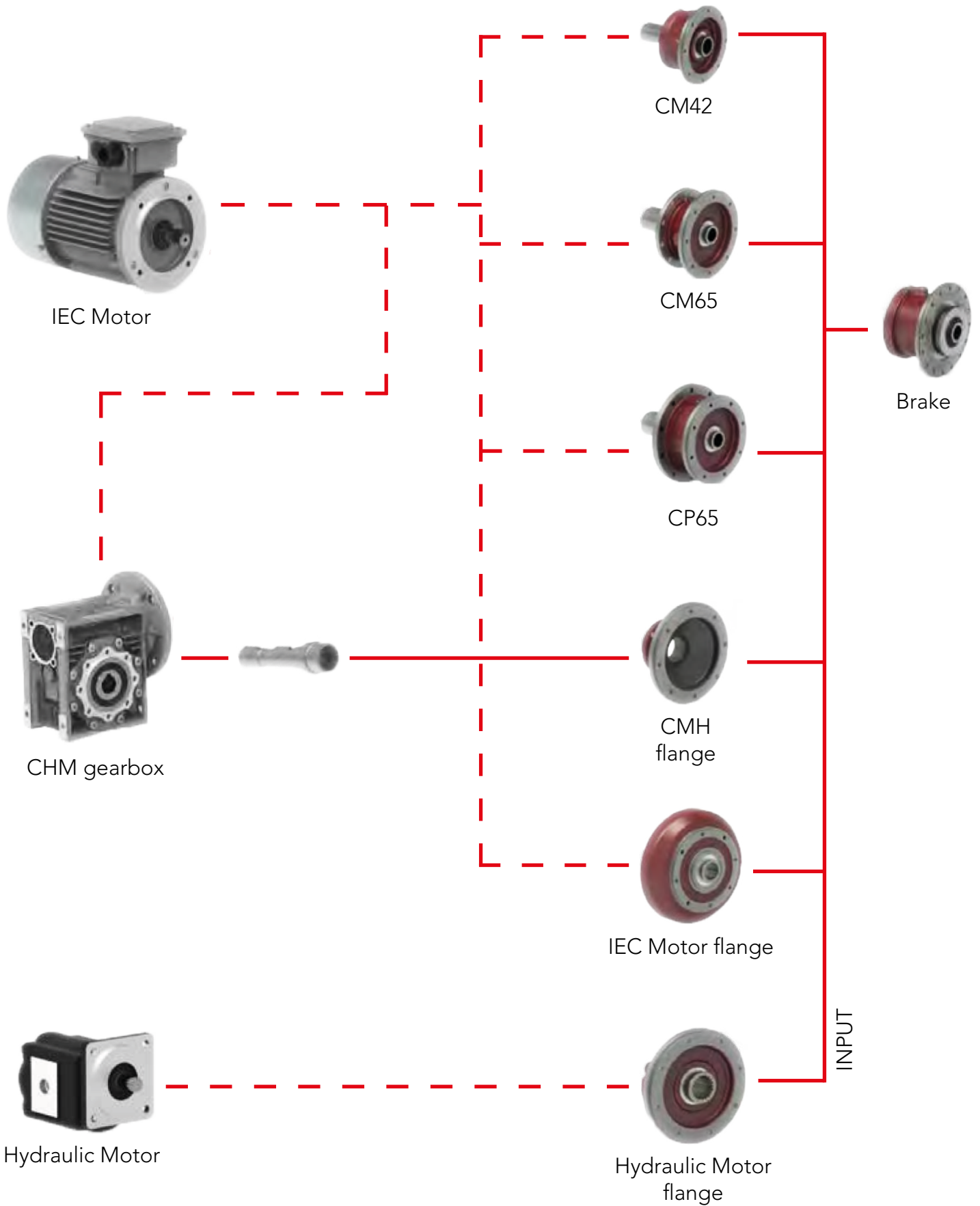

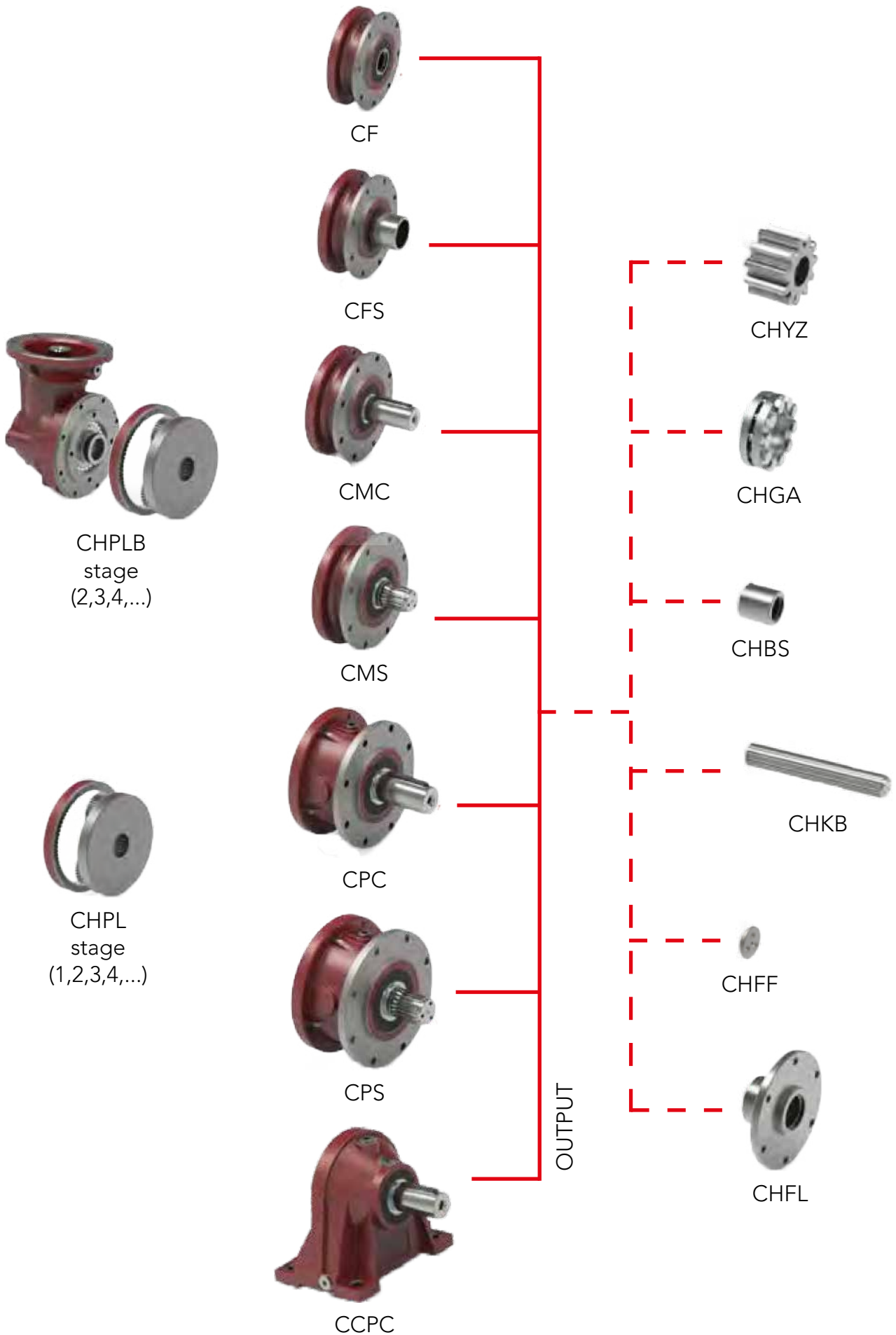

CARATTERISTICHE TECNICHE · TECHNICAL FEATURES

Al fine di utilizzare al meglio il presente catalogo come strumento professionale, vengono di seguito riportate le definizioni dei parametri caratteristici che saranno utilizzati:

Rapporto di trasmissione**i**

Indica il rapporto tra la velocità di rotazione in ingresso n_1 e la velocità di rotazione n_2 ottenuta in uscita dal gruppo riduttore.

Velocità massima in entrata **n_{1max} [rpm]**

Indica la massima velocità di rotazione consentita in ingresso al riduttore, considerando il funzionamento intermittente e non continuo del gruppo.

Per applicazioni ove richiesto un funzionamento continuo del riduttore si prega di contattare il Servizio Tecnico CHIARAVALLI.

Coppia nominale in uscita **T_{2n} [Nm]**

Indica la coppia trasmessa dal riduttore calcolata secondo i limiti della norma internazionale ISO 6336 in condizioni di $F_s=1$.

Potenza nominale in ingresso **P_{1n} [kW]**

Indica la potenza meccanica installabile sul riduttore secondo i limiti della norma internazionale ISO 6336. Valori riferiti a 1400 rpm $F_s=1$.

Rendimento **μ [%]**

Indica il rendimento del riduttore tenendo conto delle perdite energetiche che si hanno durante il suo funzionamento. Mediamente il rendimento dei riduttori epicicloidali lineari (CHPL) è dello 0.97 - 0.98 % per stadio di riduzione; è leggermente inferiore nel caso di stadi di riduzione angolari (CHPLB).

Questo valore viene influenzato anche da altri fattori come l'alta velocità, la coppia, il rapporto di riduzione e la lubrificazione

Here we are going to describe the characteristics and information necessary in order to use this catalogue in the most suitable way for any kind of final usage of our gear units in any market or professional fields:

Reduction ratio**i**

Provide the ratio between input rotation speed n_1 and the output one n_2 in our planetary gearboxes.

Maximum input speed **n_{1max} [rpm]**

This indicates the maximum input speed rotation allowed, considering a non-continuous use.

Please contact CHIARAVALLI Technical dept. in case of continuous duty.

Nominal output torque **T_{2n} [Nm]**

This indicates the output torque values calculated according international ISO 6336 in $F_s=1$ conditions

Input nominal power **P_{1n} [kW]**

This indicates the mechanical power assembling on our planetary gear boxes according international ISO 6336. Ref. values to 1400 rpm $F_s=1$

Efficiency **μ [%]**

Give the value of the reducer efficiency considering the energy losses due to its normal usage. CHPL efficiency of our planetary gearboxes is about 0.97 - 0.98% for every reduction stage, while on CHPLB is a little less.

Note these values may be influenced by several factors as high speed, the torque, the ratio and the lubrication.



CARATTERISTICHE TECNICHE · TECHNICAL FEATURES

Coppia Massima T_2 max [Nm]

È il valore massimo di coppia che il riduttore può trasmettere per breve tempo senza che si verifichino danneggiamenti ai suoi componenti interni ed alla sua struttura. Tale valore deve essere considerato come una coppia massima dovuta a picchi o spunti di avviamento e mai come coppia di lavoro; il valore T_2 max deve inoltre essere opportunamente valutato in quegli azionamenti che comportano un elevato numero di avviamenti o inversioni. Il valore T_2 max è indicato nelle schede tecniche di prodotto.

Temperatura di funzionamento**t [°C]**

La temperatura dell'olio deve essere compresa tra -15° e +90°C.

Per temperature di funzionamento al di fuori di questo intervallo si consigliano tenute in materiali specifici e oli adeguati fornibili su richiesta.

Contattare il Servizio Tecnico CHIARAVALLI.

Potenza termica**P_t [kW]**

Indica la massima potenza dissipabile termicamente dal riduttore affinché la temperatura dell'olio e delle sue tenute rimanga entro i limiti consentiti.

Tale potenza si intende come dissipabile per convezione naturale dal corpo del riduttore stesso nell'ambiente in cui esso lavora e con lubrificazione interna a sbattimento.

I valori definiti per le potenze termiche, vengono considerati in condizioni di:

- Temperatura massima olio 90°C
- Olio ISO VG 150
- Temperatura ambiente 20°C.
- Posizione di montaggio orizzontale
- Servizio continuo
- $n_1=1400$ rpm

Per via della loro geometria i riduttori con uscita CCPC (uscita con piedi, fino alla taglia 16000), possono sopportare un incremento della potenza termica dal 10 al 15%.

Nel caso in cui la potenza installata superi quella termica sarà necessario l'utilizzo di un sistema di raffreddamento ausiliario in grado di dissipare la potenza termica in eccesso. Contattare il Servizio Tecnico CHIARAVALLI.

Materiali

Cassa Ghisa sferoidale
Ingranaggi 21NiCrMo2 temprati e cementati Trattamento 58/60 HRC

Maximum Torque T_2 max [Nm]

This is the maximum output torque that the drive can transmit over a brief time interval without damaging its internal components and structure. This value must be considered as the maximum output torque owing to working or start-up peaks and never as the continuous working torque. T_2 max must also be carefully evaluated in those applications with a high number of start-ups or reversals.

The T_2 max value is shown on the single product Technical cards.

Usage temperature**t [°C]**

Oil temperature must be among -15° and +90°C.

For any different temperature usage, we warmly recommend particular/specific oil seals and oils available under request.

Please contact CHIARAVALLI Technical dept. for any info you might need.

Thermal power rating**P_t [kW]**

Indication of the maximum power that can be dissipated by the gearbox keeping oil and oil seals under the allowed limits.

This power can be dissipated for natural convection from the housing gearbox to the ambience with normal turbulence lubrication.

The values here described of thermic power must be considered according:

- Oil max temperature 90°C
- Oil ISO VG 150
- Outside temperature 20°C
- Horizontal mounting position
- Continuous duty
- $n_1=1400$ rpm

Due to their geometry CCPC reducers (foot mounted up to size 16000) allow a thermal power increase of about 10 to 15%.

In case the installed power overcomes the thermal one, an external cooled system is necessary in order to dissipate the extra heat. Please contact CHIARAVALLI Technical dept. for any info you might need.

Materials

Spheroidal Cast Iron
Gears 21NiCrMo2 case hardened and tempered Hardness 58/60 HRC

CARATTERISTICHE TECNICHE · TECHNICAL FEATURES

Fattore di servizio

Fs

Indica il coefficiente di moltiplicazione della coppia o potenza in funzione delle condizioni di lavoro (carichi, avviamenti, ore di funzionamento, tipologia di motorizzazione e tipologia di applicazione).

Il fattore di servizio F_s può considerarsi influenzato principalmente da tre fattori:

- tipo di carico: U - M - H
- ore di lavoro giornaliere: h/day
- frequenza oraria avviamenti: na/h

Service factor

Fs

This is a multiplication coefficient that indicates how much the torque and the power may be increased according any different working conditions.

Service Factor F_s may be influence by mainly 3 factors:

- type of load: U - M - H
- daily working hours: h/day
- hour frequency starter: na/h

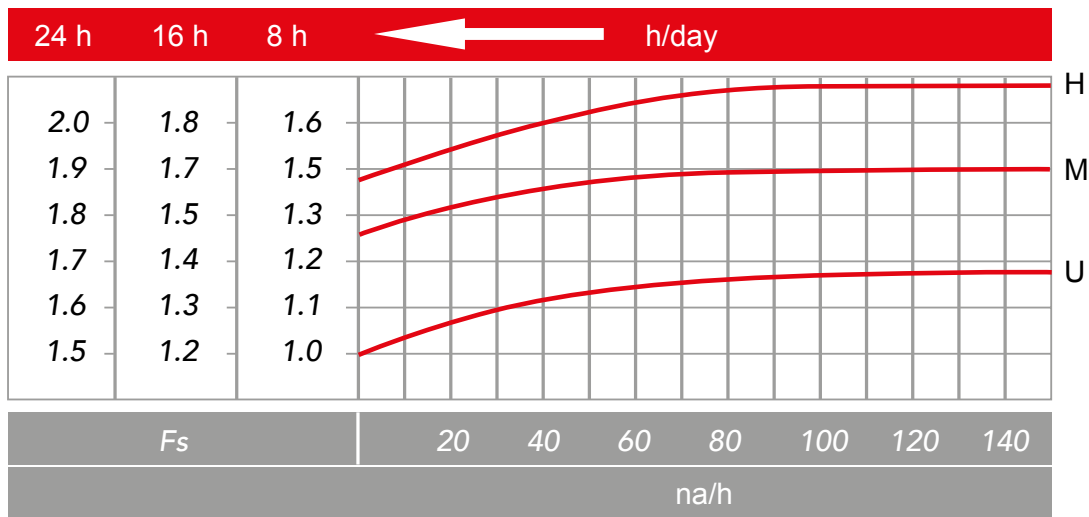

U: Trasportatori a nastro per pesi leggeri
Pompe centrifughe
Elevatori
Imbottigliatrici

U: Conveyor belts for light weights
Centrifugal pumps
Lifts
Bottling machines

M: Trasportatori per materiali pesanti
Macchine imballaggio
Pompe a ingranaggi

M: Conveyor belts for heavy weights
Packing machines
Gear pumps

H: Mescolatori
Elevatori a tazze
Macchine utensili
Macchine per laterizi
Vibratori

H: Mixers
Bucket elevators
Tooling machines
Machinery for bricks
Vibrators

**CARATTERISTICHE TECNICHE · TECHNICAL FEATURES****Scelta del riduttore**

Il riduttore di velocità opera tra la parte motore, adibita alla generazione della coppia motrice, e la parte macchina che genera coppia resistente sul riduttore.

Per selezionare correttamente il riduttore occorrerà conoscere tipologie e caratteristiche del motore installato, potenza erogata, coppia erogata e velocità di funzionamento.

Per quanto concerne il lato macchina, occorrerà conoscere la tipologia di servizio, potenza/coppia assorbita, velocità di rotazione e ciclo di lavoro.

Con tali informazioni si vanno a definire:

- Coppia di lavoro T [Nm]
- Potenza installata P [kW]
- Rapporto di trasmissione i
- Carichi sull'albero in uscita e in entrata al riduttore F_r ; F_a [N]

In seguito si andranno a verificare i parametri che caratterizzano il riduttore.

- Coppia di lavoro, tenendo conto del fattore di servizio F_s $T \cdot F_s \leq T_{2n}$
- Potenza installata, tenendo conto del fattore di servizio F_s $P \cdot F_s \leq P_{1n}$
- Velocità in ingresso al riduttore $n_1 < n_{1max}$
- Potenza da trasmettere $< P_t$
(se in servizio continuo)
- Carichi sull'albero in uscita e in entrata al riduttore F_r ; F_a [N]
- Condizioni di lubrificazione e temperatura ambiente

Planetary gearboxes selection

The unit works between the input motor part, that creates the torque, and the final equipment.

To select the more suitable gearbox in any final usage, it is necessary to have the type and the characteristics of the mounted motor, the power, the torque and the working speed.

Concerning the driven machine it is necessary to know the type of operation, power and torque requested, speed and duty.

According with these informations we define together:

- Working torque T [Nm]
- Mounted power P [kW]
- Ratio i
- Radial and axial loads on input and output shafts F_r ; F_a [N]

Consequently the gearbox parameters will be defined

- Working torque considering F_s where $T \cdot F_s \leq T_{2n}$
- Mounted power considering F_s where $P \cdot F_s \leq P_{1n}$
- Input speed $n_1 < n_{1max}$
- Requested Power $< P_t$
(for continuous duty)
- Radial and axial loads on input and output shafts F_r ; F_a [N]
- Lubrication and room temperature

INSTALLAZIONE E MANUTENZIONE · INSTALLATION AND MAINTENANCE

Installazione e manutenzione

Per ottenere le migliori prestazioni dal riduttore, si consiglia di provvedere ad un adeguato rodaggio dello stesso incrementando la potenza gradualmente nelle prime ore di funzionamento.

In questa fase un aumento delle temperature è da considerarsi nella norma. In caso di funzionamento difettoso, rumorosità, perdite olio etc. arrestare immediatamente il riduttore e, dove possibile, rimuovere la causa e contattare il Servizio Tecnico CHIARAVALLI.

Prima e durante l'installazione effettuare i seguenti controlli:

- I dati riportati sulla targhetta identificativa devono corrispondere al riduttore ordinato.
- Il livello dell'olio dovrà corrispondere alla quantità prevista per la posizione di montaggio richiesta (vedi paragrafo "Lubrificazione").
- Il fissaggio del riduttore deve avvenire su superfici piane e sufficientemente rigide in modo da evitare qualsiasi vibrazione.
- Il riduttore e l'asse della macchina da movimentare devono essere in perfetto allineamento.
- In caso si prevedano urti, sovraccarichi o blocchi della macchina il cliente dovrà provvedere all'installazione di limitatori, giunti, salvamotori etc.
- Gli accoppiamenti con pignoni, giunti, pulegge ed altri organi devono essere fatti previa pulizia delle parti ed evitando urti nel montaggio poiché questo potrebbe danneggiare i cuscinetti ed altre parti interne.
- Nel caso il motore sia di fornitura del cliente questi dovrà accertarsi che le tolleranze di flangia ed albero corrispondano ad una classe "normale", i nostri motori rispondono a questa esigenza.
- Verificare che le viti di fissaggio del riduttore e dei relativi accessori siano correttamente serrate.
- Adottare gli opportuni accorgimenti per proteggere i gruppi da eventuali agenti atmosferici aggressivi.
- Dove previsto proteggere le parti rotanti da possibili contatti con gli operatori.
- Nel caso i riduttori vengano verniciati proteggere gli anelli di tenuta ed i piani lavorati.

Nel caso di applicazioni in cui sia richiesto l'utilizzo di motori con massa superiore ai 100 kg, si consiglia di contattare il Servizio Tecnico CHIARAVALLI.

Nel caso di lunga conservazione a magazzino, superiore ai tre mesi, si consiglia di proteggere alberi e piani lavorati con antiossidanti e di ingrassare gli anelli di tenuta.

Run-in and maintenance

In order to achieve the best gearbox performances, during the run-in, we warmly recommend to increase the power step by step and strictly control the temperature.

During this period an increase of temperature must be considered normal.

In any case of defected drive, noise, oil losses please immediately stop the gear box unit, if possible remove the problem and contact CHIARAVALLI Technical department.

Before and during the first run-in please check:

- The data shown on the identification nameplate must correspond to the gearbox ordered.
- The oil level depends on the mounting position requested (see section LUBRICATION).
- The gearbox must be on a flat surface that is sufficiently rigid in order to avoid any vibration.
- The gearbox and the axis of the machine to be driven must be perfectly aligned.
- In the event that knocks, overloading or blockage of the machine are foreseen, the customer must install a limit device, couplings overload cut-out etc.
- Coupling with pinions, joints, pulleys and other parts must be done after the parts have been cleaned and knocks should be avoided while assembling as they could damage the bearings and other internal parts.
- In the event that the motor is supplied by the customer, he must check that the flange and shaft tolerances correspond to a "normal" class; our motors satisfy this requirement.
- Verify that the fixing screws for the gear and the related accessories are correctly tightened.
- Take suitable measures to protect the groups from any aggressive atmospheric agents.
- Where foreseen, protect rotating parts from any possible contact with the operators.
- If the gearboxes are painted, protect the oil seals and the machined surface.

As the application requires the assembling of a motor over 100 kg, we suggest to contact CHIARAVALLI Technical department for further information.

In case of long storage in warehouse, for example more than 3 months, please protect the shafts and the machined surfaces using antioxidants and grease the oil seals.



INSTALLAZIONE E MANUTENZIONE · INSTALLATION AND MAINTENANCE

Gruppi con fissaggio a flangia/piedi

Uscite maschio tipo CMS - CMC - CPS - CPC

E' necessario utilizzare sempre tutti i centraggi previsti sugli alberi scanalati, specie per applicazioni in cui sono adottati pignoni dentati.

Per le uscite maschio si consiglia di adottare entrambi i centraggi delle flange d'attacco, nel caso in cui i carichi radiali superino del 50% i valori indicati nei relativi grafici (vedere singole schede grandezza riduttore).

Nel caso di applicazioni gravose con forti sollecitazioni sia sull'albero in ingresso che sull'albero in uscita è consigliabile contattare il Servizio Tecnico CHIARAVALLI.

Uscite maschio con piedi CCPC

Per le uscite con piedi è necessario controllare i piani della struttura d'appoggio in modo da creare un perfetto allineamento tra il riduttore e l'albero da movimentare.

In caso di difficoltà si consiglia di effettuare il collegamento tramite un giunto elastico. Una volta installato il riduttore verificare che non ci siano vibrazioni anomale.

Uscite femmina tipo CF

Per le uscite femmina scanalate è necessario verificare in modo accurato la coassialità/ortogonalità con l'albero di trasmissione. Per via della loro struttura queste tipologie di uscite non sono adatte a sopportare carichi radiali.

Uscite con calettatore a montaggio pendolare CFS

Tale uscita necessita l'adozione di un opportuno calettatore (fornibile su richiesta) per collegare l'albero cavo del riduttore all'albero maschio della macchina.

Per tale accoppiamento sgrassare accuratamente le superfici interessate, procedere all'avvitamento delle viti del calettatore in modo graduale e una alla volta.

E' importante verificare che l'albero maschio da calettare rispetti le dimensioni e le tolleranze riportate nelle relative pagine dimensionali.

Per l'installazione dell'uscita CFS è possibile utilizzare il braccio di reazione come indicato nelle relative schede tecniche; si consiglia l'utilizzo di bracci di reazione con elementi antivibranti.

Nel caso di applicazioni in cui sia richiesto l'utilizzo di motorizzazioni particolarmente pesanti o si utilizzino cinghie sul lato entrata, si consiglia di contattare il Servizio Tecnico CHIARAVALLI.

Unit with flange/feet clamping

Male output CMS - CMC - CPS - CPC

When tooth pinions are mounted, the spigots on the splined output shafts must be used.

For these kind of units, when the radial loads are 50% higher than values indicate in the tables (please check tables in the following pages), we warmly suggest to use both spigots of the flanges.

In case of heavy applications, contact CHIARAVALLI Technical department for further information.

Male output with feet CCPC

For these gearboxes please check the properly aligned between the gear unit and the operating shaft, use a flexible coupling in case of difficulties, finally please check the vibrations.

Female output CF

Carefully check the gearbox concentricity and perpendicularity, this must be in line with the axis of the driven shaft. Due to this characteristic CF type is not suitable for radial load.

Shaft mounted output with locking element type CFS

For this type it is necessary to use a suitable locking element (available on request) to connect the gearbox hollow shaft with the operating shaft. In this case properly degrease the internal surface, then proceed tightening the locking screws in a gradual, uniform and continuous sequence one by one.

Check the tolerances and the dimensions provided on each drawing of the operating shaft.

CFS output can be mounted with a torque arm as indicate on the technical tables, we suggest using torque arms with antivibration rubber elements.

In case of heavy applications or with belts on the input side, please contact CHIARAVALLI Technical department for further information.

LUBRIFICAZIONE · LUBRICATION

La lubrificazione degli organi interni è indispensabile per garantire il buon funzionamento e la corretta durata del riduttore CHIARAVALLI.

Si consiglia pertanto di effettuare le seguenti verifiche:

- **POSIZIONE ORIZZONTALE:**
indipendentemente dalla versione lineare o angolare è importante verificare che l'olio raggiunga la mezzeria del riduttore.
- **POSIZIONE VERTICALE:**
in questa posizione è molto importante verificare che il cuscinetto e l'anello di tenuta che si trovano nel punto superiore del gruppo siano costantemente a contatto con l'olio.
E' consigliato installare il vaso di espansione (fornibile su richiesta) in modo da prevenire eventuali espansioni dell'olio con l'aumentare della temperatura. In caso di impossibilità di installazione del vaso consigliamo l'utilizzo di appositi raccordi e prolunghe in modo da garantire il corretto livello dell'olio (verificare sempre l'assenza di bolle d'aria in fase di riempimento d'olio).

Accertarsi che il riduttore abbia i tappi montati nei punti coerenti alla relativa posizione di montaggio come successivamente indicato.

Durante il funzionamento la superficie esterna del riduttore deve restare sotto i 90°C.

In caso di applicazioni con elevate temperature contattare il Servizio Tecnico CHIARAVALLI.

Cambio olio

Si consiglia di effettuare il primo cambio dell'olio dopo 100 h di funzionamento.

Per quelli successivi considerare circa 2000 h di utilizzo o comunque almeno una volta all'anno.

Durante la vita del riduttore, controllare visivamente che non vi siano perdite o trafilamenti di olio.

Se l'olio scende al di sotto del livello minimo, effettuare un rabbocco con il medesimo olio precedentemente utilizzato.

E' importante non mischiare lubrificanti con caratteristiche differenti.

E' opportuno eseguire il cambio dell'olio quando il riduttore è ancora caldo in modo da evitare possibili depositi e sedimenti solidi all'interno del corpo del riduttore stesso. Si consiglia inoltre, una volta svuotato il riduttore dall'olio esausto, di effettuare un lavaggio dell'interno con un apposito detergente indicato dal fornitore del lubrificante che si andrà ad adottare.

In order to make the CHIARAVALLI planetary gearboxes run efficiently we recommend a correct lubrication following these simple suggestions:

- **HORIZONTAL POSITION:**
no matter if linear or angular version, the oil must reach the half of the gearbox.
- **VERTICAL POSITION:**
*In this position the bearings and the oil seals must be continuously in contact with oil.
We suggest to use an expansion tank (available on request) to avoid any oil spread at the increase of temperature.
In some cases the assembling of the tank is not allowed, so we suggest to use suitable extensions and pipes to guarantee the correct oil level (please check any possible air bubble while filling the oil).*

Check the correct position of the plugs according the assembling position as we indicate beyond.

Maximum external surface gearbox temperature must be under 90°C.

Please contact CHIARAVALLI Technical department for any different case.

Oil changes

We suggest the first change after 100h of work, then please consider 2000 running hours or at least once per year.

During the gearbox life periodically check the oil level and possible oil leakages.

Please fill extra oil in case of lack or under minimum level without changing the type of oil.

Do never mix the type of oil.

To avoid sediment change the oil when the reducer is still warm, clean the internal parts using only the correct and recommend detergent after empty the reducer.



LUBRIFICAZIONE · LUBRICATION

Vaso di espansione

Per i gruppi montati in posizione verticale (lineari CHPL o angolari CHPLB) e in posizione orizzontale con la coppia conica rivolta verso l'alto, si consiglia l'utilizzo del vaso di espansione. Il vaso va posizionato al di sopra del punto più alto del riduttore ed ha il compito di contenere eventuali espansioni dell'olio all'aumentare della temperatura e garantire un rabbocco sicuro. Tale accessorio può essere fornito su richiesta.

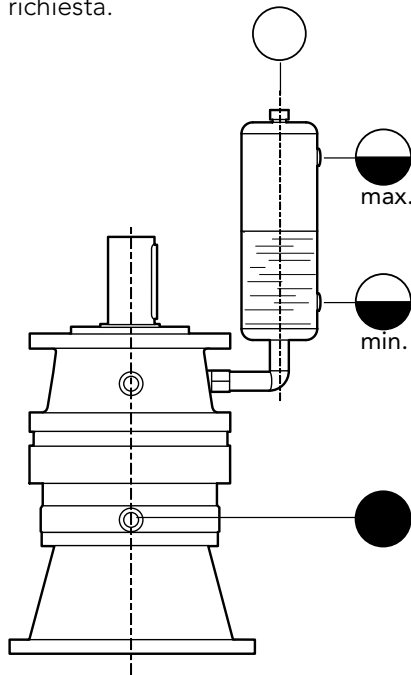

Riduttore assiale verticale con ingresso inferiore.
Axial gearbox vertical position with lower input.

Expansion tank

Use the expansion tank for the CHPL and CHPLB groups mounting in vertical position and in horizontal position when the bevel gear is upside assembled. Put the tank on the gearbox higher point to control any oil spread due to temperature increasing and fill the reducer properly. This item is available on request.

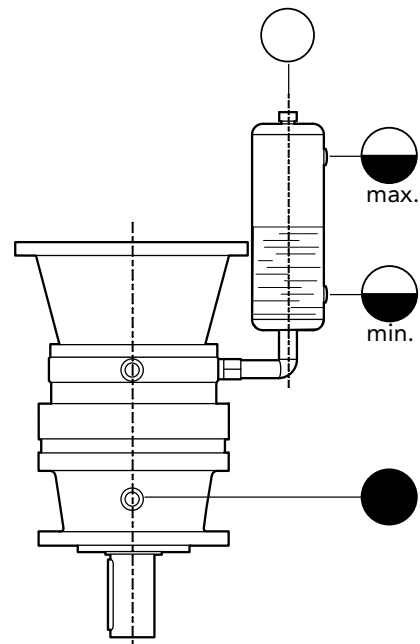

Riduttore assiale verticale con ingresso superiore.
Axial gearbox vertical position with upper input.



-  Tappo di carico/sfiato olio
Oil filling/vent plug
-  Tappo di livello olio
Oil level plug
-  Tappo di scarico olio (magnetico)
Oil drain plug (magnetic)

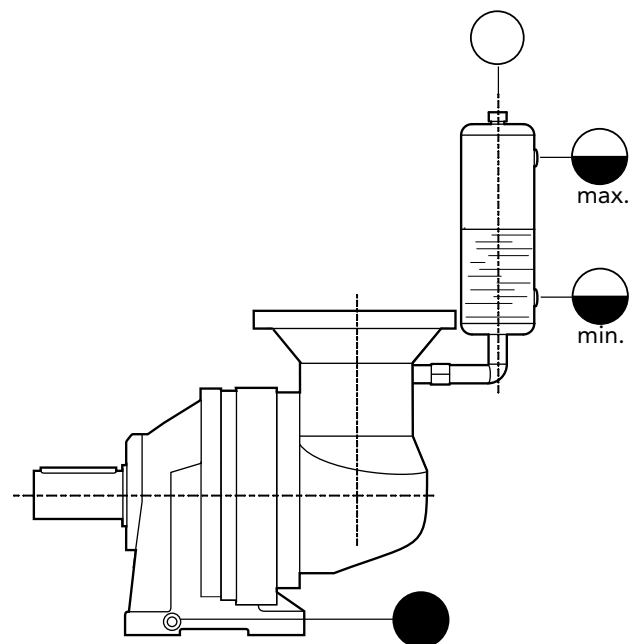

Riduttore angolare orizzontale con ingresso superiore.
Bevel gearbox horizontal position with upper input.

LUBRIFICAZIONE · LUBRICATION

Smaltimento olio esausto

In fase di smaltimento degli oli esausti, è obbligatorio usare tutte le cautele per non inquinare suolo, aria e acqua. L'olio esausto, non deve essere inquinato da altre sostanze estranee e deve obbligatoriamente essere smaltito in appositi centri autorizzati, il tutto nel rispetto delle normative vigenti.

Lubrificante

CHIARAVALLI consiglia l'uso di oli per ingranaggi con additivi EP (elevate pressioni) ed antischiuma.

Per applicazioni ad elevate temperature, si consiglia l'utilizzo di oli sintetici a base polialfaolefina (PAO) o a base poliglicole (PG).

Nella tabella successiva suggeriamo alcuni oli idonei alla lubrificazione in funzione della temperatura d'utilizzo.

Exhausted oil disposing





According to the local environmental protection laws and regulations adopt precaution necessary to avoid to pollute ground, air and water.

The exhausted oil must be not contaminated by any other substance and should be sent to specialised companies for recycling when possible.

Lubricant

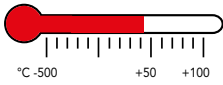
CHIARAVALLI technical dept. suggests the use of EP oil with additives and antifoam. In case of high temperature please use PAO synthetic or PG oils.

In the following table check some useful oils according to the working temperature.

	Temperatura ambiente / Ambient temperature [°C]								
	Olio minerale Mineral Oil			Olio sintetico Polialfaolefina (PAO) Poly-alpha-Olefin Synthetic Oil (PAO)			Olio sintetico Poliglicoli (PG) Poly-glycol Synthetic Oil (PG)		
	-10 ÷ +30+	10 ÷ +45+	30 ÷ +60-	20 ÷ +60-			20 ÷ +60		
ISO 34481	SO VG 150I	SO VG 220I	SO VG 320I	SO VG 150I	SO VG 220I	SO VG 320I	SO VG 150I	SO VG 220I	SO VG 320I
 AGIP	Blasia 150	Blasia 220	Blasia 320	-	Blasia SX 220	Blasia SX 320	Blasia S 150	Blasia S 220	Blasia S 320
 ESSO	Spartan EP 150	Spartan EP 220	Spartan EP 320	Spartan S EP 150	Spartan S EP 220	Spartan S EP 320	Glycolube 150	Glycolube 220	Glycolube 320
 MOBIL	Mobilgear XMP 150	Mobilgear XMP 220	Mobilgear XMP 320	Mobilgear SHC XMP 150	Mobilgear SHC XMP 220	Mobilgear SHC XMP 320	Glygoyle 22	Glygoyle 30	Glygoyle HE 320
 SHELL	Omala S2G 150	Omala S2G 220	Omala S2G 320	Omala S4GX 150	Omala S4GX 220	Omala S4GX 320	Omala S4WE 150	Omala S4WE 220	Omala S4WE 320



La viscosità aumenta al diminuire della temperatura (diventa più denso) e diminuisce all'aumentare delle temperatura (diventa più fluido).
The viscosity of the lubricant decrease as the temperature rises and increase as the temperature drops.



LUBRIFICAZIONE · LUBRICATION

Quantità lubrificante











I quantitativi di olio di seguito riportati sono indicativi e soggetti a variazioni in funzione della configurazione del riduttore. Indipendentemente dai quantitativi di seguito riportati, controllare sempre visivamente che l'olio raggiunga il livello corretto come precedentemente indicato.

Lubricant quantity

The data in the table here below are indicative and may change according the gearbox mounting position.





















Please always check the oil level following the previous suggestions.

CHPL riduttori assiali | axial gearboxes 1000 ÷ 10000

		Tipo di uscita / Output type									
		CMS - CMC		CPS - CPC		CF		CFS		CCPC	
											
CHPL	1001	0,5	0,9	0,8	1	0,5	0,9	0,5	0,9	1,4	1,8
	1002	0,7	1,2	0,8	1,5	0,7	1,2	0,7	1,2	1,6	2,1
	1003	1	1,7	1	1,9	1	1,7	1	1,7	1,8	2,5
	1004	1,3	2,2	1,2	2,3	1,3	2,2	1,3	2,2	2,4	3
CHPL	1601	0,5	1	0,6	1	0,5	1	0,5	1	1,5	1,8
	1602	0,7	1,3	0,8	1,2	0,7	1,3	1	1,3	1,9	2,1
	1603	1	1,8	1,4	1,9	1	1,8	1,4	1,8	2	2,6
	1604	1,3	2,2	1,5	2,3	1,3	2,2	1,3	2,2	2,1	3,1
CHPL	2501	1,3	1,9	1,2	2,3	0,9	1,5	1,1	1,9	3,8	4,9
	2502	1,9	2,3	2	2,7	1	1,9	1,3	2,3	4,1	5,3
	2503	1,9	2,8	2	3,1	1,2	2,3	1,6	2,8	4,1	5,8
	2504	2,3	3,2	1,9	3,6	1,4	2,7	1,8	3,2	4,3	6,2
CHPL	5001	1,1	1,9	1,5	2,1	0,8	1,4	1,1	1,4	3,8	4,7
	5002	1,7	2,3	1,5	2,4	1,4	1,9	1,4	1,9	4	5,2
	5003	1,6	2,8	1,7	2,75	1,3	2,3	1,6	2,3	4,4	6
	5004	2,3	3,1	1,9	3,9	1,6	2,7	1,9	2,7	4,3	6,1
CHPL	7001	-	-	2	3,5	1,7	3	2	3,5	7,4	9,7
	7002	-	-	2,4	4,4	2,4	3,8	2,4	4,4	8,5	10,6
	7003	-	-	3,1	4,5	3	4,3	2,7	4,8	8,8	10,8
	7004	-	-	3,5	5,2	2,6	4,7	2,9	5,2	9	11,4
CHPL	10001	2,9	5,3	-	-	1,7	3,1	2,9	5,3	9,5	12,7
	10002	3,2	6,2	-	-	2,1	3,9	3,2	5,9	10	13,3
	10003	4	7	-	-	2,4	4,4	3,5	6,5	10,2	13,9
	10004	3,7	6,9	-	-	2,6	4,8	3,7	6,9	11	14,3

QUANTITA' LUBRIFICANTE · LUBRICATION QUANTITY











CHPL riduttori assiali | axial gearboxes 16000 ÷ 35000

		Tipo di uscita / Output type									
		CMS - CMC		CPS - CPC		CF		CFS		CCPC	
											
											
		[1]	[1]	[1]	[1]	[1]	[1]	[1]	[1]	[1]	[1]
CHPL	16001	3,1	5,8	3,6	6,7	2,1	3,8	3,1	5,8	9,7	12,9
	16002	3,4	6,3	3,9	7,3	2,6	4,4	3,4	6,3	10	13,6
	16003	3,6	6,8	4,2	7,9	2,8	5	3,8	6,8	10,3	14,1
	16004	4	7,3	4,4	8,3	3	5,4	4	7,2	10,6	14,5
CHPL	18002	4	7,3	4,6	8,5	3,1	5,6	4	7,3	10,8	14,7
	18003	4,4	8,2	5	9,3	3,6	6,4	4,4	8,2	11,2	15,5
	18004	4,9	8,6	5,3	9,7	3,9	6,8	4,8	8,6	11,5	16
CHPL	25001	7,6	14,2	-	-	5,9	10,7	5,7	10,5	7,6	14,2
	25002	6,5	12,6	-	-	5,4	8,2	4,6	8,4	6,5	12,2
	25003	7	13	-	-	7	9,7	5	9,2	7	13
	25004	9,5	13,4	-	-	7,2	10,1	5,2	9,6	7,2	13,4
CHPL	30002	7,5	13,9	-	-	5,6	10,4	5,2	9,8	7,5	13,9
	30003	8	14,4	-	-	6	11,1	5,6	10,6	7,7	14,4
	30004	11	14,9	-	-	8,5	11,6	5,8	11,1	8	14,9
CHPL	35001	7,5	13,7	-	-	5,4	9,9	5,1	9,2	7,5	13,7
	35002	8,5	13,3	-	-	5,2	9,6	5	9	7,3	13,3
	35003	7,6	14	-	-	5,6	10,3	5,6	10,1	7,6	14
	35004	7,9	14,5	-	-	5,9	10,8	5,7	10,3	7,9	14,5



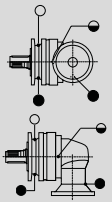
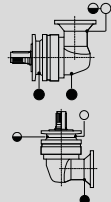
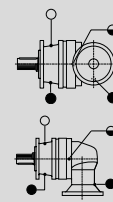
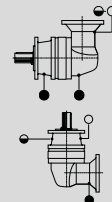
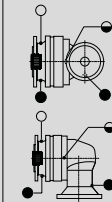
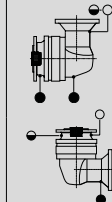
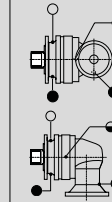
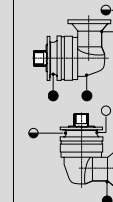
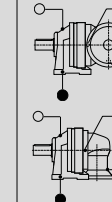
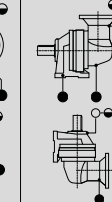

QUANTITA' LUBRIFICANTE · LUBRICATION QUANTITY

CHPL riduttori assiali | axial gearboxes 1000 ÷ 35000

											
		CMS - CMC		CPS - CPC		CF		CFS		CCPC	
		Tpo di uscita / Output type									
											
CHPLB	1002	1,2	1,9	1,3	2	1,2	1,9	1,2	1,9	2	2,8
	1003	1,4	2,2	1,5	2,5	1,4	2,2	1,4	2,2	2,2	3,1
	1004	1,7	2,7	1,7	2,9	1,7	2,7	1,7	2,7	2,5	3,6
CHPLB	1602	1,2	2	1,3	2,1	1,2	2	1,2	2	2	2,8
	1603	1,4	2,3	1,5	2,4	1,4	2,3	1,4	2,3	2,2	3,2
	1604	1,7	2,8	1,8	2,9	1,7	2,8	1,7	2,8	2,5	3,7
CHPLB	2502	1,8	2,9	2	3,3	1,6	2,5	1,8	2,9	4,6	5,8
	2503	1,9	3,4	2,1	3,7	1,9	2,9	2,2	3,3	4,7	6,5
	2504	2,3	3,8	2,4	4,1	1,9	3,3	2,3	3,8	4,8	6,8
CHPLB	5002	2,9	5,2	3	5,4	2,6	4,7	2,9	5,2	5,1	7,6
	5003	2,1	3,3	2,2	3,6	1,8	2,9	2,1	3,3	4,5	6,1
	5004	2,3	3,7	2,4	5	2	3,3	2,3	3,7	4,7	6,5
CHPLB	7002	-	-	3,8	6,8	3,5	6,3	3,8	6,8	9	12,7
	7003	-	-	3,1	5,4	2,8	4,8	3,1	5,4	8,3	11,3
	7004	-	-	4	5,8	3,1	5,3	3,4	5,8	8,7	12
CHPLB	10002	4,7	8,6	-	-	3,5	6,4	4,7	8,6	10,8	15,1
	10003	5	9,2	-	-	3,9	7,2	5	9,2	11,4	16,2
	10004	4,2	7,5	-	-	3,1	5,4	7,2	7,5	10,7	14,8
CHPLB	16002	4,9	9,1	5,4	10	3,9	7,1	4,9	9,1	10,9	15,3
	16003	5,2	9,6	5,7	10,6	4,4	7,7	5,2	9,6	11,5	16,5
	16004	4,5	9	4,9	8,9	3,5	6	4,5	7,8	10,9	15
CHPLB	18002	8,6	15,6	9,2	16,6	7,7	13,7	8,6	15,6	15,3	22,7
	18003	5,8	10,6	6,4	11,8	4,9	8,9	5,8	10,6	11,9	16,9
	18004	6,2	11,5	6,8	12,6	7,2	9,7	6,2	11,5	12,8	18,7
CHPLB	25002	10	18,5	-	-	8,1	14,9	8	14,7	10	18,5
	25003	8,3	15,5	-	-	11,5	11,5	6,4	11,7	8,3	15,5
	25004	8,8	15,5	-	-	13	13	6,8	12,5	8,8	15,5
CHPLB	30003	12,6	23,7	-	-	11,2	20,4	11	19,9	12,6	23,7
	30004	9,5	17,7	-	-	7,8	14,4	7,4	13,9	9,5	17,7
CHPLB	35002	9,7	17,7	-	-	8	14,5	7,7	14	9,7	17,7
	35003	12,7	23,4	-	-	10,7	19,5	10,5	19,3	12,7	23,4
	35004	12,1	17,3	-	-	7,4	13,6	7,4	13,4	9,4	17,7

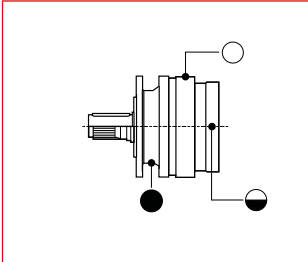
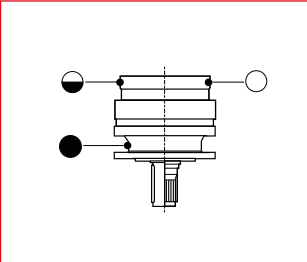
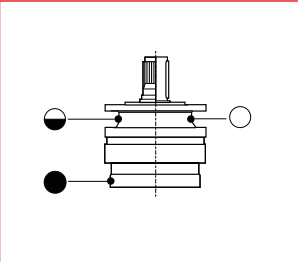
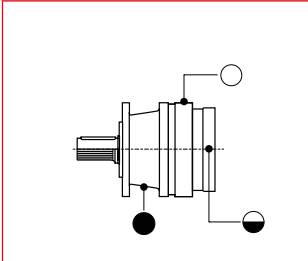
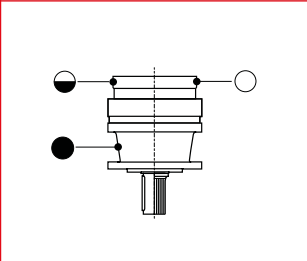
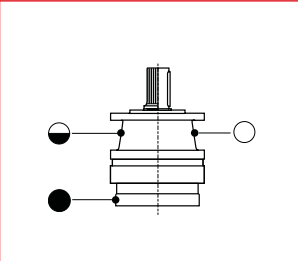
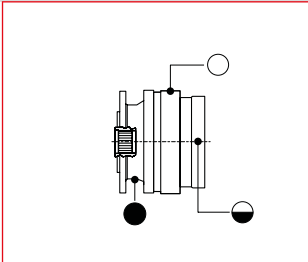
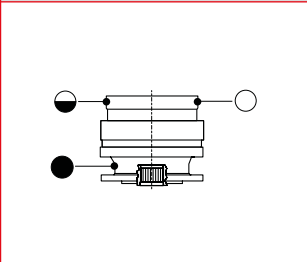
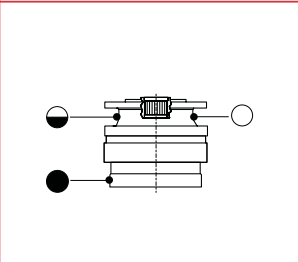
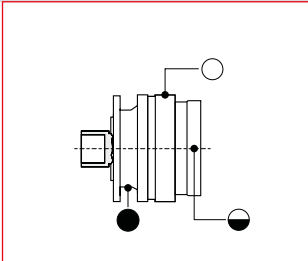
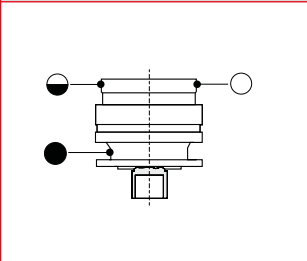
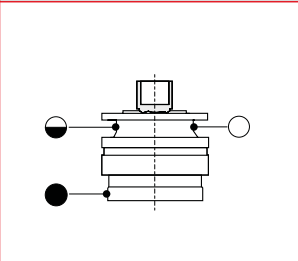
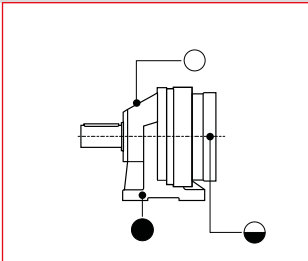
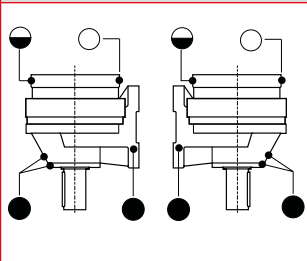
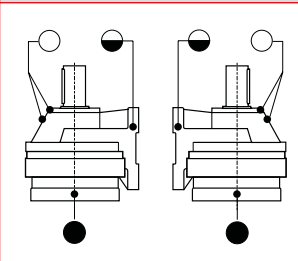
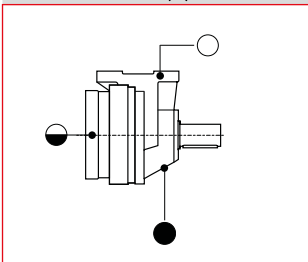
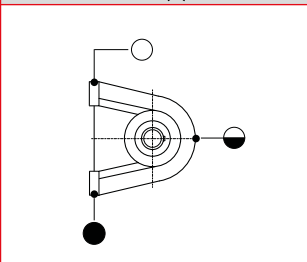
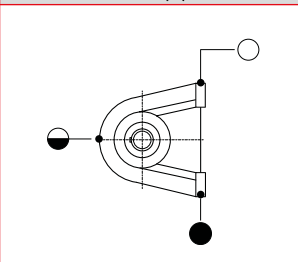
POSIZIONI DI MONTAGGIO · MOUNTING POSITIONS

CMS CMC			
	B5 (A)	V1 (B)	V3 (C)
CPS CPC			
	B5 (A)	V1 (B)	V3 (C)
CF			
	B5 (A)	V1 (B)	V3 (C)
CFS			
	B5 (A)	V1 (B)	V3 (C)
CCPC			
	B3 (A)	V2 (B)	V4 (C)
			
	B8 (D)	B6 (E)	B7 (F)

 Tappo di carico/sfiato olio
Oil filling/vent plug

 Tappo di livello olio
Oil level plug

 Tappo di scarico olio (magnetico)
Oil drain plug (magnetic)



L'orientamento della foratura della flangia di fissaggio è come illustrato nelle schede dei dati dimensionali dei riduttori.

The mounting flange orientation is shown in each planetary gears technical sheets.



I codici in parentesi sono ad uso esclusivo dell'ufficio tecnico CHIARAVALLI.
Codes in brackets are for CHIARAVALLI technical department use only.

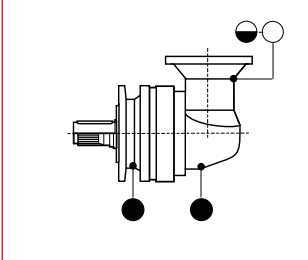
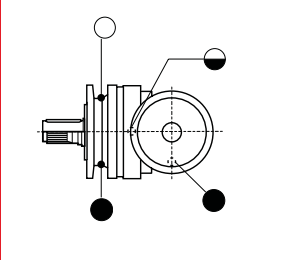
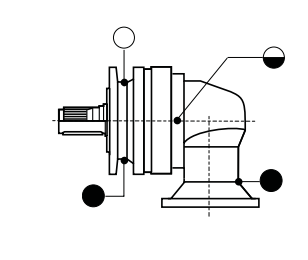
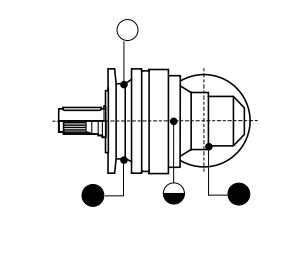
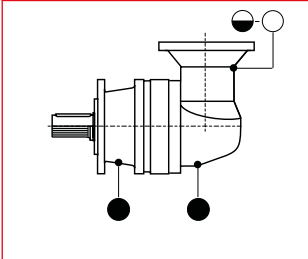
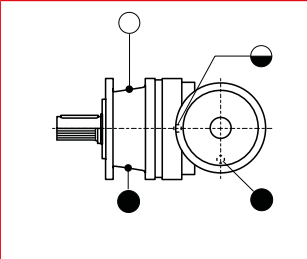
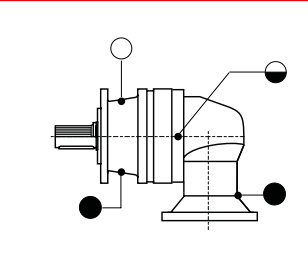
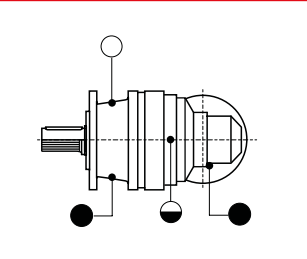
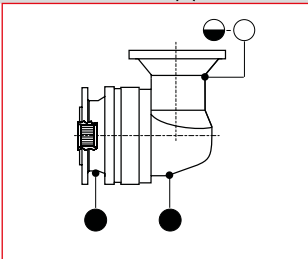
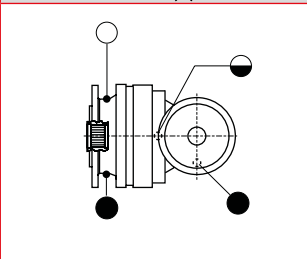
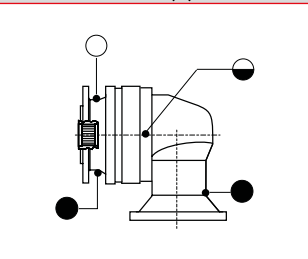
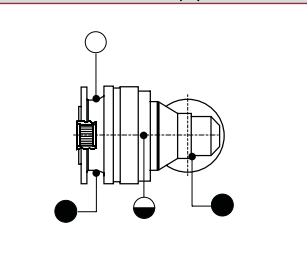
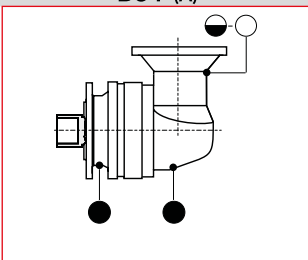
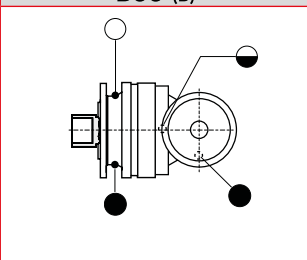
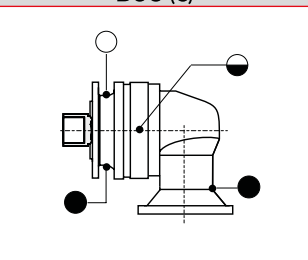
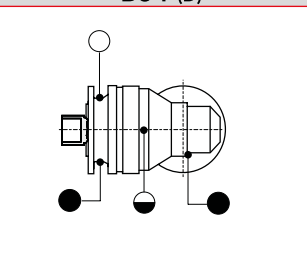
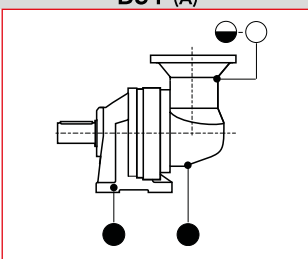
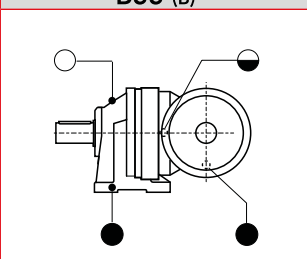
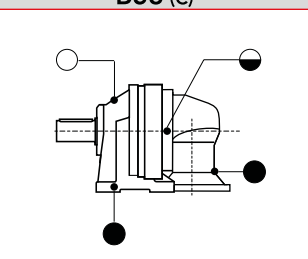
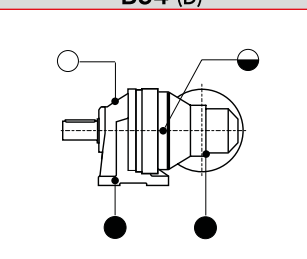
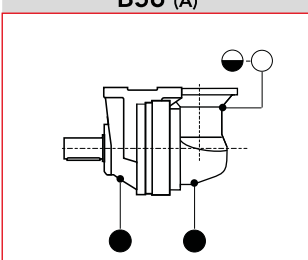
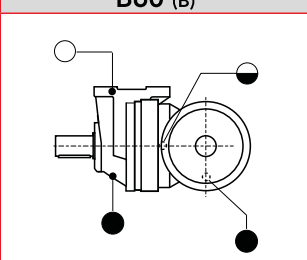
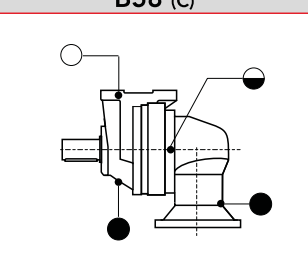
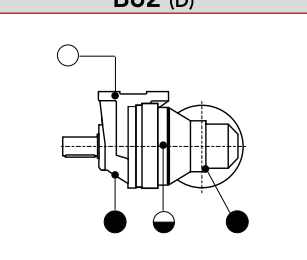

POSIZIONI DI MONTAGGIO · MOUNTING POSITIONS

CMS CMC				
	B51 (A)	B55 (B)	B53 (C)	B54 (D)
CPS CPC				
	B51 (A)	B55 (B)	B53 (C)	B54 (D)
CF				
	B51 (A)	B55 (B)	B53 (C)	B54 (D)
CFS				
	B51 (A)	B55 (B)	B53 (C)	B54 (D)
CCPC				
	B56 (A)	B60 (B)	B58 (C)	B62 (D)
				
	B57 (E)	B61 (F)	B59 (G)	B63 (H)



I codici in parentesi sono ad uso esclusivo dell'ufficio tecnico CHIARAVALLI.
Codes in brackets are for CHIARAVALLI technical department use only.

POSIZIONI DI MONTAGGIO · MOUNTING POSITIONS

CMS CMC				
	V15 (E)	V16 (F)	V17 (G)	V18 (H)
CPS CPC				
	V15 (E)	V16 (F)	V17 (G)	V18 (H)
CF				
	V15 (E)	V16 (F)	V17 (G)	V18 (H)
CFS				
	V15 (E)	V16 (F)	V17 (G)	V18 (H)
CCPC				
	V53 (I)	V52 (J)	V54 (K)	V55 (L)
	V49 (M)	V48 (N)	V50 (O)	V51 (P)



I codici in parentesi sono ad uso esclusivo dell' ufficio tecnico CHIARAVALLI.
Codes in brackets are for CHIARAVALLI technical department use only.



POSIZIONI DI MONTAGGIO · MOUNTING POSITIONS

CMS CMC				
	V35 (I)	V36 (J)	V37 (K)	V38 (L)
CPS CPC				
	V35 (I)	V36 (J)	V37 (K)	V38 (L)
CF				
	V35 (I)	V36 (J)	V37 (K)	V38 (L)
CFS				
	V35 (I)	V36 (J)	V37 (K)	V38 (L)
CCPC				
	V42 (Q)	V40 (R)	V41 (S)	V43 (T)
	V46 (U)	V44 (V)	V45 (W)	V47 (X)



I codici in parentesi sono ad uso esclusivo dell' ufficio tecnico CHIARAVALLI.
Codes in brackets are for CHIARAVALLI technical department use only.

POSIZIONI DI MONTAGGIO · MOUNTING POSITIONS

CMS
CMC
CPS
CPC
CF
CFS

C1 (01)	C2 (02)	C3 (03)	C4 (04)
C5 (05)	C6 (06)	C7 (07)	C8 (08)
C9 (01)	C10 (02)	C11 (03)	C12 (04)
C13 (05)	C14 (06)	C15 (07)	C16 (08)
C17 (09)	C18 (10)	C19 (11)	C20 (12)
C21 (13)	C22 (14)	C23 (15)	C24 (16)

CCPC



I codici in parentesi sono ad uso esclusivo dell' ufficio tecnico CHIARAVALLI.
Codes in brackets are for CHIARAVALLI technical department use only.



POSIZIONI DI MONTAGGIO · MOUNTING POSITIONS

CMS CMC				
	C25 (09)	C26 (10)	C27 (11)	C28 (12)
CPS CPC				
	C25 (09)	C26 (10)	C27 (11)	C28 (12)
CF				
	C25 (09)	C26 (10)	C27 (11)	C28 (12)
CFS				
	C25 (09)	C26 (10)	C27 (11)	C28 (12)
CCPC				
	C41 (17)	C42 (18)	C43 (19)	C44 (20)
	C45 (21)	C46 (22)	C47 (23)	C48 (24)



I codici in parentesi sono ad uso esclusivo dell' ufficio tecnico CHIARAVALLI.
Codes in brackets are for CHIARAVALLI technical department use only.

POSIZIONI DI MONTAGGIO · MOUNTING POSITIONS

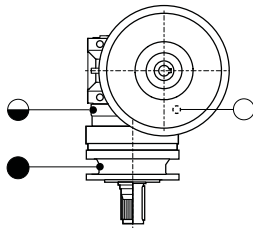
CMS
CMC

C29 (13)

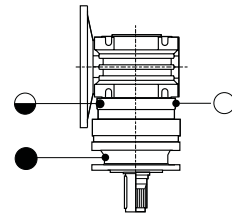

C30 (14)

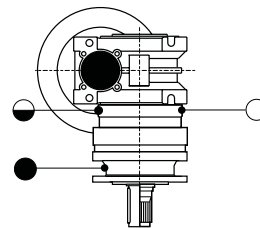

C31 (15)

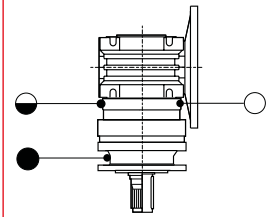

C32 (16)

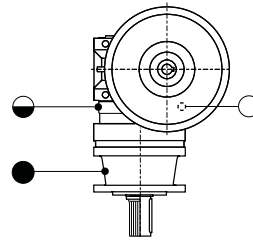
CPS
CPC

C29 (13)

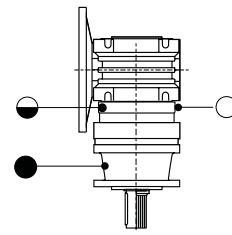

C30 (14)

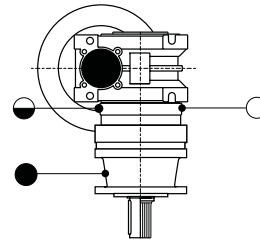

C31 (15)

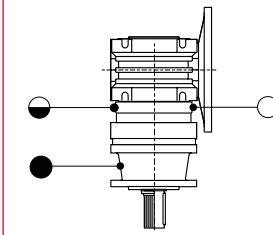

C32 (16)

CF

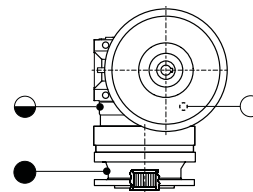

C29 (13)

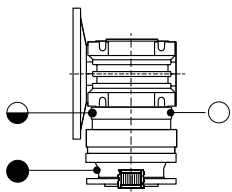

C30 (14)

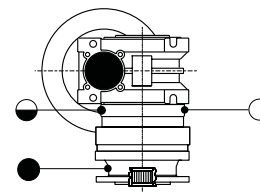

C31 (15)

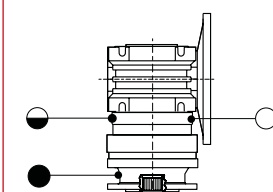

C32 (16)

CFS

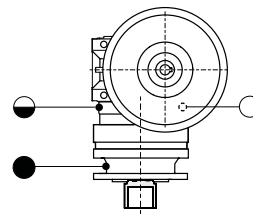

C29 (13)

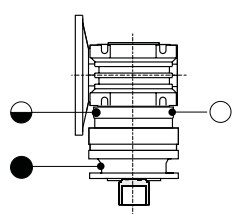

C30 (14)

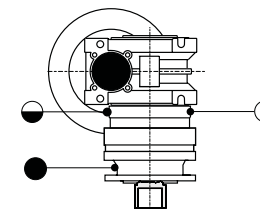

C31 (15)

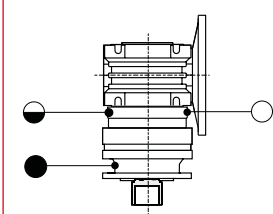

C32 (16)

CCPC

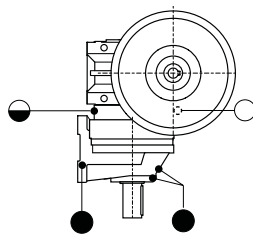

C49 (25)

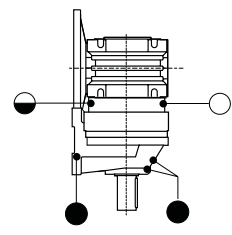

C50 (26)

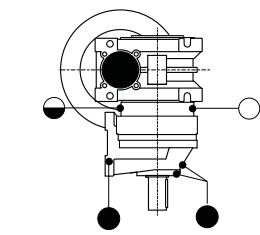

C51 (27)

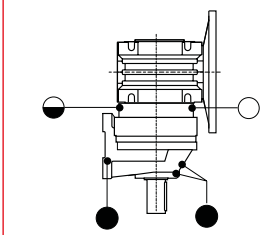

C52 (28)

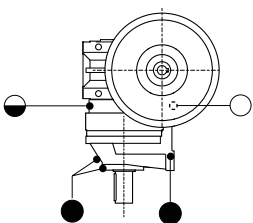

C53 (29)

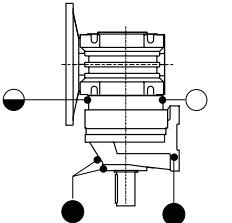

C54 (30)

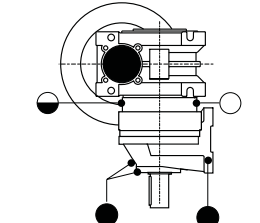

C55 (31)

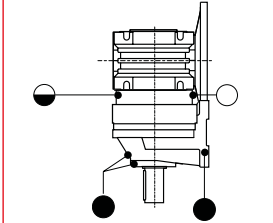

C56 (32)



I codici in parentesi sono ad uso esclusivo dell' ufficio tecnico CHIARAVALLI.
Codes in brackets are for CHIARAVALLI technical department use only.



POSIZIONI DI MONTAGGIO · MOUNTING POSITIONS

CMS CMC					
	C33 (17)	C34 (18)	C35 (19)	C36 (20)	
	CPS CPC				
		C33 (17)	C34 (18)	C35 (19)	C36 (20)
CF					
		C33 (17)	C34 (18)	C35 (19)	C36 (20)
	CFS				
		C33 (17)	C34 (18)	C35 (19)	C36 (20)
CCPC					
		C57 (33)	C58 (34)	C59 (35)	C60 (36)
	C61 (37)	C62 (38)	C63 (39)	C64 (40)	



I codici in parentesi sono ad uso esclusivo dell'ufficio tecnico CHIARAVALLI.
Codes in brackets are for CHIARAVALLI technical department use only.

POSIZIONI DI MONTAGGIO · MOUNTING POSITIONS

CMS CMC				
	C37 (21)	C38 (22)	C39 (23)	C40 (24)
CPS CPC				
	C37 (21)	C38 (22)	C39 (23)	C40 (24)
CF				
	C37 (21)	C38 (22)	C39 (23)	C40 (24)
CFS				
	C37 (21)	C38 (22)	C39 (23)	C40 (24)
CCPC				
	C65 (41)	C66 (42)	C67 (43)	C68 (44)
	C69 (45)	C70 (46)	C71 (47)	C72 (48)



I codici in parentesi sono ad uso esclusivo dell' ufficio tecnico CHIARAVALLI.
Codes in brackets are for CHIARAVALLI technical department use only.

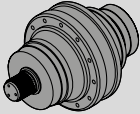
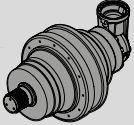

SIZE	 CHPL _i	 CHPLB _i	T_{2n} ($n_1 = 1400$ rpm) [Nm]	PAGE
1000	3.56 - 3422.2	10.4 - 1487.2	1000	B1
1600	3.56 - 3422.2	10.4 - 1487.2	1600	C1
2500	3.78 - 2369.2	12.1 - 1244.1	2500	D1
5000	3.78 - 1845.3	13.1 - 1244.1	5000	E1
7000	3.67 - 2968.9	12.7 - 1069.0	7000	F1
10000	3.56 - 2229.7	12.3 - 969.0	10000	G1
16000	3.56 - 2229.7	12.3 - 969.0	16000	H1
18000	13.0 - 1216.4	10.9 - 981.2	18000	I1
25000	4.00 - 1774.0	12.3 - 1726.9	25000	L1
30000	14.2 - 1425.1	52.7 - 1385.5	30000	M1
35000	4.00 - 1289.7	12.3 - 1253.8	35000	N1

per ulteriori rapporti consultare l'ufficio tecnico

for information consult the technical office



Maschio cilindrico con chiavetta
Cylindrical male with keyway

Ø mm	SIZE	page	Ø mm	SIZE	page
38			80	7000	F1
42	1000 1600	B1 C1	90	10000	G1
50			100	16000 18000	H1 I1
60	2500 5000	D1 E1	110	25000 30000	L1 M1
65			120	35000	N1



Maschio brocciato
Splined male shaft

SPLINED	SIZE	page
40 x 36 DIN 5482	1000 / 1600	B1/C1
58 x 53 DIN 5482	2500 / 5000	D1/E1
70 x 64 DIN 5482	7000	F1
80 x 74 DIN 5482	10000 / 16000 CMS 18000 CMS	G1/ H1/I1
100 x 94 DIN 5482	16000 CPS / 18000 CPS 25000 / 30000	H1/I1 L1/M1
W120 x 5 x 22 x 9H DIN 5480	35000	N1



Femmina brocciato
Splined female shaft

SPLINED	SIZE	page
40 x 36 DIN 5482	1000 / 1600	B1/C1
58 x 53 DIN 5482	2500 / 5000	D1/E1
70 x 64 DIN 5482	7000	F1
80 x 74 DIN 5482	10000 / 16000 18000	G1/ H1/I1
100 x 94 DIN 5482	25000 / 30000	H1/I1
W120 x 5 x 22 x 9H DIN 5480	35000	N1



Calettatore
Clamping device

Ø mm	SIZE	page
50	1000 / 1600	B1/C1
75	2500 / 5000	D1/E1
90	7000	F1
100	10000	G1
120	16000 / 18000	H1/I1
135	25000 / 30000 / 35000	L1/M1/N1



CHPL

1001	i 3.56 ÷ 8.67	1 reduction stage
1002	12.6 ÷ 58.5	2 reduction stages
1003	54.2 ÷ 394.9	3 reduction stages
1004	337.4 ÷ 3422.2	4 reduction stages

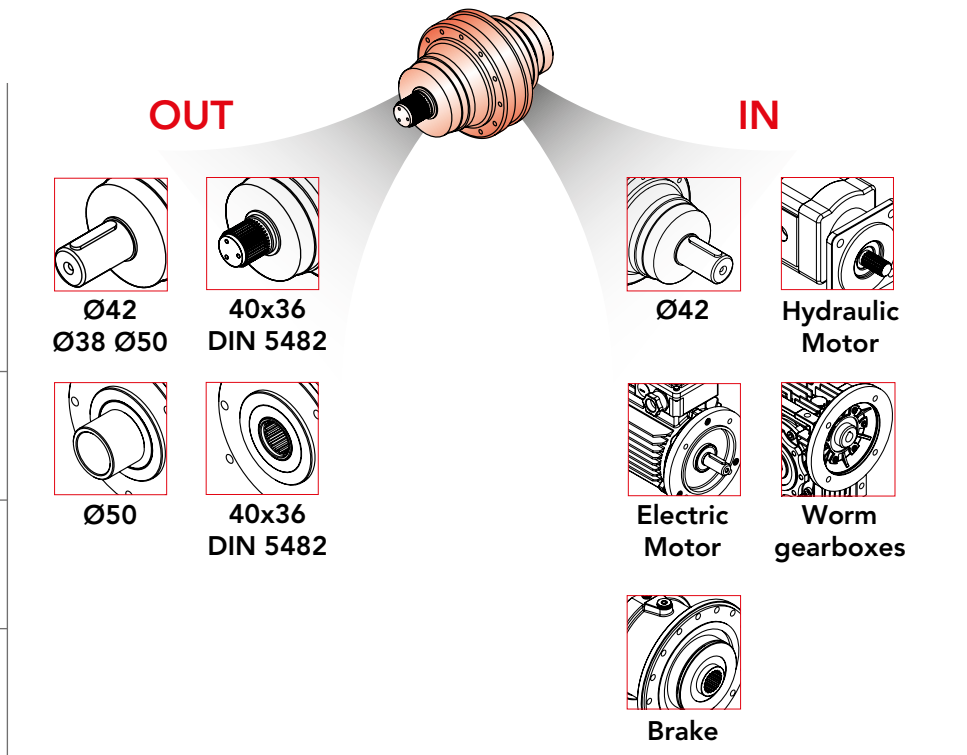

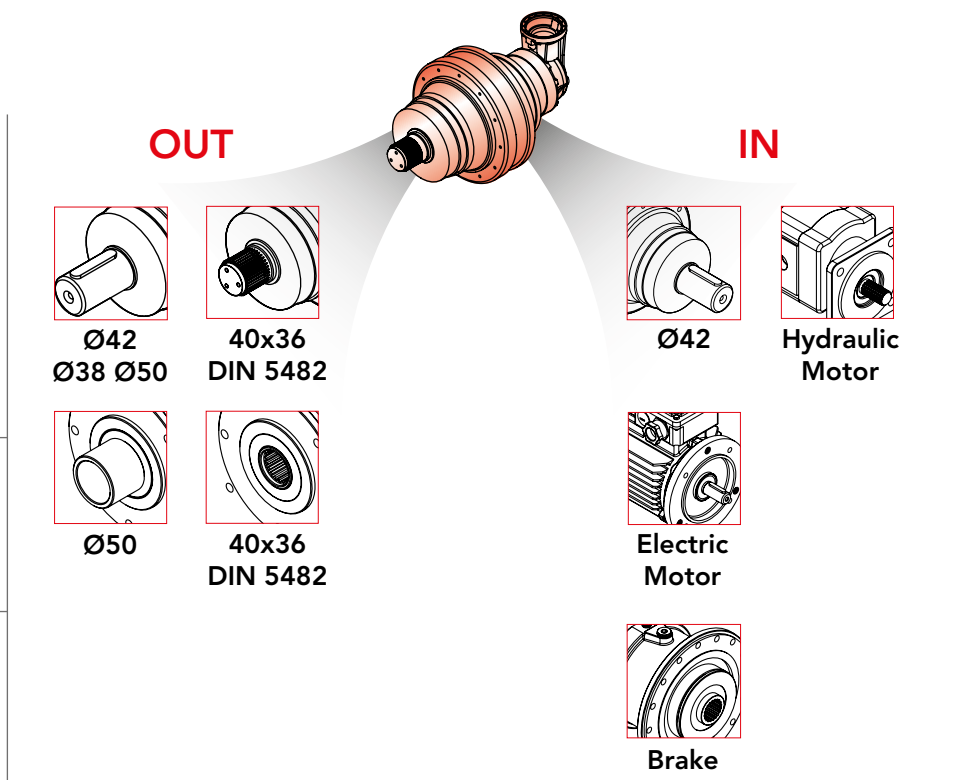

CHPLB

1002	i 10.4 ÷ 19.8	2 reduction stages
1003	37.1 ÷ 171.6	3 reduction stages
1004	131.8 ÷ 1487.2	4 reduction stages

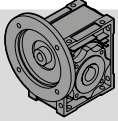

DATI TECNICI · TECHNICAL DATA

CHPL	i	T _{2n} (n ₁ = 1400 rpm) 10.000h FS=1 [Nm]	P _{1n} (n ₁ = 1400 rpm) 10.000h FS=1 [kW]	T ₂ Max [Nm]	P _t 1400 rpm [kW]	IEC			
						(B5)			
1001	3.56	458	19.5	2240	12	63 80 100 132	71 90 112 160	CHM 50 CHM 63 CHM 75	CM42
	4.29	465	16.5	2240					
	5.6	368	10	1640					
	6.75	319	7.2	1420					
	8.67	214	3.74	920					
1002	12.6	576	7.2	2240	8	63 80 100 132	71 90 112	CHM 50 CHM 63 CHM 75	CM42
	15.2	594	6.16	2240					
	19.9	612	4.84	2240					
	24	641	4.2	2240					
	28.9	660	3.6	2240					
	31.4	482	2.42	1640					
	37.8	504	2.1	1640					
	45.6	461	1.6	1420					
58.5	469	1.27	1420						
1003	54.2	722	2.18	2240	5	63 80 100 132	71 90 112	CHM 50 CHM 63 CHM 75	CM42
	65.3	750	1.88	2240					
	70.8	750	1.73	2240					
	78.7	795	1.65	2240					
	85.3	806	1.54	2240					
	102.9	833	1.32	2240					
	111.5	827	1.21	2240					
	134.4	854	1.04	2240					
	162	881	0.89	2240					
	172.6	899	0.85	2240					
	208	925	0.73	2240					
	211.7	679	0.52	1640					
	255.2	705	0.45	1640					
	271.8	690	0.41	1640					
	307.5	633	0.34	1420					
	327.6	723	0.36	1640					
	394.9	638	0.26	1420					
1004	337.4	1005	0.50	2240	1.5	63 80	71 90	CHM 50 CHM 63 CHM 75	CM42
	365.7	1011	0.47	2240					
	396.4	1013	0.43	2240					
	440.8	1032	0.40	2240					
	477.9	1069	0.38	2240					
	531.3	1094	0.35	2240					
	576	1105	0.32	2240					
	624.4	1108	0.30	2240					
	694.3	1134	0.28	2240					
	752.6	1122	0.25	2240					
	836.9	1188	0.24	2240					
	907.2	1224	0.23	2240					
	966.3	1235	0.22	2240					
	1093.5	1242	0.19	2240					
	1144.5	1218	0.18	2240					
	1185.4	926	0.13	1640					
	1318.1	1311	0.17	2240					
	1428.8	913	0.11	1640					
	1692.3	1322	0.14	2240					
3422.2	923	0.05	1420						



n_{1max} = 2800 rpm

per ulteriori rapporti consultare l'ufficio tecnico

for information consult the technical office

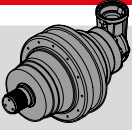

DATI TECNICI · TECHNICAL DATA

 CHPLB	i	T _{2n} (n ₁ = 1400 rpm) 10.000h FS=1 [Nm]	P _{1n} (n ₁ = 1400 rpm) 10.000h FS=1 [kW]	T ₂ Max [Nm]	P _t 1400 rpm [kW]	IEC (B5)		 CM
1002	10.4	554	8.40	2240	8	63	71	CM42
	12.6	576	7.20	2240		80	90	
	16.4	437	4.20	1640		100	112	
	19.8	386	3.08	1420		132		
1003	37.1	700	3.08	2240	5	63	71	CM42
	44.7	722	2.64	2240		80	90	
	53.9	744	2.25	2240		100	112	
	58.4	750	2.10	2240		132		
	70.4	778	1.80	2240				
	84.9	801	1.54	2240				
	92	585	1.04	1640				
	110.9	605	0.89	1640				
	133.6	545	0.67	1420				
	171.6	567	0.54	1420				
1004	131.8	864	1.11	2240	1.5	63	71	CM42
	158.9	870	0.93	2240		80	90	
	191.6	922	0.81	2240				
	207.7	921	0.75	2240				
	230.9	955	0.70	2240				
	301.7	981	0.55	2240				
	327.1	974	0.50	2240				
	363.7	1006	0.47	2240				
	394.2	1008	0.43	2240				
	475.2	1063	0.38	2240				
	515.1	805	0.26	1640				
	572.8	1099	0.32	2240				
	610.1	1126	0.31	2240				
	735.4	1149	0.26	2240				
	797.2	849	0.18	1640				
	960.9	887	0.16	1640				
	1158.3	822	0.12	1420				
	1233.8	876	0.12	1640				
1487.2	845	0.09	1420					

n_{1max} = 2800 rpm

per ulteriori rapporti consultare l'ufficio tecnico

for information consult the technical office

DIMENSIONI · DIMENSIONS

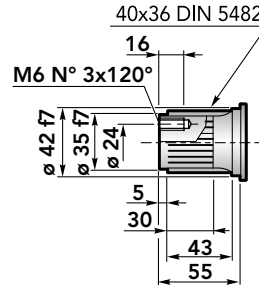
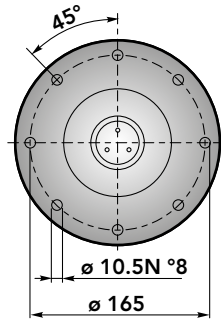
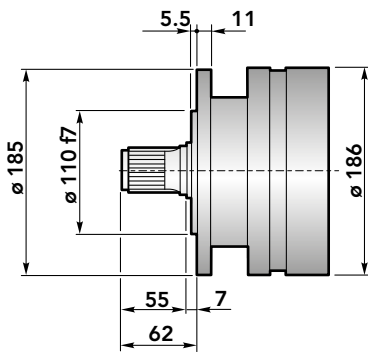

Accessori
Accessories



CHPL 1000 CMS - Flange motori IEC | IEC Motor flanges

CHPL	IEC 63			IEC 71			IEC 80			IEC 90				
	Lp	P	ØD	Lp	P	ØD	Lp	P	ØD	Lp	P	ØD		
1001	140	36	140	140	36	160	56	200	208	56	200	208		
1002	188			188									256	304
1003	236			236									304	304
1004	284			284									304	304

CHPL	IEC 100			IEC 112			IEC 132			IEC 160				
	Lp	P	ØD	Lp	P	ØD	Lp	P	ØD	Lp	P	ØD		
1001	170	66	250	170	66	250	100	300	243	139	350	-		
1002	218			218									300	300
1003	266			266									300	300
1004	-			-									-	-

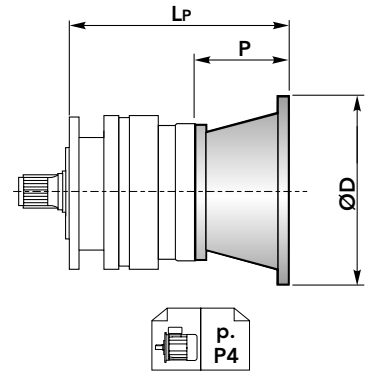

CHPL 1000 CMS - Alberi maschi entrata | Male input shafts

CHPL	CM42			
	Lt	T	LE	ØE
1001	197	93	82	42 h6
1002	245			
1003	293			
1004	341			

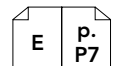
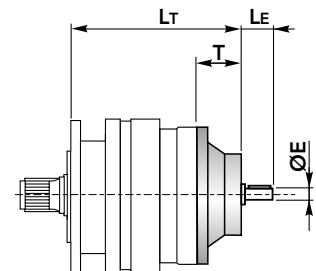



DIMENSIONI · DIMENSIONS

CHPL 1000 CMS - Riduttore a vite senza fine CHM in entrata | *CHM input worm gearboxes*

CHPL	CHM 50					CHM 63				
	Lv	I	H	M	N	Lv	I	H	M	N
1001	229.5	50	110	60	80	239	63	135	72	95
1002	277.5					287				
1003	325.5					335				
1004	373.5					383				

CHPL	CHM 75				
	Lv	I	H	M	N
1001	218	75	161	86	112.5
1002	266				
1004	314				
1004	362				

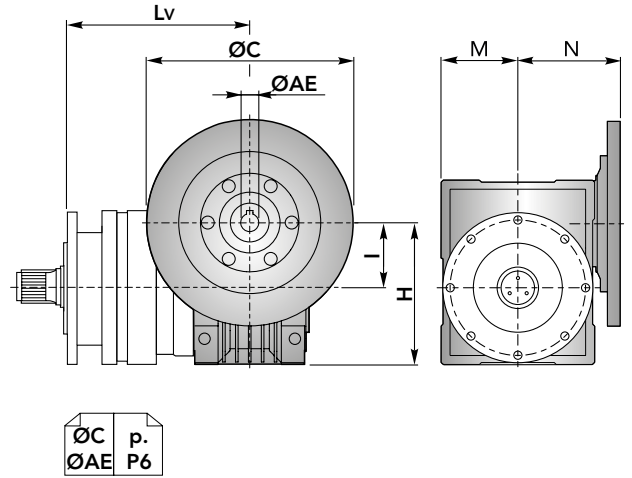

CHPL / CHPLB 1000 CMS

CHPLB 1000 CMS - Flange motori IEC | *IEC Motor flanges*

CHPLB	IEC 63				IEC 71				IEC 80				IEC 90				
	L	LP	P	ØD	L	LP	P	ØD	L	LP	P	ØD	L	LP	P	ØD	
1002	179				179				179				179				
1003	227	196	36	140	227	196	36	160	227	216	56	200	227	216	56	200	
1004	275				275				275				275				

CHPLB	IEC 100				IEC 112				IEC 132			
	L	LP	P	ØD	L	LP	P	ØD	L	LP	P	ØD
1002	179				179				179			
1003	227	226	66	250	227	226	66	250	227	260	100	300
1004												

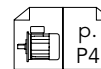
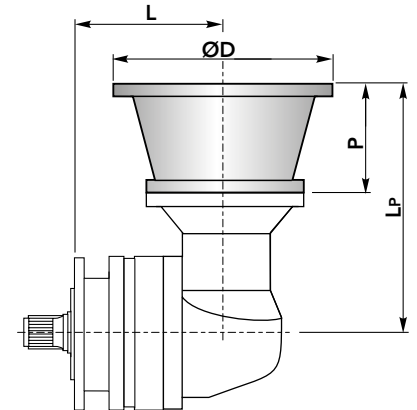

CHPLB 1000 CMS - Alberi maschi entrata | *Male input shafts*

CHPLB	CM42				
	L	Lt	T	Le	ØE
1002	179				
1003	227	253	93	82	42 h6
1004	275				

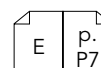
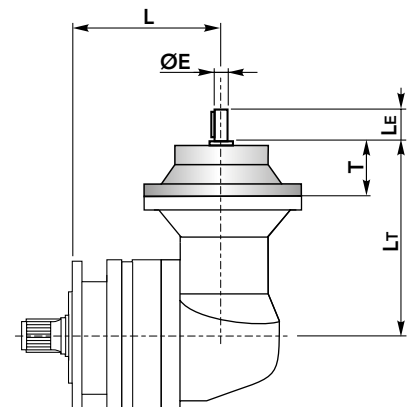

DIMENSIONI · DIMENSIONS

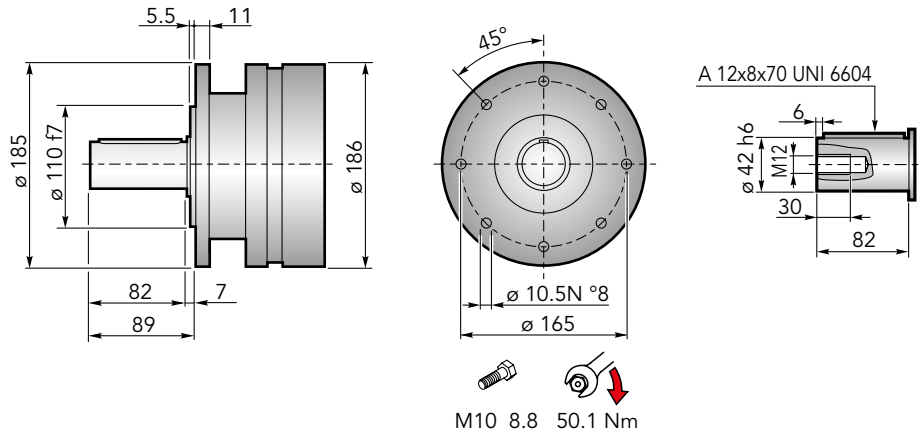

CHPL 1000 CMC - Flange motori IEC | IEC Motor flanges

CHPL	IEC 63			IEC 71			IEC 80			IEC 90		
	LP	P	ØD	LP	P	ØD	LP	P	ØD	LP	P	ØD
1001	140	36	140	140	36	160	160	56	200	160	56	200
1002	188			188			208			208		
1003	236			236			256			256		
1004	284			284			304			304		

CHPL	IEC 100			IEC 112			IEC 132			IEC 160		
	LP	P	ØD	LP	P	ØD	LP	P	ØD	LP	P	ØD
1001	170	66	250	170	66	250	204	100	300	243	139	350
1002	218			218			252			-		
1003	266			266			300			-		
1004	-			-			-			-		

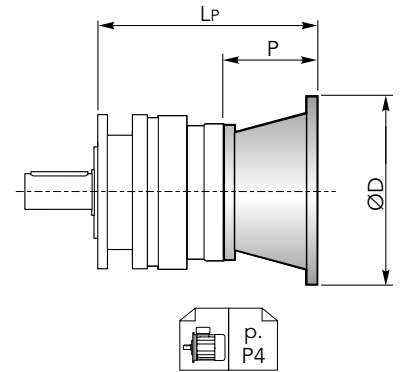

CHPL 1000 CMC - Alberi maschi entrata | Male input shafts

CHPL	CM42			
	LT	T	LE	ØE
1001	197	93	82	42 h6
1002	245			
1003	293			
1004	341			

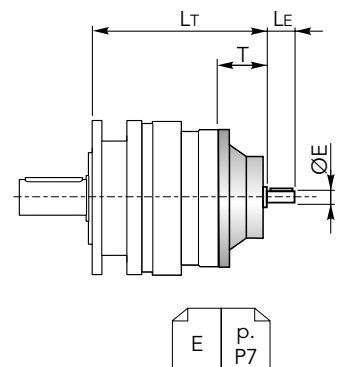



DIMENSIONI · DIMENSIONS

CHPL 1000 CMC - Riduttore a vite senza fine CHM in entrata | *CHM input worm gearboxes*

CHPL	CHM 50					CHM 63				
	Lv	I	H	M	N	Lv	I	H	M	N
1001	229.5	50	110	60	80	239	63	135	72	95
1002	277.5					287				
1003	325.5					335				
1004	373.5					383				

CHPL	CHM 75				
	Lv	I	H	M	N
1001	218	75	161	86	112.5
1002	266				
1004	314				
1004	362				

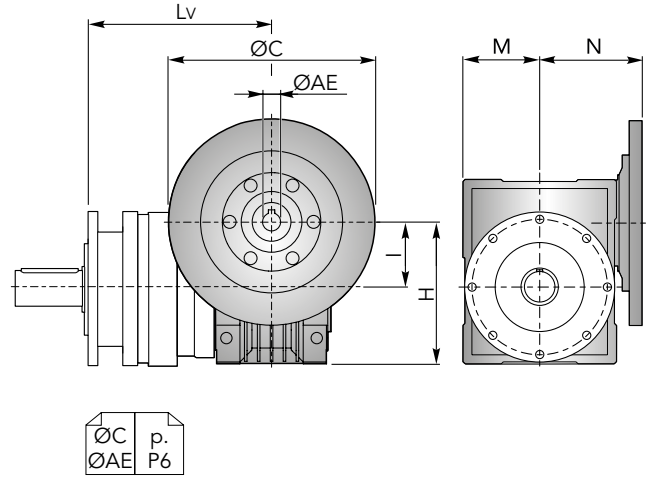

CHPL / CHPLB 1000 CMC

CHPLB 1000 CMC - Flange motori IEC | *IEC Motor flanges*

CHPLB	IEC 63				IEC 71				IEC 80				IEC 90				
	L	LP	P	ØD	L	LP	P	ØD	L	LP	P	ØD	L	LP	P	ØD	
1002	179				179				179				179				179
1003	227	196	36	140	227	196	36	160	227	216	56	200	227	216	56	200	227
1004	275				275				275				275				275

CHPLB	IEC 100				IEC 112				IEC 132				
	L	LP	P	ØD	L	LP	P	ØD	L	LP	P	ØD	
1002	179				179				179				179
1003	227	226	66	250	227	226	66	250	227	260	100	300	227
1004													

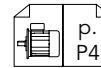
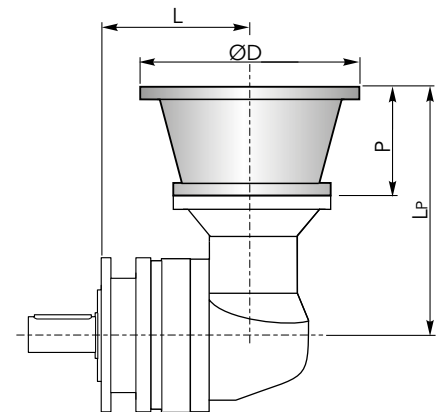

CHPLB 1000 CMC - Alberi maschi entrata | *Male input shafts*

CHPLB	CM42				
	L	L _T	T	L _E	ØE
1002	179				
1003	227	253	93	82	42 h6
1004	275				

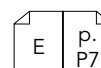
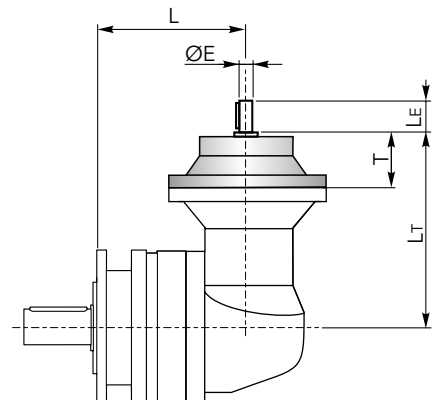

DIMENSIONI · DIMENSIONS

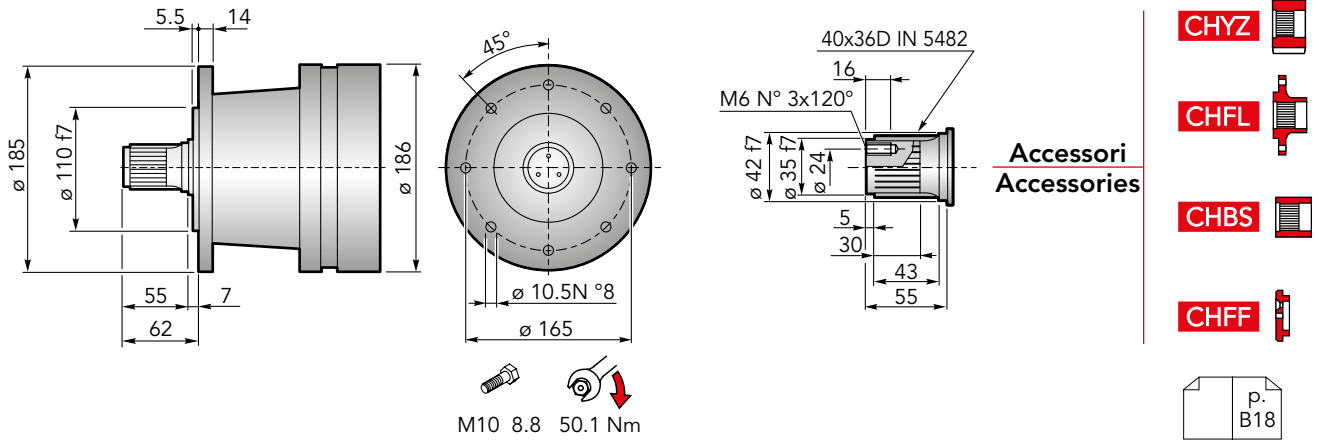

CHPL 1000 CPS - Flange motori IEC | IEC Motor flanges

CHPL	IEC 63			IEC 71			IEC 80			IEC 90				
	LP	P	ØD	LP	P	ØD	LP	P	ØD	LP	P	ØD		
1001	170			170			190			190				
1002	218	36	140	218	36	160	56	200	238	56	200	334		
1003	266			266									286	286
1004	314			314									334	334

CHPL	IEC 100			IEC 112			IEC 132			IEC 160			
	LP	P	ØD	LP	P	ØD	LP	P	ØD	LP	P	ØD	
1001	200			200			234			273	139	350	
1002	248	66	250	248	66	250	282	100	300	-			
1003	296			296						330	-		
1004	-			-						-			-

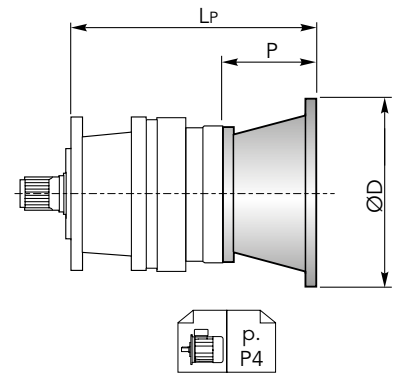

CHPL 1000 CPS - Alberi maschi entrata | Male input shafts

CHPL	CM42			
	LT	T	LE	ØE
1001	227	93	82	42 h6
1002	275			
1003	323			
1004	371			

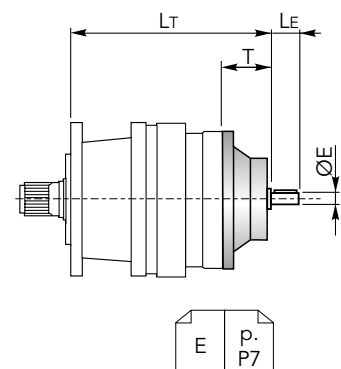



DIMENSIONI · DIMENSIONS

CHPL 1000 CPS - Riduttore a vite senza fine CHM in entrata | *CHM input worm gearboxes*

CHPL	CHM 50					CHM 63				
	Lv	I	H	M	N	Lv	I	H	M	N
1001	259.5	50	110	60	80	269	63	135	72	95
1002	307.5					317				
1003	355.5					365				
1004	403.5					413				

CHPL	CHM 75				
	Lv	I	H	M	N
1001	248	75	161	86	112.5
1002	296				
1003	344				
1004	392				

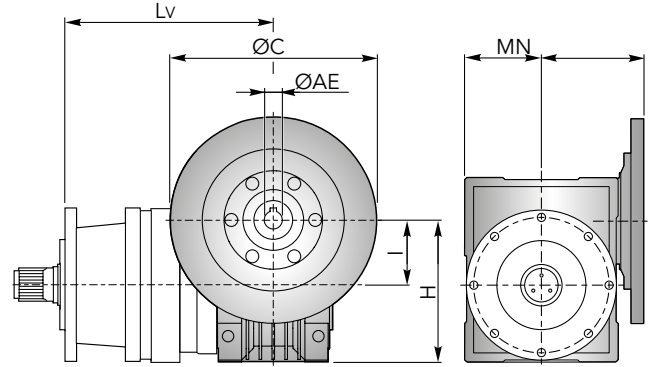

CHPL / CHPLB 1000 CPS

CHPLB 1000 CPS - Flange motori IEC | *IEC Motor flanges*

CHPLB	IEC 63				IEC 71				IEC 80				IEC 90				
	L	LP	P	ØD	L	LP	P	ØD	L	LP	P	ØD	L	LP	P	ØD	
1002	209				209				209				209				200
1003	257	196	36	140	257	196	36	160	257	216	56	200	257	216	56	200	
1004	305				305				305				305				

CHPLB	IEC 100				IEC 112				IEC 132			
	L	LP	P	ØD	L	LP	P	ØD	L	LP	P	ØD
1002	209	226	66	250	209	226	66	250	209	260	100	300
1003	257			257	250			257	300			
1004												

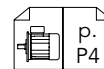
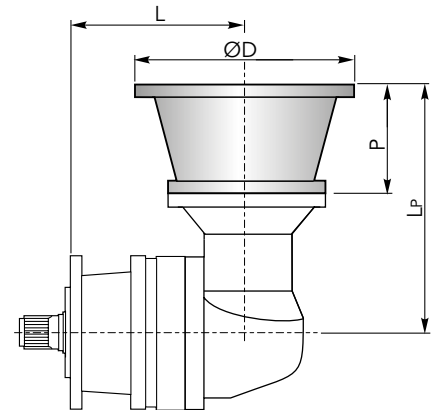

CHPLB 1000 CPS - Alberi maschi entrata | *Male input shafts*

CHPLB	CM42				
	L	Lt	T	Le	ØE
1002	209	253	93	82	42 h6
1003	257				
1004	305				

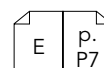
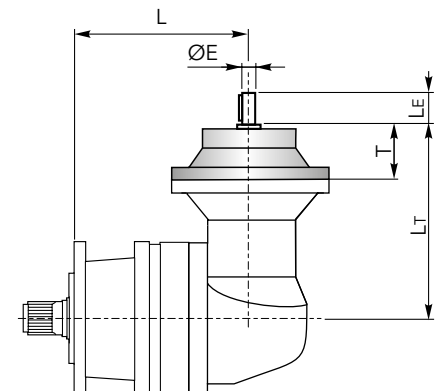

DIMENSIONI · DIMENSIONS

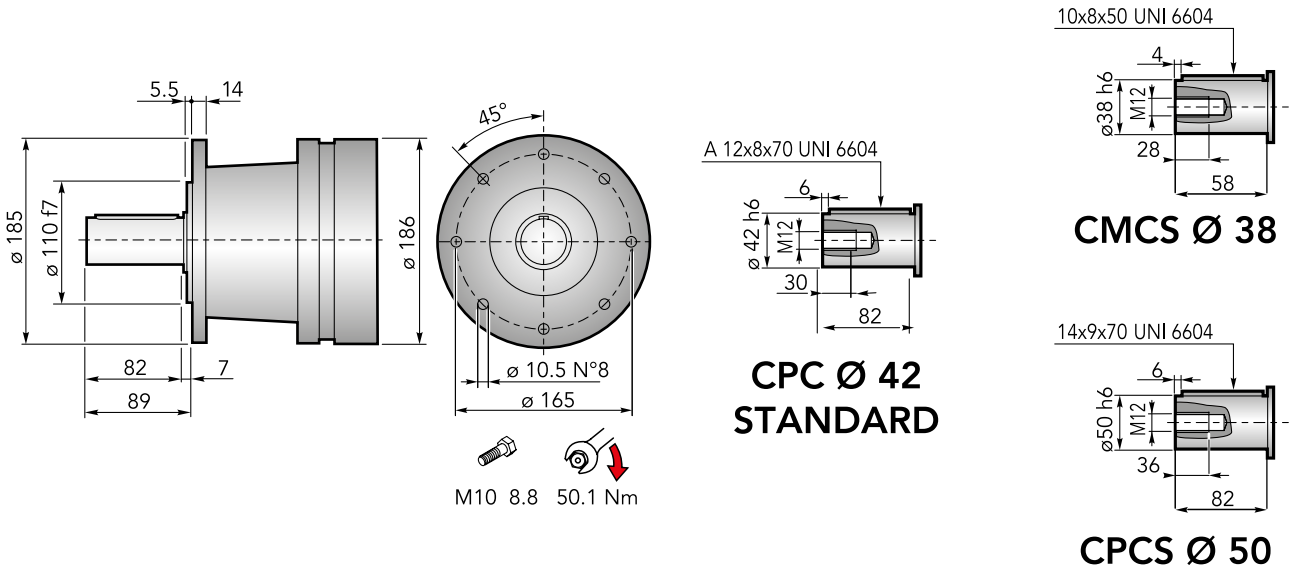

CHPL 1000 CPC - Flange motori IEC | IEC Motor flanges

CHPL	IEC 63			IEC 71			IEC 80			IEC 90			
	LP	P	ØD	LP	P	ØD	LP	P	ØD	LP	P	ØD	
1001	170			170			190			190			
1002	218	36	140	218	36	160	238	56	200	238	56	200	
1003	266			266									286
1004	314			314									334

CHPL	IEC 100			IEC 112			IEC 132			IEC 160		
	LP	P	ØD	LP	P	ØD	LP	P	ØD	LP	P	ØD
1001	200			200			234			273	139	350
1002	248	66	250	248	66	250	282	100	300	-		
1003	296			296			330			-		
1004	-			-			-			-		

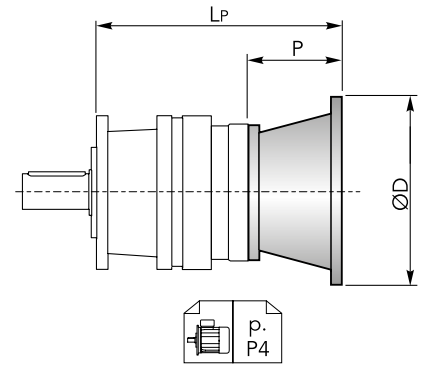

CHPL 1000 CPC - Alberi maschi entrata | Male input shafts

CHPL	CM42			
	LT	T	LE	ØE
1001	227	93	82	42 h6
1002	275			
1003	323			
1004	371			

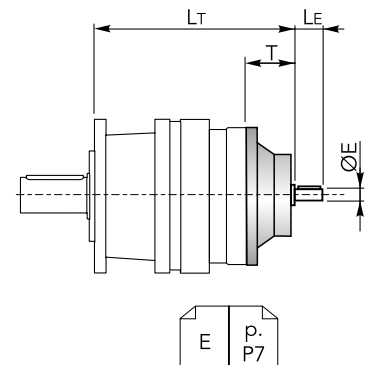



DIMENSIONI · DIMENSIONS

CHPL 1000 CPC - Riduttore a vite senza fine CHM in entrata | CHM input worm gearboxes

CHPL	CHM 50					CHM 63				
	Lv	I	H	M	N	Lv	I	H	M	N
1001	259.5	50	110	60	80	269	63	135	72	95
1002	307.5					317				
1003	355.5					365				
1004	403.5					413				

CHPL	CHM 75				
	Lv	I	H	M	N
1001	248	75	161	86	112.5
1002	296				
1003	344				
1004	392				

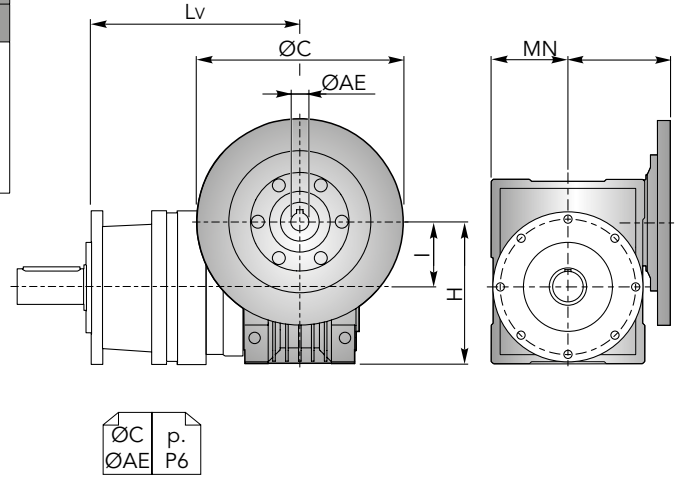

CHPL / CHPLB 1000 CPC

CHPLB 1000 CPC - Flange motori IEC | IEC Motor flanges

CHPLB	IEC 63				IEC 71				IEC 80				IEC 90					
	L	LP	P	ØD	L	LP	P	ØD	L	LP	P	ØD	L	LP	P	ØD		
1002	209	196	36	140	209	196	36	160	209	216	56	200	209	216	56	200		
1003	257				257				257				257				257	257
1004	305				305				305				305				305	305

CHPLB	IEC 100				IEC 112				IEC 132					
	L	LP	P	ØD	L	LP	P	ØD	L	LP	P	ØD		
1002	209	226	66	250	209	226	66	250	209	260	100	300		
1003	257				257				257				257	257
1004														

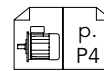
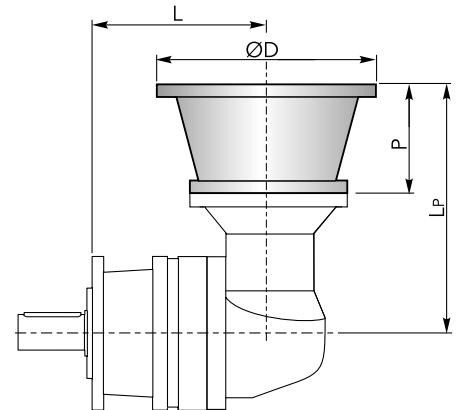

CHPLB 1000 CPC - Alberi maschi entrata | Male input shafts

CHPLB	CM42				
	L	L _T	T	L _E	ØE
1002	209	253	93	82	42 h6
1003	257				
1004	305				

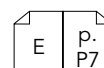
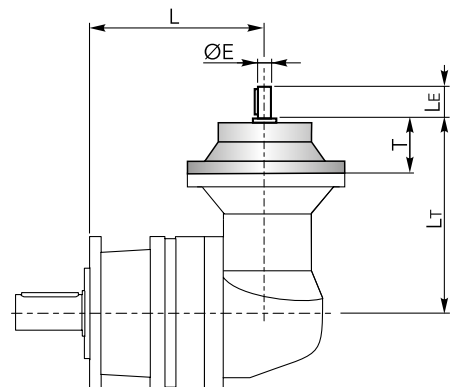

DIMENSIONI · DIMENSIONS

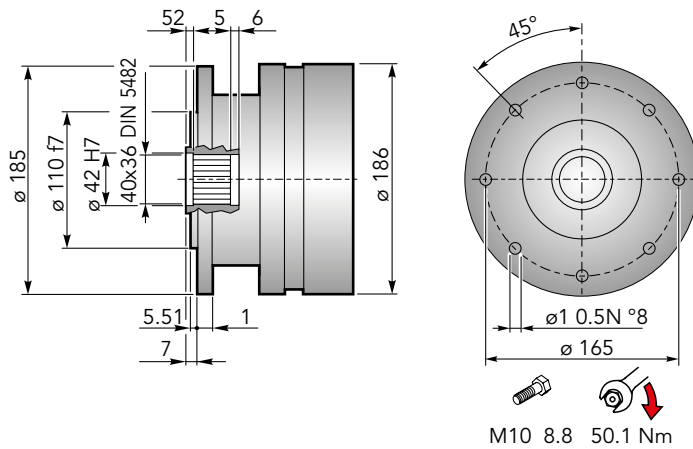

Accessori
Accessories

CHKB

p.
B18

CHPL 1000 CF - Flange motori IEC | IEC Motor flanges

CHPL	IEC 63			IEC 71			IEC 80			IEC 90		
	L _P	P	ØD	L _P	P	ØD	L _P	P	ØD	L _P	P	ØD
1001	140			140			160			160		
1002	188	36	140	188	36	160	208	56	200	208	56	200
1003	236			236			256			256		
1004	284			284			304			304		
CHPL	IEC 100			IEC 112			IEC 132			IEC 160		
	L _P	P	ØD	L _P	P	ØD	L _P	P	ØD	L _P	P	ØD
1001	170			170			204			243	139	350
1002	218	66	250	218	66	250	252	100	300	-		
1003	266			266			300			-		
1004	-			-			-			-		

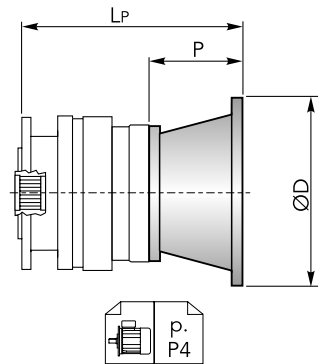

CHPL 1000 CF - Alberi maschi entrata | Male input shafts

CHPL	CM42			
	L _T	T	L _E	ØE
1001	197			
1002	245	93	82	42 h6
1003	293			
1004	341			

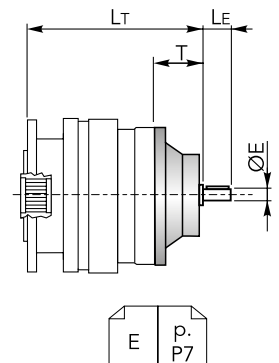



DIMENSIONI · DIMENSIONS

CHPL 1000 CF - Riduttore a vite senza fine CHM in entrata | CHM input worm gearboxes

CHPL	CHM 50					CHM 63				
	Lv	I	H	M	N	Lv	I	H	M	N
1001	229.5	50	110	60	80	239	63	135	72	95
1002	277.5					287				
1003	325.5					335				
1004	373.5					383				

CHPL	CHM 75				
	Lv	I	H	M	N
1001	218	75	161	86	112.5
1002	266				
1004	314				
1004	362				

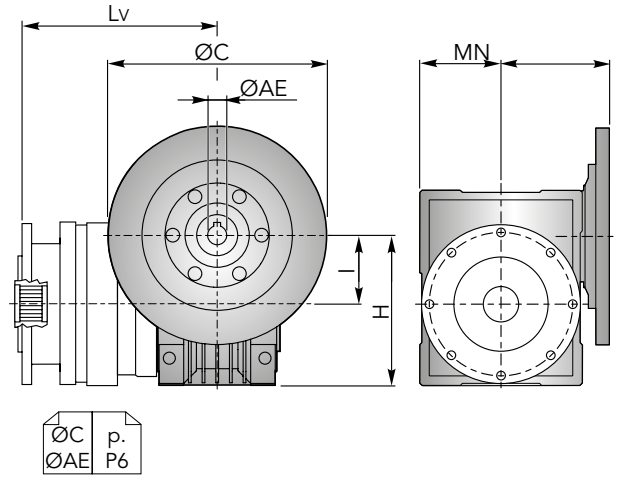

CHPL / CHPLB 1000 CF

CHPLB 1000 CF - Flange motori IEC | IEC Motor flanges

CHPLB	IEC 63				IEC 71				IEC 80				IEC 90			
	L	LP	P	ØD	L	LP	P	ØD	L	LP	P	ØD	L	LP	P	ØD
1002	179				179				179				179			
1003	227	196	36	140	227	196	36	160	227	216	56	200	227	216	56	200
1004	275				275				275				275			

CHPLB	IEC 100				IEC 112				IEC 132			
	L	LP	P	ØD	L	LP	P	ØD	L	LP	P	ØD
1002	179	226	66	250	179	226	66	250	179	260	100	300
1003	227				227				227			
1004												

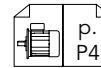
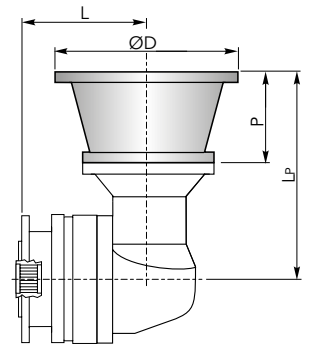

CHPLB 1000 CF - Alberi maschi entrata | Male input shafts

CHPLB	CM42				
	L	LT	T	LE	ØE
1002	179	253	93	82	42 h6
1003	227				
1004	275				

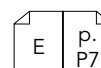
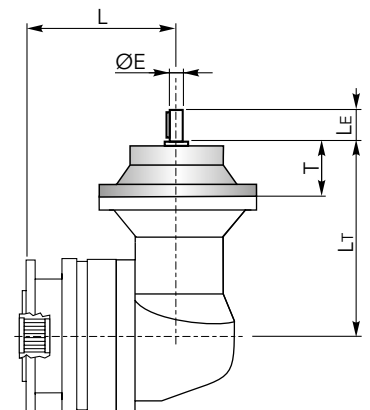

DIMENSIONI · DIMENSIONS

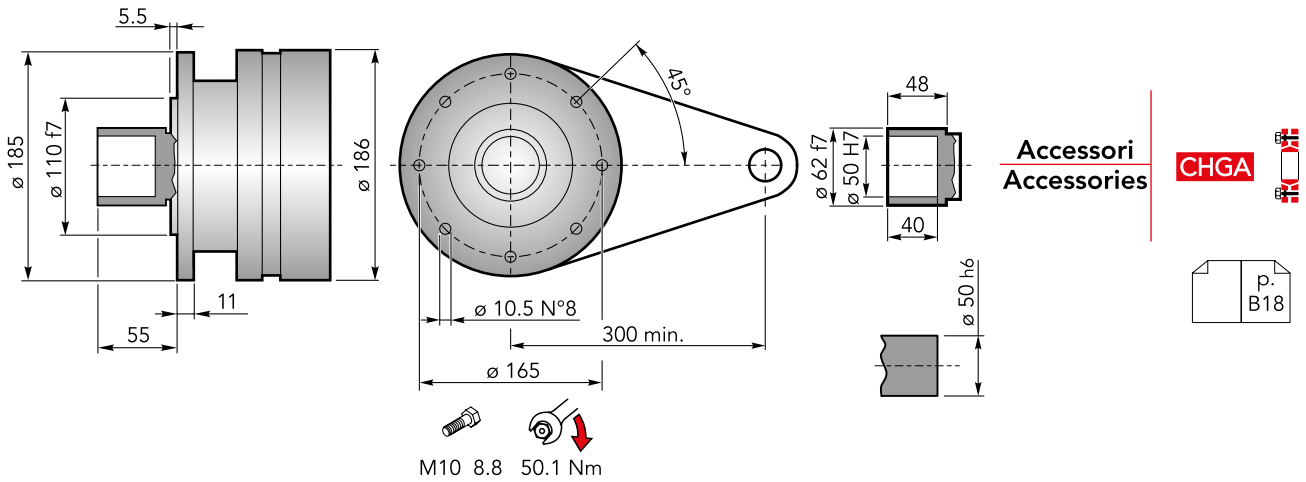

CHPL 1000 CFS - Flange motori IEC | IEC Motor flanges

CHPL	IEC 63			IEC 71			IEC 80			IEC 90		
	LP	P	ØD	LP	P	ØD	LP	P	ØD	LP	P	ØD
1001	140			140			160			160		
1002	188	36	140	188	36	160	208	56	200	208	56	200
1003	236			236			256			256		
1004	284			284			304			304		
CHPL	IEC 100			IEC 112			IEC 132			IEC 160		
	LP	P	ØD	LP	P	ØD	LP	P	ØD	LP	P	ØD
1001	170			170			204			243	139	350
1002	218	66	250	218	66	250	252	100	300	-		
1003	266			266			300			-		
1004	-			-			-			-	-	-

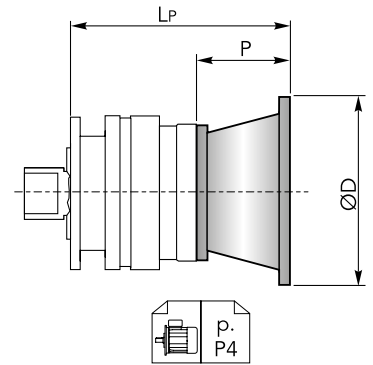

CHPL 1000 CFS - Alberi maschi entrata | Male input shafts

CHPL	CM42			
	LT	T	LE	ØE
1001	197			
1002	245	93	82	42 h6
1003	293			
1004	341			

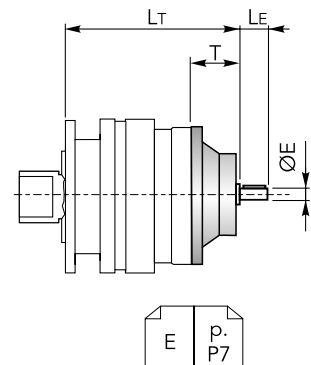



DIMENSIONI · DIMENSIONS

CHPL 1000 CFS - Riduttore a vite senza fine CHM in entrata | CHM input worm gearboxes

CHPL	CHM 50					CHM 63				
	Lv	I	H	M	N	Lv	I	H	M	N
1001	229.5	50	110	60	80	239	63	135	72	95
1002	277.5					287				
1003	325.5					335				
1004	373.5					383				

CHPL	CHM 75				
	Lv	I	H	M	N
1001	218	75	161	86	112.5
1002	266				
1004	314				
1004	362				

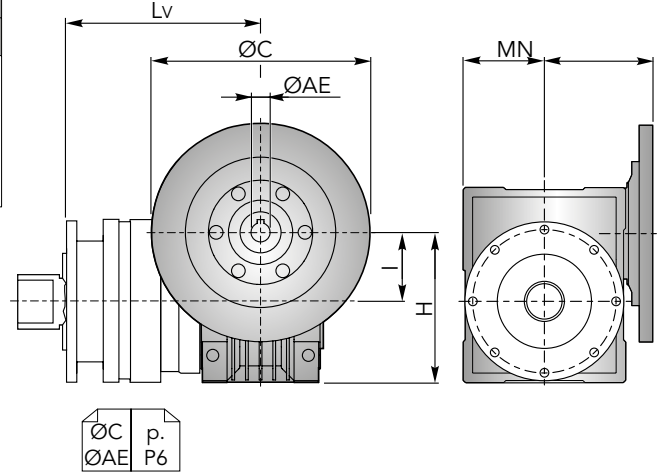

CHPL / CHPLB 1000 CFS

CHPLB 1000 CFS - Flange motori IEC | IEC Motor flanges

CHPLB	IEC 63				IEC 71				IEC 80				IEC 90			
	L	LP	P	ØD	L	LP	P	ØD	L	LP	P	ØD	L	LP	P	ØD
1002	179	196	36	140	179	196	36	160	179	216	56	200	179	216	56	200
1003	227				227				227							
1004	275				275				275							

CHPLB	IEC 100				IEC 112				IEC 132			
	L	LP	P	ØD	L	LP	P	ØD	L	LP	P	ØD
1002	179	226	66	250	179	226	66	250	179	260	100	300
1003	227				227				227			
1004												

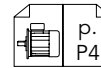
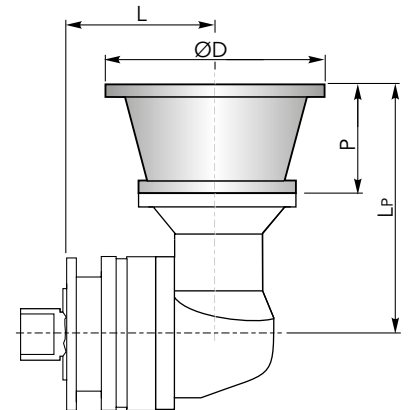

CHPLB 1000 CFS - Alberi maschi entrata | Male input shafts

CHPLB	CM42				
	L	L _T	T	L _E	ØE
1002	179	253	93	82	42 h6
1003	227				
1004	275				

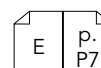
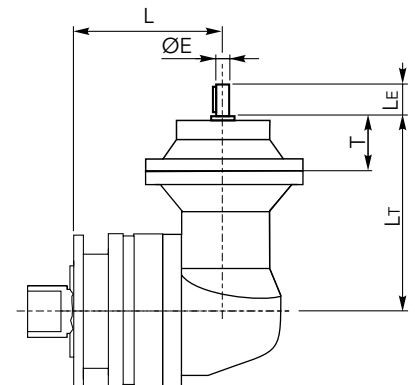

DIMENSIONI · DIMENSIONS

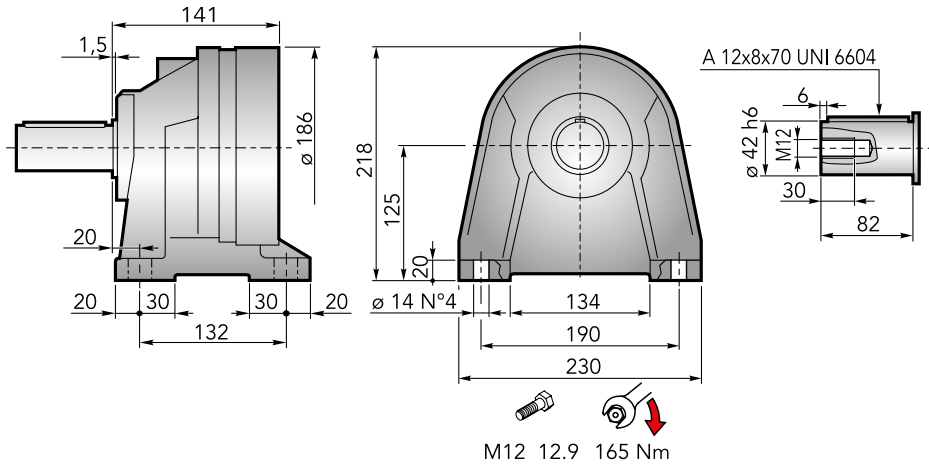

CHPL 1000 CCPC - Flange motori IEC | IEC Motor flanges

CHPL	IEC 63			IEC 71			IEC 80			IEC 90			
	LP	P	ØD	LP	P	ØD	LP	P	ØD	LP	P	ØD	
1001	177	36	140	177	36	160	56	200	245	56	200	341	
1002	225			225									293
1003	273			273									341
1004	321			321									341

CHPL	IEC 100			IEC 112			IEC 132			IEC 160			
	LP	P	ØD	LP	P	ØD	LP	P	ØD	LP	P	ØD	
1001	207	66	250	207	66	250	100	300	280	139	350	-	
1002	255			255									337
1003	303			303									337
1004	-			-									-

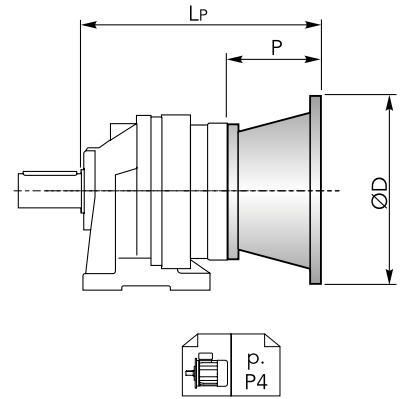

CHPL 1000 CCPC - Alberi maschi entrata | Male input shafts

CHPL	CM42			
	LT	T	LE	ØE
1001	234	93	82	42 h6
1002	282			
1003	330			
1004	379			

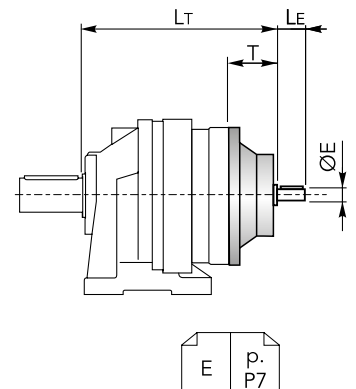



DIMENSIONI · DIMENSIONS

CHPL 1000 CCPC - Riduttore a vite senza fine CHM in entrata | *CHM input worm gearboxes*

CHPL	CHM 50					CHM 63				
	Lv	I	H	M	N	Lv	I	H	M	N
1001	266.5	50	110	60	80	276	63	135	72	95
1002	314.5					324				
1003	362.5					372				
1004	410.5					420				

CHPL	CHM 75				
	Lv	I	H	M	N
1001	255	75	161	86	112.5
1002	303				
1003	351				
1004	399				

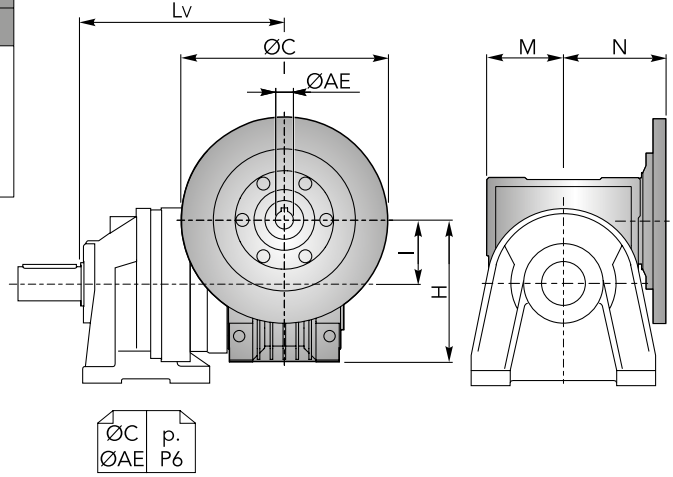

CHPL / CHPLB 1000 CCPC

CHPLB 1000 CCPC - Flange motori IEC | *IEC Motor flanges*

CHPLB	IEC 71				IEC 71				IEC 80				IEC 90				
	L	LP	P	ØD	L	LP	P	ØD	L	LP	P	ØD	L	LP	P	ØD	
1002	216				216				216				216				216
1003	264	196	36	140	264	196	36	160	264	216	56	200	264	216	56	200	264
1004	312				312				312				312				312

CHPLB	IEC 100				IEC 112				IEC 132				
	L	LP	P	ØD	L	LP	P	ØD	L	LP	P	ØD	
1002	216				216				216				216
1003	264	226	66	250	264	226	66	250	264	260	100	300	264
1004													

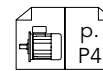
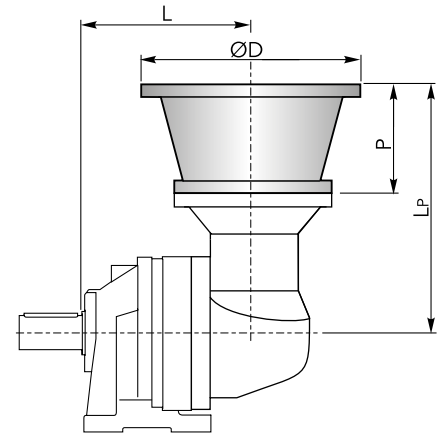

CHPLB 1000 CCPC - Alberi maschi entrata | *Male input shafts*

CHPLB	CM42				
	L	L _T	T	L _E	ØE
1002	216				
1003	264	253	93	82	42 h6
1004	312				

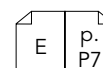
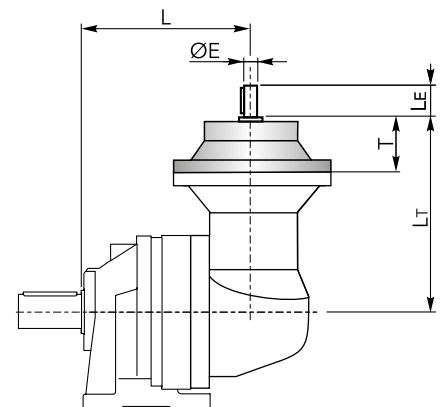

ACCESSORI · ACCESSORIES

CHYZ



Pignoni | Pinions

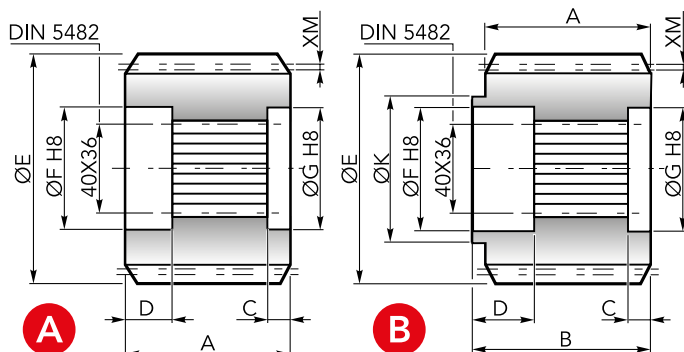

	Uscita / Output	M	Z	XM	A	B	C	D	E	F	G	K	Codice / Code
A	CMS	1.9	20	0.05	65	-	6	20.5	84.5	42	42	-	1071.200.042
	CPS	5	16	2.5	55	-	6	20.5	95	42	42	-	1071.259.042
B	CMS	3.5	23	0	40	60.5	6	20.5	87.5	42	42	60	1071.291.042

CHFF

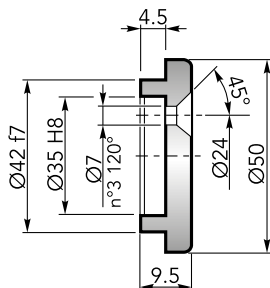

Fondello di arresto | Stop bottom plate

Codice / Code:
1075.034.000

CHBS

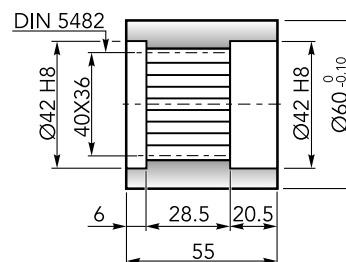

Boccola scanalata | Splined bushing

Codice / Code:
0171.100.076

CHKB

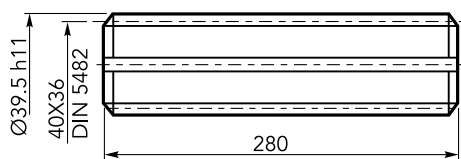

Barra scanalata | Splined rod

Codice / Code:
3071.179.042

CHFL

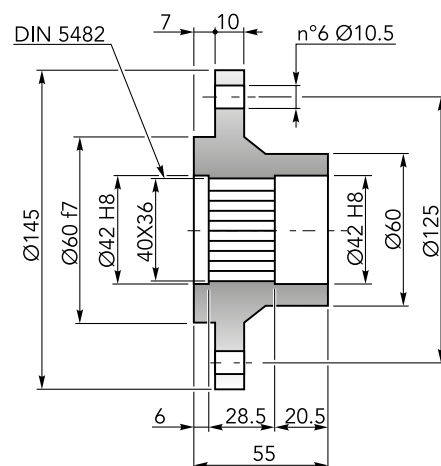

Flangia | Flange

Codice / Code:
0171.102.025

CHGA

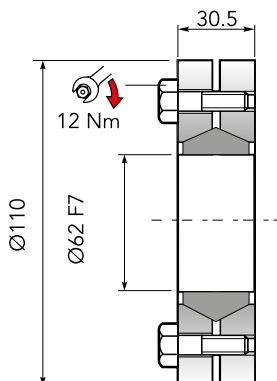

Giunto di attrito | Shrink disc

Codice / Code:
5109.062.000Coppia max: 2200 Nm (1)
Max Torque: 2200 Nm (1)(1): Coppia max indicata è valida solo con calettatori forniti da Chiaravalli S.p.A.
(1): The maximum torque indicated is valid only with shrink discs supplied by Chiaravalli S.p.A.



CARICHI RADIALI (Fr) · RADIAL LOADS (Fr)

Nel diagramma seguente, sono indicati i carichi radiali F_r (N) applicabili sull'albero uscita in funzione della distanza di applicazione L rispetto alla battuta dell'albero.

The hereunder table shows the allowable radial loads F_r (N) on the output shaft with reference to the distance L .

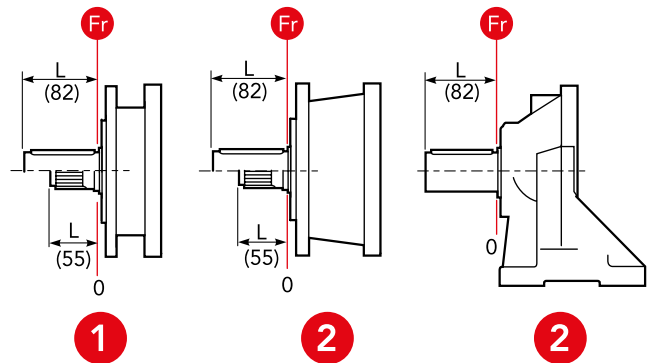
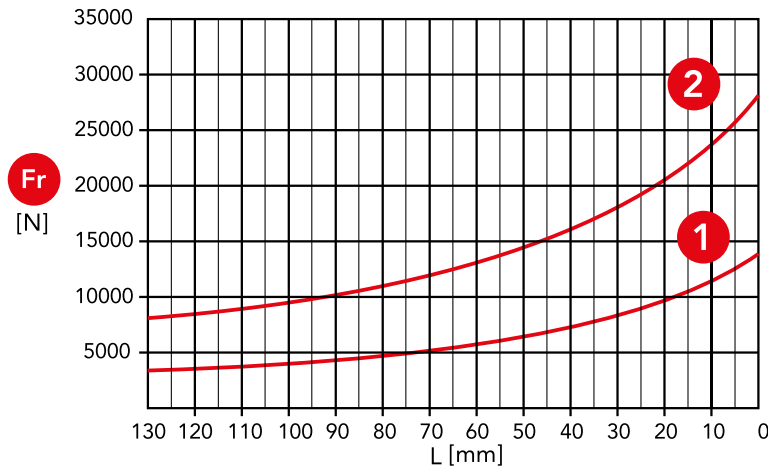

- 1 Uscita / Output: CMS, CMC
- 2 Uscita / Output: CPS, CPC, CCPC

CARICHI ASSIALI (Fa) · AXIAL LOADS (Fa)

Nella tabella seguente sono indicati i carichi assiali F_a (N) applicabili sull'albero di uscita in funzione della direzione di applicazione del carico e della versione.

The hereunder table shows the allowable axial loads F_a (N) on the output shaft with reference to the load direction and the output type.

	1	2	
F_a [N]	16000	18000	←
	16000	18000	→

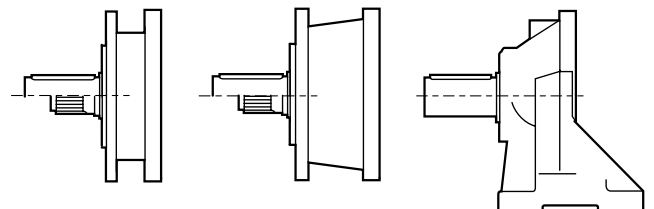

- 1 Uscita / Output: CMS, CMC
- 2 Uscita / Output: CPS, CPC, CCPC





CHPL

	i	
1601	3.56 ÷ 6.75	1 reduction stage
1602	12.6 ÷ 58.5	2 reduction stages
1603	54.2 ÷ 394.9	3 reduction stages
1604	337.4 ÷ 3422.2	4 reduction stages

OUT

IN

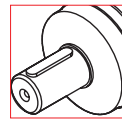

Ø42
Ø38 Ø50

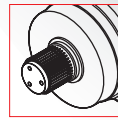

40x36
DIN 5482

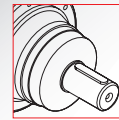

Ø42

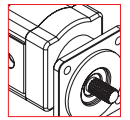

Hydraulic
Motor

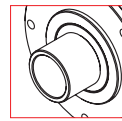

Ø50

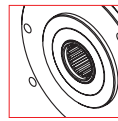

40x36
DIN 5482

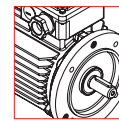

Electric
Motor

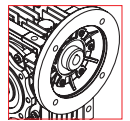

Worm
gearboxes

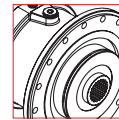

Brake

CHPLB

	i	
1602	10.4 ÷ 19.8	2 reduction stages
1603	37.1 ÷ 171.6	3 reduction stages
1604	131.8 ÷ 1487.2	4 reduction stages

OUT

IN

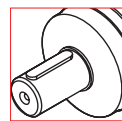

Ø42
Ø38 Ø50

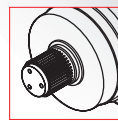

40x36
DIN 5482

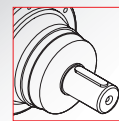

Ø42

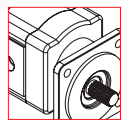

Hydraulic
Motor

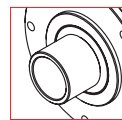

Ø50

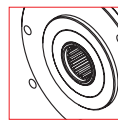

40x36
DIN 5482

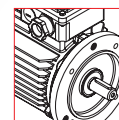

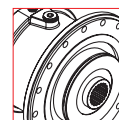

Electric
Motor

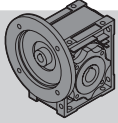

Brake

DATI TECNICI · TECHNICAL DATA

CHPL	i	T _{2n} (n ₁ = 1400 rpm) 10.000h FS=1 [Nm]	P _{1n} (n ₁ = 1400 rpm) 10.000h FS=1 [kW]	T ₂ Max [Nm]	P _t 1400 rpm [kW]	IEC			
						(B5)			
1601	3.56	697	29.70	3460	12	63	71	CHM 50 CHM 63 CHM 75	CM42
	4.29	715	25.30	3460		80	90		
	5.6	548	14.85	2460		100	112		
	6.75	463	10.50	2040		132	160		
1602	12.6	896	11.20	3460	8	63 80 100 132	71 90 112	CHM 50 CHM 63 CHM 75	CM42
	15.2	926	9.60	3460					
	19.9	948	7.50	3460					
	24	972	6.38	3460					
	28.9	1010	5.50	3460					
	31.4	748	3.75	2460					
	37.8	766	3.19	2460					
	45.6	651	2.25	2040					
	58.5	670	1.80	2040					
1603	54.2	1145	3.45	3460	5	63 80 100 132	71 90 112	CHM 50 CHM 63 CHM 75	CM42
	65.3	1188	2.97	3460					
	70.8	1193	2.75	3460					
	78.7	1221	2.53	3460					
	85.3	1208	2.31	3460					
	102.9	1277	2.03	3460					
	111.5	1282	1.88	3460					
	134.4	1314	1.60	3460					
	162	1365	1.38	3460					
	172.6	1397	1.32	3460					
	208	1472	1.16	3460					
	211.7	1008	0.78	2460					
	255.2	1056	0.68	2460					
	271.8	1043	0.63	2460					
	307.5	895	0.48	2040					
	327.6	1104	0.55	2460					
	394.9	896	0.37	2040					
1604	337.4	1550	0.78	3460	1.5	63 80	71 90	CHM 50 CHM 63 CHM 75	CM42
	365.7	1569	0.73	3460					
	396.4	1582	0.68	3460					
	440.8	1630	0.63	3460					
	477.9	1626	0.58	3460					
	531.3	1698	0.54	3460					
	576	1716	0.50	3460					
	624.4	1729	0.47	3460					
	694.3	1774	0.43	3460					
	752.6	1762	0.40	3460					
	836.9	1782	0.36	3460					
	907.2	1868	0.35	3460					
	966.3	1852	0.32	3460					
	1093.5	1940	0.30	3460					
	1144.5	1949	0.29	3460					
	1185.4	1346	0.19	2460					
	1318.1	1966	0.25	3460					
	1428.8	1420	0.17	2460					
	1692.3	2142	0.21	3460					
	3422.2	1326	0.07	2040					

n_{1max} = 2800 rpm

per ulteriori rapporti consultare l'ufficio tecnico

for information consult the technical office

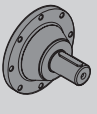

DATI TECNICI · TECHNICAL DATA

 CHPLB	i	T _{2n} (n ₁ = 1400 rpm) 10.000h FS=1 [Nm]	P _{1n} (n ₁ = 1400 rpm) 10.000h FS=1 [kW]	T ₂ Max [Nm]	P _t 1400 rpm [kW]	IEC (B5)		 CM
1602	10.4	835	12.65	3460	8	63	71	CM42
	12.6	880	11.00	3460		80	90	
	16.4	657	6.30	2460		100	112	
	19.8	566	4.50	2040		132		
1603	37.1	1050	4.62	3460	5	63	71	CM42
	44.7	1085	3.96	3460		80	90	
	53.9	1163	3.52	3460		100	112	
	58.4	1103	3.08	3460		132		
	70.4	1139	2.64	3460				
	84.9	1260	2.42	3460				
	92	931	1.65	2460				
	110.9	918	1.35	2460				
	133.6	811	0.99	2040				
	171.6	811	0.77	2040				
1604	131.8	1372	1.76	3460	1.5	63	71	CM42
	158.9	1340	1.43	3460		80	90	
	191.6	1445	1.28	3460				
	207.7	1382	1.13	3460				
	230.9	1434	1.05	3460				
	301.7	1473	0.83	3460				
	327.1	1596	0.83	3460				
	363.7	1614	0.75	3460				
	394.2	1574	0.68	3460				
	475.2	1686	0.60	3460				
	515.1	1240	0.41	2460				
	572.8	1678	0.50	3460				
	610.1	1787	0.50	3460				
	735.4	1771	0.41	3460				
	797.2	1297	0.28	2460				
	960.9	1279	0.23	2460				
	1158.3	1110	0.16	2040				
	1233.8	1460	0.20	2460				
1487.2	1267	0.15	2040					

n_{1max} = 2800 rpm

per ulteriori rapporti consultare l'ufficio tecnico

for information consult the technical office

DIMENSIONI · DIMENSIONS

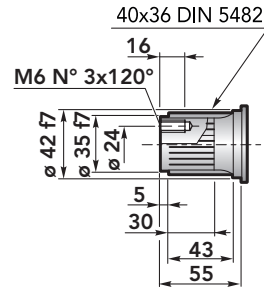
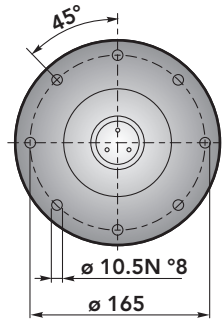
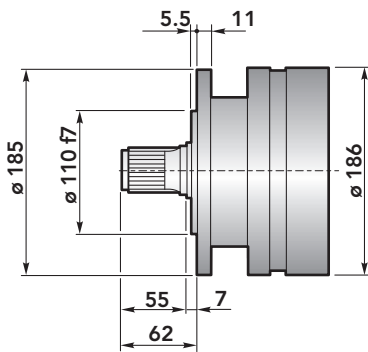

Accessori
Accessories

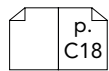

CHPL 1600 CMS - Flange motori IEC | IEC Motor flanges

CHPL	IEC 63			IEC 71			IEC 80			IEC 90		
	Lp	P	ØD	Lp	P	ØD	Lp	P	ØD	Lp	P	ØD
1601	153			153			173			173		
1602	201	36	140	201	36	160	221	56	200	221	56	200
1603	249			249			269			269		
1604	297			297			317			317		

CHPL	IEC 100			IEC 112			IEC 132			IEC 160		
	Lp	P	ØD	Lp	P	ØD	Lp	P	ØD	Lp	P	ØD
1601	183			183			217			256	139	350
1602	231	66	250	231	66	250	265	100	300	-		
1603	279			266			313			-		
1604	-			-			-					

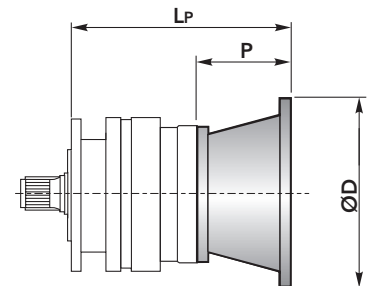

CHPL 1600 CMS - Alberi maschi entrata | Male input shafts

CHPL	CM42			
	Lt	T	Le	ØE
1601	210			
1602	258	93	82	42 h6
1603	306			
1604	354			

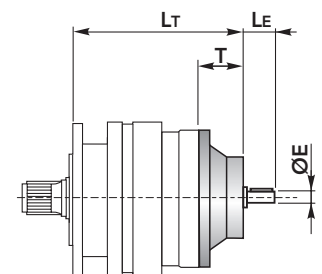



DIMENSIONI · DIMENSIONS

CHPL 1600 CMS - Riduttore a vite senza fine CHM in entrata | *CHM input worm gearboxes*

CHPL	CHM 50					CHM 63				
	Lv	I	H	M	N	Lv	I	H	M	N
1601	242.5	50	110	60	80	252	63	135	72	95
1602	290.5					300				
1603	338.5					348				
1604	386.5					396				

CHPL	CHM 75				
	Lv	I	H	M	N
1601	231	75	161	86	112.5
1602	279				
1603	327				
1604	375				

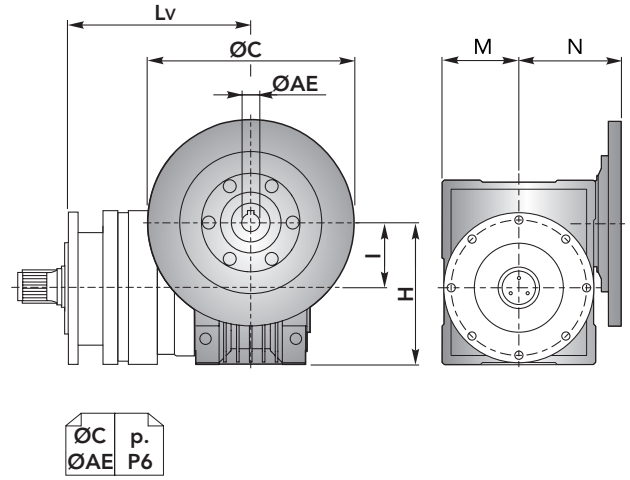

CHPL / CHPLB 1600 CMS

CHPLB 1600 CMS - Flange motori IEC | *IEC Motor flanges*

CHPLB	IEC 63				IEC 71				IEC 80				IEC 90			
	L	LP	P	ØD	L	LP	P	ØD	L	LP	P	ØD	L	LP	P	ØD
1602	192	196	36	140	192	196	36	160	192	216	56	200	192	216	56	200
1603	240				240				240							
1604	288				288				288							

CHPLB	IEC 100				IEC 112				IEC 132			
	L	LP	P	ØD	L	LP	P	ØD	L	LP	P	ØD
1602	192	226	66	250	192	226	66	250	192	260	100	300
1603	240				240				240			
1604	288				288				288			

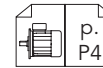
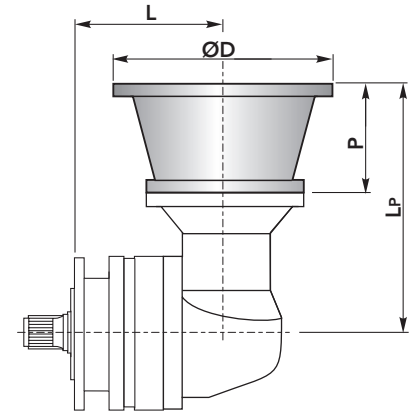

CHPLB 1600 CMS - Alberi maschi entrata | *Male input shafts*

CHPLB	CM42				
	L	LT	T	LE	ØE
1602	192	253	93	82	42 h6
1603	240				
1604	288				

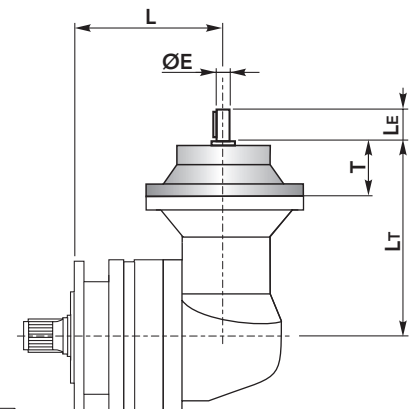

DIMENSIONI · DIMENSIONS

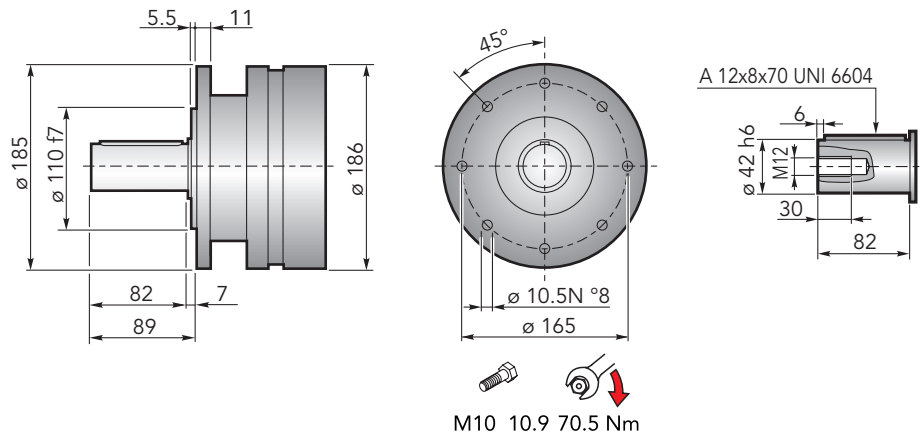

CHPL 1600 CMC - Flange motori IEC | IEC Motor flanges

CHPL	IEC 63			IEC 71			IEC 80			IEC 90		
	LP	P	ØD	LP	P	ØD	LP	P	ØD	LP	P	ØD
1601	153	36	140	153	36	160	173	56	200	173	56	200
1602	201			201			221			221		
1603	249			249			269			269		
1604	297			297			317			317		

CHPL	IEC 100			IEC 112			IEC 132			IEC 160		
	LP	P	ØD	LP	P	ØD	LP	P	ØD	LP	P	ØD
1601	183	66	250	183	66	250	217	100	300	256	139	350
1602	231			231			265			-		
1603	279			266			313			-		
1604	-			-			-			-		

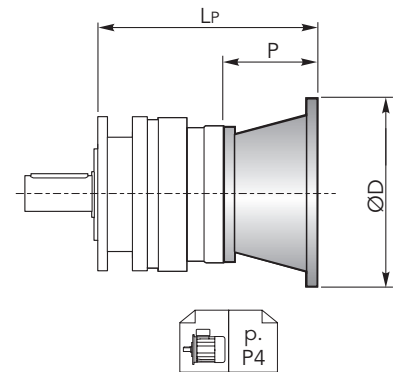

CHPL 1600 CMC - Alberi maschi entrata | Male input shafts

CHPL	CM42			
	LT	T	LE	ØE
1601	210	93	82	42 h6
1602	258			
1603	306			
1604	354			

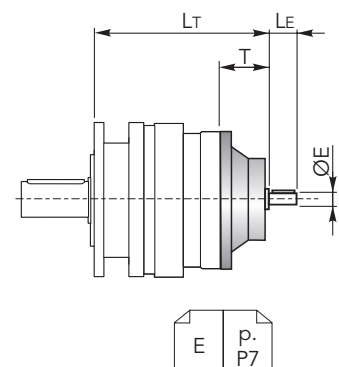



DIMENSIONI · DIMENSIONS

CHPL 1600 CMC - Riduttore a vite senza fine CHM in entrata | *CHM input worm gearboxes*

CHPL	CHM 50					CHM 63				
	Lv	I	H	M	N	Lv	I	H	M	N
1601	242.5	50	110	60	80	252	63	135	72	95
1602	290.5					300				
1603	338.5					348				
1604	386.5					396				

CHPL	CHM 75				
	Lv	I	H	M	N
1601	231	75	161	86	112.5
1602	279				
1603	327				
1604	375				

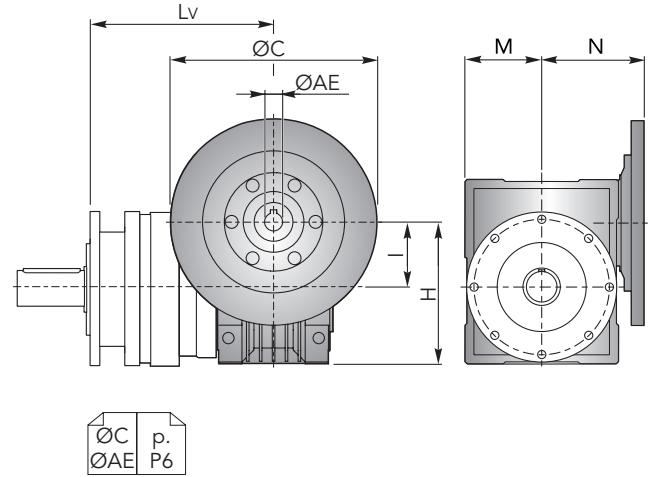

CHPL / CHPLB 1600 CMC

CHPLB 1600 CMC - Flange motori IEC | *IEC Motor flanges*

CHPLB	IEC 63				IEC 71				IEC 80				IEC 90			
	L	LP	P	ØD	L	LP	P	ØD	L	LP	P	ØD	L	LP	P	ØD
1602	192	196	36	140	192	196	36	160	192	216	56	200	192	216	56	200
1603	240				240				240							
1604	288				288				288							

CHPLB	IEC 100				IEC 112				IEC 132			
	L	LP	P	ØD	L	LP	P	ØD	L	LP	P	ØD
1602	192	226	66	250	192	226	66	250	192	260	100	300
1603	240				240				240			
1604	288				288				288			

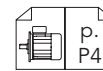
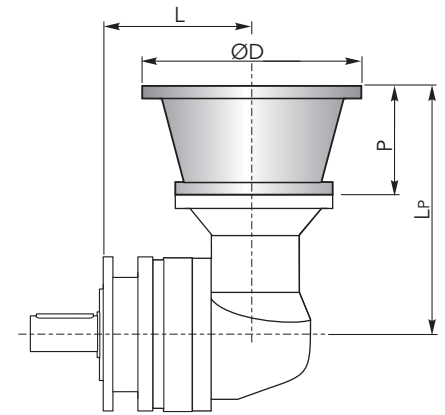

CHPLB 1600 CMC - Alberi maschi entrata | *Male input shafts*

CHPLB	CM42				
	L	LT	T	LE	ØE
1602	192	253	93	82	42 h6
1603	240				
1604	288				

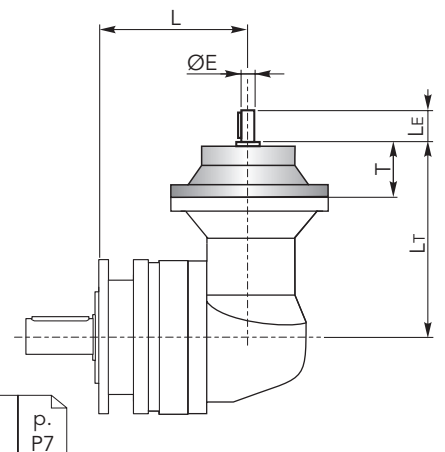

DIMENSIONI · DIMENSIONS

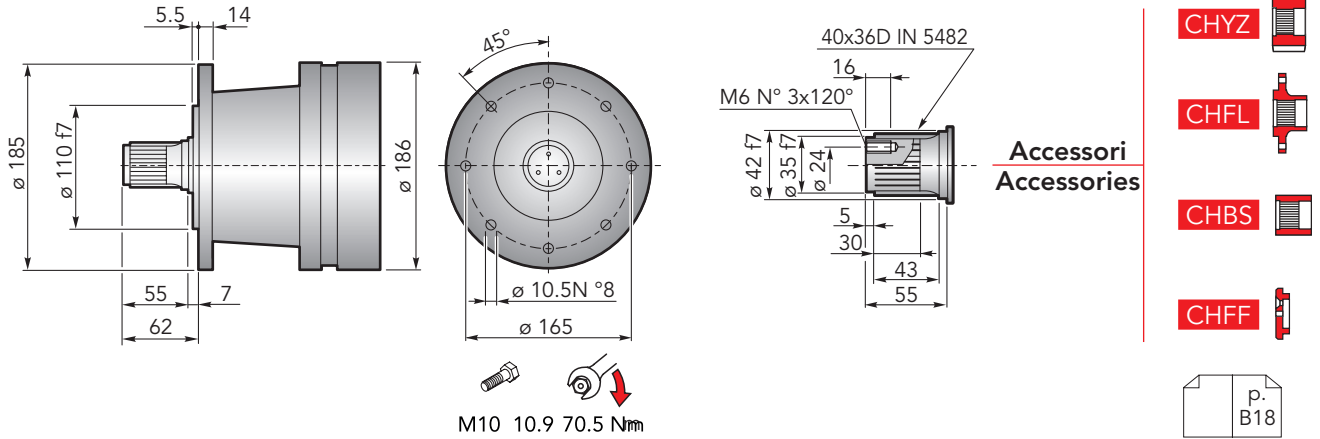

CHPL 1600 CPS - Flange motori IEC | IEC Motor flanges

CHPL	IEC 63			IEC 71			IEC 80			IEC 90			
	LP	P	ØD	LP	P	ØD	LP	P	ØD	LP	P	ØD	
1601	183			183			203			203			
1602	231	36	140	231	36	160	251	56	200	251	56	200	
1603	279			279						299			299
1604	327			327						347			347
CHPL	IEC 100			IEC 112			IEC 132			IEC 160			
	LP	P	ØD	LP	P	ØD	LP	P	ØD	LP	P	ØD	
1601	213			213			247			286	139	350	
1602	261	66	250	261	66	250	295	100	300	-	-	-	
1603	309			309			343			-	-	-	
1604	-			-			-			-	-	-	

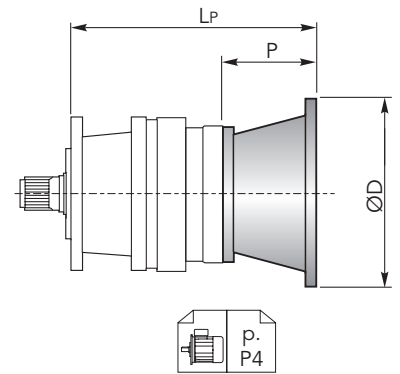

CHPL 1600 CPS - Alberi maschi entrata | Male input shafts

CHPL	CM42			
	LT	T	LE	ØE
1601	240	93	82	42 h6
1602	288			
1603	336			
1604	384			

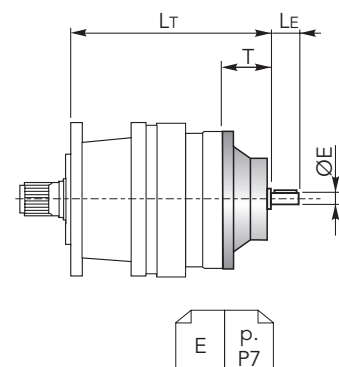



DIMENSIONI · DIMENSIONS

CHPL 1600 CPS - Riduttore a vite senza fine CHM in entrata | *CHM input worm gearboxes*

CHPL	CHM 50					CHM 63				
	Lv	I	H	M	N	Lv	I	H	M	N
1601	272.5	50	110	60	80	282	63	135	72	95
1602	320.5					330				
1603	368.5					378				
1604	416.5					426				

CHPL	CHM 75				
	Lv	I	H	M	N
1601	261	75	161	86	112.5
1602	309				
1603	357				
1604	405				

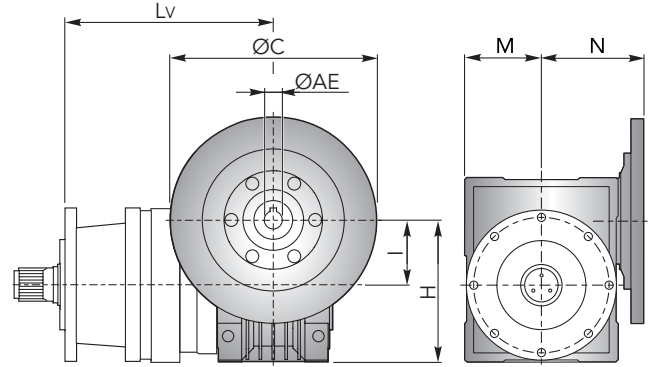

CHPLB 1600 CPS - Flange motori IEC | *IEC Motor flanges*

CHPLB	IEC 63				IEC 71				IEC 80				IEC 90			
	L	LP	P	ØD	L	LP	P	ØD	L	LP	P	ØD	L	LP	P	ØD
1602	222	196	36	140	222	196	36	160	222	216	56	200	222	216	56	200
1603	270				270				270							
1604	318				318				318							

CHPLB	IEC 100				IEC 112				IEC 132			
	L	LP	P	ØD	L	LP	P	ØD	L	LP	P	ØD
1602	222	226	66	250	222	226	66	250	222	260	100	300
1603	270				270				270			
1604												

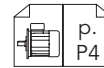
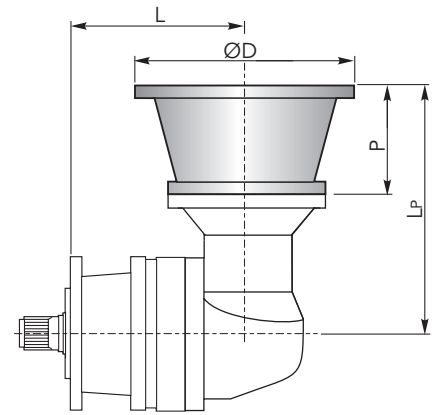

CHPLB 1600 CPS - Alberi maschi entrata | *Male input shafts*

CHPLB	CM42				
	L	Lt	T	Le	ØE
1602	222	253	93	82	42 h6
1603	270				
1604	318				

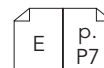
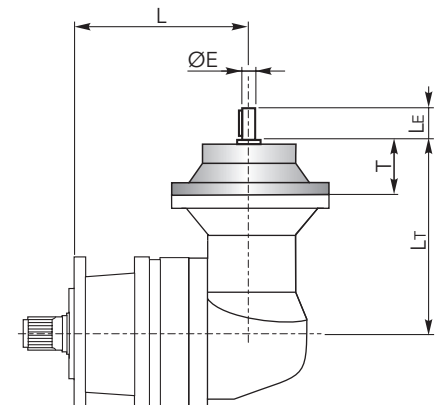

CHPL / CHPLB 1600 CPS

DIMENSIONI · DIMENSIONS

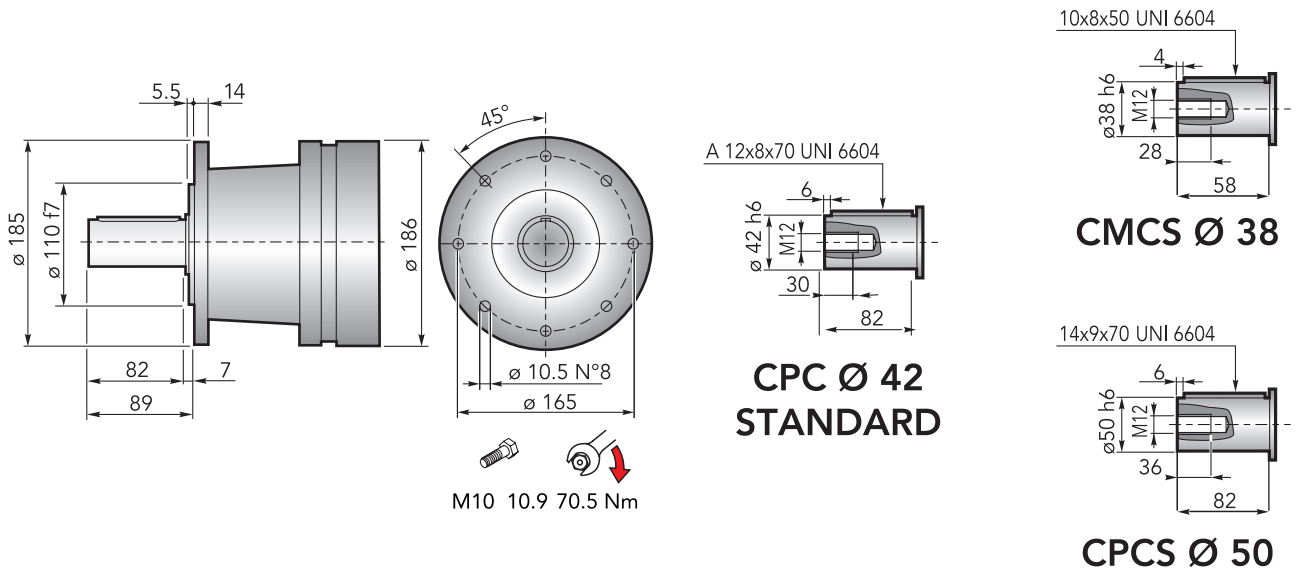

CHPL 1600 CPC - Flange motori IEC | IEC Motor flanges

CHPL	IEC 63			IEC 71			IEC 80			IEC 90		
	LP	P	ØD	LP	P	ØD	LP	P	ØD	LP	P	ØD
1601	183			183			203			203		
1602	231	36	140	231	36	160	251	56	200	251	56	200
1603	279			279								
1604	327			327								
CHPL	IEC 100			IEC 112			IEC 132			IEC 160		
	LP	P	ØD	LP	P	ØD	LP	P	ØD	LP	P	ØD
1601	213			213			247			286	139	350
1602	261	66	250	261	66	250	295	100	300	-		
1603	309			309			-					
1604	-			-			-					

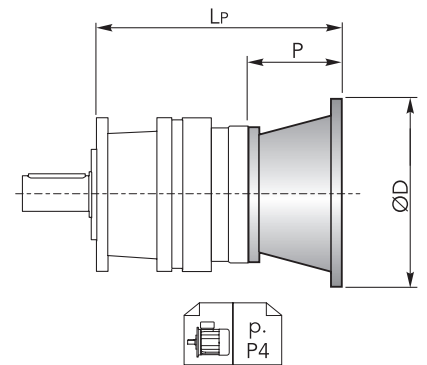

CHPL 1600 CPC - Alberi maschi entrata | Male input shafts

CHPL	CM42			
	LT	T	LE	ØE
1601	240			
1602	288	93	82	42 h6
1603	336			
1604	384			

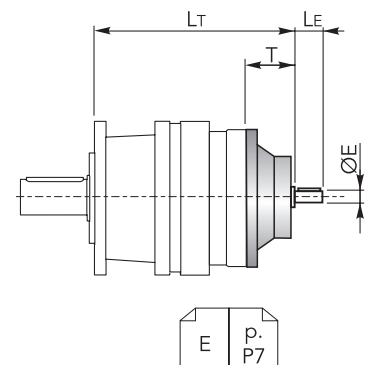



DIMENSIONI · DIMENSIONS

CHPL 1600 CPC - Riduttore a vite senza fine CHM in entrata | *CHM input worm gearboxes*

CHPL	CHM 50					CHM 63				
	Lv	I	H	M	N	Lv	I	H	M	N
1601	272.5	50	110	60	80	282	63	135	72	95
1602	320.5					330				
1603	368.5					378				
1604	416.5					426				

CHPL	CHM 75				
	Lv	I	H	M	N
1601	261	75	161	86	112.5
1602	309				
1603	357				
1604	405				

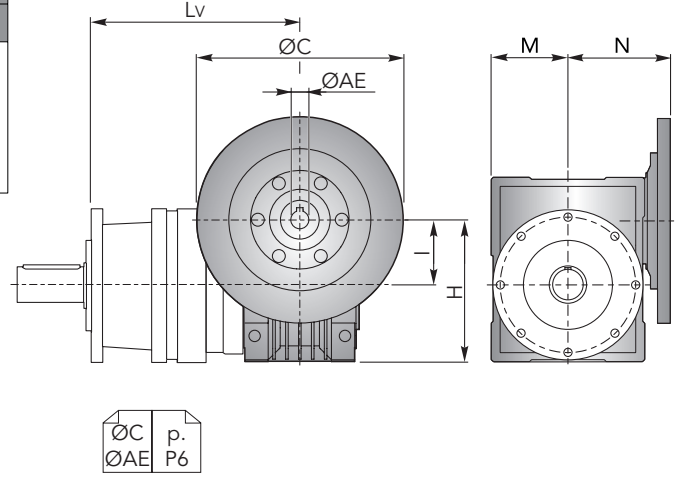

CHPL / CHPLB 1600 CPC

CHPLB 1600 CPC - Flange motori IEC | *IEC Motor flanges*

CHPLB	IEC 63				IEC 71				IEC 80				IEC 90			
	L	LP	P	ØD	L	LP	P	ØD	L	LP	P	ØD	L	LP	P	ØD
1602	222	196	36	140	222	196	36	160	222	216	56	200	222	216	56	200
1603	270				270				270							
1604	318				318				318							

CHPLB	IEC 100				IEC 112				IEC 132			
	L	LP	P	ØD	L	LP	P	ØD	L	LP	P	ØD
1602	222	226	66	250	222	226	66	250	222	260	100	300
1603	270				270				270			
1604												

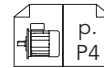
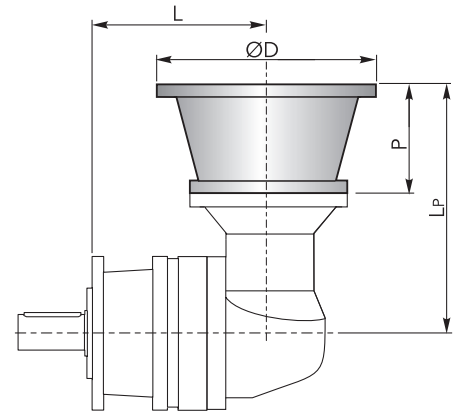

CHPLB 1600 CPC - Alberi maschi entrata | *Male input shafts*

CHPLB	CM42				
	L	L _T	T	L _E	ØE
1602	222	253	93	82	42 h6
1603	270				
1604	318				

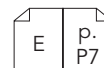
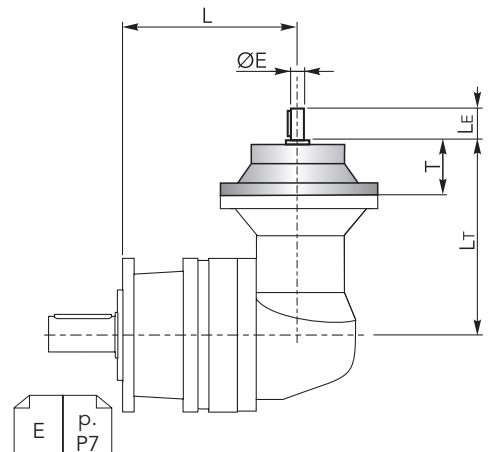

DIMENSIONI · DIMENSIONS

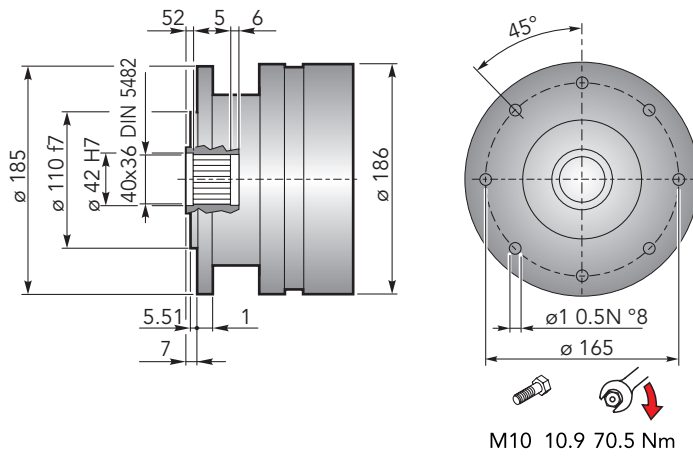

Accessori
Accessories

CHKB

p.
C18

CHPL 1600 CF - Flange motori IEC | IEC Motor flanges

CHPL	IEC 63			IEC 71			IEC 80			IEC 90			
	Lp	P	ØD	Lp	P	ØD	Lp	P	ØD	Lp	P	ØD	
1601	153			153			173			173			
1602	201	36	140	201	36	160	221	56	200	221	56	200	
1603	249			249									269
1604	297			297									317

CHPL	IEC 100			IEC 112			IEC 132			IEC 160		
	Lp	P	ØD	Lp	P	ØD	Lp	P	ØD	Lp	P	ØD
1601	183			183			217			256	139	350
1602	231	66	250	231	66	250	265	100	300	-		
1603	279			266			313			-		
1604	-			-			-			-		

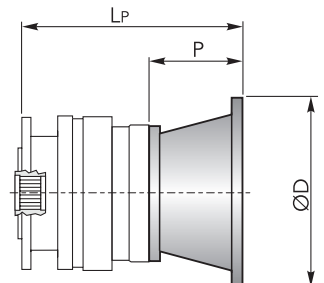

p.
P4

CHPL 1600 CF - Alberi maschi entrata | Male input shafts

CHPL	CM42			
	Lt	T	LE	ØE
1601	210			
1602	258	93	82	42 h6
1603	306			
1604	354			

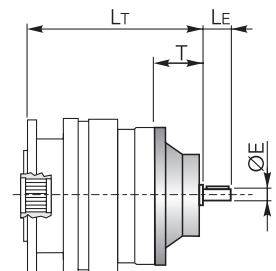

E
p.
P7



DIMENSIONI · DIMENSIONS

CHPL 1600 CF - Riduttore a vite senza fine CHM in entrata | *CHM input worm gearboxes*

CHPL	CHM 50					CHM 63				
	Lv	I	H	M	N	Lv	I	H	M	N
1601	242.5	50	110	60	80	252	63	135	72	95
1602	290.5					300				
1603	338.5					348				
1604	386.5					396				

CHPL	CHM 75				
	Lv	I	H	M	N
1601	231	75	161	86	112.5
1602	279				
1603	327				
1604	375				

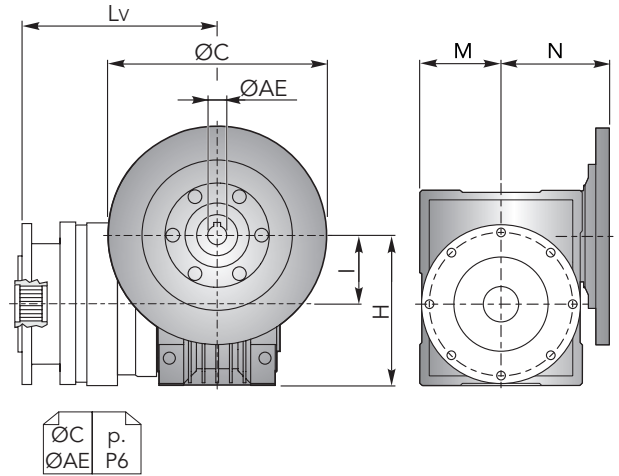

CHPL / CHPLB 1600 CF

CHPLB 1600 CF - Flange motori IEC | *IEC Motor flanges*

CHPLB	IEC 63				IEC 71				IEC 80				IEC 90						
	L	LP	P	ØD	L	LP	P	ØD	L	LP	P	ØD	L	LP	P	ØD			
1602	192	196	36	140	192	196	36	160	192	216	56	200	192	216	56	200			
1603	240				240				240				240				240	240	240
1604	288				288				288				288				288	288	288

CHPLB	IEC 100				IEC 112				IEC 132				
	L	LP	P	ØD	L	LP	P	ØD	L	LP	P	ØD	
1602	192	226	66	250	192	226	66	250	192	260	100	300	
1603	240				240				240				240
1604	288				288				288				288

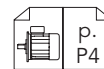
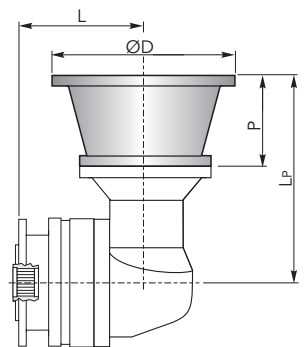

CHPLB 1600 CF - Alberi maschi entrata | *Male input shafts*

CHPLB	CM42				
	L	LT	T	LE	ØE
1602	192	253	93	82	42 h6
1603	240				
1604	288				

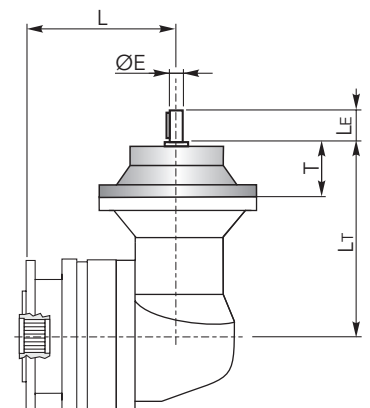

DIMENSIONI · DIMENSIONS

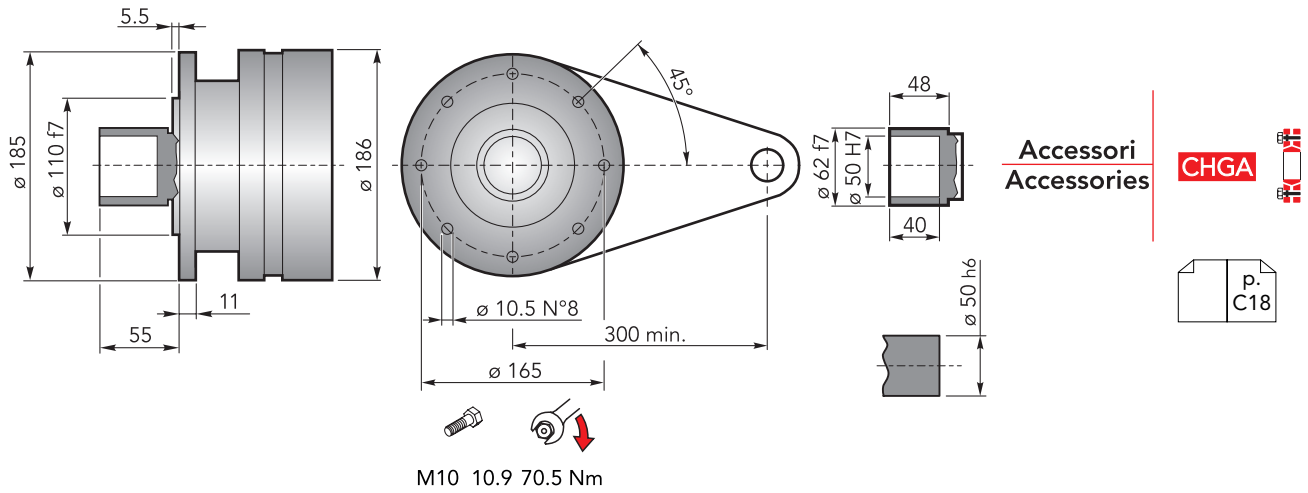

CHPL 1600 CFS - Flange motori IEC | IEC Motor flanges

CHPL	IEC 63			IEC 71			IEC 80			IEC 90		
	LP	P	ØD	LP	P	ØD	LP	P	ØD	LP	P	ØD
1601	153			153			173			173		
1602	201	36	140	201	36	160	221	56	200	221	56	200
1603	249			249			269			269		
1604	297			297			317			317		

CHPL	IEC 100			IEC 112			IEC 132			IEC 160		
	LP	P	ØD	LP	P	ØD	LP	P	ØD	LP	P	ØD
1601	183			183			217			256	139	350
1602	231	66	250	231	66	250	265	100	300	-		
1603	279			266			313			-		
1604	-			-			-					

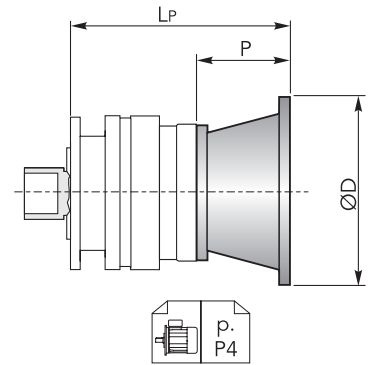

CHPL 1600 CFS - Alberi maschi entrata | Male input shafts

CHPL	CM42			
	LT	T	LE	ØE
1601	210			
1602	258	93	82	42 h6
1603	306			
1604	354			

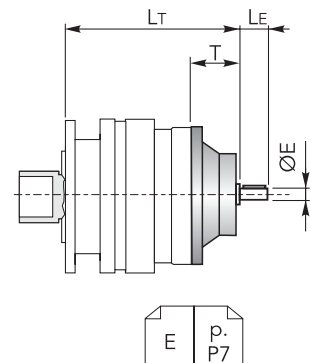



DIMENSIONI · DIMENSIONS

CHPL 1600 CFS - Riduttore a vite senza fine CHM in entrata | *CHM input worm gearboxes*

CHPL	CHM 50					CHM 63				
	Lv	I	H	M	N	Lv	I	H	M	N
1601	242.5	50	110	60	80	252	63	135	72	95
1602	290.5					300				
1603	338.5					348				
1604	386.5					396				

CHPL	CHM 75				
	Lv	I	H	M	N
1601	231	75	161	86	112.5
1602	279				
1603	327				
1604	375				

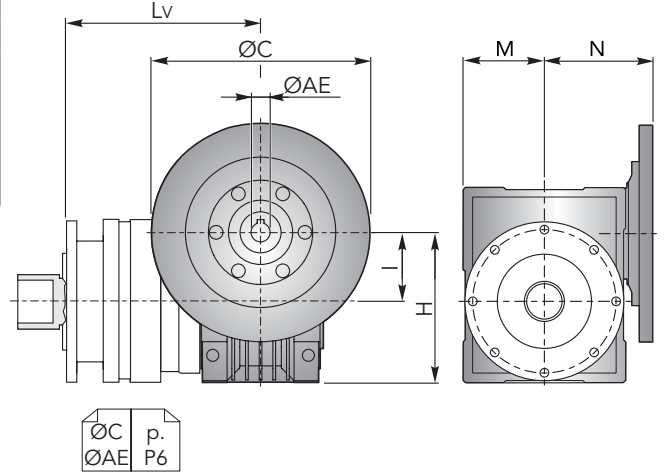

CHPL / CHPLB 1600 CFS

CHPLB 1600 CFS - Flange motori IEC | *IEC Motor flanges*

CHPLB	IEC 63				IEC 71				IEC 80				IEC 90						
	L	LP	P	ØD	L	LP	P	ØD	L	LP	P	ØD	L	LP	P	ØD			
1602	192	196	36	140	192	196	36	160	192	216	56	200	192	216	56	200			
1603	240				240				240				240				240	240	240
1604	288				288				288				288				288	288	288

CHPLB	IEC 100				IEC 112				IEC 132				
	L	LP	P	ØD	L	LP	P	ØD	L	LP	P	ØD	
1602	192	226	66	250	192	226	66	250	192	260	100	300	
1603	240				240				240				240
1604													

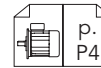
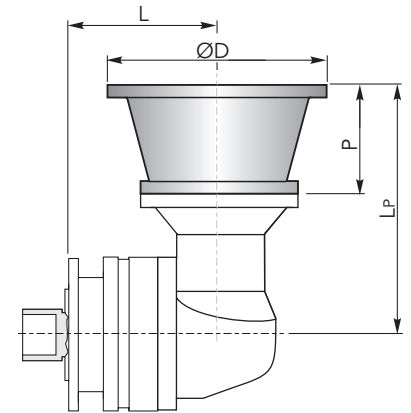

CHPLB 1600 CFS - Alberi maschi entrata | *Male input shafts*

CHPLB	CM42				
	L	LT	T	LE	ØE
1602	192	253	93	82	42 h6
1603	240				
1604	288				

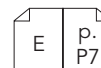
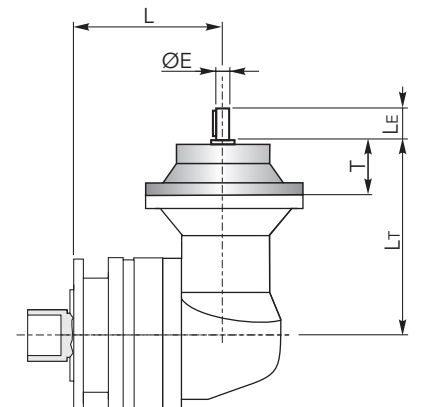

DIMENSIONI · DIMENSIONS

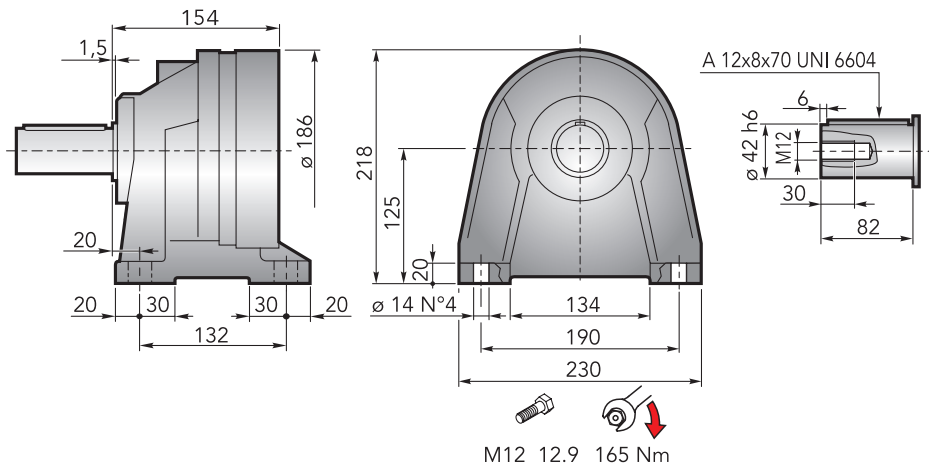

CHPL 1600 CCPC - Flange motori IEC | IEC Motor flanges

CHPL	IEC 63			IEC 71			IEC 80			IEC 90		
	LP	P	ØD	LP	P	ØD	LP	P	ØD	LP	P	ØD
1601	190			190			210			210		
1602	238	36	140	238	36	160	258	56	200	258	56	200
1603	286			286			306			306		
1604	334			334			354			354		

CHPL	IEC 100			IEC 112			IEC 132			IEC 160		
	LP	P	ØD	LP	P	ØD	LP	P	ØD	LP	P	ØD
1601	220			220			254			293	139	350
1602	268	66	250	268	66	250	302	100	300			
1603	316			316			350					
1604												

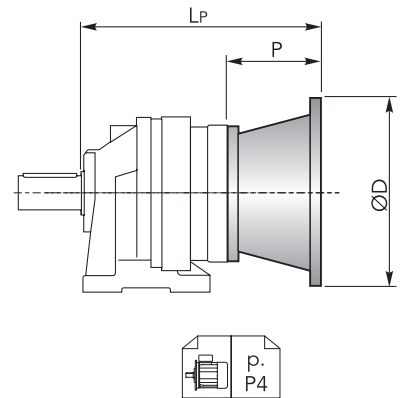

CHPL 1600 CCPC - Alberi maschi entrata | Male input shafts

CHPL	CM42			
	LT	T	LE	ØE
1601	247	93	82	42 h6
1602	295			
1603	343			
1604	391			

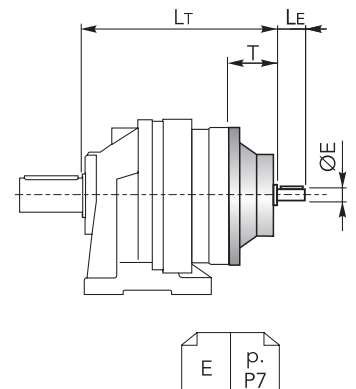



DIMENSIONI · DIMENSIONS

CHPL 1600 CCPC - Riduttore a vite senza fine CHM in entrata | *CHM input worm gearboxes*

CHPL	CHM 50					CHM 63				
	Lv	I	H	M	N	Lv	I	H	M	N
1601	279.5	50	110	60	80	289	63	135	72	95
1602	327.5					337				
1603	375.5					385				
1604	423.5					433				

CHPL	CHM 75				
	Lv	I	H	M	N
1601	268	75	161	86	112.5
1602	316				
1603	364				
1604	412				

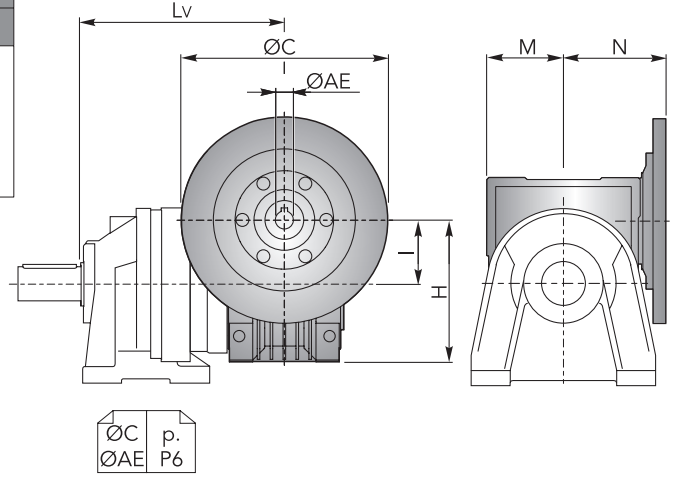

CHPL / CHPLB 1600 CCPC

CHPLB 1600 CCPC - Flange motori IEC | *IEC Motor flanges*

CHPLB	IEC 71				IEC 71				IEC 80				IEC 90			
	L	Lp	P	ØD	L	Lp	P	ØD	L	Lp	P	ØD	L	Lp	P	ØD
1602	229	196	36	140	229	196	36	160	229	216	56	200	229	216	56	200
1603	277				277				277							
1604	325				325				325							

CHPLB	IEC 100				IEC 112				IEC 132			
	L	Lp	P	ØD	L	Lp	P	ØD	L	Lp	P	ØD
1602	229	226	66	250	229	226	66	250	229	260	100	300
1603	277				277				277			
1604	-				-				-			

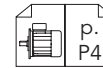
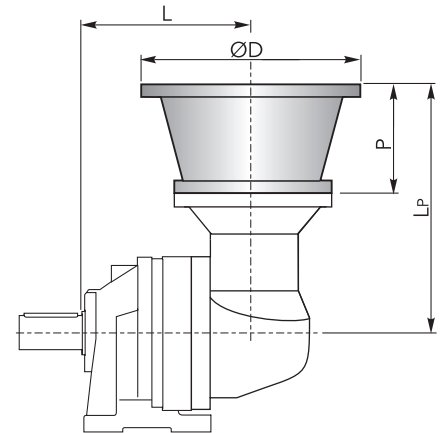

CHPLB 1600 CCPC - Alberi maschi entrata | *Male input shafts*

CHPLB	CM42				
	L	Lt	T	Le	ØE
1602	229	253	93	82	42 h6
1603	277				
1604	325				

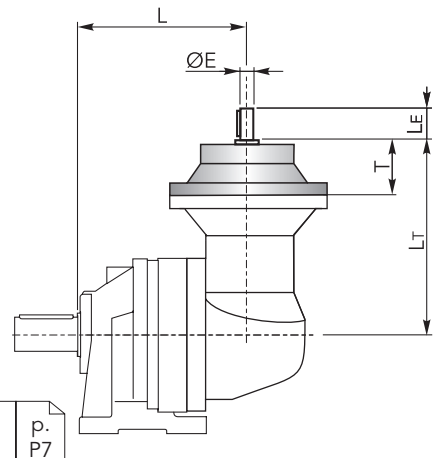

ACCESSORI · ACCESSORIES

CHYZ



Pignoni | Pinions

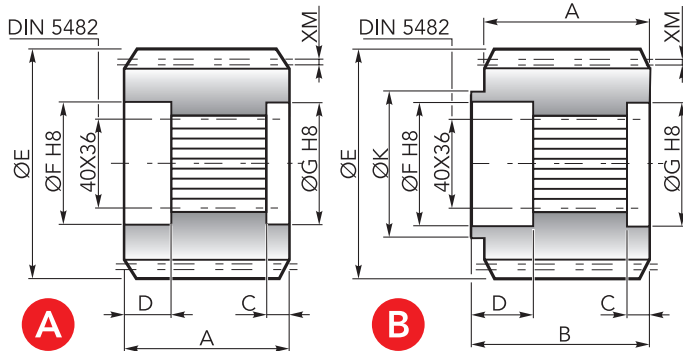

	Uscita / Output	M	Z	XM	A	B	C	D	E	F	G	K	Codice / Code
A	CMS	1.9	20	0.05	65	-	6	20.5	84.5	42	42	-	1071.200.042
	CPS	5	16	2.5	55	-	6	20.5	95	42	42	-	1071.259.042
B	CMS	3.5	23	0	40	60.5	6	20.5	87.5	42	42	60	1071.291.042

CHFF

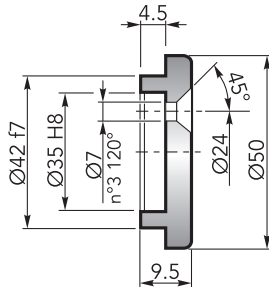

Fondello di arresto | Stop bottom plate

Codice / Code:
1075.034.000

CHBS

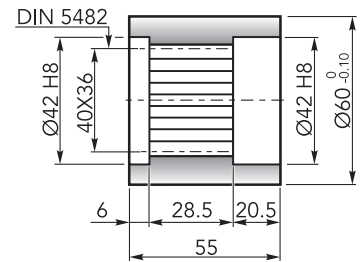

Boccola scanalata | Splined bushing

Codice / Code:
0171.100.076

CHKB

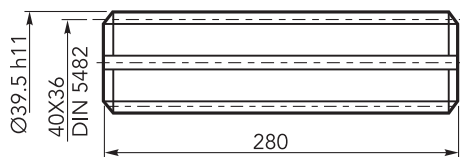

Barra scanalata | Splined rod

Codice / Code:
3071.179.042

CHFL

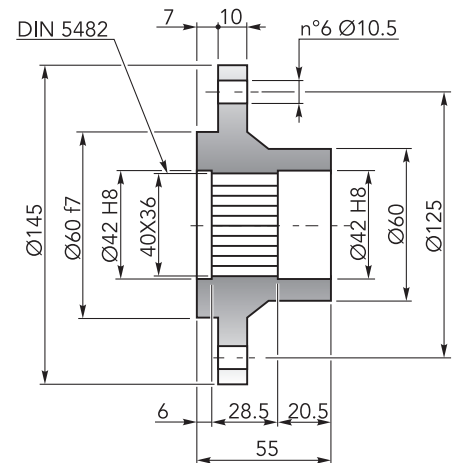

Flangia | Flange

Codice / Code:
0171.102.025

CHGA

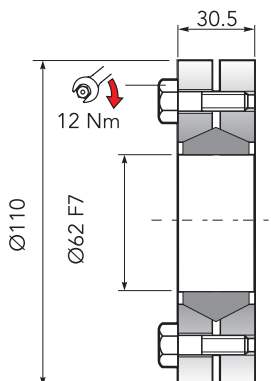

Giunto di attrito | Shrink disc

Codice / Code:
5109.062.000Coppia max: 2200 Nm (1)
Max Torque: 2200 Nm (1)(1): Coppia max indicata è valida solo con calettatori forniti da Chiaravalli S.p.A.
(1): The maximum torque indicated is valid only with shrink discs supplied by Chiaravalli S.p.A.



CARICHI RADIALI (Fr) · RADIAL LOADS (Fr)

Nel diagramma seguente, sono indicati i carichi radiali F_r (N) applicabili sull'albero uscita in funzione della distanza di applicazione L rispetto alla battuta dell'albero.

The hereunder table shows the allowable radial loads F_r (N) on the output shaft with reference to the distance L .

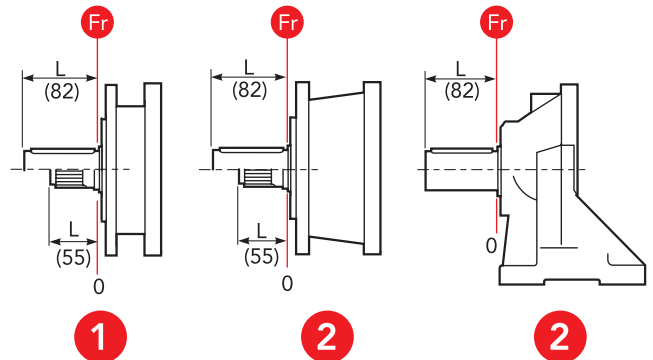
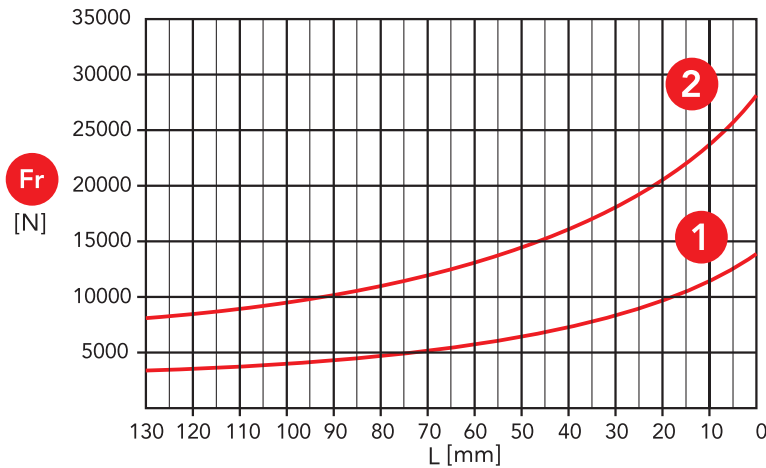

- 1** Uscita / Output: CMS, CMC
- 2** Uscita / Output: CPS, CPC, CCPC

CARICHI ASSIALI (Fa) · AXIAL LOADS (Fa)

Nella tabella seguente sono indicati i carichi assiali F_a (N) applicabili sull'albero di uscita in funzione della direzione di applicazione del carico e della versione.

The hereunder table shows the allowable axial loads F_a (N) on the output shaft with reference to the load direction and the output type.

	1	2	
F_a [N]	16000	18000	←
	16000	18000	→

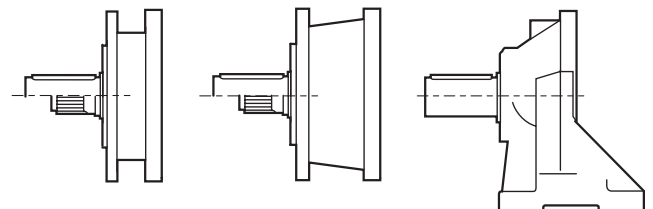

- 1** Uscita / Output: CMS, CMC
- 2** Uscita / Output: CPS, CPC, CCPC

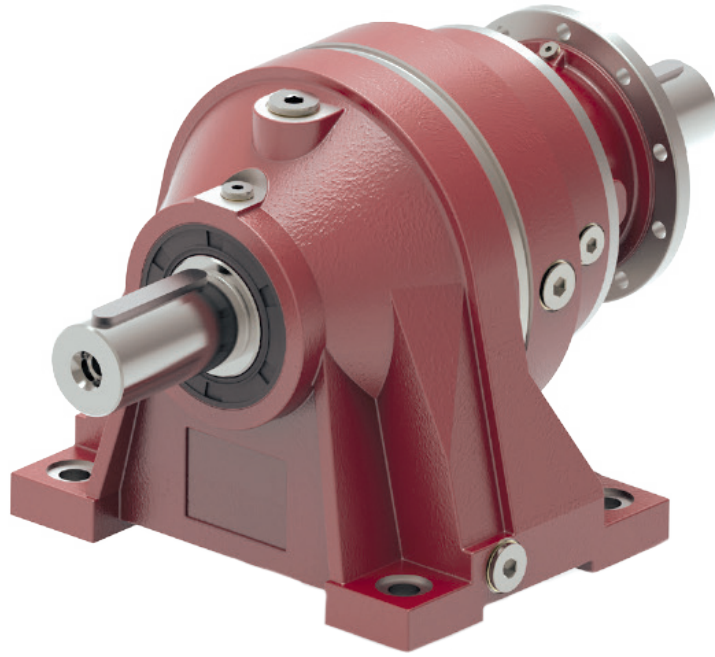



CHPL

	i	
2501	3.78 ÷ 7.25	1 reduction stage
2502	13.4 ÷ 62.8	2 reduction stages
2503	52.1 ÷ 424.1	3 reduction stages
2504	352.0 ÷ 2369.2	4 reduction stages

OUT

IN

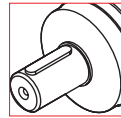

Ø65
Ø60

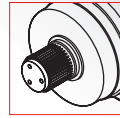

58x53
DIN 5482

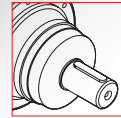

Ø42
Ø65

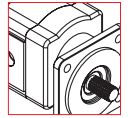

Hydraulic
Motor

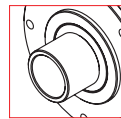

Ø75

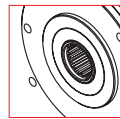

58x53
DIN 5482

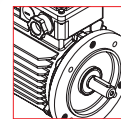

Electric
Motor

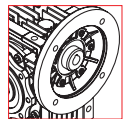

Worm
gearboxes

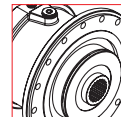

Brake

CHPLB

	i	
2502	12.1 ÷ 21.3	2 reduction stages
2503	39.4 ÷ 143.5	3 reduction stages
2504	140.1 ÷ 1244.1	4 reduction stages

OUT

IN

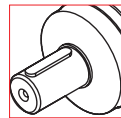

Ø65
Ø60

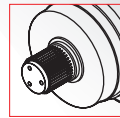

58x53
DIN 5482

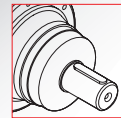

Ø42
Ø65

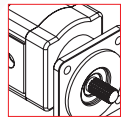

Hydraulic
Motor

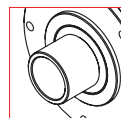

Ø75

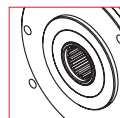

58x53
DIN 5482

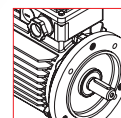

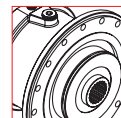

Electric
Motor

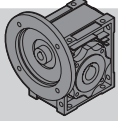

Brake

DATI TECNICI · TECHNICAL DATA

CHPL	i	T _{2n} (n ₁ = 1400 rpm) 10.000h FS=1 [Nm]	P _{1n} (n ₁ = 1400 rpm) 10.000h FS=1 [kW]	T ₂ Max [Nm]	P _t 1400 rpm [kW]	IEC		 CHM	 CM/CP	
						(B5)				
2501	3.78	1447	59.4	7180	20	63	71	CHM 50 CHM 75	CHM 63 CHM 90	CM42 CM65 CP 65
	4.13	1359	49.95	6500		80	90			
	5.17	1173	34.5	5420		100	112			
	6	1017	25.76	4540		132	160			
	7.25	823	17.25	3520		180				
2502	13.4	1851	21.75	7180	12	63	71	CHM 50 CHM 75	CHM 63 CHM 90	CM42
	16.2	1930	18.75	7180		80	90			
	18.4	1479	12.65	5420		100	112			
	23.1	1857	12.65	6500		132	160			
	28.9	1598	8.7	5420						
	34.9	1663	7.5	5420						
	40.5	1415	5.5	4540						
	48.9	1165	3.75	3520						
62.8	1186	2.97	3520							
2503	52.1	2109	6.6	6500	8	63	71	CHM 50 CHM 75	CHM 63 CHM 90	CM42
	57.6	2330	6.6	7180		80	90			
	62.9	2205	5.72	6500		100	112			
	75.2	2535	5.5	7180		132				
	82.1	2265	4.5	6500						
	90.7	2569	4.62	7180						
	99	2366	3.9	6500						
	119.3	2524	3.45	6500						
	129.4	2445	3.08	6500						
	149.5	2117	2.31	5420						
	155.9	2523	2.64	6500						
	162	2161	2.17	5420						
	173.6	1836	1.72	4540						
	195.3	2245	1.87	5420						
	235.4	2303	1.59	5420						
	273.4	1937	1.15	4540						
	302.2	2344	1.26	5420						
330.3	1573	0.77	3520							
424.1	1170	0.45	3520							
2504	352	2977	1.43	6500	4	63	71	CHM 50 CHM 75	CHM 63 CHM 90	CM 42
	365.8	2403	1.11	5420		80	90			
	388.6	3287	1.43	7180		100	112			
	413.9	3368	1.38	7180						
	424.3	3036	1.21	6500						
	468.4	3353	1.21	7180						
	511.4	3134	1.04	6500						
	554.4	3154	0.96	6500						
	612	3616	1.0	7180						
	668.2	3217	0.82	6500						
	737.7	3715	0.85	7180						
	805.5	3335	0.70	6500						
	858	3427	0.68	6500						
	907.3	2898	0.54	5420						
	1052.5	3579	0.58	6500						
	1121.1	3582	0.55	6500						
	1318.3	3089	0.40	5420						
	1589	3159	0.34	5420						
1845.3	2751	0.25	4540							
2369.2	2860	0.21	4540							

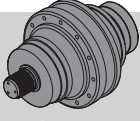
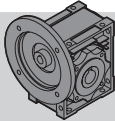
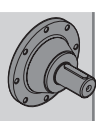

DATI TECNICI · TECHNICAL DATA

 CHPL	i	T_{2n} ($n_1 = 1400$ rpm) 10.000h FS=1 [Nm]	P_{1n} ($n_1 = 1400$ rpm) 10.000h FS=1 [kW]	T_2 Max [Nm]	P_t 1400 rpm [kW]	IEC		 CHM	 CM/CP
						(B5)			
2501	3.78	1447	59.4	7180	20	63	71	CHM 50 CHM 63 CHM 75 CHM 90	CM42 CM65 CP 65
	4.13	1359	49.95	6500		80	90		
	5.17	1173	34.5	5420		100	112		
	6	1017	25.76	4540		132	160		
	7.25	823	17.25	3520		180			
2502	13.4	1851	21.75	7180	12	63	71	CHM 50 CHM 63 CHM 75 CHM 90	CM42
	16.2	1930	18.75	7180		80	90		
	18.4	1479	12.65	5420		100	112		
	23.1	1857	12.65	6500		132	160		
	28.9	1598	8.7	5420					
	34.9	1663	7.5	5420					
	40.5	1415	5.5	4540					
	48.9	1165	3.75	3520					
62.8	1186	2.97	3520						
2503	52.1	2109	6.6	6500	8	63	71	CHM 50 CHM 63 CHM 75 CHM 90	CM42
	57.6	2330	6.6	7180		80	90		
	62.9	2205	5.72	6500		100	112		
	75.2	2535	5.5	7180		132			
	82.1	2265	4.5	6500					
	90.7	2569	4.62	7180					
	99	2366	3.9	6500					
	119.3	2524	3.45	6500					
	129.4	2445	3.08	6500					
	149.5	2117	2.31	5420					
	155.9	2523	2.64	6500					
	162	2161	2.17	5420					
	173.6	1836	1.72	4540					
	195.3	2245	1.87	5420					
	235.4	2303	1.59	5420					
	273.4	1937	1.15	4540					
	302.2	2344	1.26	5420					
330.3	1573	0.77	3520						
424.1	1170	0.45	3520						
2504	352	2977	1.43	6500	4	63	71	CHM 50 CHM 63 CHM 75 CHM 90	CM 42
	365.8	2403	1.11	5420		80	90		
	388.6	3287	1.43	7180		100	112		
	413.9	3368	1.38	7180					
	424.3	3036	1.21	6500					
	468.4	3353	1.21	7180					
	511.4	3134	1.04	6500					
	554.4	3154	0.96	6500					
	612	3616	1.0	7180					
	668.2	3217	0.82	6500					
	737.7	3715	0.85	7180					
	805.5	3335	0.70	6500					
	858	3427	0.68	6500					
	907.3	2898	0.54	5420					
	1052.5	3579	0.58	6500					
	1121.1	3582	0.55	6500					
	1318.3	3089	0.40	5420					
	1598	3159	0.34	5420					
	1845.3	2751	0.25	4540					
2369.2	2860	0.21	4540						

CHPLB 2500

DIMENSIONI · DIMENSIONS

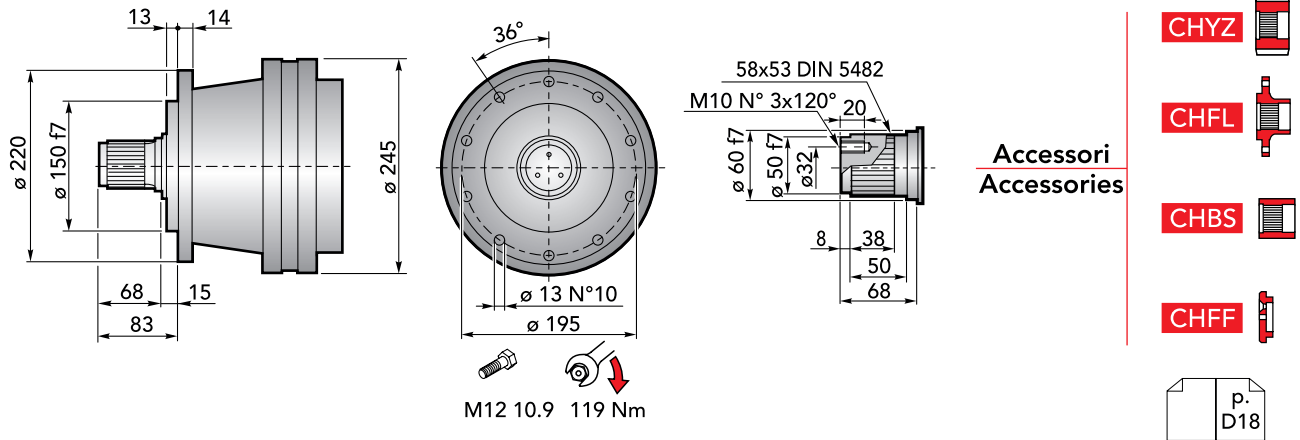

CHPL 2500 CMS - Flange motori IEC | IEC Motor flanges

CHPL	IEC 63			IEC 71			IEC 80			IEC 90			IEC 100		
	LP	P	ØD	LP	P	ØD	LP	P	ØD	LP	P	ØD	LP	P	ØD
2501	201			201			221			221			231		
2502	249	36	140	249	36	160	269	56	200	269	56	200	279	66	250
2503	297			297			317			317			327		
2504	345			345			365			365			375		

CHPL	IEC 112			IEC 132			IEC 160			IEC 180		
	LP	P	ØD	LP	P	ØD	LP	P	ØD	LP	P	ØD
2501	231			265			304			304	139	350
2502	279	66	250	313	100	300	352	139	350	-		
2503	327			361			-			-		
2504	375			-			-			-		

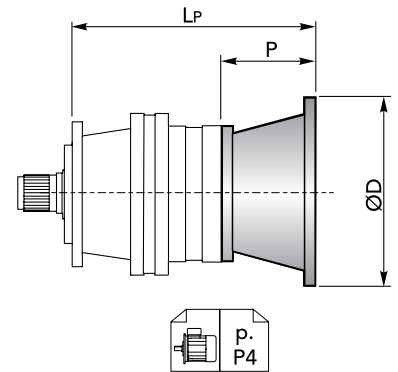

CHPL 2500 CMS - Alberi maschi entrata | Male input shafts

CHPL	CM42				CM65				CP65			
	LT	T	LE	ØE	LT	T	LE	ØE	LT	T	LE	ØE
2501	258				300	121.5	105	65 h6	331.5	153	105	65 h6
2502	306	93	82	42 h6	-				-			
2503	354				-				-			
2504	402				-				-			

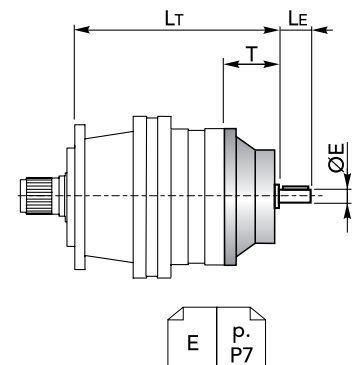



DIMENSIONI · DIMENSIONS

CHPL 2500 CMS - Riduttore a vite senza fine CHM in entrata | *CHM input worm gearboxes*

CHPL	CHM 50					CHM 63				
	Lv	I	H	M	N	Lv	I	H	M	N
2501	290.5	50	110	60	80	300	63	135	72	95
2502	338.5					348				
2503	386.5					396				
2504	434.5					444				

CHPL	CHM 75					CHM 90				
	Lv	I	H	M	N	Lv	I	H	M	N
2501	279	75	161	86	112.5	289	90	193	103	129.5
2502	327					337				
2503	375					385				
2504	423					433				

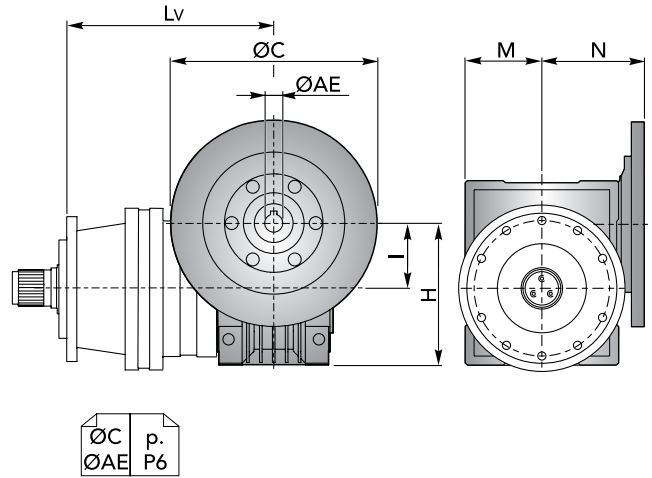

CHPL / CHPLB 2500 CMS

CHPLB 2500 CMS - Flange motori IEC | *IEC Motor flanges*

CHPLB	IEC 63				IEC 71				IEC 80				IEC 90			
	L	LP	P	ØD	L	LP	P	ØD	L	LP	P	ØD	L	LP	P	ØD
2502	240	196	36	140	240	196	36	160	240	216	56	200	240	216	56	200
2503	288				288				336							
2504	336				336				336							

CHPLB	IEC 100				IEC 112				IEC 132				IEC 160			
	L	LP	P	ØD	L	LP	P	ØD	L	LP	P	ØD	L	LP	P	ØD
2502	240	226	66	250	240	226	66	250	240	260	100	300	240	299	139	350
2503	288				288				336							
2504	336				336				336							

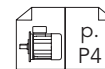
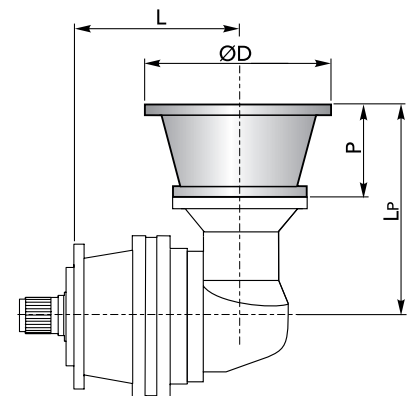

CHPLB 2500 CMS - Alberi maschi entrata | *Male input shafts*

CHPLB	CM42					CM65					CP65				
	L	L _T	T	L _E	ØE	L	L _T	T	L _E	ØE	L	L _T	T	L _E	ØE
2502	240	253	93	82	42 h6	240	297.5	121.5	105	65 h6	240	329	153	105	65 h6
2503	288					288					336				
2504	336					336					336				

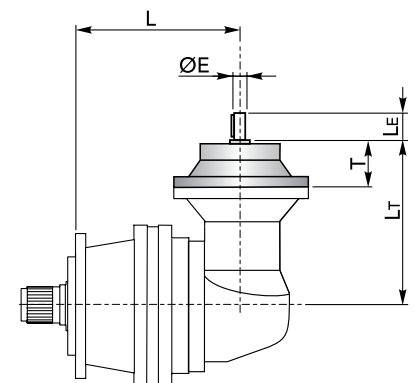

DIMENSIONI · DIMENSIONS

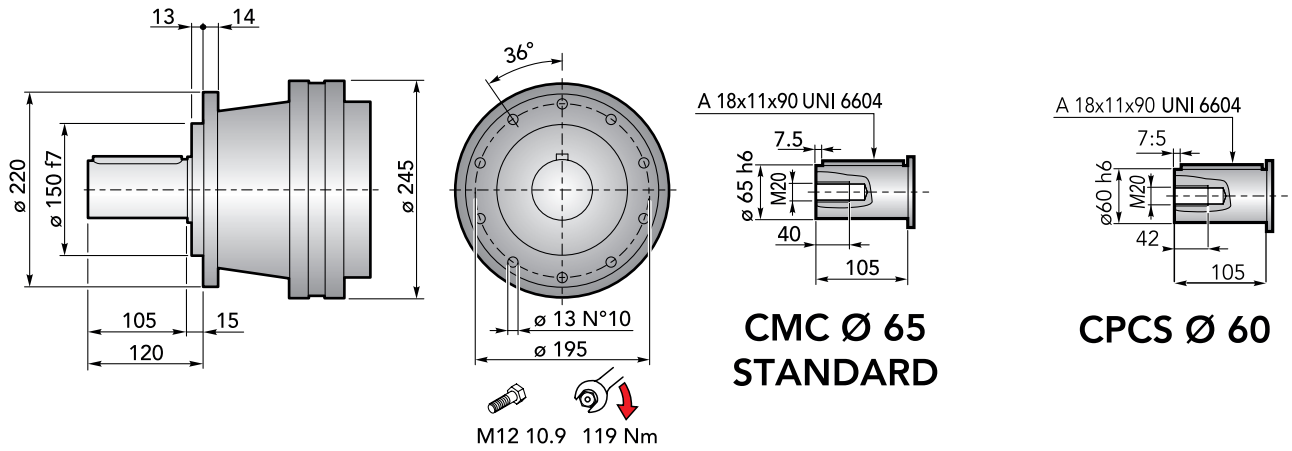

CHPL 2500 CMC - Flange motori IEC | IEC Motor flanges

CHPL	IEC 63			IEC 71			IEC 80			IEC 90			IEC 100		
	LP	P	ØD	LP	P	ØD	LP	P	ØD	LP	P	ØD	LP	P	ØD
2501	201			201			221			221			231		
2502	249	36	140	249	36	160	269	56	200	269	56	200	279	66	250
2503	297			297			317			317			327		
2504	345			345			365			365			375		

CHPL	IEC 112			IEC 132			IEC 160			IEC 180		
	LP	P	ØD	LP	P	ØD	LP	P	ØD	LP	P	ØD
2501	231			265			304			304	139	350
2502	279	66	250	313	100	300	352	139	350	-	-	-
2503	327			361			-	-	-	-	-	-
2504	375			-	-	-	-	-	-	-	-	-

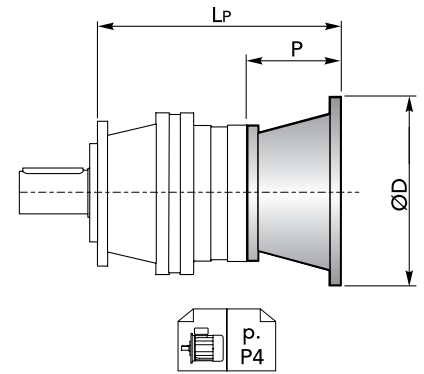

CHPL 2500 CMC - Alberi maschi entrata | Male input shafts

CHPL	CM42				CM65				CP65			
	LT	T	LE	ØE	LT	T	LE	ØE	LT	T	LE	ØE
2501	258				300	121.5	105	65 h6	331.5	153	105	65 h6
2502	306	93	82	42 h6	-	-	-	-	-	-	-	-
2503	354				-	-	-	-	-	-	-	-
2504	402				-	-	-	-	-	-	-	-

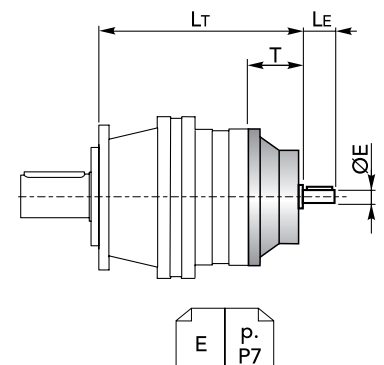



DIMENSIONI · DIMENSIONS

CHPL 2500 CMC - Riduttore a vite senza fine CHM in entrata | *CHM input worm gearboxes*

CHPL	CHM 50					CHM 63				
	Lv	I	H	M	N	Lv	I	H	M	N
2501	290.5	50	110	60	80	300	63	135	72	95
2502	338.5					348				
2503	386.5					396				
2504	434.5					444				

CHPL	CHM 75					CHM 90				
	Lv	I	H	M	N	Lv	I	H	M	N
2501	279	75	161	86	112.5	289	90	193	103	129.5
2502	327					337				
2503	375					385				
2504	423					433				

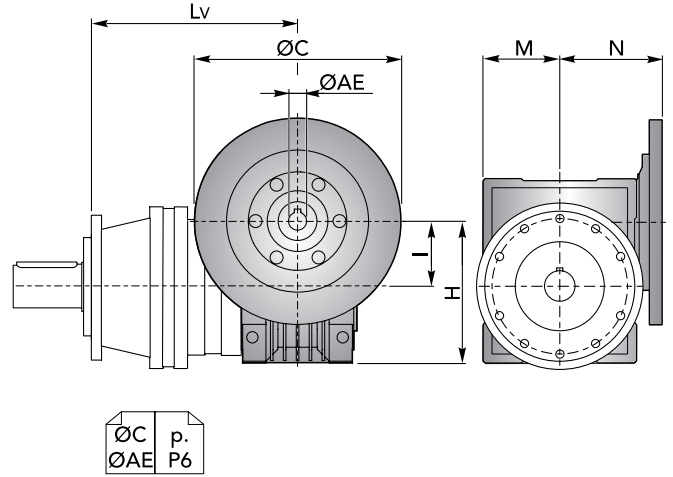

CHPL / CHPLB 2500 CMC

CHPLB 2500 CMC - Flange motori IEC | *IEC Motor flanges*

CHPLB	IEC 63				IEC 71				IEC 80				IEC 90			
	L	LP	P	ØD	L	LP	P	ØD	L	LP	P	ØD	L	LP	P	ØD
2502	240	196	36	140	240	196	36	160	240	216	56	200	240	216	56	200
2503	288				288				336							
2504	336				336				336							

CHPLB	IEC 100				IEC 112				IEC 132				IEC 160			
	L	LP	P	ØD	L	LP	P	ØD	L	LP	P	ØD	L	LP	P	ØD
2502	240	226	66	250	240	226	66	250	240	260	100	300	240	299	139	350
2503	288				288				336				-			
2504	336				336				336				-			

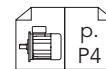
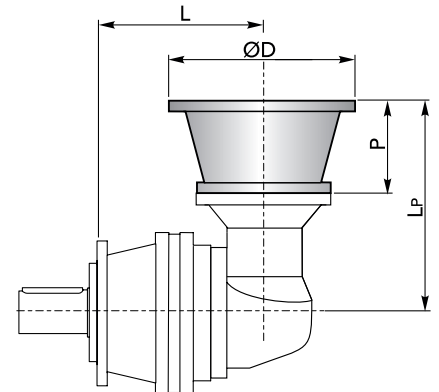

CHPLB 2500 CMC - Alberi maschi entrata | *Male input shafts*

CHPLB	CM42					CM65					CP65				
	L	L _T	T	L _E	ØE	L	L _T	T	L _E	ØE	L	L _T	T	L _E	ØE
2502	240	253	93	82	42 h6	240	297.5	121.5	105	65 h6	240	329	153	105	65 h6
2503	288					288					336				
2504	336					336					336				

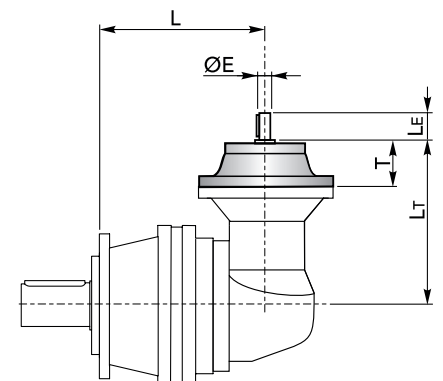

DIMENSIONI · DIMENSIONS

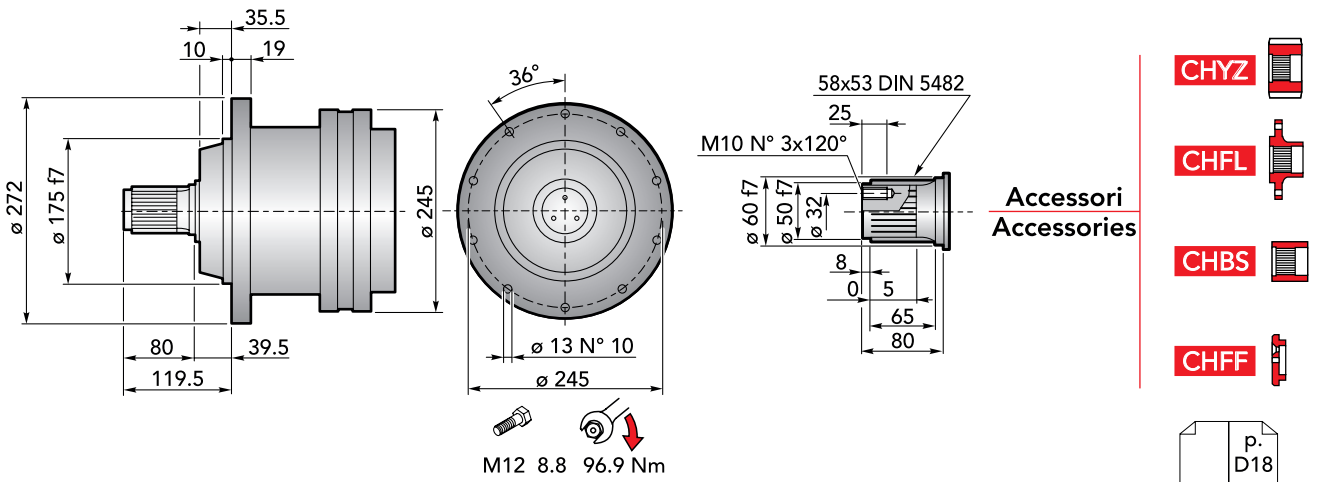

CHPL 2500 CPS - Flange motori IEC | IEC Motor flanges

CHPL	IEC 63			IEC 71			IEC 80			IEC 90			IEC 100		
	LP	P	ØD	LP	P	ØD	LP	P	ØD	LP	P	ØD	LP	P	ØD
2501	208			208			228			228			238		
2502	256	36	140	256	36	160	276	56	200	276	56	200	286	66	250
2503	304			304			324			324			334		
2504	352			352			372			372			382		

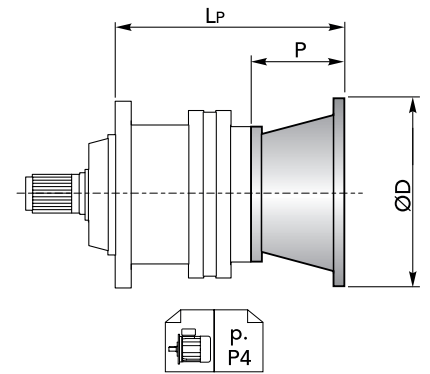

CHPL	IEC 112			IEC 132			IEC 160			IEC 180		
	LP	P	ØD	LP	P	ØD	LP	P	ØD	LP	P	ØD
2501	238			272			311			311	139	350
2502	286	66	250	320	100	300	359	139	350			
2503	334			368								
2504	382											

CHPL 2500 CPS - Alberi maschi entrata | Male input shafts

CHPL	CM42				CM65				CP65				
	LT	T	LE	ØE	LT	T	LE	ØE	LT	T	LE	ØE	
2501	265				307	121.5	105	65 h6	338.5	153	105	65 h6	
2502	313	93	82	42 h6									
2503	361												
2504	409												

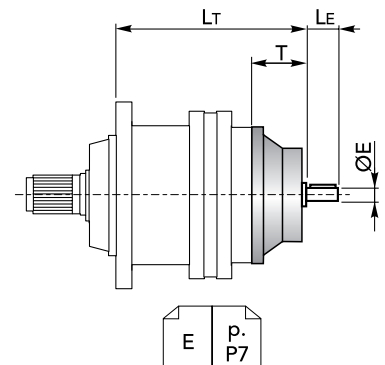



DIMENSIONI · DIMENSIONS

CHPL 2500 CPS - Riduttore a vite senza fine CHM in entrata | *CHM input worm gearboxes*

CHPL	CHM 50					CHM 63				
	Lv	I	H	M	N	Lv	I	H	M	N
2501	297.5	50	110	60	80	307	63	135	72	95
2502	345.5					355				
2503	393.5					403				
2504	441.5					451				

CHPL	CHM 75					CHM 90				
	Lv	I	H	M	N	Lv	I	H	M	N
2501	286	75	161	86	112.5	296	90	193	103	129.5
2502	334					344				
2503	382					392				
2504	430					440				

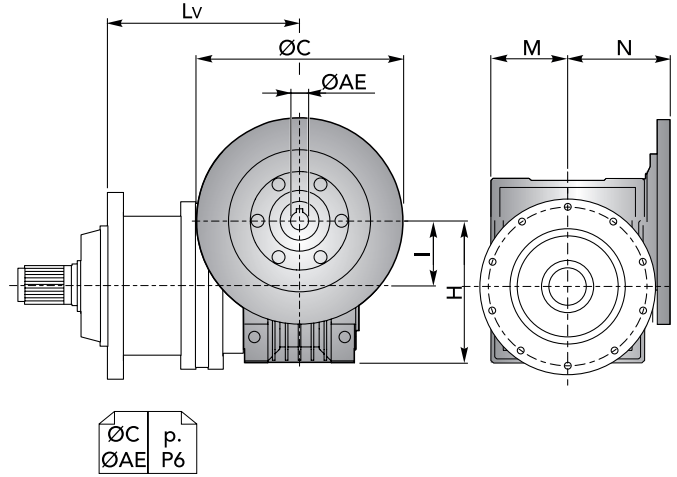

CHPL / CHPLB 2500 CPS

CHPLB 2500 CPS - Flange motori IEC | *IEC Motor flanges*

CHPLB	IEC 63				IEC 71				IEC 80				IEC 90			
	L	Lp	P	ØD	L	Lp	P	ØD	L	Lp	P	ØD	L	Lp	P	ØD
2502	247	196	36	140	247	196	36	160	247	216	56	200	247	216	56	200
2503	295				295				295							
2504	343				343				343							

CHPLB	IEC 100				IEC 112				IEC 132				IEC 160			
	L	Lp	P	ØD	L	Lp	P	ØD	L	Lp	P	ØD	L	Lp	P	ØD
2502	247	226	66	250	247	226	66	250	247	260	100	300	247	299	139	350
2503	295				295				295							
2504	343				343				343							

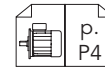
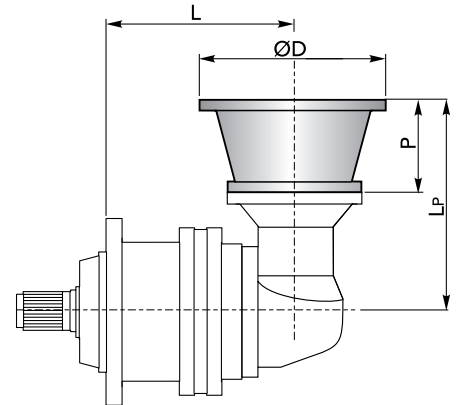

CHPLB 2500 CPS - Alberi maschi entrata | *Male input shafts*

CHPLB	CM42					CM65					CP65				
	L	Lt	T	Le	ØE	L	Lt	T	Le	ØE	L	Lt	T	Le	ØE
2502	247	253	93	82	42 h6	247	297.5	121.5	105	65 h6	247	329	153	105	65 h6
2503	295					295					295				
2504	343					343					343				

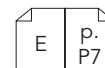
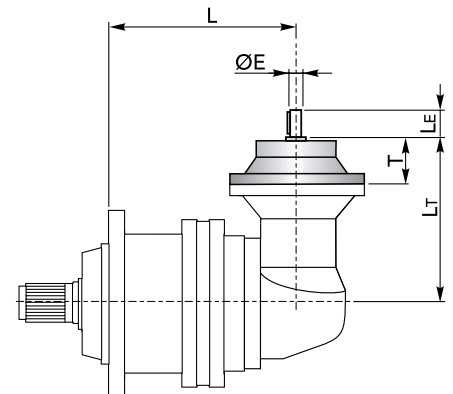

DIMENSIONI · DIMENSIONS

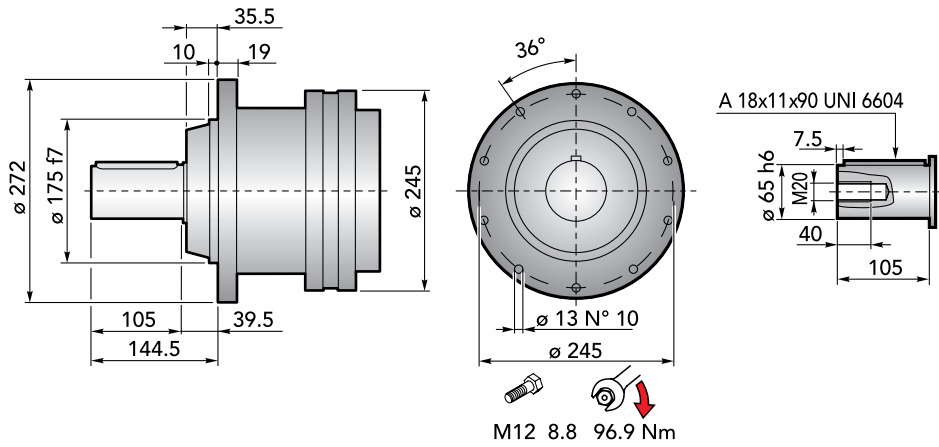

CHPL 2500 CPC - Flange motori IEC | IEC Motor flanges

CHPL	IEC 63			IEC 71			IEC 80			IEC 90			IEC 100		
	LP	P	ØD	LP	P	ØD	LP	P	ØD	LP	P	ØD	LP	P	ØD
2501	208			208			228			228			238		
2502	256	36	140	256	36	160	276	56	200	276	56	200	286	66	250
2503	304			304			324			324			334		
2504	352			352			372			372			382		

CHPL	IEC 112			IEC 132			IEC 160			IEC 180		
	LP	P	ØD	LP	P	ØD	LP	P	ØD	LP	P	ØD
2501	238			272			311			311	139	350
2502	286	66	250	320	100	300	359	139	350			
2503	334			368								
2504	382											

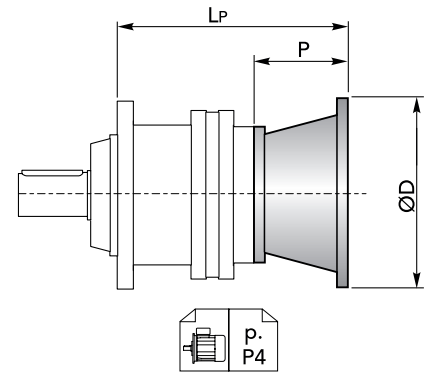

CHPL 2500 CPC - Alberi maschi entrata | Male input shafts

CHPL	CM42				CM65				CP65				
	LT	T	LE	ØE	LT	T	LE	ØE	LT	T	LE	ØE	
2501	265				307	121.5	105	65 h6	338.5	153	105	65 h6	
2502	313	93	82	42 h6									
2503	361												
2504	409												

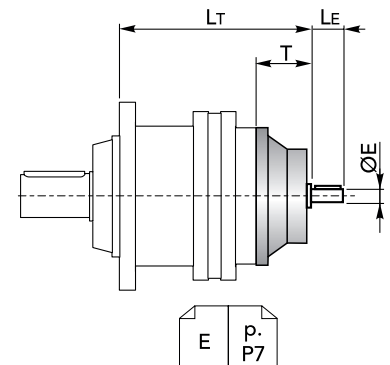



DIMENSIONI · DIMENSIONS

CHPL 2500 CPC - Riduttore a vite senza fine CHM in entrata | *CHM input worm gearboxes*

CHPL	CHM 50					CHM 63				
	Lv	I	H	M	N	Lv	I	H	M	N
2501	297.5	50	110	60	80	307	63	135	72	95
2502	345.5					355				
2503	393.5					403				
2504	441.5					451				

CHPL	CHM 75					CHM 90				
	Lv	I	H	M	N	Lv	I	H	M	N
2501	286	75	161	86	112.5	296	90	193	103	129.5
2502	334					344				
2503	382					392				
2504	430					440				

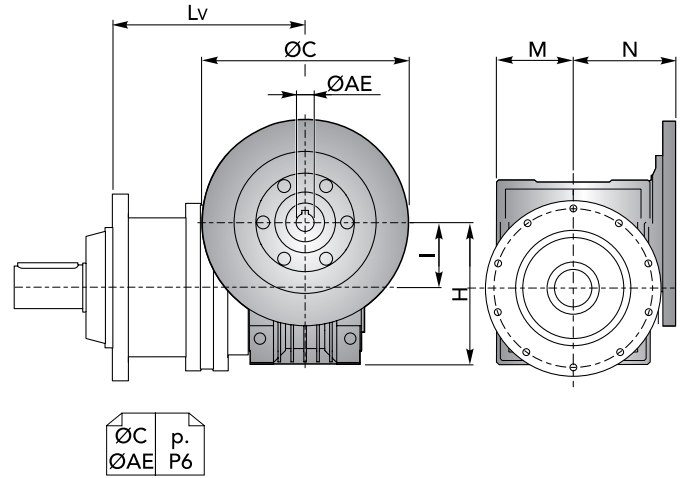

CHPLB 2500 CPC - Flange motori IEC | *IEC Motor flanges*

CHPLB	IEC 63				IEC 71				IEC 80				IEC 90			
	L	Lp	P	ØD	L	Lp	P	ØD	L	Lp	P	ØD	L	Lp	P	ØD
2502	247	196	36	140	247	196	36	160	247	216	56	200	247	216	56	200
2503	295				295				295							
2504	343				343				343							

CHPLB	IEC 100				IEC 112				IEC 132				IEC 160			
	L	Lp	P	ØD	L	Lp	P	ØD	L	Lp	P	ØD	L	Lp	P	ØD
2502	247	226	66	250	247	226	66	250	247	260	100	300	247	299	139	350
2503	295				295				295							
2504	343				343				343							

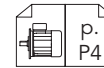
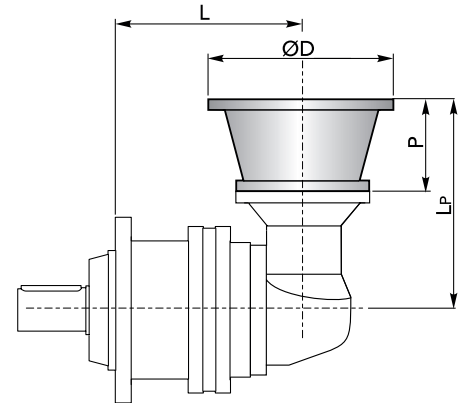

CHPLB 2500 CPC - Alberi maschi entrata | *Male input shafts*

CHPLB	CM42					CM65					CP65				
	L	Lt	T	Le	ØE	L	Lt	T	Le	ØE	L	Lt	T	Le	ØE
2502	247	253	93	82	42 h6	247	297.5	121.5	105	65 h6	247	329	153	105	65 h6
2503	295					295					295				
2504	343					343					343				

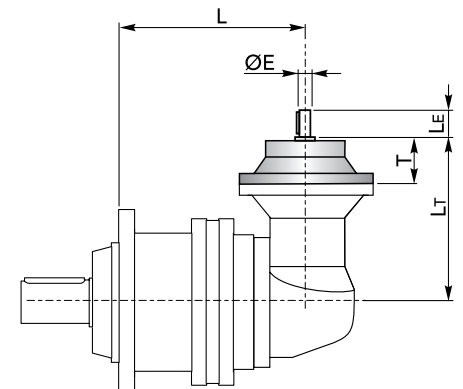

DIMENSIONI · DIMENSIONS

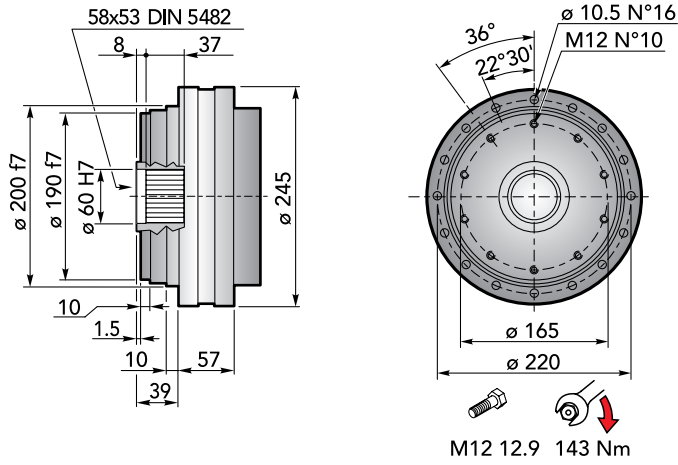

Accessori
Accessories

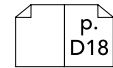

CHPL 2500 CF - Flange motori IEC | IEC Motor flanges

CHPL	IEC 63			IEC 71			IEC 80			IEC 90			IEC 100		
	L _P	P	ØD	L _P	P	ØD	L _P	P	ØD	L _P	P	ØD	L _P	P	ØD
2501	114.5	36	140	114.5	36	160	134.5	56	200	134.5	56	200	144.5	66	250
2502	162.5			162.5			182.5			182.5			192.5		
2503	210.5			210.5			230.5			230.5			240.5		
2504	258.5			258.5			278.5			278.5			288.5		

CHPL	IEC 112			IEC 132			IEC 160			IEC 180		
	L _P	P	ØD	L _P	P	ØD	L _P	P	ØD	L _P	P	ØD
2501	144.5	66	250	178.5	100	300	217.5	139	350	217.5	139	350
2502	192.5			226.5			-			-		
2503	240.5			274.5			-			-		
2504	288.5			-			-			-		

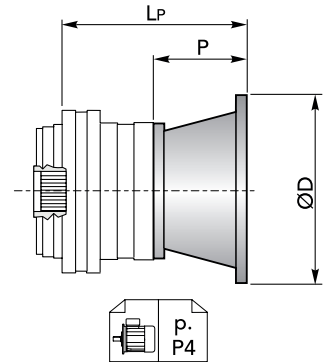

CHPL 2500 CF - Alberi maschi entrata | Male input shafts

CHPL	CM42				CM65				CP65			
	L _T	T	L _E	ØE	L _T	T	L _E	ØE	L _T	T	L _E	ØE
2501	171.5	93	82	42 h6	213.5	121.5	105	65 h6	245	153	105	65 h6
2502	219.5				-	-	-	-	-	-		
2503	267.5				-	-	-	-	-	-		
2504	315.5				-	-	-	-	-	-		

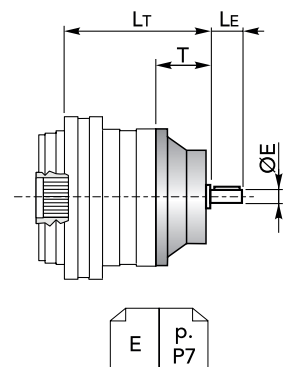



DIMENSIONI · DIMENSIONS

CHPL 2500 CF - Riduttore a vite senza fine CHM in entrata | *CHM input worm gearboxes*

CHPL	CHM 50					CHM 63				
	Lv	I	H	M	N	Lv	I	H	M	N
2501	204	50	110	60	80	213.5	63	135	72	95
2502	252					261.5				
2503	300					309.5				
2504	348					357.5				

CHPL	CHM 75					CHM 90				
	Lv	I	H	M	N	Lv	I	H	M	N
2501	192.5	75	161	86	112.5	202.5	90	193	103	129.5
2502	240.5					250.5				
2503	288.5					298.5				
2504	336.5					346.5				

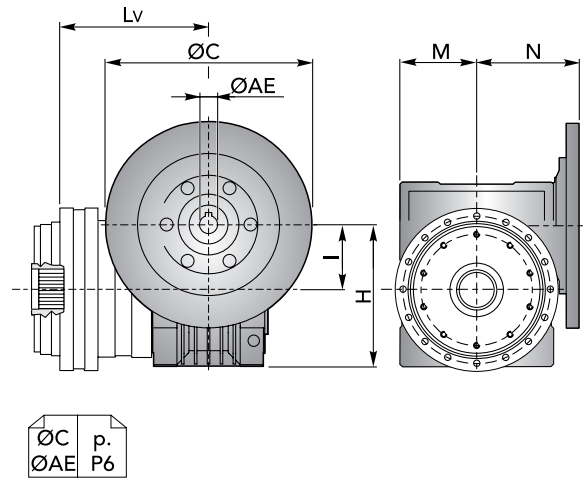

CHPL / CHPLB 2500 CF

CHPLB 2500 CF - Flange motori IEC | *IEC Motor flanges*

CHPLB	IEC 63				IEC 71				IEC 80				IEC 90			
	L	Lp	P	ØD	L	Lp	P	ØD	L	Lp	P	ØD	L	Lp	P	ØD
2502	191	196	36	140	191	196	36	160	191	216	56	200	191	216	56	200
2503	239				239				239							
2504	287				287				287							

CHPLB	IEC 100				IEC 112				IEC 132				IEC 160			
	L	Lp	P	ØD	L	Lp	P	ØD	L	Lp	P	ØD	L	Lp	P	ØD
2502	191	226	66	250	191	226	66	250	191	260	100	300	191	299	139	350
2503	239				239				-							
2504	287				287				-							

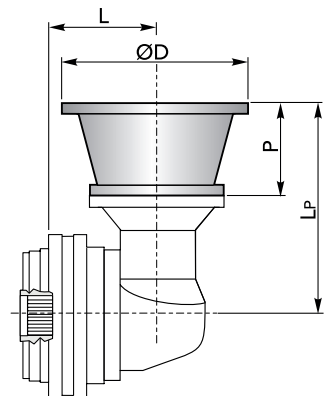

CHPLB 2500 CF - Alberi maschi entrata | *Male input shafts*

CHPLB	CM42					CM65					CP65				
	L	Lt	T	Le	ØE	L	Lt	T	Le	ØE	L	Lt	T	Le	ØE
2502	191	253	93	82	42 h6	191	297.5	121.5	105	65 h6	191	329	153	105	65 h6
2503	239					239					239				
2504	287					287					287				

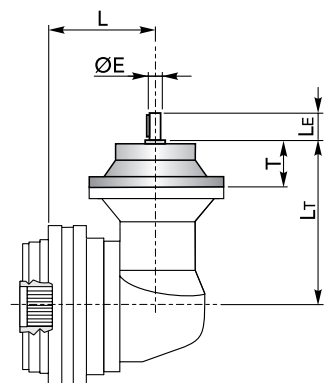

DIMENSIONI · DIMENSIONS

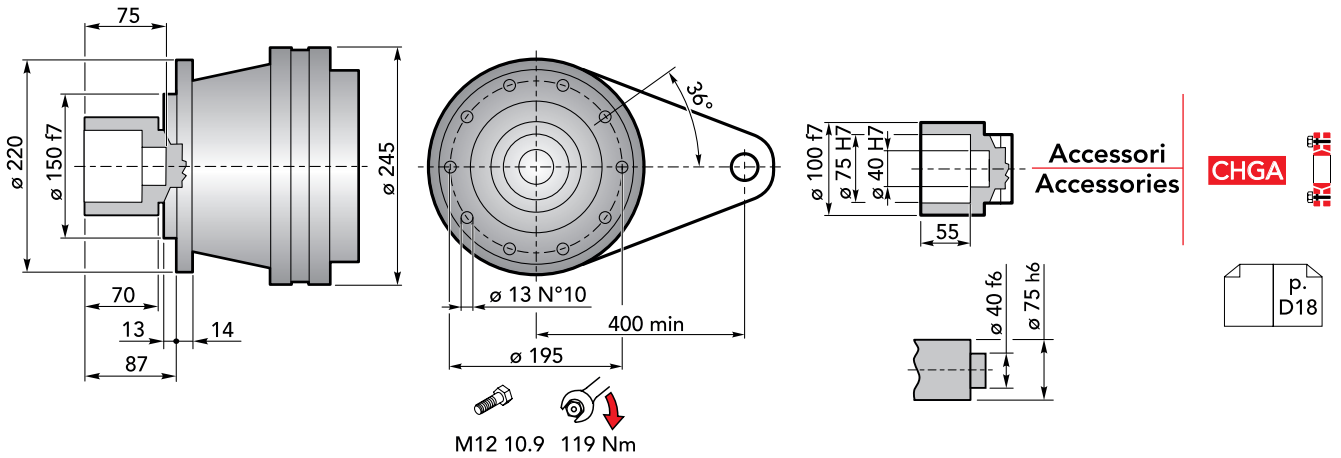

CHPL 2500 CFS - Flange motori IEC | IEC Motor flanges

CHPL	IEC 63			IEC 71			IEC 80			IEC 90			IEC 100		
	LP	P	ØD	LP	P	ØD	LP	P	ØD	LP	P	ØD	LP	P	ØD
2501	201			201			221			221			231		
2502	249	36	140	249	36	160	269	56	200	269	56	200	279	66	250
2503	297			297			317			317			327		
2504	345			345			365			365			375		

CHPL	IEC 112			IEC 132			IEC 160			IEC 180		
	LP	P	ØD	LP	P	ØD	LP	P	ØD	LP	P	ØD
2501	231	66	250	265	100	300	304	139	350	304	139	350
2502	279			313			-			-		
2503	327			361			-			-		
2504	375			-			-			-		

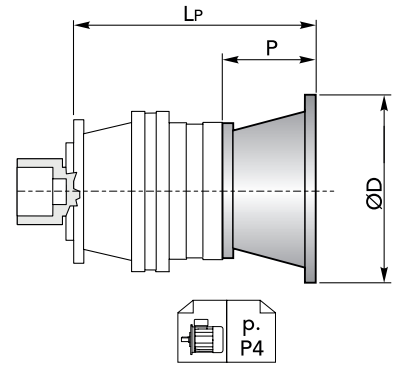

CHPL 2500 CFS - Alberi maschi entrata | Male input shafts

CHPL	CM42				CM65				CP65			
	LT	T	LE	ØE	LT	T	LE	ØE	LT	T	LE	ØE
2501	258	93	82	42 h6	300	121.5	105	65 h6	331.5	153	105	65 h6
2502	306				-	-	-					
2503	354				-	-	-					
2504	402				-	-	-					

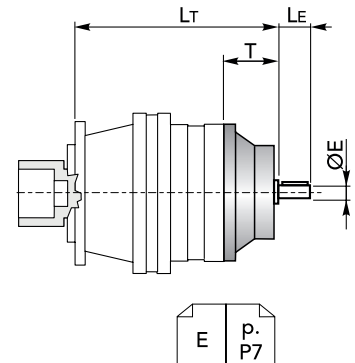



DIMENSIONI · DIMENSIONS

CHPL 2500 CFS - Riduttore a vite senza fine CHM in entrata | *CHM input worm gearboxes*

CHPL	CHM 50					CHM 63				
	Lv	I	H	M	N	Lv	I	H	M	N
2501	290.5	50	110	60	80	300	63	135	72	95
2502	338.5					348				
2503	386.5					396				
2504	434.5					444				

CHPL	CHM 75					CHM 90				
	Lv	I	H	M	N	Lv	I	H	M	N
2501	279	75	161	86	112.5	289	90	193	103	129.5
2502	327					337				
2503	375					385				
2504	423					433				

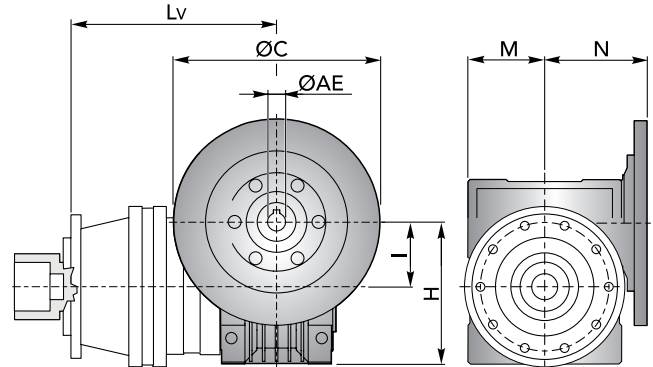

CHPL / CHPLB 2500 CFS

CHPLB 2500 CFS - Flange motori IEC | *IEC Motor flanges*

CHPLB	IEC 63				IEC 71				IEC 80				IEC 90			
	L	LP	P	ØD	L	LP	P	ØD	L	LP	P	ØD	L	LP	P	ØD
2502	240	196	36	140	240	196	36	160	240	216	56	200	240	216	56	200
2503	288				288				336							
2504	336				336				336							

CHPLB	IEC 100				IEC 112				IEC 132				IEC 160			
	L	LP	P	ØD	L	LP	P	ØD	L	LP	P	ØD	L	LP	P	ØD
2502	240	226	66	250	240	226	66	250	240	260	100	300	240	299	139	350
2503	288				288				336				-			
2504	336				336				336				-			

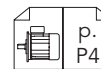
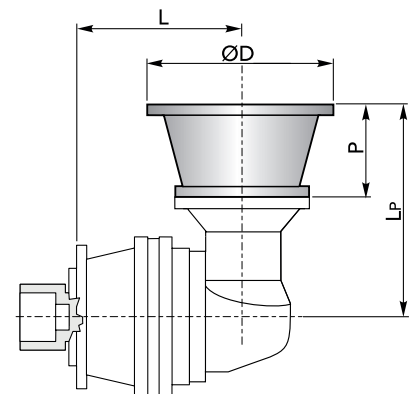

CHPLB 2500 CFS - Alberi maschi entrata | *Male input shafts*

CHPLB	CM42					CM65					CP65				
	L	L _T	T	L _E	ØE	L	L _T	T	L _E	ØE	L	L _T	T	L _E	ØE
2502	240	253	93	82	42 h6	240	297.5	121.5	105	65 h6	240	329	153	105	65 h6
2503	288					288					336				
2504	336					336					336				

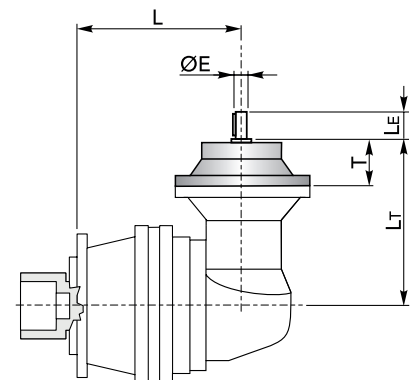

DIMENSIONI · DIMENSIONS

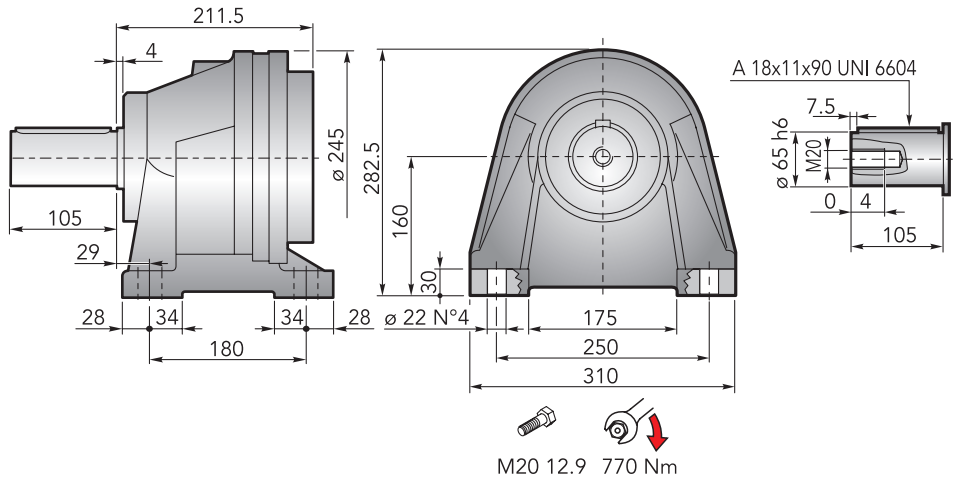

CHPL 2500 CCPC - Flange motori IEC | IEC Motor flanges

CHPL	IEC 63			IEC 71			IEC 80			IEC 90			IEC 100		
	Lp	P	ØD	Lp	P	ØD	Lp	P	ØD	Lp	P	ØD	Lp	P	ØD
2501	247.5	36	140	247.5	36	160	267.5	56	200	267.5	56	200	277.5	66	250
2502	295.5			315.5			315.5			325.5					
2503	343.5			343.5			363.5			373.5					
2504	391.5			391.5			411.5			421.5					

CHPL	IEC 112			IEC 132			IEC 160			IEC 180		
	Lp	P	ØD	Lp	P	ØD	Lp	P	ØD	Lp	P	ØD
2501	277.5	66	250	311.5	100	300	350.5	139	350	350.5	139	350
2502	325.5			359.5			-			-		
2503	373.5			407.5			-			-		
2504	421.5			-			-			-		

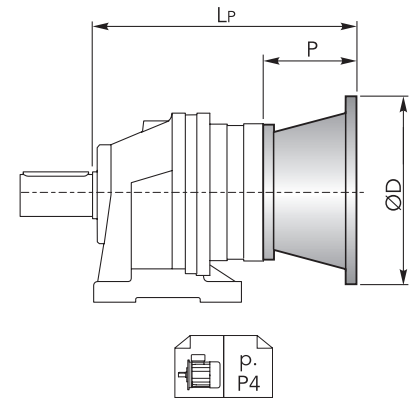

CHPL 2500 CCPC - Alberi maschi entrata | Male input shafts

CHPL	CM42				CM65				CP65			
	Lt	T	Le	ØE	Lt	T	Le	ØE	Lt	T	Le	ØE
2501	304.5	93	82	42 h6	346.5	121.5	105	65 h6	378	153	105	65 h6
2502	352.5				-	-	-					
2503	400.5				-	-	-					
2504	448.5				-	-	-					

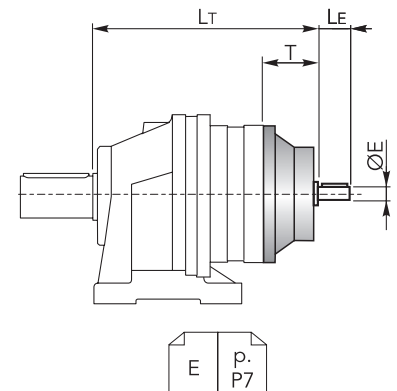



DIMENSIONI · DIMENSIONS

CHPL 2500 CCPC - Riduttore a vite senza fine CHM in entrata | *CHM input worm gearboxes*

CHPL	CHM 50					CHM 63				
	Lv	I	H	M	N	Lv	I	H	M	N
2501	337	50	110	60	80	346.5	63	135	72	95
2502	385					394.5				
2503	433					442.5				
2504	481					490.5				

CHPL	CHM 75					CHM 90				
	Lv	I	H	M	N	Lv	I	H	M	N
2501	325.5	75	161	86	112.5	335.5	90	193	103	129.5
2502	373.5					383.5				
2503	421.5					431.5				
2504	469.5					479.5				

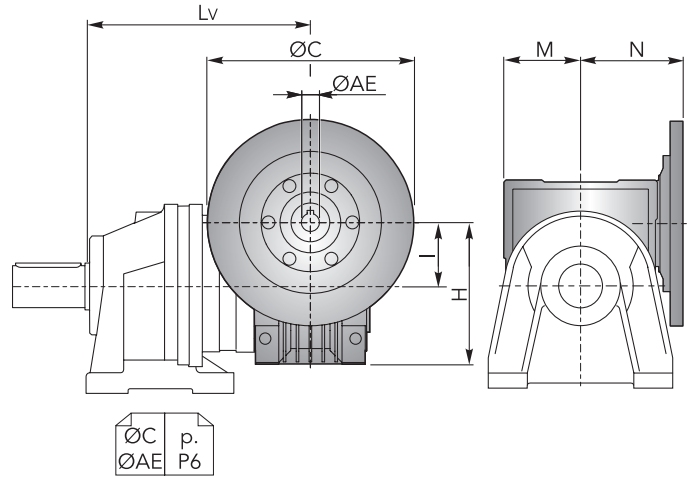

CHPL / CHPLB 2500 CCPC

CHPLB 2500 CCPC - Flange motori IEC | *IEC Motor flanges*

CHPLB	IEC 63				IEC 71				IEC 80				IEC 90			
	L	Lp	P	ØD	L	Lp	P	ØD	L	Lp	P	ØD	L	Lp	P	ØD
2502	286.5	196	36	140	286.5	196	36	160	286.5	216	56	200	286.5	216	56	200
2503	334.5				334.5				334.5							
2504	382.5				382.5				382.5							

CHPLB	IEC 100				IEC 112				IEC 132				IEC 160			
	L	Lp	P	ØD	L	Lp	P	ØD	L	Lp	P	ØD	L	Lp	P	ØD
2502	286.5	226	66	250	286.5	226	66	250	286.5	260	100	300	286.5	299	139	350
2503	334.5				334.5				-							
2504	382.5				382.5				-							

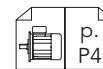
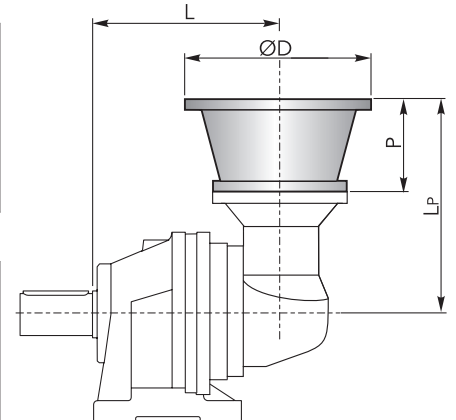

CHPLB 2500 CCPC - Alberi maschi entrata | *Male input shafts*

CHPLB	CM42					CM65					CP65				
	L	Lt	T	Le	ØE	L	Lt	T	Le	ØE	L	Lt	T	Le	ØE
2502	286.5	253	93	82	42 h6	286.5	297.5	121.5	105	65 h6	286.5	329	153	105	65 h6
2503	334.5					334.5					334.5				
2504	382.5					382.5					382.5				

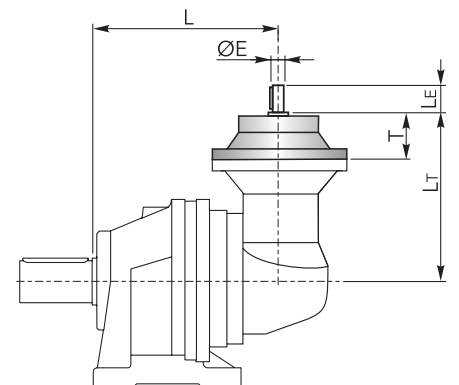

ACCESSORI · ACCESSORIES

CHYZ



Pignoni | Pinions

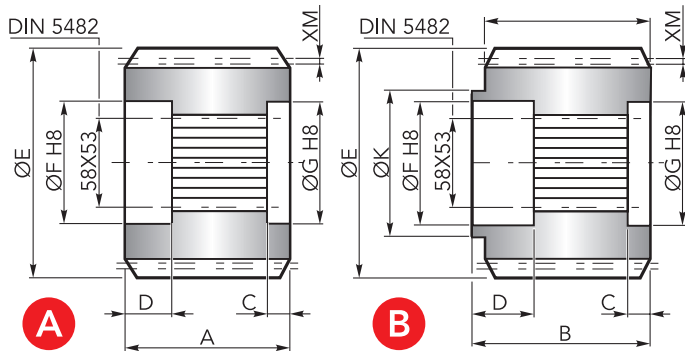

	Uscita / Output	Dimensions										Codice / Code	
		M	Z	XM	A	B	C	D	E	F	G		K
A	CMS	8	13	0	68	-	8.5	22.5	120	60	60	-	1071.218.042
	CMS	8	11	5	68	-	8.5	22.5	110.8	60	60	-	1071.258.042
	CMS	8	12	0	68	-	8	21	112.8	60	60	-	1071.196.042
	CMS	8	15	0	68	-	8.5	22.5	136	60	60	-	1071.163.042
	CPS	6	14	3	95	.	23	21	99.6	60	60	-	1071.160.042
	CPS	10	11	8	90	-	8.5	22.5	142.1	60	60	-	1071.297.042
B	CPS	10	14	3.2	103	116	9.5	22.5	162.4	60	60	105	1071.298.042

CHFF



Fondello di arresto | Stop bottom plate

Codice / Code:
1075.015.000

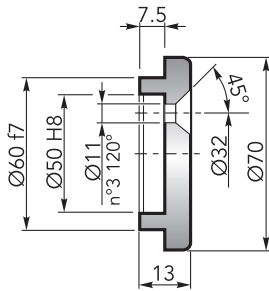

CHBS



Boccola scanalata | Splined bushing

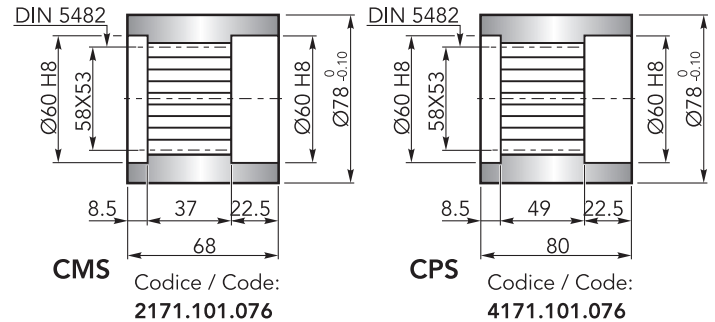

CHKB



Barra scanalata | Splined rod

Codice / Code:
3071.181.042

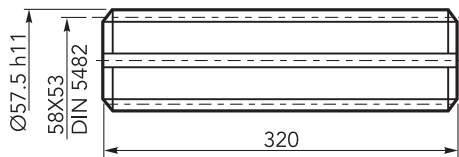

CHGA



Giunto di attrito | Shrink disc

Codice / Code:
5109.100.000

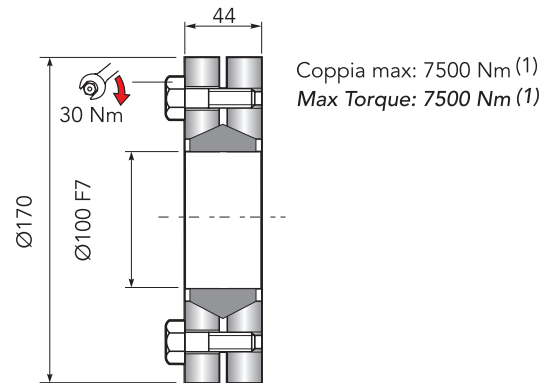

Coppia max: 7500 Nm (1)
Max Torque: 7500 Nm (1)

(1): Coppia max indicata è valida solo con calettatori forniti da Chiaravalli S.p.A.

(1): The maximum torque indicated is valid only with shrink discs supplied by Chiaravalli S.p.A.

CHFL



Flangia | Flange

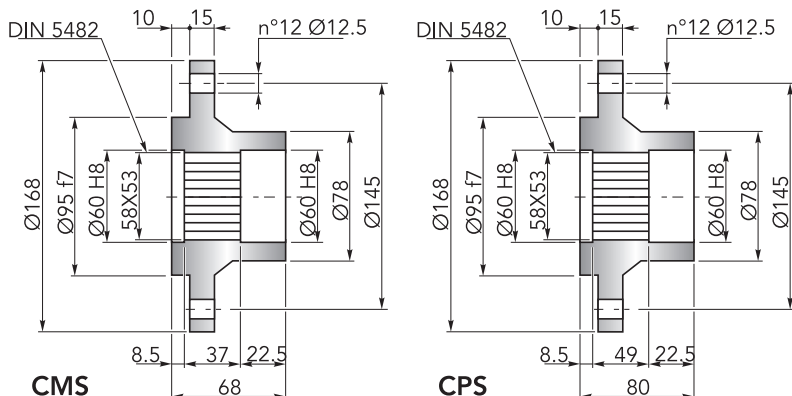

CMS

Codice / Code:
2171.103.025

CPS

Codice / Code:
4171.103.098



CARICHI RADIALI (Fr) · RADIAL LOADS (Fr)

Nel diagramma seguente, sono indicati i carichi radiali F_r (N) applicabili sull'albero uscita in funzione della distanza di applicazione L rispetto alla battuta dell'albero.

The hereunder table shows the allowable radial loads F_r (N) on the output shaft with reference to the distance L .

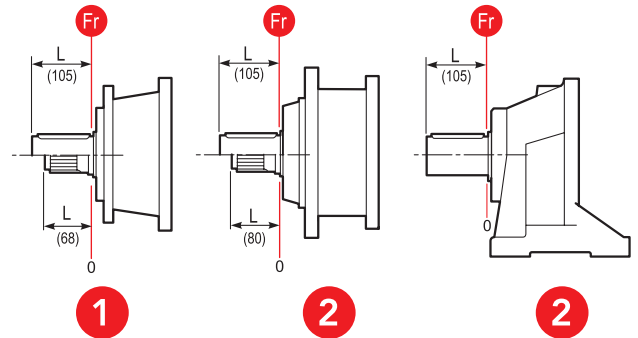
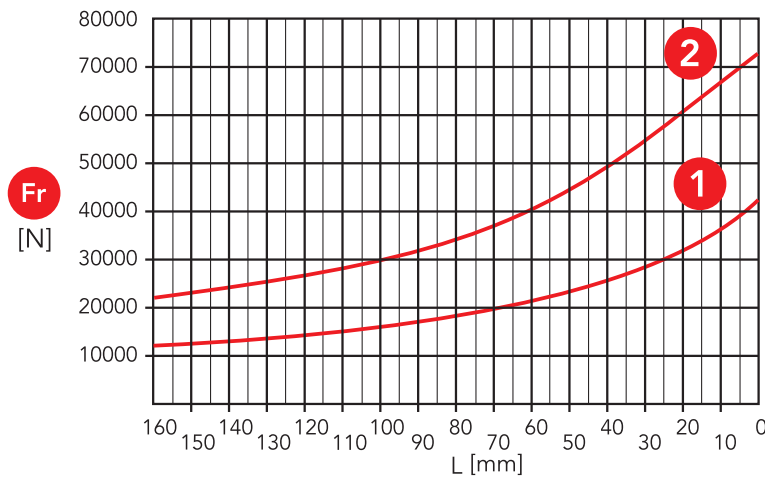

- 1** Uscita / Output: CMS, CMC
- 2** Uscita / Output: CPS, CPC, CCPC

CARICHI ASSIALI (Fa) · AXIAL LOADS (Fa)

Nella tabella seguente sono indicati i carichi assiali F_a (N) applicabili sull'albero di uscita in funzione della direzione di applicazione del carico e della versione.

The hereunder table shows the allowable axial loads F_a (N) on the output shaft with reference to the load direction and the output type.

	1	2	
Fa [N]	32000	32000	←
	32000	48000	→

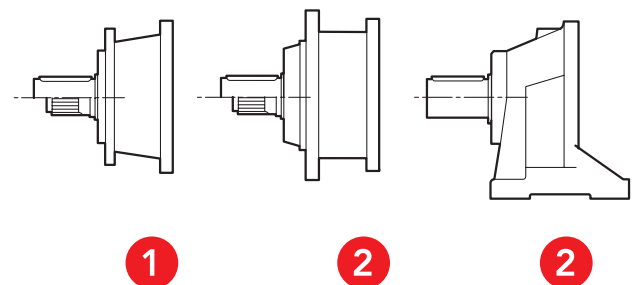

- 1** Uscita / Output: CMS, CMC
- 2** Uscita / Output: CPS, CPC, CCPC





CHPL

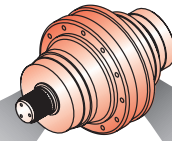

OUT

IN

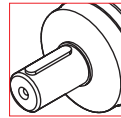

Ø65
Ø60

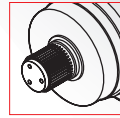

58x53
DIN 5482

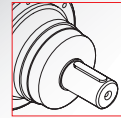

Ø42
Ø65

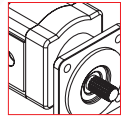

Hydraulic
Motor

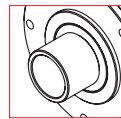

Ø75

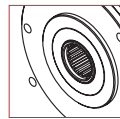

58x53
DIN 5482

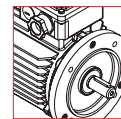

Electric
Motor

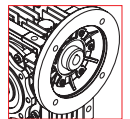

Worm
gearboxes

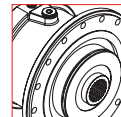

Brake

5001	i 3.78 ÷ 7.25	1 reduction stage
5002	13.4 ÷ 48.9	2 reduction stages
5003	52.1 ÷ 330.3	3 reduction stages
5004	352.0 ÷ 1845.3	4 reduction stages

CHPLB

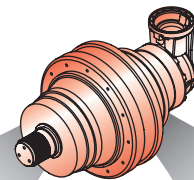

OUT

IN

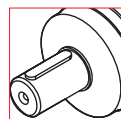

Ø65
Ø60

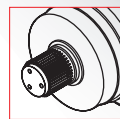

58x53
DIN 5482

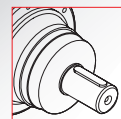

Ø42
Ø65

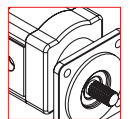

Hydraulic
Motor

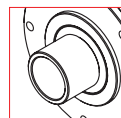

Ø75

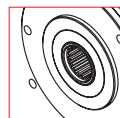

58x53
DIN 5482

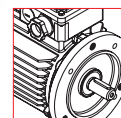

Electric
Motor

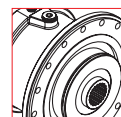

Brake

5002	i 13.1 ÷ 39.5	2 reduction stages
5003	39.4 ÷ 143.5	3 reduction stages
5004	140.1 ÷ 1244.1	4 reduction stages

DATI TECNICI · TECHNICAL DATA

CHPL	i	T _{2n} (n ₁ = 1400 rpm) 10.000h FS=1 [Nm]	P _{1n} (n ₁ = 1400 rpm) 10.000h FS=1 [kW]	T ₂ Max [Nm]	P _t 1400 rpm [kW]	IEC (B5)		CHM		CM/CP
5001	3.78	2164	87	10420	20	63	71	CHM 50 CHM 75	CHM 63 CHM90	CM42 CM 65 CP 65
	4.13	1959	72	9500						
	5.17	1701	50	7780						
	6	1540	39	6820						
	7.25	1230	25.5	5320						
5002	13.4	2810	33	10420	15	63 80 100 132	71 90 112 160	CHM 50 CHM 75	CHM 63 CHM90	CM42
	16.2	2779	27	10420						
	18.4	2105	18	7780						
	23.1	2643	18	9500						
	28.9	2323	12.6	7780						
	34.9	2395	10.8	7780						
	40.5	2162	8.4	6820						
48.9	1708	5.5	5320							
5003	52.1	3232	10.12	9500	10	63 80 100 132	71 90 112 160	CHM 50 CHM 75	CHM 63 CHM90	CM42
	57.6	3573	10.12	10420						
	62.9	3193	8.28	9500						
	75.2	3817	8.28	10420						
	82.1	3321	6.6	9500						
	90.7	3670	6.6	10420						
	99	3471	5.72	9500						
	119.3	3540	4.84	9500						
	129.4	3665	4.62	9500						
	149.5	3024	3.3	7780						
	155.9	3727	3.9	9500						
	162	3058	3.08	7780						
	173.6	2694	2.53	6820						
	195.3	3161	2.64	7780						
	235.4	3246	2.25	7780						
273.4	2891	1.73	6820							
302.2	3473	1.88	7780							
330.3	2431	1.2	5320							
5004	352	4218	2.02	9500	6	63 80 100 132	71 90 112	CHM 50 CHM 75	CHM 63 CHM90	CM42
	365.8	3451	1.44	7780						
	388.6	4655	2.02	10420						
	413.9	4774	1.95	10420						
	424.3	4329	1.73	9500						
	468.4	4987	1.8	10420						
	511.4	4659	1.39	9500						
	554.4	4691	1.29	9500						
	612	5177	1.29	10420						
	668.2	4783	1.09	9500						
	737.7	5280	1.09	10420						
	805.5	4980	0.94	9500						
	858	5024	0.89	9500						
	907.3	4133	0.69	7780						
	1052.5	5136	0.74	9500						
	1121.1	5106	0.7	9500						
	1318.3	4289	0.55	7780						
	1589	4653	0.5	7780						
1845.3	4484	0.38	6820							



n_{1max} = 2800 rpm

per ulteriori rapporti consultare l'ufficio tecnico

for information consult the technical office

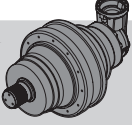

DATI TECNICI · TECHNICAL DATA

 CHPLB	i	T _{2n} (n ₁ = 1400 rpm) 10.000h FS=1 [Nm]	P _{1n} (n ₁ = 1400 rpm) 10.000h FS=1 [kW]	T ₂ Max [Nm]	P _t 1400 rpm [kW]	IEC (B5)	 CM/CP
5002	13.1	2621	31.5	10420	15	63 71 80 90 100 112 132 160	CM42 CM 65 CP 65
	14.2	2436	27	9500			
	17.8	2120	18.75	7780			
	20.6	2845	21.75	10420			
	22.5	2680	18.75	9500			
	28.1	2259	12.65	7780			
	32.7	2078	10	6820			
	39.5	1657	6.6	5320			
5003	39.4	3320	13.75	10420	10	63 71 80 90 100 112 132	CM42 CM 65 CP 65
	47.5	3379	11.6	10420			
	53.9	2577	7.8	7780			
	67.8	3243	7.8	9500			
	75.4	2339	5.06	6820			
	84.9	2748	5.28	7780			
	91.1	1965	3.52	5320			
	102.3	2898	4.62	7780			
	118.8	2564	3.52	6820			
143.5	2129	2.42	5320				
5004	140.1	4011	4.84	10420	6	63 71 80 90 100 112 132	CM42 CM 65 CP 65
	168.9	4198	4.2	10420			
	184.4	3927	3.6	9500			
	220.6	4305	3.3	10420			
	240.9	4077	2.86	9500			
	265.9	4498	2.86	10420			
	290.4	4158	2.42	9500			
	320.6	4589	2.42	10420			
	350	4349	2.1	9500			
	422.4	3160	1.27	6820			
	449.4	4586	1.73	9500			
	475.3	3797	1.35	7780			
	509.1	3342	1.11	6820			
	551.9	3383	1.04	6820			
	615.2	2692	0.74	5320			
	665.3	3494	0.89	6820			
	735.5	4025	0.93	7780			
	801.9	3510	0.74	6820			
	1244.1	2996	0.41	5320			

n_{1max} = 2800 rpm

per ulteriori rapporti consultare l'ufficio tecnico

for information consult the technical office

DIMENSIONI · DIMENSIONS

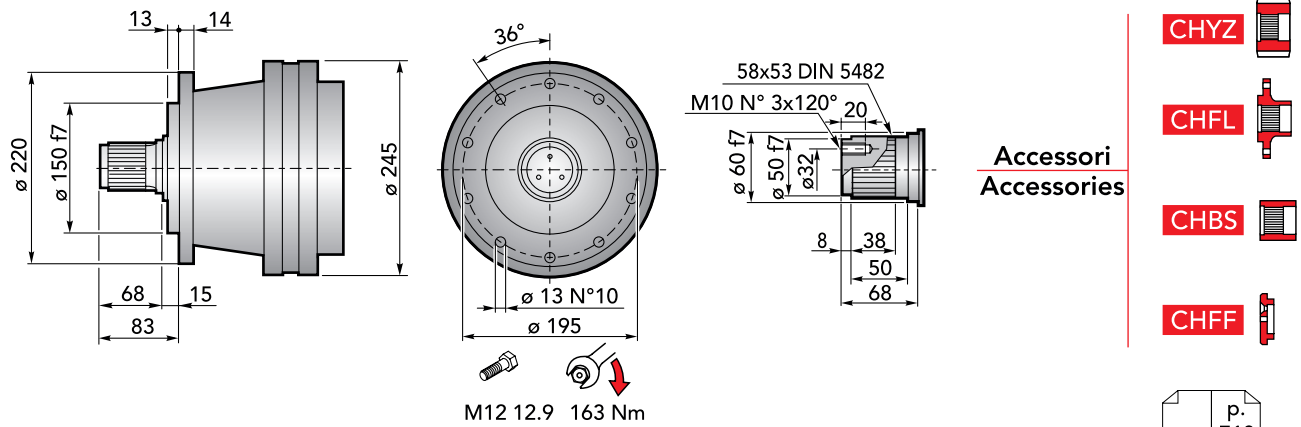

CHPL 5000 CMS - Flange motori IEC | IEC Motor flanges

CHPL	IEC 63			IEC 71			IEC 80			IEC 90			IEC 100		
	LP	P	ØD	LP	P	ØD	LP	P	ØD	LP	P	ØD	LP	P	ØD
5001	213			213			233			233			243		
5002	274			274			294			294			304		
5003	322	36	140	322	36	160	342	56	200	342	56	200	352	66	250
5004	370			370			390			390			400		

CHPL	IEC 112			IEC 132			IEC 160			IEC 180		
	LP	P	ØD	LP	P	ØD	LP	P	ØD	LP	P	ØD
5001	243			277			316			316	139	350
5002	304			338			377	139	350	-	-	-
5003	352	66	250	386	100	300	425			-	-	-
5004	400			434			-			-	-	-

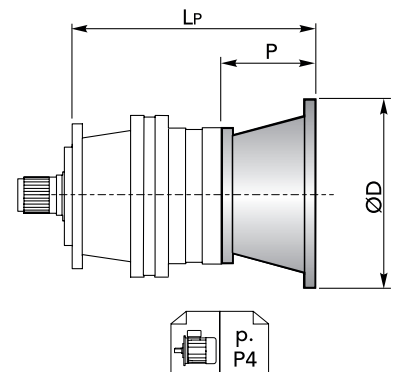

CHPL 5000 CMS - Alberi maschi entrata | Male input shafts

CHPL	CM42				CM65				CP65			
	LT	T	LE	ØE	LT	T	LE	ØE	LT	T	LE	ØE
5001	270				312	121.5	105	65 h6	343.5	153	105	65 h6
5002	331				-	-	-	-	-	-	-	-
5003	379	93	82	42 h6	-	-	-	-	-	-	-	-
5004	427				-	-	-	-	-	-	-	-

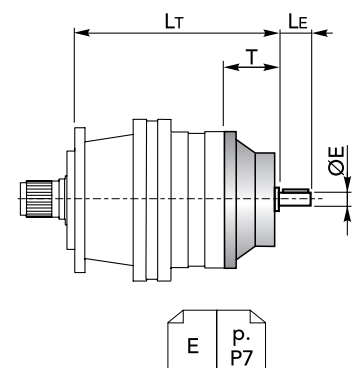



DIMENSIONI · DIMENSIONS

CHPL 5000 CMS - Riduttore a vite senza fine CHM in entrata | *CHM input worm gearboxes*

CHPL	CHM 50					CHM 63				
	Lv	I	H	M	N	Lv	I	H	M	N
5001	302.5	50	110	60	80	312	63	135	72	95
5002	363.5					373				
5003	411.5					421				
5004	459.5					469				

CHPL	CHM 75					CHM 90				
	Lv	I	H	M	N	Lv	I	H	M	N
5001	291	75	161	86	112.5	301	90	193	103	129.5
5002	352					362				
5003	400					410				
5004	448					458				

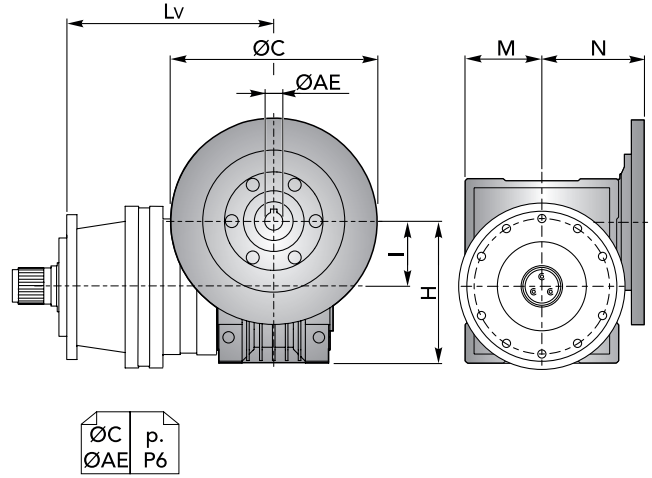

CHPL / CHPLB 5000 CMS

CHPLB 5000 CMS - Flange motori IEC | *IEC Motor flanges*

CHPLB	IEC 63				IEC 71				IEC 80				IEC 90			
	L	LP	P	ØD	L	LP	P	ØD	L	LP	P	ØD	L	LP	P	ØD
5002	278.5	276	36	140	278.5	276	36	160	278.5	296	56	200	278.5	296	56	200
5003	313	196			313	196			313	216			313	216		
5004	361				361	361			361	361			361			

CHPLB	IEC 100				IEC 112				IEC 132				IEC 160			
	L	LP	P	ØD	L	LP	P	ØD	L	LP	P	ØD	L	LP	P	ØD
5002	278.5	306	66	250	278.5	306	66	250	278.5	340	100	300	278.5	379	139	350
5003	313	226			313	226			313	260			-	-		
5004	361				361	361			361	-			-			

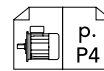
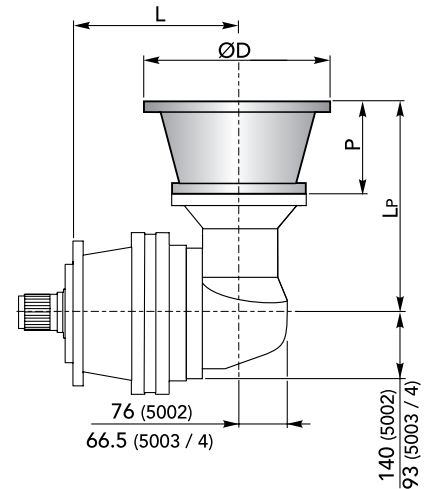

CHPLB 5000 CMS - Alberi maschi entrata | *Male input shafts*

CHPLB	CM42					CM65					CP65				
	L	Lt	T	Le	ØE	L	Lt	T	Le	ØE	L	Lt	T	Le	ØE
5002	278.5	333	93	82	42 h6	278.5	377.5	121.5	105	65 h6	278.5	409	153	105	65 h6
5003	313	253				313	297.5				313	329			
5004	361					361	361				361	361			

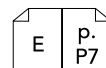
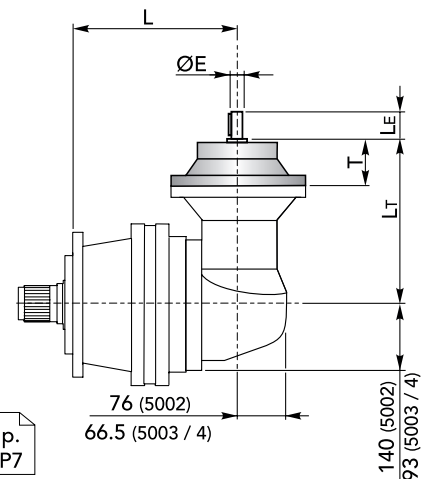

DIMENSIONI · DIMENSIONS

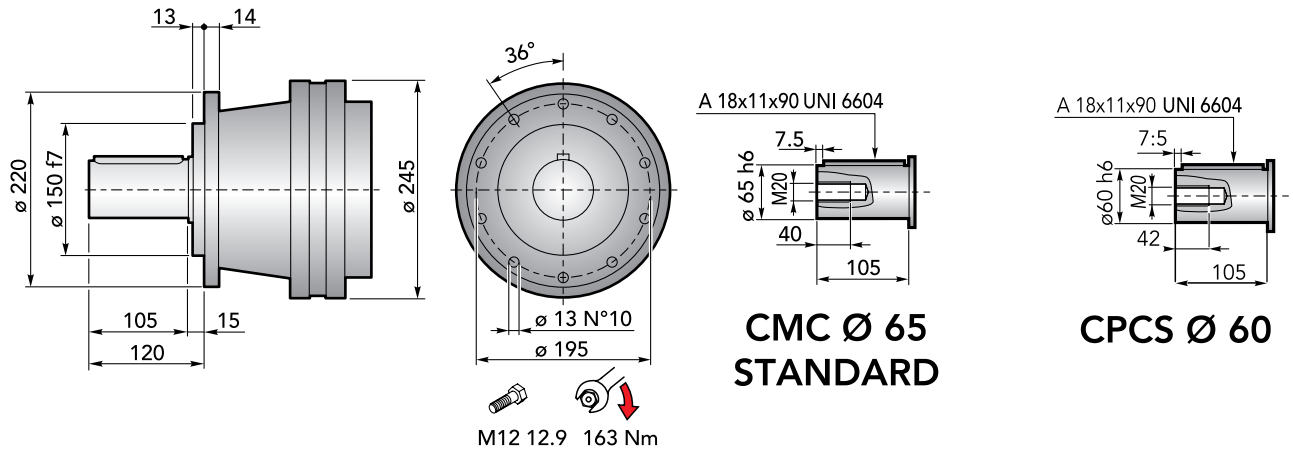

CHPL 5000 CMC - Flange motori IEC | IEC Motor flanges

CHPL	IEC 63			IEC 71			IEC 80			IEC 90			IEC 100		
	L _P	P	ØD	L _P	P	ØD	L _P	P	ØD	L _P	P	ØD	L _P	P	ØD
5001	213			213			233			233			243		
5002	274	36	140	274	36	160	294	56	200	294	56	200	304	66	250
5003	322			322			342			342			352		
5004	370			370			390			390			400		

CHPL	IEC 112			IEC 132			IEC 160			IEC 180		
	L _P	P	ØD	L _P	P	ØD	L _P	P	ØD	L _P	P	ØD
5001	243			277			316			316	139	350
5002	304	66	250	338	100	300	377	139	350	-	-	-
5003	352			386			425			-	-	-
5004	400			434			-			-	-	-

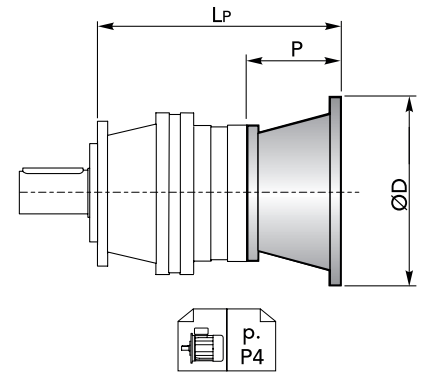

CHPL 5000 CMC - Alberi maschi entrata | Male input shafts

CHPL	CM42				CM65				CP65			
	L _T	T	L _E	ØE	L _T	T	L _E	ØE	L _T	T	L _E	ØE
5001	270				312	121.5	105	65 h6	343.5	153	105	65 h6
5002	331				-	-	-	-	-	-	-	-
5003	379	93	82	42 h6	-	-	-	-	-	-	-	-
5004	427				-	-	-	-	-	-	-	-

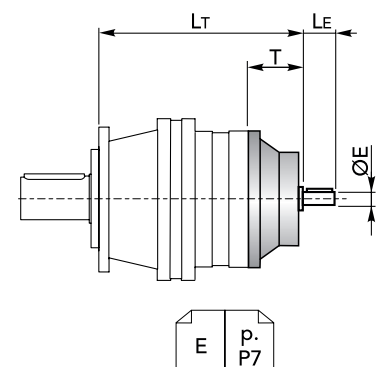



DIMENSIONI · DIMENSIONS

CHPL 5000 CMC - Riduttore a vite senza fine CHM in entrata | *CHM input worm gearboxes*

CHPL	CHM 50					CHM 63				
	Lv	I	H	M	N	Lv	I	H	M	N
5001	302.5	50	110	60	80	312	63	135	72	95
5002	363.5					373				
5003	411.5					421				
5004	459.5					469				

CHPL	CHM 75					CHM 90				
	Lv	I	H	M	N	Lv	I	H	M	N
5001	291	75	161	86	112.5	301	90	193	103	129.5
5002	352					362				
5003	400					410				
5004	448					458				

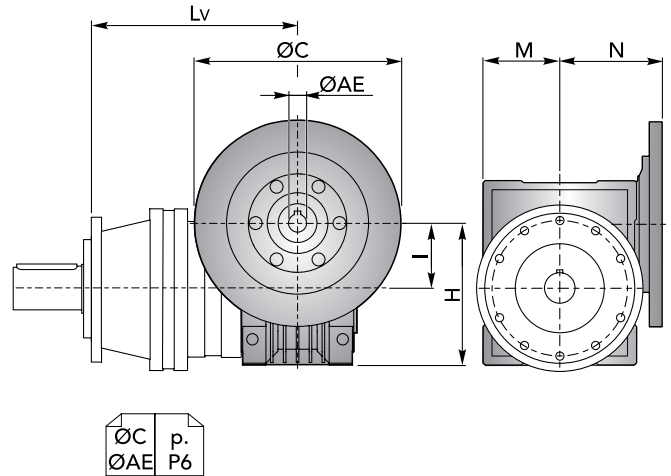

CHPL / CHPLB 5000 CMC

CHPLB 5000 CMC - Flange motori IEC | *IEC Motor flanges*

CHPLB	IEC 63				IEC 71				IEC 80				IEC 90							
	L	LP	P	ØD	L	LP	P	ØD	L	LP	P	ØD	L	LP	P	ØD				
5002	278.5	276	36	140	278.5	276	36	160	278.5	296	56	200	278.5	296	56	200				
5003	313	196			313	196			313	216			313	216			313	216	313	216
5004	361				361				361				361				361		361	

CHPLB	IEC 100				IEC 112				IEC 132				IEC 160					
	L	LP	P	ØD	L	LP	P	ØD	L	LP	P	ØD	L	LP	P	ØD		
5002	278.5	306	66	250	278.5	306	66	250	278.5	340	100	300	278.5	379	139	350		
5003	313	226			313	226			313	260			313	260	-	-	-	-
5004	361				361				361				361		-	-	-	-

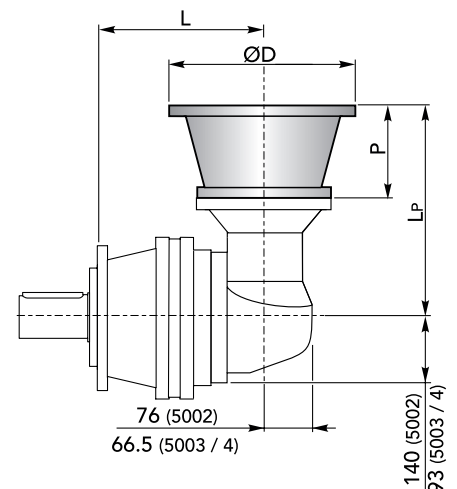

CHPLB 5000 CMC - Alberi maschi entrata | *Male input shafts*

CHPLB	CM42					CM65					CP65				
	L	LT	T	LE	ØE	L	LT	T	LE	ØE	L	LT	T	LE	ØE
5002	278.5	333	93	82	42 h6	278.5	377.5	121.5	105	65 h6	278.5	409	153	105	65 h6
5003	313	253				313	297.5				313	329			
5004	361					361					361				

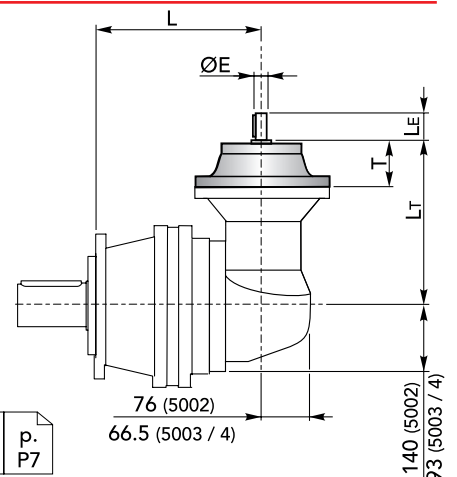

DIMENSIONI · DIMENSIONS

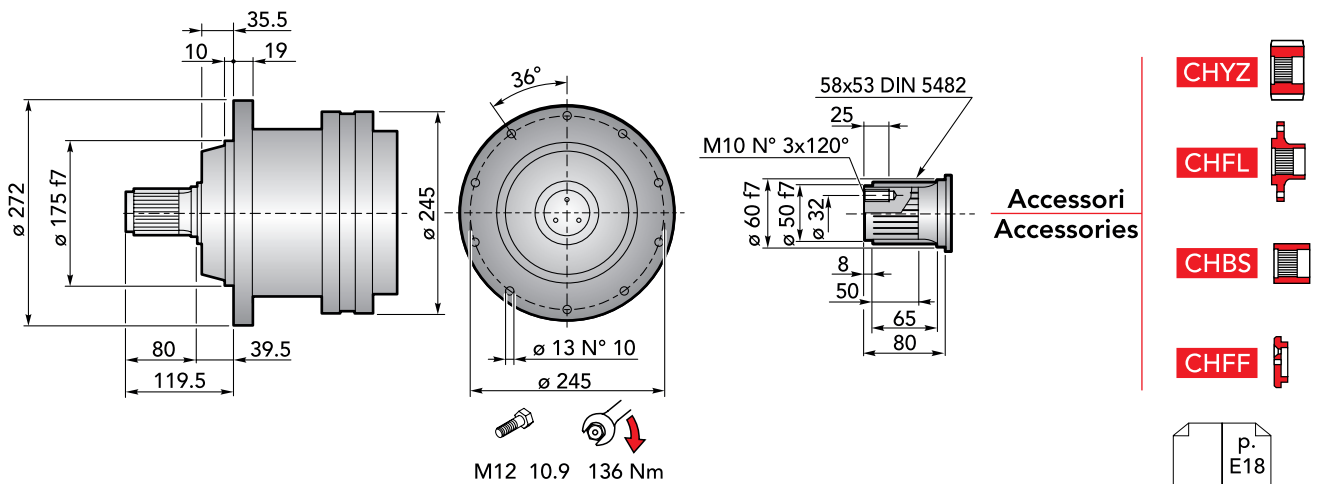

CHPL 5000 CPS - Flange motori IEC | IEC Motor flanges

CHPL	IEC 63			IEC 71			IEC 80			IEC 90			IEC 100		
	Lp	P	ØD	Lp	P	ØD	Lp	P	ØD	Lp	P	ØD	Lp	P	ØD
5001	220			220			240			240			250		
5002	281	36	140	281	36	160	301	56	200	301	56	200	311	66	250
5003	329			329			349			349			359		
5004	377			377			397			397			407		

CHPL	IEC 112			IEC 132			IEC 160			IEC 180		
	Lp	P	ØD	Lp	P	ØD	Lp	P	ØD	Lp	P	ØD
5001	250			284			323			323	139	350
5002	311	66	250	345	100	300	384	139	350	-	-	-
5003	359			393			432			-	-	-
5004	407			441			-			-	-	-

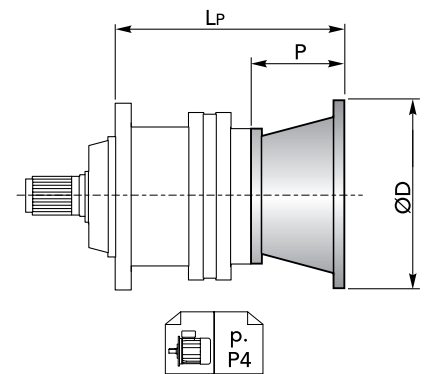

CHPL 5000 CPS - Alberi maschi entrata | Male input shafts

CHPL	CM42				CM65				CP65			
	Lt	T	Le	ØE	Lt	T	Le	ØE	Lt	T	Le	ØE
5001	277				319	121.5	105	65 h6	350.5	153	105	65 h6
5002	338	93	82	42 h6	-	-	-	-	-	-	-	-
5003	386				-	-	-	-	-	-	-	-
5004	434				-	-	-	-	-	-	-	-

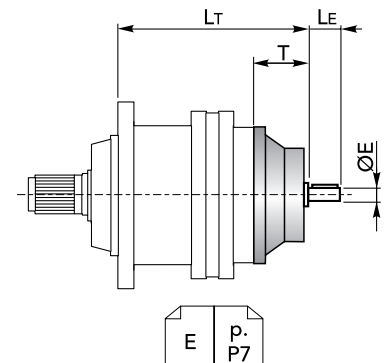



DIMENSIONI · DIMENSIONS

CHPL 5000 CPS - Riduttore a vite senza fine CHM in entrata | *CHM input worm gearboxes*

CHPL	CHM 50					CHM 63				
	Lv	I	H	M	N	Lv	I	H	M	N
5001	309.5	50	110	60	80	319	63	135	72	95
5002	370.5					380				
5003	418.5					428				
5004	466.5					476				

CHPL	CHM 75					CHM 90				
	Lv	I	H	M	N	Lv	I	H	M	N
5001	298	75	161	86	112.5	308	90	193	103	129.5
5002	359					369				
5003	407					417				
5004	455					465				

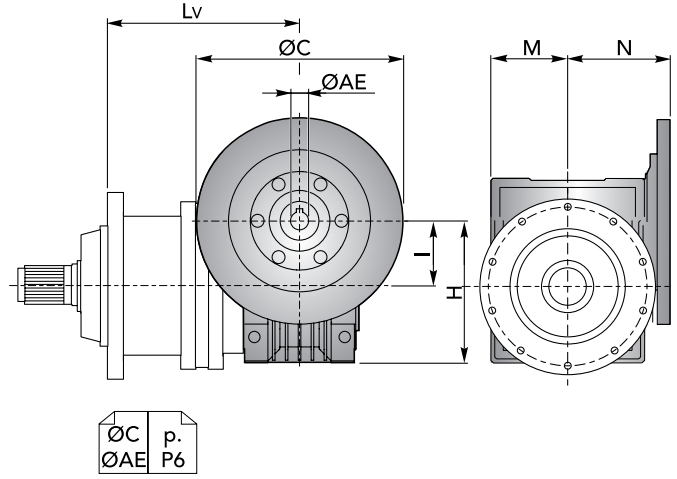

CHPL / CHPLB 5000 CPS

CHPLB 5000 CPS - Flange motori IEC | *IEC Motor flanges*

CHPLB	IEC 63				IEC 71				IEC 80				IEC 90			
	L	LP	P	ØD	L	LP	P	ØD	L	LP	P	ØD	L	LP	P	ØD
5002	285.5	276	36	140	285.5	276	36	160	285.5	296	56	200	285.5	296	56	200
5003	320	196			320	196			320	216			320	216		
5004	368				368	368			368	368			368			

CHPLB	IEC 100				IEC 112				IEC 132				IEC 160			
	L	LP	P	ØD	L	LP	P	ØD	L	LP	P	ØD	L	LP	P	ØD
5002	285.5	306	66	250	285.5	306	66	250	285.5	340	260	300	285.5	379	139	350
5003	320	226			320	226			320	320			-			
5004	368				368	368			368	-			-			

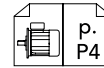
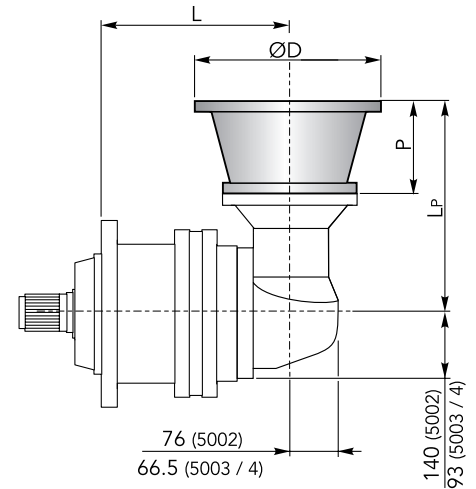

CHPLB 5000 CPS - Alberi maschi entrata | *Male input shafts*

CHPLB	CM42					CM65					CP65				
	L	LT	T	Le	ØE	L	LT	T	Le	ØE	L	LT	T	Le	ØE
5002	285.5	333	93	82	42 h6	285.5	377.5	121.5	105	65 h6	285.5	409	153	105	65 h6
5003	320	253				320	297.5				320	329			
5004	368					368	368				368	368			

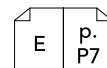
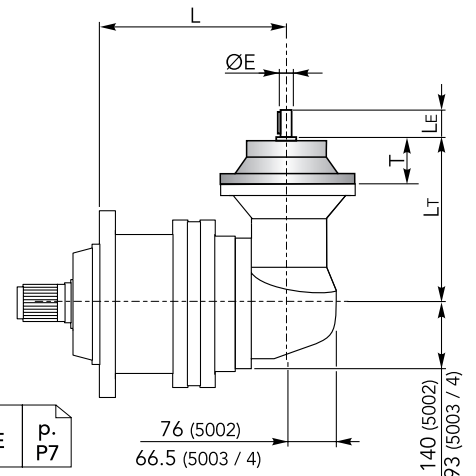

DIMENSIONI · DIMENSIONS

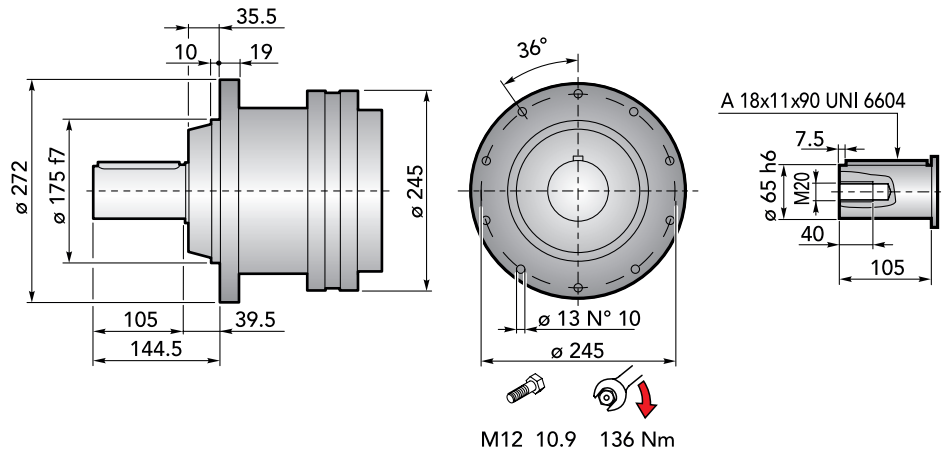

CHPL 5000 CPC - Flange motori IEC | IEC Motor flanges

CHPL	IEC 63			IEC 71			IEC 80			IEC 90			IEC 100		
	LP	P	ØD	LP	P	ØD	LP	P	ØD	LP	P	ØD	LP	P	ØD
5001	220			220			240			240			250		
5002	281	36	140	281	36	160	301	56	200	301	56	200	311	66	250
5003	329			329			349			349			359		
5004	377			377			397			397			407		

CHPL	IEC 112			IEC 132			IEC 160			IEC 180				
	LP	P	ØD	LP	P	ØD	LP	P	ØD	LP	P	ØD		
5001	250			284			323			323	139	350		
5002	311	66	250	345	100	300	384	139	350	-				
5003	359			393			432			-				
5004	407			441			-			-				

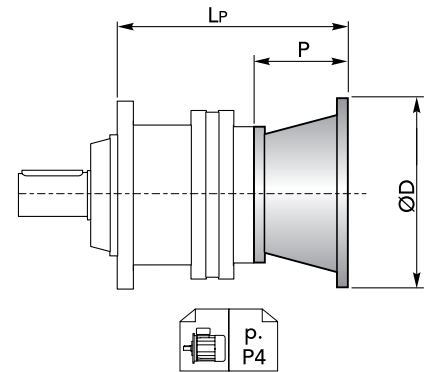

CHPL 5000 CPC - Alberi maschi entrata | Male input shafts

CHPL	CM42				CM65				CP65			
	LT	T	LE	ØE	LT	T	LE	ØE	LT	T	LE	ØE
5001	277				319	121.5	105	65 h6	350.5	153	105	65 h6
5002	338	93	82	42 h6	-				-			
5003	386				-				-			
5004	434				-				-			

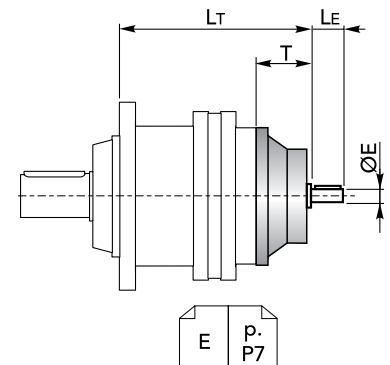



DIMENSIONI · DIMENSIONS

CHPL 5000 CPC - Riduttore a vite senza fine CHM in entrata | *CHM input worm gearboxes*

CHPL	CHM 50					CHM 63				
	Lv	I	H	M	N	Lv	I	H	M	N
5001	309.5	50	110	60	80	319	63	135	72	95
5002	370.5					380				
5003	418.5					428				
5004	466.5					476				

CHPL	CHM 75					CHM 90				
	Lv	I	H	M	N	Lv	I	H	M	N
5001	298	75	161	86	112.5	308	90	193	103	129.5
5002	359					369				
5003	407					417				
5004	455					465				

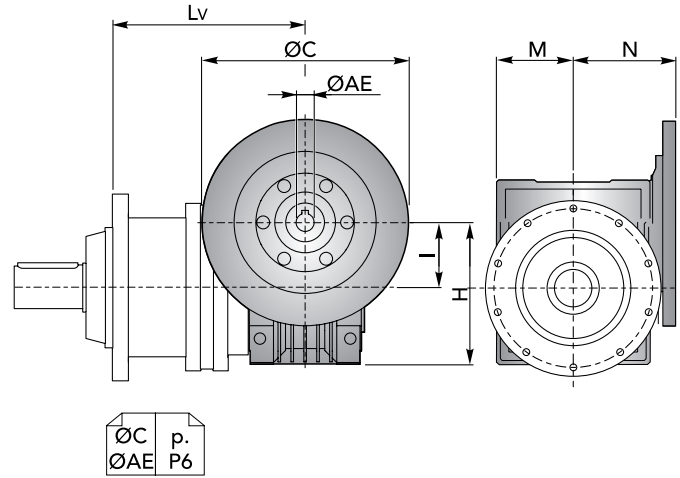

CHPL / CHPLB 5000 CPC

CHPLB 5000 CPC - Flange motori IEC | *IEC Motor flanges*

CHPLB	IEC 63				IEC 71				IEC 80				IEC 90			
	L	LP	P	ØD	L	LP	P	ØD	L	LP	P	ØD	L	LP	P	ØD
5002	285.5	276	36	140	285.5	276	36	160	285.5	296	56	200	285.5	296	56	200
5003	320	196			320	196			320	216			320	216		
5004	368				368	368			368	368			368	368		

CHPLB	IEC 100				IEC 112				IEC 132				IEC 160			
	L	LP	P	ØD	L	LP	P	ØD	L	LP	P	ØD	L	LP	P	ØD
5002	285.5	306	66	250	285.5	306	66	250	285.5	340	260	300	285.5	379	139	350
5003	320	226			320	226			320	300			-			
5004	368				368	368			368	368			-			

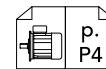
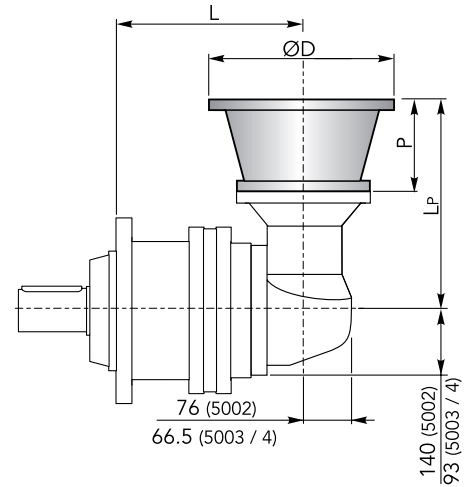

CHPLB 5000 CPC - Alberi maschi entrata | *Male input shafts*

CHPLB	CM42					CM65					CP65				
	L	L _T	T	L _E	ØE	L	L _T	T	L _E	ØE	L	L _T	T	L _E	ØE
5002	285.5	333	93	82	42 h6	285.5	377.5	121.5	105	65 h6	285.5	409	153	105	65 h6
5003	320	253				320	297.5				320	329			
5004	368					368	368				368	368			

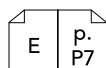
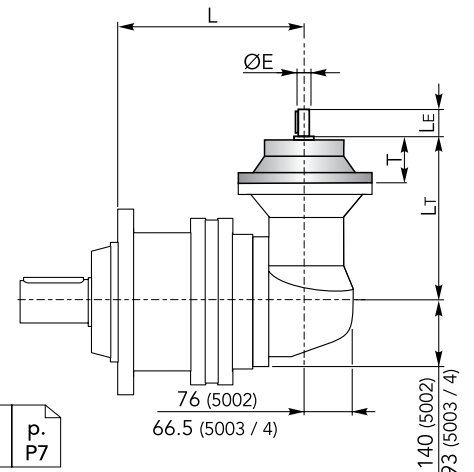

DIMENSIONI · DIMENSIONS

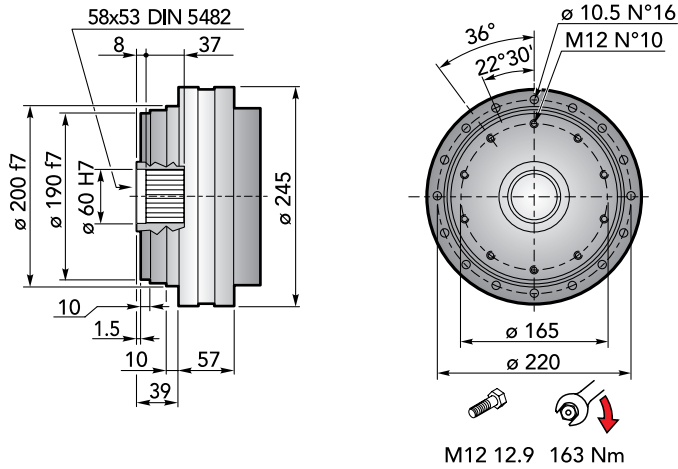
Accessori
Accessories

CHKB

P.
E18

CHPL 5000 CF - Flange motori IEC | IEC Motor flanges

CHPL	IEC 63			IEC 71			IEC 80			IEC 90			IEC 100		
	Lp	P	ØD	Lp	P	ØD	Lp	P	ØD	Lp	P	ØD	Lp	P	ØD
5001	126.5	36	140	126.5	36	160	146.5	56	200	146.5	56	200	156.5	66	250
5002	187.5			187.5			207.5			207.5			217.5		
5003	235.5			235.5			255.5			255.5			265.5		
5004	283.5			283.5			303.5			303.5			313.5		

CHPL	IEC 112			IEC 132			IEC 160			IEC 180		
	Lp	P	ØD	Lp	P	ØD	Lp	P	ØD	Lp	P	ØD
5001	156.5	66	250	190.5	100	300	229.5	139	350	229.5	139	350
5002	217.5			251.5			-					
5003	265.5			299.5			-					
5004	313.5			347.5			-					

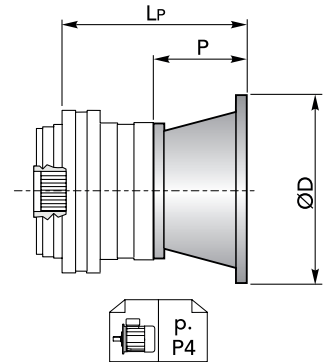

CHPL 5000 CF - Alberi maschi entrata | Male input shafts

CHPL	CM42				CM65				CP65			
	Lt	T	LE	ØE	Lt	T	LE	ØE	Lt	T	LE	ØE
5001	183.5	93	82	42 h6	225.5	121.5	105	65 h6	257	153	105	65 h6
5002	244.5				-	-	-					
5003	292.5				-	-	-					
5004	340.5				-	-	-					

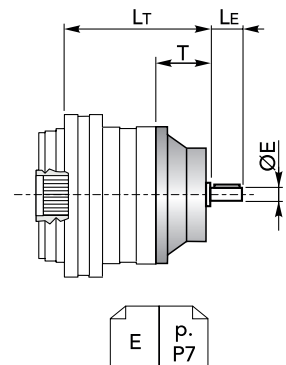



DIMENSIONI · DIMENSIONS

CHPL 5000 CF - Riduttore a vite senza fine CHM in entrata | CHM input worm gearboxes

CHPL	CHM 50					CHM 63				
	Lv	I	H	M	N	Lv	I	H	M	N
5001	216	50	110	60	80	225.5	63	135	72	95
5002	277					286.5				
5003	325					334.5				
5004	373					382.5				

CHPL	CHM 75					CHM 90				
	Lv	I	H	M	N	Lv	I	H	M	N
5001	204.5	75	161	86	112.5	214.5	90	193	103	129.5
5002	265.5					275.5				
5003	313.5					323.5				
5004	361.5					371.5				

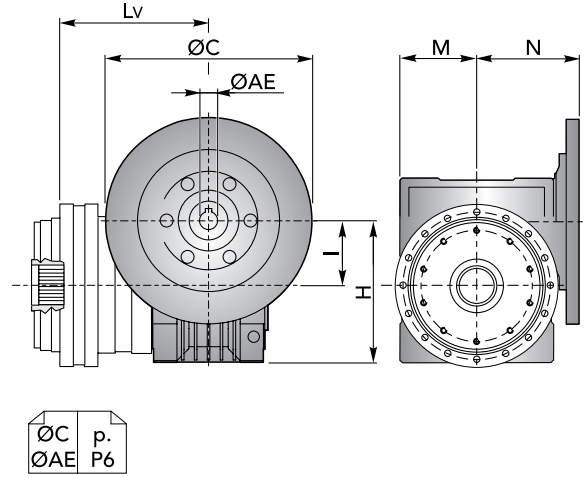

CHPL / CHPLB 5000 CF

CHPLB 5000 CF - Flange motori IEC | IEC Motor flanges

CHPLB	IEC 63				IEC 71				IEC 80				IEC 90			
	L	Lp	P	ØD	L	Lp	P	ØD	L	Lp	P	ØD	L	Lp	P	ØD
5002	192	276	36	140	192	276	36	160	192	296	56	200	192	296	56	200
5003	226.5	196			226.5	196			226.5	216			226.5	216		
5004	274.5				274.5				274.5				274.5			

CHPLB	IEC 100				IEC 112				IEC 132				IEC 160			
	L	Lp	P	ØD	L	Lp	P	ØD	L	Lp	P	ØD	L	Lp	P	ØD
5002	192	306	66	250	192	306	66	250	192	340	100	300	192	379	139	350
5003	226.5	226			226.5	226			226.5	260			-			
5004	274.5				274.5				274.5				-			

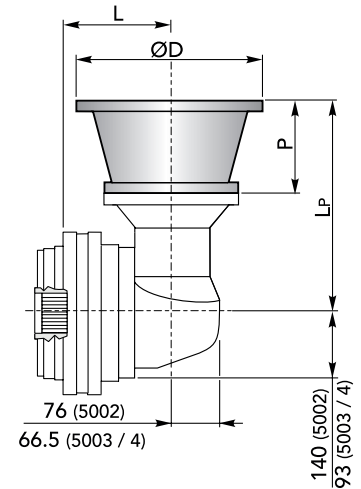

CHPLB 5000 CF - Alberi maschi entrata | Male input shafts

CHPLB	CM42					CM65					CP65				
	L	Lt	T	Le	ØE	L	Lt	T	Le	ØE	L	Lt	T	Le	ØE
5002	192	333	93	82	42 h6	192	377.5	121.5	105	65 h6	192	409	153	105	65 h6
5003	226.5	253				226.5	297.5				226.5	329			
5004	274.5					274.5					274.5				

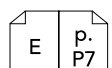
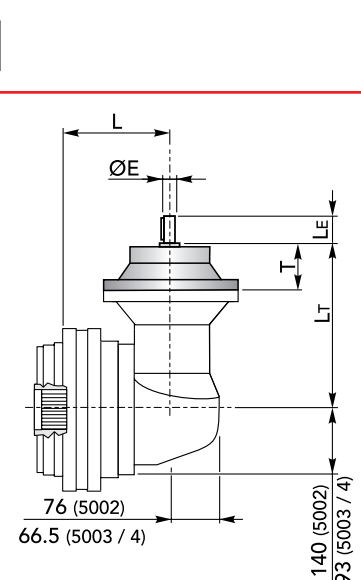

DIMENSIONI · DIMENSIONS

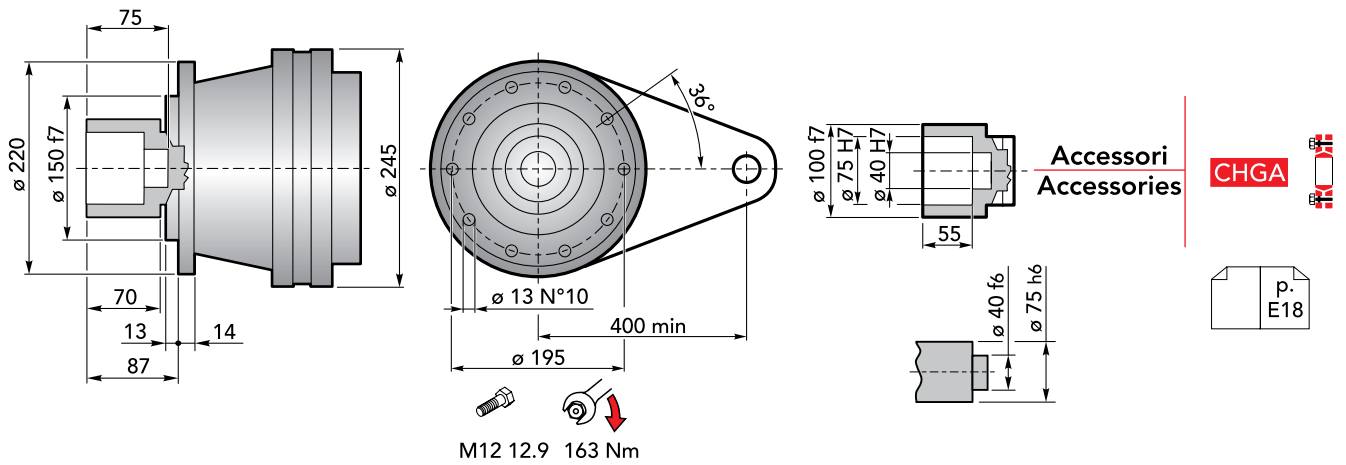

CHPL 5000 CFS - Flange motori IEC | IEC Motor flanges

CHPL	IEC 63			IEC 71			IEC 80			IEC 90			IEC 100		
	LP	P	ØD	LP	P	ØD	LP	P	ØD	LP	P	ØD	LP	P	ØD
5001	213			213			233			233			243		
5002	274			274			294			294			304		
5003	322	36	140	322	36	160	342	56	200	342	56	200	352	66	250
5004	370			370			390			390			400		

CHPL	IEC 112			IEC 132			IEC 160			IEC 180		
	LP	P	ØD	LP	P	ØD	LP	P	ØD	LP	P	ØD
5001	243			277			316			316	139	350
5002	304			338			377	139	350	-		
5003	352	66	250	386	100	300	425			-		
5004	400			434			-			-		

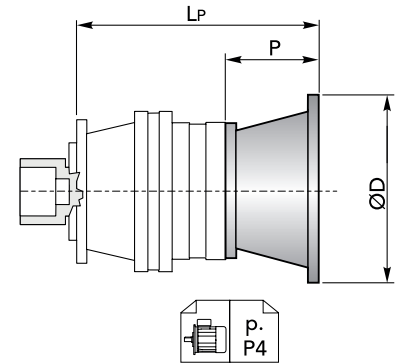

CHPL 5000 CFS - Alberi maschi entrata | Male input shafts

CHPL	CM42				CM65				CP65			
	LT	T	LE	ØE	LT	T	LE	ØE	LT	T	LE	ØE
5001	270				312	121.5	105	65 h6	343.5	153	105	65 h6
5002	331				-				-			
5003	379	93	82	42 h6	-				-			
5004	427				-				-			

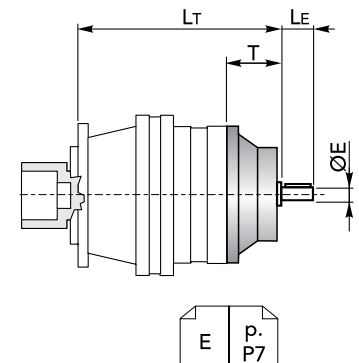



DIMENSIONI · DIMENSIONS

CHPL 5000 CFS - Riduttore a vite senza fine CHM in entrata | *CHM input worm gearboxes*

CHPL	CHM 50					CHM 63				
	Lv	I	H	M	N	Lv	I	H	M	N
5001	302.5	50	110	60	80	312	63	135	72	95
5002	363.5					373				
5003	411.5					421				
5004	459.5					469				

CHPL	CHM 75					CHM 90				
	Lv	I	H	M	N	Lv	I	H	M	N
5001	291	75	161	86	112.5	301	90	193	103	129.5
5002	352					362				
5003	400					410				
5004	448					458				

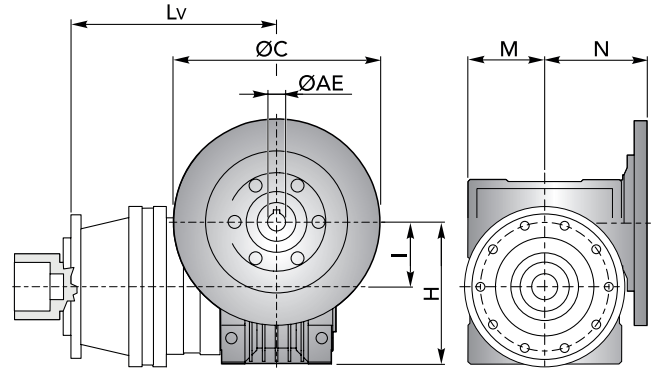

CHPL / CHPLB 5000 CFS

CHPLB 5000 CFS - Flange motori IEC | *IEC Motor flanges*

CHPLB	IEC 63				IEC 71				IEC 80				IEC 90			
	L	LP	P	ØD	L	LP	P	ØD	L	LP	P	ØD	L	LP	P	ØD
5002	278.5	276	36	140	278.5	276	36	160	278.5	296	56	200	278.5	296	56	200
5003	313	196			313	196			313	216			313	216		
5004	361				361	361			361	361			361			

CHPLB	IEC 100				IEC 112				IEC 132				IEC 160			
	L	LP	P	ØD	L	LP	P	ØD	L	LP	P	ØD	L	LP	P	ØD
5002	278.5	306	66	250	278.5	306	66	250	278.5	340	100	300	278.5	379	139	350
5003	313	226			313	226			313	260			-			
5004	361				361	361			361	-						

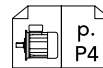
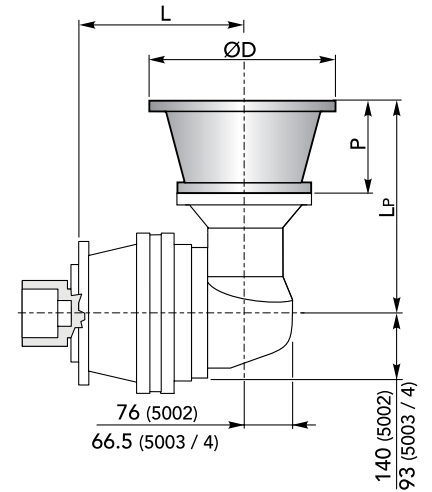

CHPLB 5000 CFS - Alberi maschi entrata | *Male input shafts*

CHPLB	CM42					CM65					CP65				
	L	LT	T	LE	ØE	L	LT	T	LE	ØE	L	LT	T	LE	ØE
5002	278.5	333	93	82	42 h6	278.5	377.5	121.5	105	65 h6	278.5	409	153	105	65 h6
5003	313	253				313	297.5				313	329			
5004	361					361	361				361	361			

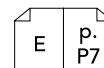
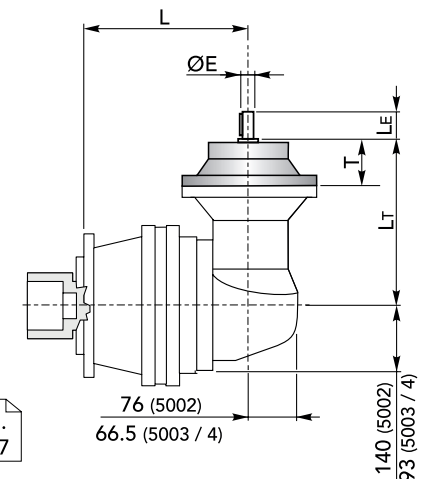

DIMENSIONI · DIMENSIONS

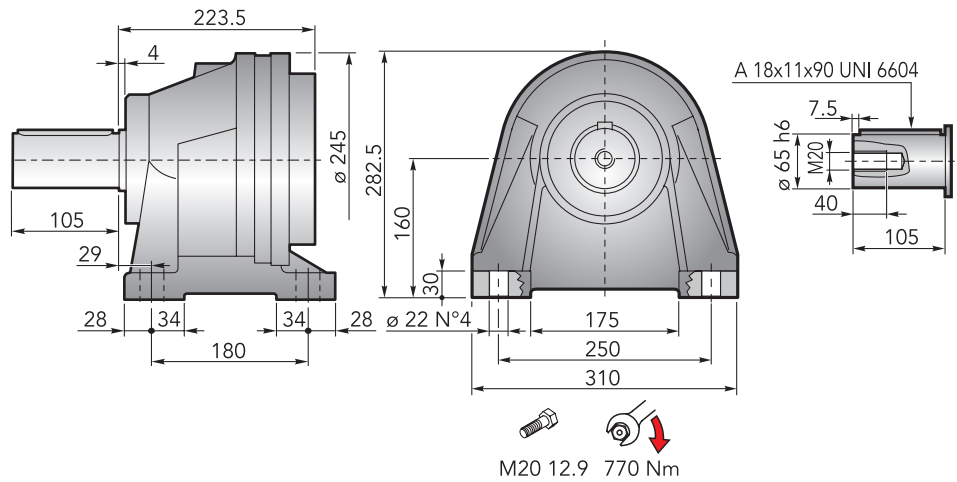

CHPL 5000 CCPC - Flange motori IEC | IEC Motor flanges

CHPL	IEC 63			IEC 71			IEC 80			IEC 90			IEC 100		
	LP	P	ØD	LP	P	ØD	LP	P	ØD	LP	P	ØD	LP	P	ØD
5001	259.5	36	140	259.5	36	160	279.5	56	200	279.5	56	200	289.5	66	250
5002	320.5			320.5			340.5			340.5			350.5		
5003	368.5			368.5			388.5			388.5			398.5		
5004	416.5			416.5			436.5			436.5			446.5		

CHPL	IEC 112			IEC 132			IEC 160			IEC 180		
	LP	P	ØD	LP	P	ØD	LP	P	ØD	LP	P	ØD
5001	289.5	66	250	323.5	100	300	362.5	139	350	362.5	-	-
5002	350.5			384.5			423.5			-		
5003	398.5			432.5			471.5			-		
5004	446.5			480.5			-			-		

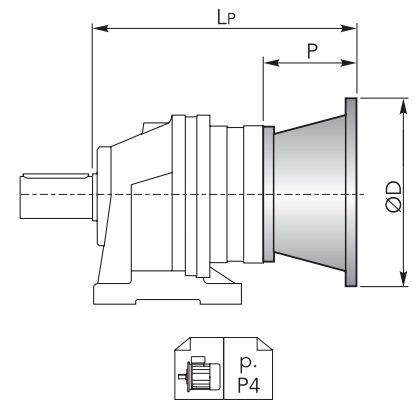

CHPL 5000 CCPC - Alberi maschi entrata | Male input shafts

CHPL	CM42				CM65				CP65			
	LT	T	LE	ØE	LT	T	LE	ØE	LT	T	LE	ØE
5001	316.5	93	82	42 h6	358.5	121.5	105	65 h6	390	153	105	65 h6
5002	377.5				-	-	-					
5003	425.5				-	-	-					
5004	473.5				-	-	-					

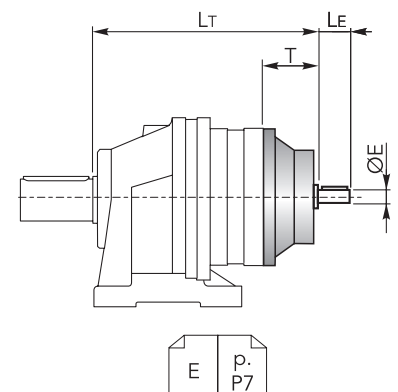



DIMENSIONI · DIMENSIONS

CHPL 5000 CCPC - Riduttore a vite senza fine CHM in entrata | *CHM input worm gearboxes*

CHPL	CHM 50					CHM 63				
	Lv	I	H	M	N	Lv	I	H	M	N
5001	349	50	110	60	80	358.5	63	135	72	95
5002	410					419.5				
5003	458					467.5				
5004	506					515.5				

CHPL	CHM 75					CHM 90				
	Lv	I	H	M	N	Lv	I	H	M	N
5001	337.5	75	161	86	112.5	347.5	90	193	103	129.5
5002	398.5					408.5				
5003	446.5					456.5				
5004	494.5					504.5				

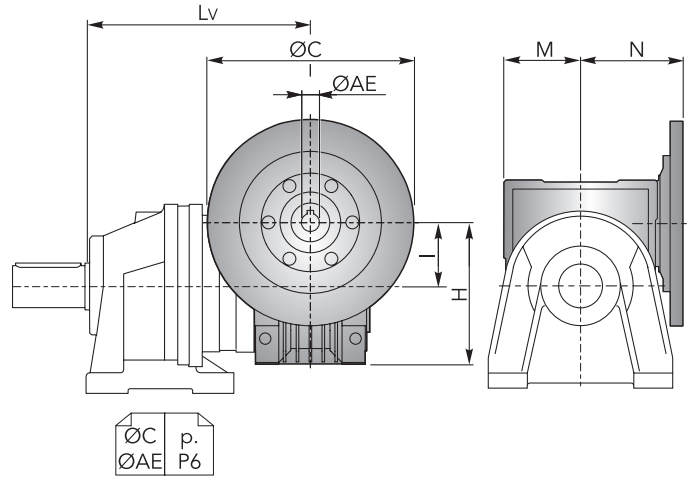

CHPLB 5000 CCPC - Flange motori IEC | *IEC Motor flanges*

CHPLB	IEC 63				IEC 71				IEC 80				IEC 90			
	L	LP	P	ØD	L	LP	P	ØD	L	LP	P	ØD	L	LP	P	ØD
5002	325	276	36	140	325	276	36	160	325	296	56	200	325	296	56	200
5003	359.5	196			359.5	196			359.5	216			359.5	216		
5004	407.5				407.5				407.5				407.5			

CHPLB	IEC 100				IEC 112				IEC 132				IEC 160			
	L	LP	P	ØD	L	LP	P	ØD	L	LP	P	ØD	L	LP	P	ØD
5002	325	306	66	250	325	306	66	250	325	340	100	300	325	379	139	350
5003	359.5	226			359.5	226			-	-						
5004	407.5				407.5				-	-						

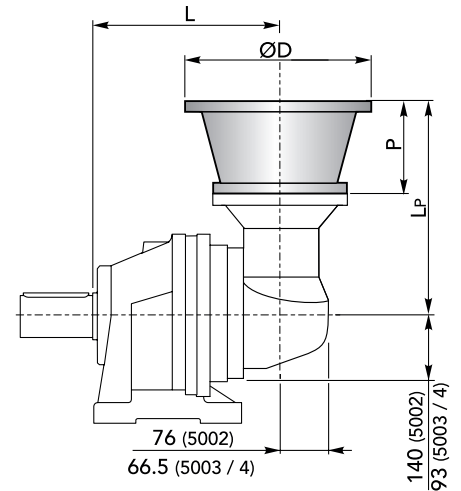

CHPLB 5000 CCPC - Alberi maschi entrata | *Male input shafts*

CHPLB	CM42					CM65					CP65				
	L	L _T	T	L _E	ØE	L	L _T	T	L _E	ØE	L	L _T	T	L _E	ØE
5002	325	333	93	82	42 h6	325	377.5	121.5	105	65 h6	325	409	153	105	65 h6
5003	359.5	253				359.5	297.5				359.5	329			
5004	407.5					407.5					407.5				

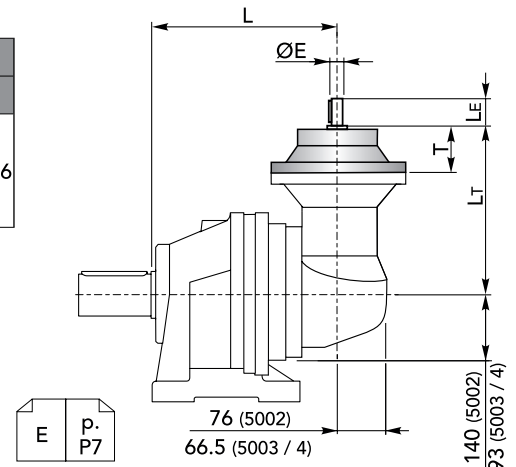

ACCESSORI · ACCESSORIES

CHYZ



Pignoni | Pinions

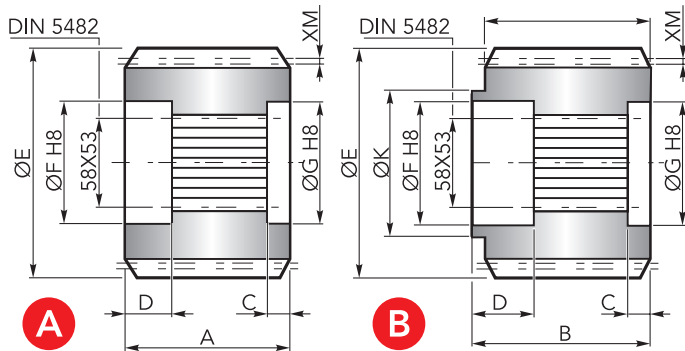

	Uscita / Output	DIN 5482											Codice / Code
		M	Z	XM	A	B	C	D	E	F	G	K	
A	CMS	8	13	0	68	-	8.5	22.5	120	60	60	-	1071.218.042
	CMS	8	11	5	68	-	8.5	22.5	110.8	60	60	-	1071.258.042
	CMS	8	12	0	68	-	8	21	112.8	60	60	-	1071.196.042
	CMS	8	15	0	68	-	8.5	22.5	136	60	60	-	1071.163.042
	CPS	6	14	3	95	.	23	21	99.6	60	60	-	1071.160.042
	CPS	10	11	8	90	-	8.5	22.5	142.1	60	60	-	1071.297.042
B	CPS	10	14	3.2	103	116	9.5	22.5	162.4	60	60	105	1071.298.042

CHFF

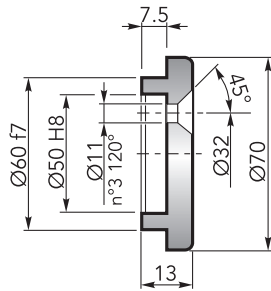

Fondello di arresto | Stop bottom plate

Codice / Code:
1075.015.000

CHBS



Boccola scanalata | Splined bushing

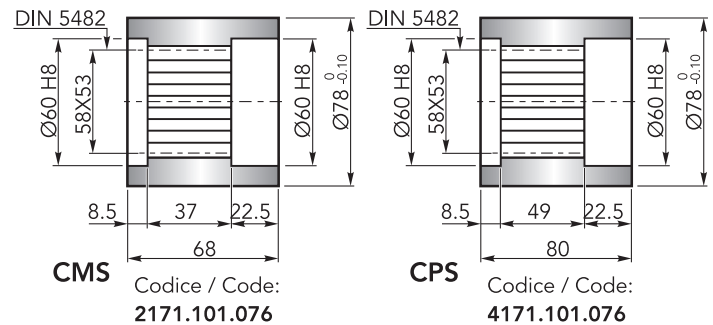

CHKB

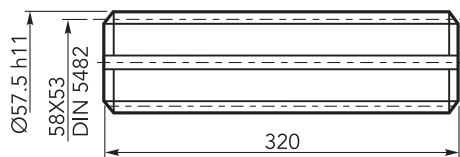

Barra scanalata | Splined rod

Codice / Code:
3071.181.042

CHGA

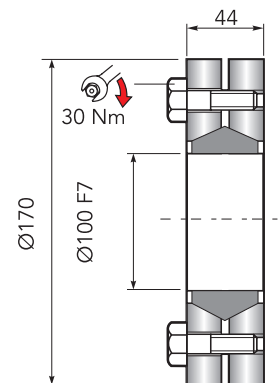

Giunto di attrito | Shrink disc

Codice / Code:
5109.100.000Coppia max: 7500 Nm (1)
Max Torque: 7500 Nm (1)(1): Coppia max indicata è valida solo con calettatori forniti da Chiaravalli S.p.A.
(1): The maximum torque indicated is valid only with shrink discs supplied by Chiaravalli S.p.A.

CHFL



Flangia | Flange

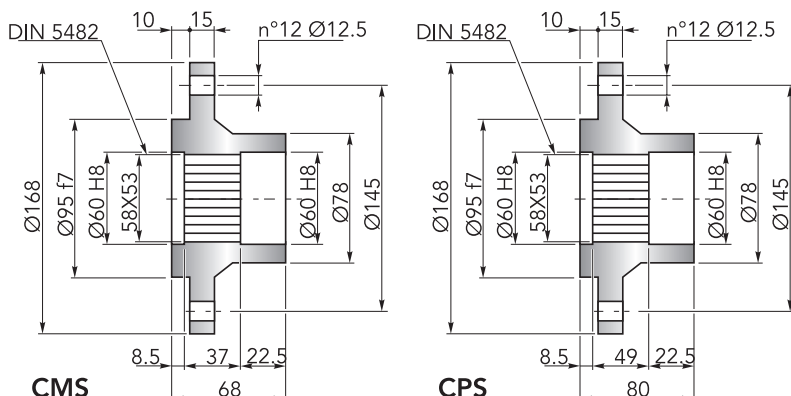

CMS

Codice / Code:
2171.103.025

CPS

Codice / Code:
4171.103.098



CARICHI RADIALI (Fr) · RADIAL LOADS (Fr)

Nel diagramma seguente, sono indicati i carichi radiali Fr (N) applicabili sull'albero uscita in funzione della distanza di applicazione L rispetto alla battuta dell'albero.

The hereunder table shows the allowable radial loads Fr (N) on the output shaft with reference to the distance L.

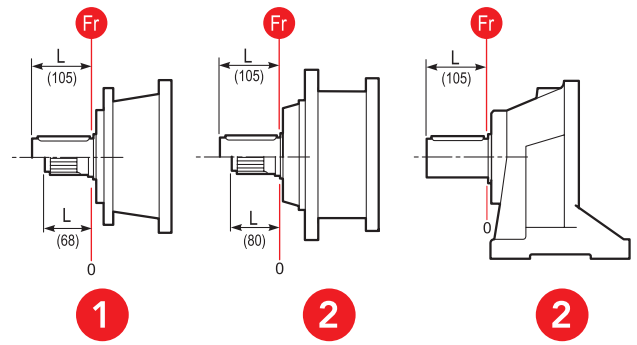
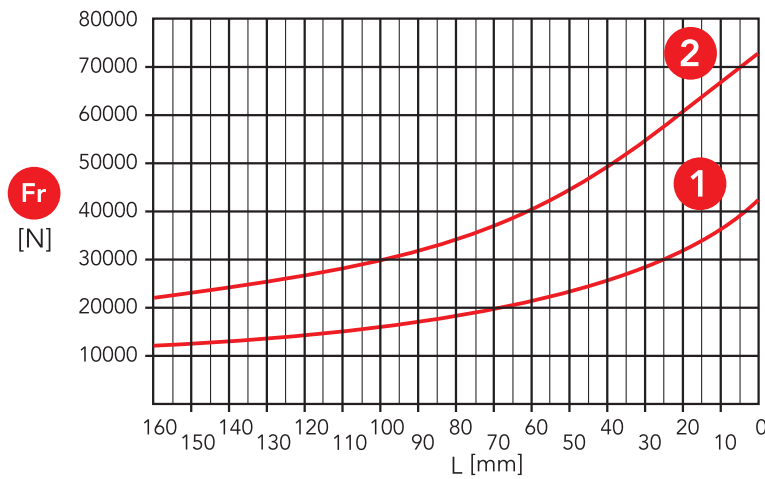

- 1 Uscita / Output: CMS, CMC
- 2 Uscita / Output: CPS, CPC, CCPC

CARICHI ASSIALI (Fa) · AXIAL LOADS (Fa)

Nella tabella seguente sono indicati i carichi assiali Fa (N) applicabili sull'albero di uscita in funzione della direzione di applicazione del carico e della versione.

The hereunder table shows the allowable axial loads Fa (N) on the output shaft with reference to the load direction and the output type.

	1	2	
Fa [N]	32000	32000	←
	32000	48000	→

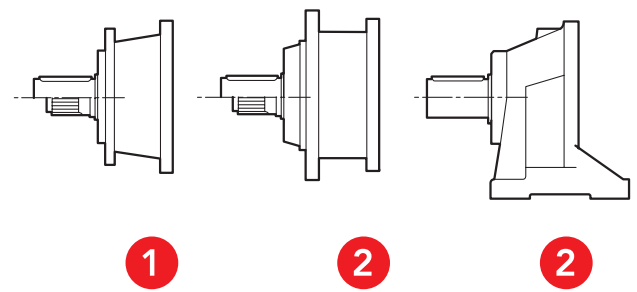

- 1 Uscita / Output: CMS, CMC
- 2 Uscita / Output: CPS, CPC, CCPC

CHPL / CHPLB 5000

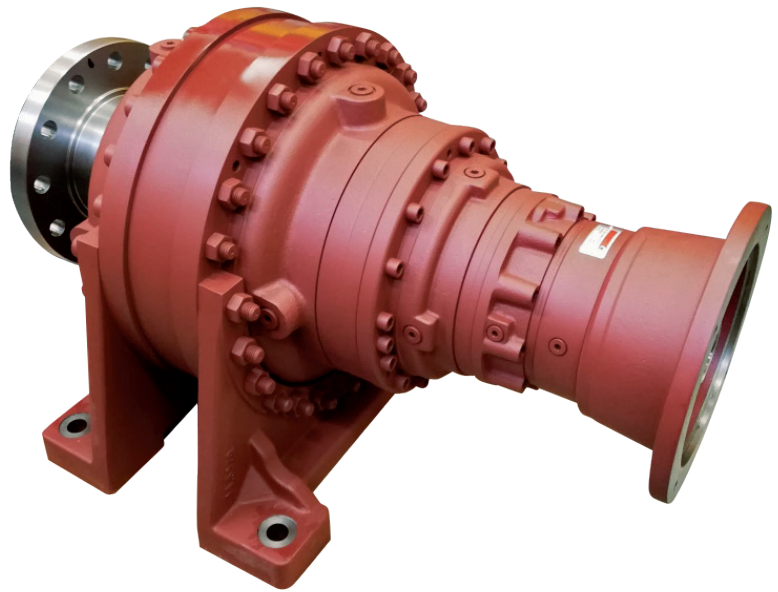



CHPL

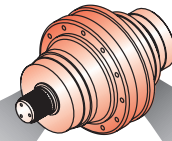

OUT

IN

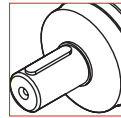

Ø80

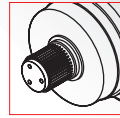

70x64
DIN 5482

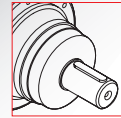

Ø42
Ø65

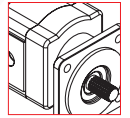

Hydraulic
Motor

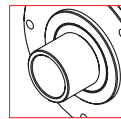

Ø90

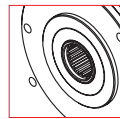

70x64
DIN 5482

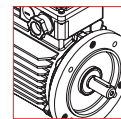

Electric
Motor

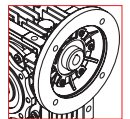

Worm
gearboxes

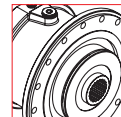

Brake

7001	i 3.67 ÷ 7.00	1 reduction stage
7002	13.9 ÷ 50.8	2 reduction stages
7003	53.8 ÷ 342.6	3 reduction stages
7004	301.1 ÷ 2968.9	4 reduction stages

CHPLB

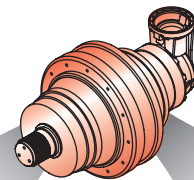

OUT

IN

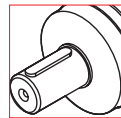

Ø80

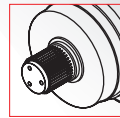

70x64
DIN 5482

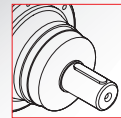

Ø42
Ø65

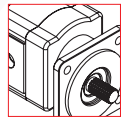

Hydraulic
Motor

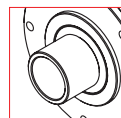

Ø90

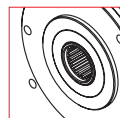

70x64
DIN 5482

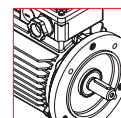

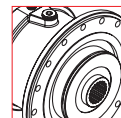

Electric
Motor



Brake

7002	i 12.7 ÷ 38.1	2 reduction stages
7003	53.6 ÷ 148.9	3 reduction stages
7004	157.7 ÷ 1069.0	4 reduction stages

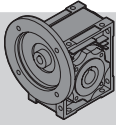

DATI TECNICI · TECHNICAL DATA

CHPL	i	T _{2n} (n ₁ = 1400 rpm) 10.000h FS=1 [Nm]	P _{1n} (n ₁ = 1400 rpm) 10.000h FS=1 [kW]	T ₂ Max [Nm]	P _t 1400 rpm [kW]	IEC		 CHM	 CM/CP
						(B5)			
7001	3.67	2935	121.5	14320	30	160 200	180	CHM 110	CM65 CP65
	4.43	2698	92.5	13080					
	5	2468	75	11480					
	5.8	2184	57.2	9720					
	7	1826	39.6	7860					
7002	13.9	3707	42	14320	18	63 80 100 132 180	71 90 112 160	CHM 50 CHM 63 CHM 75 CHM 90 CHM 110	CM42 CM65 CP65
	18.3	3488	30	13080					
	20.6	3141	24	11480					
	22.9	3710	25.5	13080					
	26.6	3801	22.5	13080					
	30	3430	18	11480					
	36.3	3458	15	11480					
	42.1	3009	11.25	9720					
	50.8	2662	8.25	7860					
7003	53.8	4717	14.3	14320	14	63 80 100 132	71 90 112 160	CHM 50 CHM 63 CHM 75 CHM 90	CM42
	64.8	4807	12.1	14320					
	71.7	4593	10.45	13080					
	78.3	4488	9.35	13080					
	88.4	4065	7.5	11480					
	93.7	4825	8.4	13080					
	102.1	5259	8.4	14320					
	112.9	4775	6.9	13080					
	127.9	5410	6.9	14320					
	139.2	4505	5.28	11480					
	148.8	5018	5.5	13080					
	155.4	4402	4.62	11480					
	174.4	4652	4.35	11480					
	194.9	3942	3.3	9720					
	216.7	5382	4.05	13080					
	244.7	4785	3.19	11480					
283.8	4211	2.42	9720						
342.6	3465	1.65	7860						
7004	301.1	6413	3.6	14320	8	63 80 100 132	71 90 112	CHM 50 CHM 63 CHM 75 CHM 90	CM42
	332.4	6488	3.3	14320					
	347.9	6483	3.15	14320					
	400.7	6399	2.7	14320					
	434.4	6552	2.55	14320					
	474.3	6735	2.4	14320					
	523.6	6969	2.25	14320					
	571.7	7101	2.1	14320					
	632.4	6454	1.73	13080					
	661.9	6462	1.65	13080					
	747.3	5967	1.35	11480					
	768.7	6820	1.5	13080					
	832.3	7017	1.43	13080					
	870	6176	1.2	11480					
	976.5	6065	1.05	11480					
	1048.7	6517	1.05	11480					
	1177	6267	0.9	11480					
	1366.9	6671	0.85	11480					
	1651.6	6595	0.68	11480					
2968.9	5270	0.3	7860						

n_{1max} = 2800 rpm

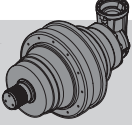

DATI TECNICI · TECHNICAL DATA

 CHPLB	i	T _{2n} (n ₁ = 1400 rpm) 10.000h FS=1 [Nm]	P _{1n} (n ₁ = 1400 rpm) 10.000h FS=1 [kW]	T ₂ Max [Nm]	P _t 1400 rpm [kW]	IEC (B5)	 CM/CP
7002	12.7	3630	45	14320	18	63 71 80 90 100 112 132 160 180	CM42 CM65 CP65
	15.3	3500	36	13080			
	17.3	3144	28.6	11480			
	20	2669	21	9720			
	24.1	3661	23.95	13080			
	27.2	3370	19.5	11480			
	31.6	2860	14.25	9720			
	38.1	2541	10.5	7860			
7003	53.6	4337	13.2	13080	14	63 71 80 90 100 112 132 160	CM42 CM65 CP65
	55.6	4313	12.65	13080			
	60.5	3856	10.4	11480			
	67.1	4442	10.8	13080			
	77.9	4584	9.6	13080			
	88	4045	7.5	11480			
	94.2	4677	8.1	13080			
	106.3	4302	6.6	11480			
	123.3	3659	4.84	9720			
	148.9	3012	3.3	7860			
7004	157.7	5541	5.94	14320	8	63 71 80 90 100 112 132	CM42 CM65 CP65
	174.1	5665	5.5	14320			
	190.1	5938	5.28	14320			
	210.3	5412	4.35	13080			
	229.6	5500	4.05	13080			
	248.4	5951	4.05	14320			
	274.8	5608	3.45	13080			
	300.1	6250	4.15	13080			
	331.2	5819	3.86	13080			
	361.7	5885	3.58	13080			
	393	4347	2.43	9720			
	453	6191	3	13080			
	511.5	5658	2.43	11480			
	557	4712	1.86	9720			
	594	5798	2.15	11480			
	656.7	5555	1.43	11480			
	717.7	5604	1.32	11480			
	832.6	4876	0.99	9720			
	921.5	5996	1.1	11480			
	1069	5565	0.88	9720			

n_{1max} = 2800 rpm

per ulteriori rapporti consultare l'ufficio tecnico

for information consult the technical office

DIMENSIONI · DIMENSIONS

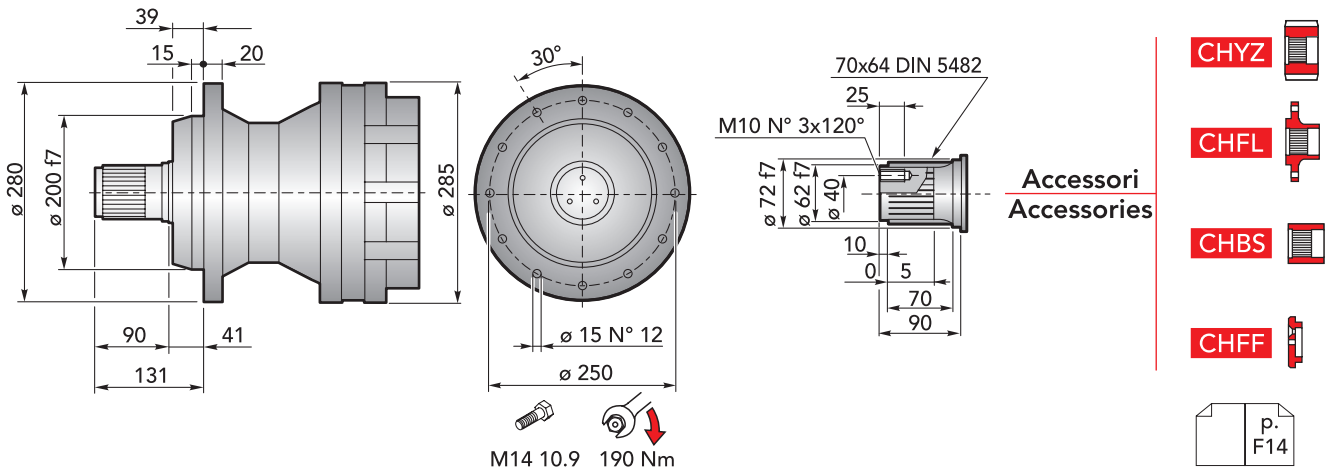

CHPL 7000 CPS - Flange motori IEC | IEC Motor flanges

CHPL	IEC 63			IEC 71			IEC 80			IEC 90			IEC 100		
	LP	P	ØD	LP	P	ØD	LP	P	ØD	LP	P	ØD	LP	P	ØD
7001	-	-	-	-	-	-	-	-	-	-	-	-	-	-	-
7002	345.5	-	-	345.5	-	-	365.5	-	-	365.5	-	-	375.5	-	-
7003	393.5	36	140	393.5	36	160	413.5	56	200	413.5	56	200	423.5	66	250
7004	441.5	-	-	441.5	-	-	461.5	-	-	461.5	-	-	471.5	-	-

CHPL	IEC 112			IEC 132			IEC 160			IEC 180			IEC 200		
	LP	P	ØD	LP	P	ØD	LP	P	ØD	LP	P	ØD	LP	P	ØD
7001	-	-	-	-	-	-	368	118	350	368	118	350	398	148	400
7002	375.5	-	-	409.5	-	-	448.5	-	-	448.5	139	350	-	-	-
7003	423.5	66	250	457.5	100	300	496.5	-	-	-	-	-	-	-	-
7004	471.5	-	-	505.5	-	-	-	-	-	-	-	-	-	-	-

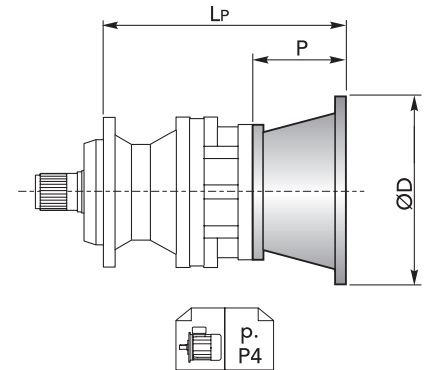

CHPL 7000 CPS - Alberi maschi entrata | Male input shafts

CHPL	CM42				CM65				CP65			
	LT	T	LE	ØE	LT	T	LE	ØE	LT	T	LE	ØE
7001	-	-	-	-	371.5	-	-	-	403	-	-	-
7002	402.5	-	-	-	444.5	121.5	105	65 h6	476	153	105	65 h6
7003	450.5	93	82	42 h6	-	-	-	-	-	-	-	-
7004	498.5	-	-	-	-	-	-	-	-	-	-	-

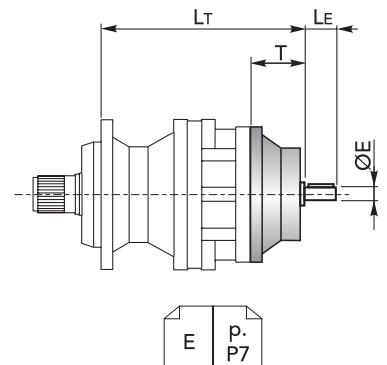



DIMENSIONI · DIMENSIONS

CHPL 7000 CPS - Riduttore a vite senza fine CHM in entrata | *CHM input worm gearboxes*

CHPL	CHM 50					CHM 63				
	Lv	I	H	M	N	Lv	I	H	M	N
7001	-					-				
7002	435					444.5				
7003	483	50	110	60	80	492.5	63	135	72	95
7004	531					540.5				

CHPL	CHM 75					CHM 90					CHM 110					
	Lv	I	H	M	N	Lv	I	H	M	N	Lv	I	H	M	N	
7001	-					-					388					
7002	423.5					433.5					461	110	237.5	127.5	160	
7003	471.5	75	161	86	112.5	481.5	90	193	103	129.5						
7004	519.5					529.5										

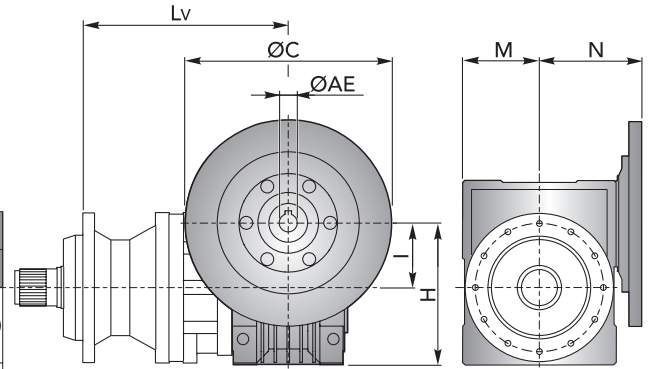

CHPL / CHPLB 7000 CPS

CHPLB 7000 CPS - Flange motori IEC | *IEC Motor flanges*

CHPLB	IEC 63				IEC 71				IEC 80				IEC 90			
	L	LP	P	ØD	L	LP	P	ØD	L	LP	P	ØD	L	LP	P	ØD
7002	338	276			338	276			338	296			338	296		
7003	384.5	196	36	140	384.5	196	36	160	384.5	216	56	200	384.5	216	56	200
7004	432.5				432.5				432.5				432.5			

CHPLB	IEC 100				IEC 112				IEC 132				IEC 160				IEC 180			
	L	LP	P	ØD	L	LP	P	ØD	L	LP	P	ØD	L	LP	P	ØD	L	LP	P	ØD
7002	338	306			338	306			338	340			338	379			338	379	139	350
7003	384.5	226	66	250	384.5	226	66	250	384.5	260	100	300	384.5	299	139	350				
7004	432.5				432.5				432.5				432.5							

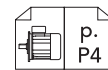
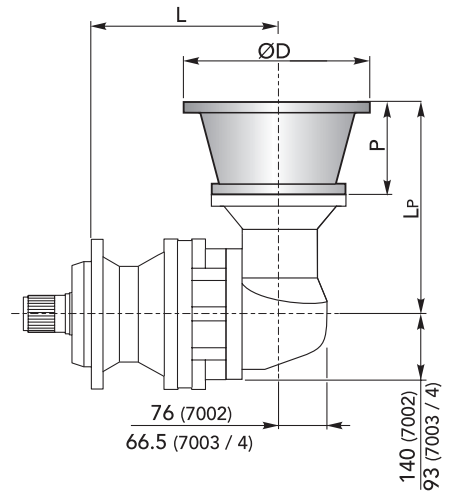

CHPLB 7000 CPS - Alberi maschi entrata | *Male input shafts*

CHPLB	CM42					CM65					CP65				
	L	LT	T	LE	ØE	L	LT	T	LE	ØE	L	LT	T	LE	ØE
7002	338	333				338	377.5				338	409			
7003	384.5	253	93	82	42 h6	384.5	297.5	121.5	105	65 h6	384.5	329	153	105	65 h6
7004	432.5					432.5					432.5				

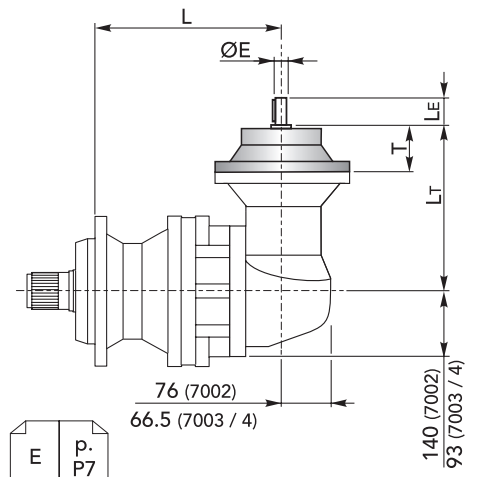

DIMENSIONI · DIMENSIONS

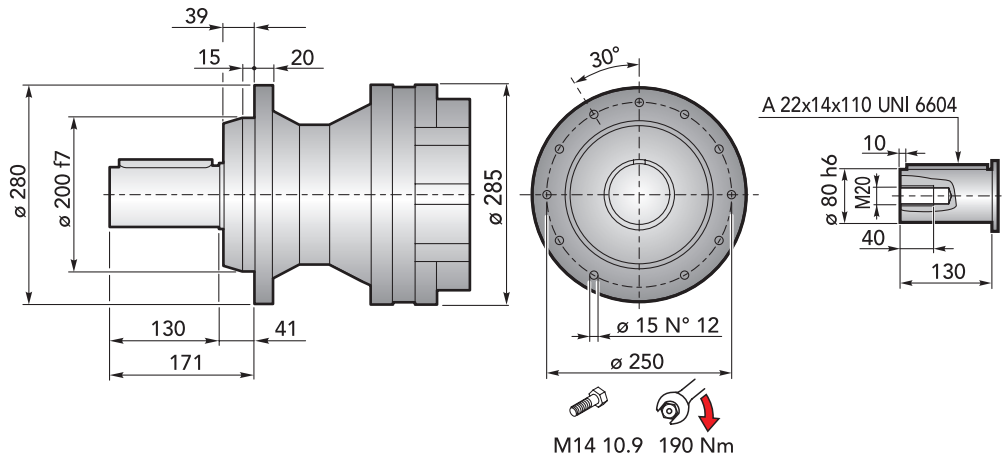

CHPL 7000 CPC - Flange motori IEC | IEC Motor flanges

CHPL	IEC 63			IEC 71			IEC 80			IEC 90			IEC 100		
	LP	P	ØD	LP	P	ØD	LP	P	ØD	LP	P	ØD	LP	P	ØD
7001	-			-			-			-			-		
7002	345.5			345.5			365.5			365.5			375.5		
7003	393.5	36	140	393.5	36	160	413.5	56	200	413.5	56	200	423.5	66	250
7004	441.5			441.5			461.5			461.5			471.5		

CHPL	IEC 112			IEC 132			IEC 160			IEC 180			IEC 200		
	LP	P	ØD	LP	P	ØD	LP	P	ØD	LP	P	ØD	LP	P	ØD
7001	-			-			368	118	350	368	118	350	398	148	400
7002	375.5			409.5			448.5			448.5	139	350	-		
7003	423.5	66	250	457.5	100	300	496.5			-			-		
7004	471.5			505.5			-			-			-		

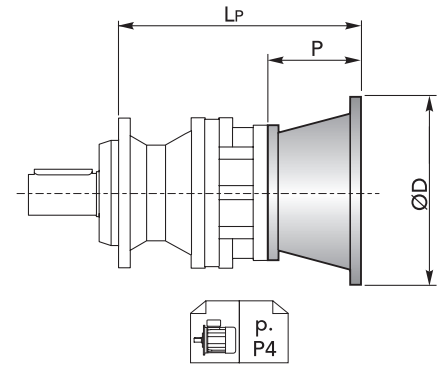

CHPL 7000 CPC - Alberi maschi entrata | Male input shafts

CHPL	CM42				CM65				CP65				
	LT	T	LE	ØE	LT	T	LE	ØE	LT	T	LE	ØE	
7001	-				371.5				403				
7002	402.5				444.5	121.5	105	65 h6	476	153	105	65 h6	
7003	450.5	93	82	42 h6	-			-					
7004	498.5				-			-					

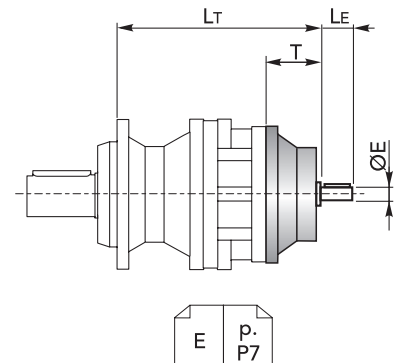



DIMENSIONI · DIMENSIONS

CHPL 7000 CPC - Riduttore a vite senza fine CHM in entrata | *CHM input worm gearboxes*

CHPL	CHM 50					CHM 63				
	Lv	I	H	M	N	Lv	I	H	M	N
7001	-					-				
7002	435					444.5				
7003	483	50	110	60	80	492.5	63	135	72	95
7004	531					540.5				

CHPL	CHM 75					CHM 90					CHM 110				
	Lv	I	H	M	N	Lv	I	H	M	N	Lv	I	H	M	N
7001	-					-					388				
7002	423.5					433.5					461	110	237.5	127.5	160
7003	471.5	75	161	86	112.5	481.5	90	193	103	129.5		-			
7004	519.5					529.5					-				

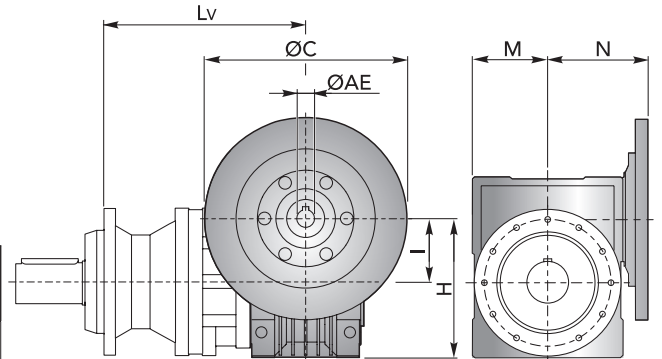

CHPL / CHPLB 7000 CPC

CHPLB 7000 CPC - Flange motori IEC | *IEC Motor flanges*

CHPLB	IEC 63				IEC 71				IEC 80				IEC 90			
	L	LP	P	ØD	L	LP	P	ØD	L	LP	P	ØD	L	LP	P	ØD
7002	338	276			338	276			338	296			338	296		
7003	384.5	196	36	140	384.5	196	36	160	384.5	216	56	200	384.5	216	56	200
7004	432.5				432.5				432.5				432.5			

CHPLB	IEC 100				IEC 112				IEC 132				IEC 160				IEC 180			
	L	LP	P	ØD	L	LP	P	ØD	L	LP	P	ØD	L	LP	P	ØD	L	LP	P	ØD
7002	338	306			338	306			338	340			338	379			338	379	139	350
7003	384.5	226	66	250	384.5	226	66	250	384.5	260	100	300	384.5	299	139	350	-			
7004	432.5				432.5				432.5				432.5				-			

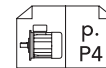
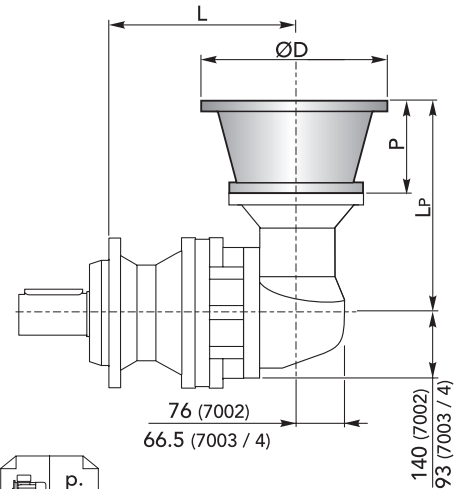

CHPLB 7000 CPC - Alberi maschi entrata | *Male input shafts*

CHPLB	CM42					CM65					CP65				
	L	Lt	T	Le	ØE	L	Lt	T	Le	ØE	L	Lt	T	Le	ØE
7002	338	333				338	377.5				338	409			
7003	384.5	253	93	82	42 h6	384.5	297.5	121.5	105	65 h6	384.5	329	153	105	65 h6
7004	432.5					432.5					432.5				

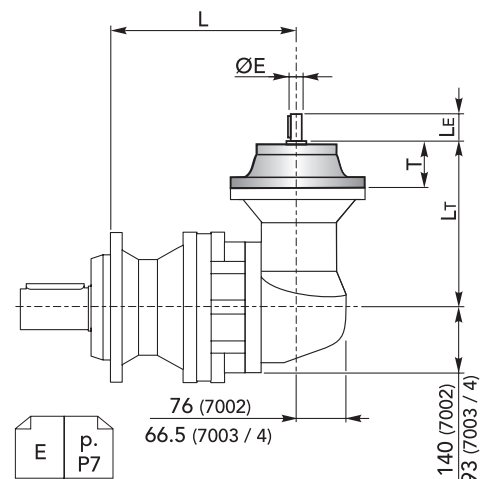

DIMENSIONI · DIMENSIONS

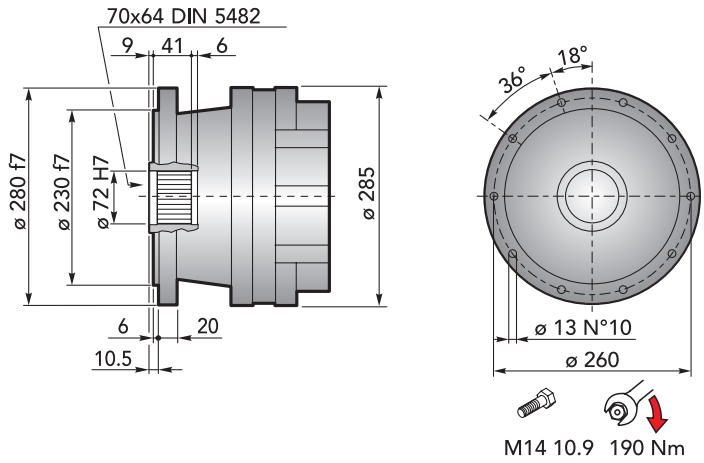

Accessori
Accessories

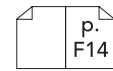

CHPL 7000 CF - Flange motori IEC | IEC Motor flanges

CHPL	IEC 63			IEC 71			IEC 80			IEC 90			IEC 100		
	LP	P	ØD	LP	P	ØD	LP	P	ØD	LP	P	ØD	LP	P	ØD
7001	-			-			-			-			-		
7002	292			292			312			312			322		
7003	340	36	140	340	36	160	360	56	200	360	56	200	370	66	250
7004	388			388			408			408			418		

CHPL	IEC 112			IEC 132			IEC 160			IEC 180			IEC 200		
	LP	P	ØD	LP	P	ØD	LP	P	ØD	LP	P	ØD	LP	P	ØD
7001	-			-			314.5	118	350	314.5	118	350	344.5	148	400
7002	322			356			395			395	139	350	-		
7003	370	66	250	404	100	300	443			-			-		
7004	418			452			-			-			-		

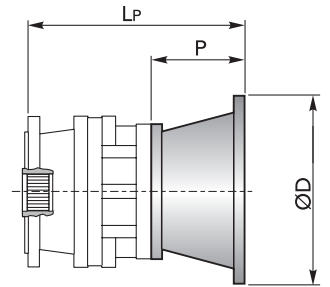

CHPL 7000 CF - Alberi maschi entrata | Male input shafts

CHPL	CM42				CM65				CP65				
	LT	T	LE	ØE	LT	T	LE	ØE	LT	T	LE	ØE	
7001	-				318				349.5				
7002	349				391	121.5	105	65 h6	422.5	153	105	65 h6	
7003	397	93	82	42 h6	-				-				
7004	445				-				-				

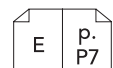
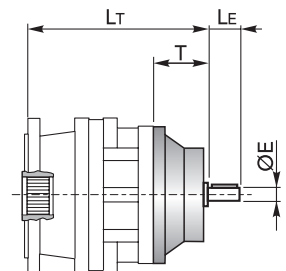



DIMENSIONI · DIMENSIONS

CHPL 7000 CF - Riduttore a vite senza fine CHM in entrata | *CHM input worm gearboxes*

CHPL	CHM 50					CHM 63				
	Lv	I	H	M	N	Lv	I	H	M	N
7001	-					-				
7002	338					391				
7003	429.5	50	110	60	80	439	63	135	72	95
7004	477.5					487				

CHPL	CHM 75					CHM 90					CHM 110					
	Lv	I	H	M	N	Lv	I	H	M	N	Lv	I	H	M	N	
7001	-					-					334.5					
7002	370					380					407.5	110	237.5	127.5	160	
7003	418	75	161	86	112.5	428	90	193	103	129.5						
7004	466					476										

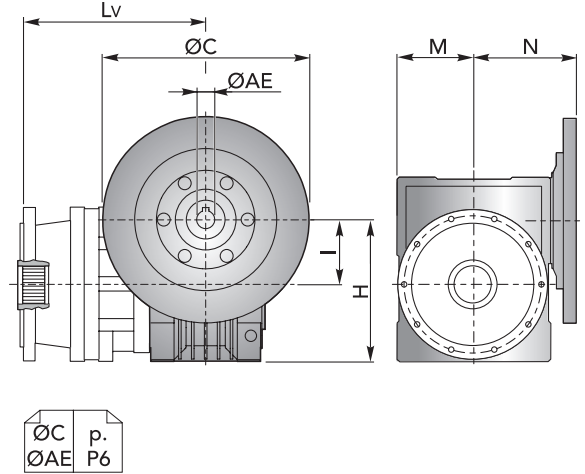

CHPL / CHPLB 7000 CF

CHPLB 7000 CF - Flange motori IEC | *IEC Motor flanges*

CHPLB	IEC 63				IEC 71				IEC 80				IEC 90			
	L	Lp	P	ØD	L	Lp	P	ØD	L	Lp	P	ØD	L	Lp	P	ØD
7002	284.5	276			284.5	276			284.5	296			284.5	296		
7003	331	196	36	140	331	196	36	160	331	216	56	200	331	216	56	200
7004	379				379				379				379			

CHPLB	IEC 100				IEC 112				IEC 132				IEC 160				IEC 180			
	L	Lp	P	ØD	L	Lp	P	ØD	L	Lp	P	ØD	L	Lp	P	ØD	L	Lp	P	ØD
7002	284.5	306			284.5	306			284.5	340			284.5	379			284.5	379	139	350
7003	331	226	66	250	331	226	66	250	331	260	100	300	331	299	139	350	-			
7004	379				379				379				379				-			

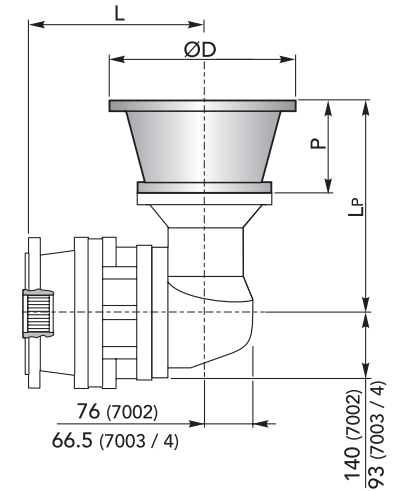

CHPLB 7000 CF - Alberi maschi entrata | *Male input shafts*

CHPLB	CM42					CM65					CP65				
	L	Lt	T	Le	ØE	L	Lt	T	Le	ØE	L	Lt	T	Le	ØE
7002	284.5	333				284.5	377.5				284.5	409			
7003	331	253	93	82	42 h6	331	297.5	121.5	105	65 h6	331	329	153	105	65 h6
7004	379					379					379				

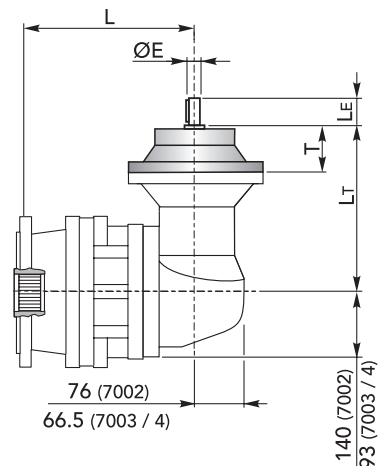

DIMENSIONI · DIMENSIONS

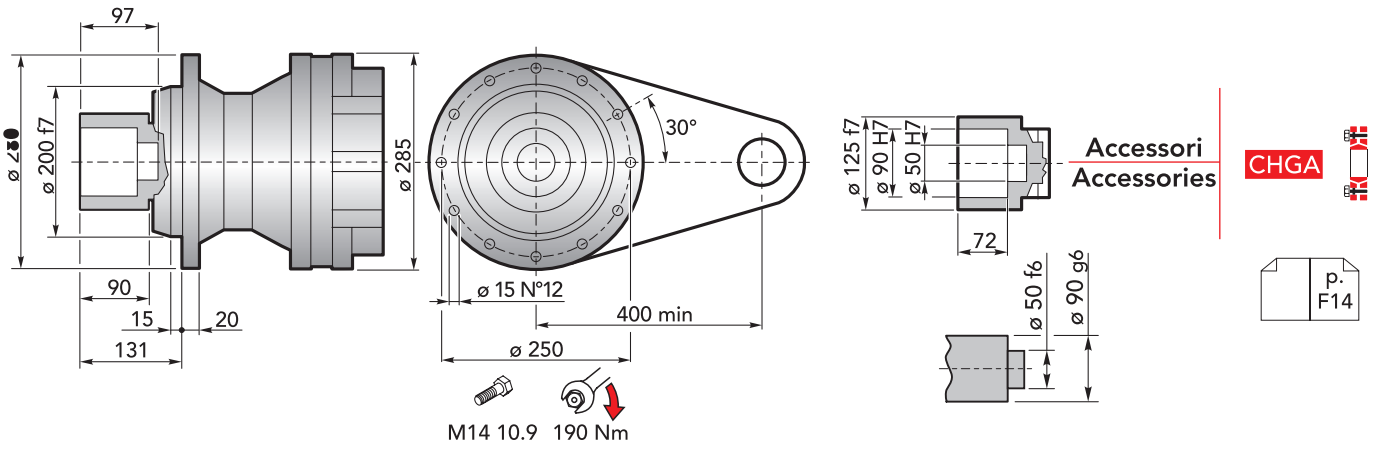

CHPL 7000 CFS - Flange motori IEC | IEC Motor flanges

CHPL	IEC 63			IEC 71			IEC 80			IEC 90			IEC 100		
	LP	P	ØD	LP	P	ØD	LP	P	ØD	LP	P	ØD	LP	P	ØD
7001	-			-			-			-			-		
7002	345.5			345.5			365.5			365.5			375.5		
7003	393.5	36	140	393.5	36	160	413.5	56	200	413.5	56	200	423.5	66	250
7004	441.5			441.5			461.5			461.5			471.5		

CHPL	IEC 112			IEC 132			IEC 160			IEC 180			IEC 200		
	LP	P	ØD	LP	P	ØD	LP	P	ØD	LP	P	ØD	LP	P	ØD
7001	-			-			368	118	350	368	118	350	398	148	400
7002	375.5			409.5			448.5			448.5	139	350	-		
7003	423.5	66	250	457.5	100	300	496.5			-			-		
7004	471.5			505.5			-			-			-		

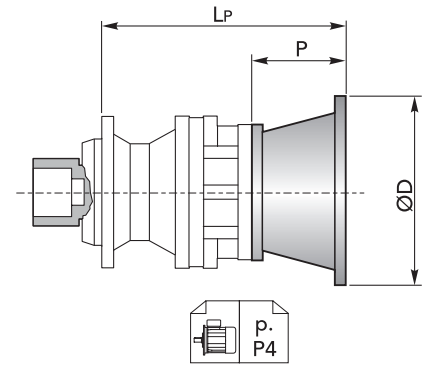

CHPL 7000 CFS - Alberi maschi entrata | Male input shafts

CHPL	CM42				CM65				CP65				
	LT	T	LE	ØE	LT	T	LE	ØE	LT	T	LE	ØE	
7001	-				371.5				403				
7002	402.5				444.5	121.5	105	65 h6	476	153	105	65 h6	
7003	450.5	93	82	42 h6	-			-					
7004	498.5				-			-					

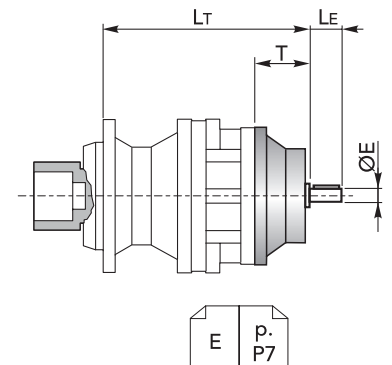



DIMENSIONI · DIMENSIONS

CHPL 7000 CFS - Riduttore a vite senza fine CHM in entrata | *CHM input worm gearboxes*

CHPL	CHM 50					CHM 63				
	Lv	I	H	M	N	Lv	I	H	M	N
7001	-					-				
7002	435					444.5				
7003	483	50	110	60	80	492.5	63	135	72	95
7004	531					540.5				

CHPL	CHM 75					CHM 90					CHM 110					
	Lv	I	H	M	N	Lv	I	H	M	N	Lv	I	H	M	N	
7001	-					-					388					
7002	423.5					433.5					461	110	237.5	127.5	160	
7003	471.5	75	161	86	112.5	481.5	90	193	103	129.5						
7004	519.5					529.5										

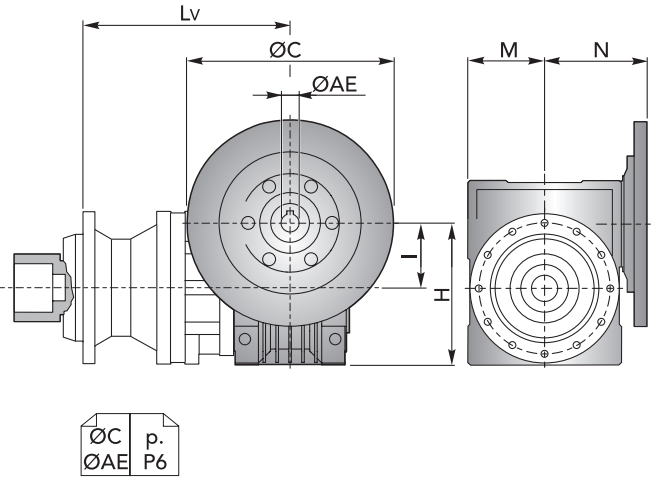

CHPL / CHPLB 7000 CFS

CHPLB 7000 CFS - Flange motori IEC | *IEC Motor flanges*

CHPLB	IEC 63				IEC 71				IEC 80				IEC 90			
	L	Lp	P	ØD	L	Lp	P	ØD	L	Lp	P	ØD	L	Lp	P	ØD
7002	338	276			338	276			338	296			338	296		
7003	384.5	196	36	140	384.5	196	36	160	384.5	216	56	200	384.5	216	56	200
7004	432.5				432.5				432.5				432.5			

CHPLB	IEC 100				IEC 112				IEC 132				IEC 160				IEC 180			
	L	Lp	P	ØD	L	Lp	P	ØD	L	Lp	P	ØD	L	Lp	P	ØD	L	Lp	P	ØD
7002	338	306			338	306			338	340			338	379			338	379	139	350
7003	384.5	226	66	250	384.5	226	66	250	384.5	260	100	300	384.5	299	139	350				
7004	432.5				432.5				432.5				432.5							

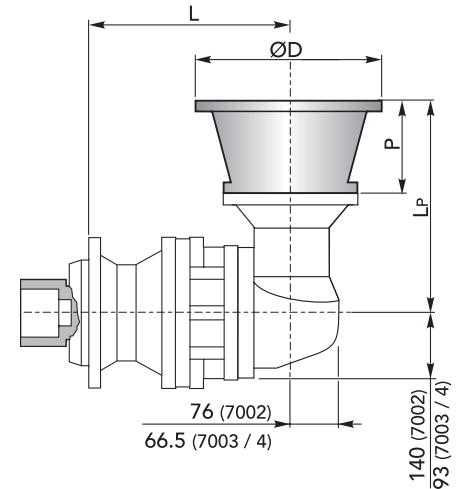

CHPLB 7000 CFS - Alberi maschi entrata | *Male input shafts*

CHPLB	CM42					CM65					CP65				
	L	Lt	T	Le	ØE	L	Lt	T	Le	ØE	L	Lt	T	Le	ØE
7002	338	333				338	377.5				338	409			
7003	384.5	253	93	82	42 h6	384.5	297.5	121.5	105	65 h6	384.5	329	153	105	65 h6
7004	432.5					432.5					432.5				

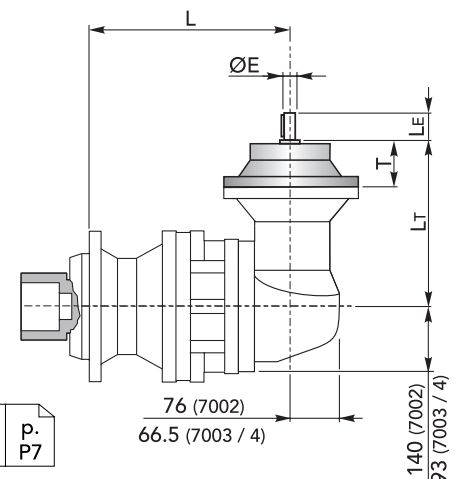
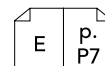
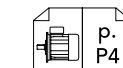

DIMENSIONI · DIMENSIONS

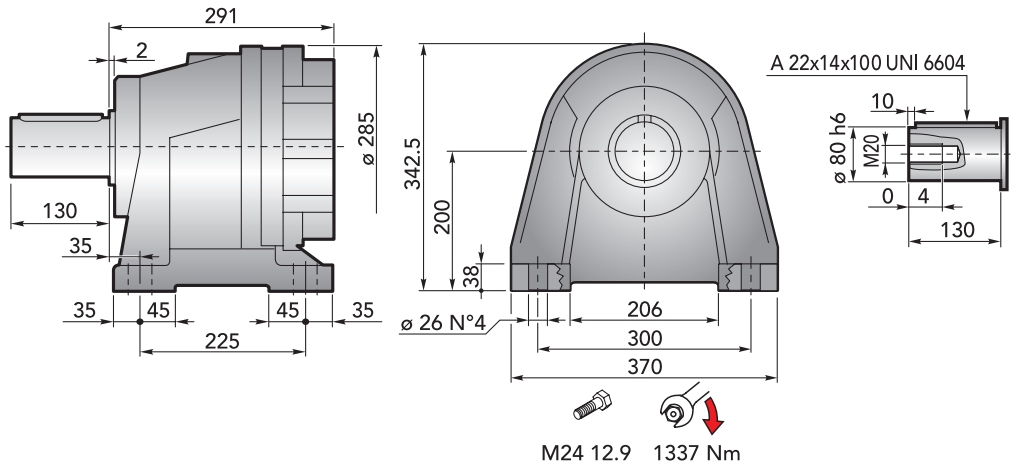

CHPL 7000 CCPC - Flange motori IEC | IEC Motor flanges

CHPL	IEC 63			IEC 71			IEC 80			IEC 90			IEC 100		
	LP	P	ØD	LP	P	ØD	LP	P	ØD	LP	P	ØD	LP	P	ØD
7001	-	-	-	-	-	-	-	-	-	-	-	-	-	-	-
7002	386.5	-	-	386.5	-	-	406.5	-	-	406.5	56	200	416.5	66	250
7003	434.5	36	140	434.5	36	160	454.5	56	200	454.5	56	200	464.5	66	250
7004	482.5	-	-	482.5	-	-	502.5	-	-	502.5	-	-	512.5	-	-

CHPL	IEC 112			IEC 132			IEC 160			IEC 180			IEC 200		
	LP	P	ØD	LP	P	ØD	LP	P	ØD	LP	P	ØD	LP	P	ØD
7001	-	-	-	-	-	-	409	118	350	409	118	350	439	148	400
7002	416.5	-	-	450.5	-	-	489.5	139	350	489.5	139	350	-	-	-
7003	464.5	66	250	498.5	100	300	537.5	-	-	-	-	-	-	-	-
7004	512.5	-	-	546.5	-	-	-	-	-	-	-	-	-	-	-

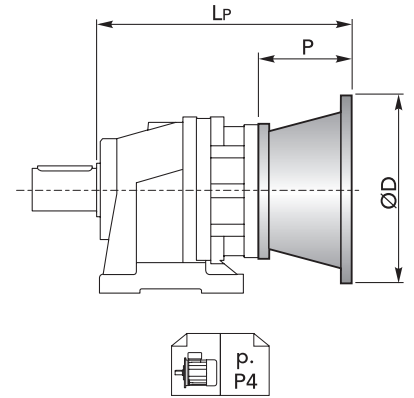

CHPL 7000 CCPC - Alberi maschi entrata | Male input shafts

CHPL	CM42				CM65				CP65			
	LT	T	LE	ØE	LT	T	LE	ØE	LT	T	LE	ØE
7001	-	-	-	-	412.5	121.5	105	65 h6	444	153	105	65 h6
7002	443.5	-	-	-	485.5	-	-	-	517	-	-	-
7003	491.5	93	82	42 h6	-	-	-	-	-	-	-	-
7004	539.5	-	-	-	-	-	-	-	-	-	-	-

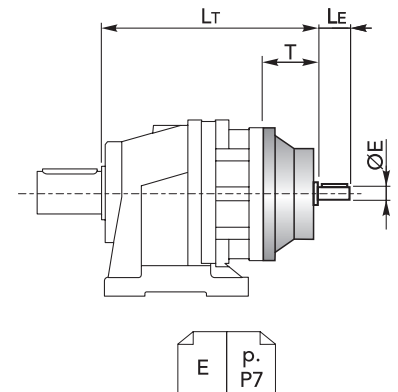



DIMENSIONI · DIMENSIONS

CHPL 7000 CCPC - Riduttore a vite senza fine CHM in entrata | *CHM input worm gearboxes*

CHPL	CHM 50					CHM 63				
	Lv	I	H	M	N	Lv	I	H	M	N
7001	-					-				
7002	476					485.5				
7003	524	50	110	60	80	533.5	63	135	72	95
7004	572					581.5				

CHPL	CHM 75					CHM 90					CHM 110				
	Lv	I	H	M	N	Lv	I	H	M	N	Lv	I	H	M	N
7001	-					-					429	110	237.5	127.5	160
7002	464.5					474.5					502				
7003	512.5	75	161	86	112.5	522.5	90	193	103	129.5					
7004	560.5					570.5									

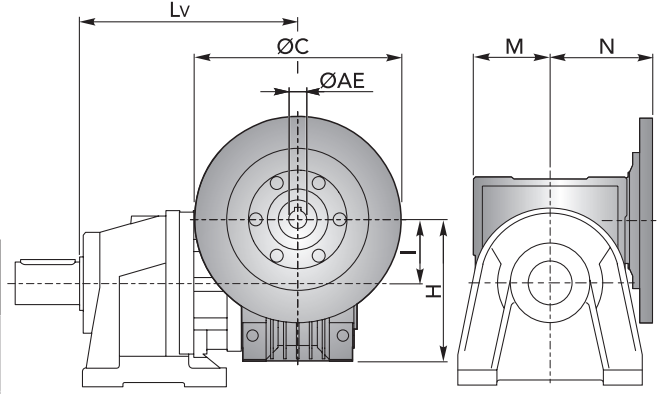

CHPL / CHPLB 7000 CCPC

CHPLB 7000 CCPC - Flange motori IEC | *IEC Motor flanges*

CHPLB	IEC 63				IEC 71				IEC 80				IEC 90			
	L	Lp	P	ØD	L	Lp	P	ØD	L	Lp	P	ØD	L	Lp	P	ØD
7002	379	276			379	276			379	296			379	296		
7003	425.5	196	36	140	425.5	196	36	160	425.5	216	56	200	425.5	216	56	200
7004	473.5				473.5				473.5				473.5			

CHPLB	IEC 100				IEC 112				IEC 132				IEC 160				IEC 180			
	L	Lp	P	ØD	L	Lp	P	ØD	L	Lp	P	ØD	L	Lp	P	ØD	L	Lp	P	ØD
7002	379	306			379	306			379	340			379	379	139	350	379	379	139	350
7003	425.5	226	66	250	425.5	226	66	250	425.5	260	100	300	425.5	299	139	350	-			
7004	473.5				473.5				473.5				473.5				-			

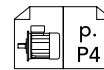
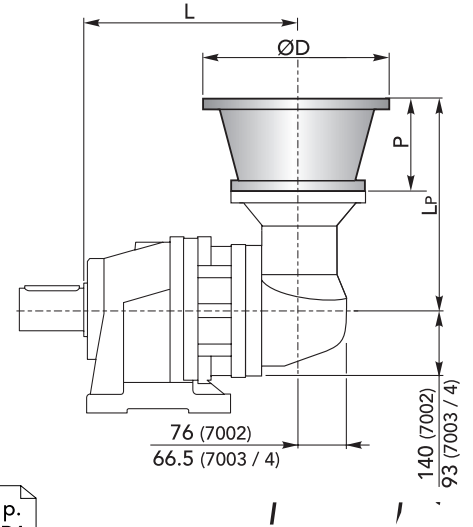

CHPLB 7000 CCPC - Alberi maschi entrata | *Male input shafts*

CHPLB	CM42					CM65					CP65				
	L	Lt	T	Le	ØE	L	Lt	T	Le	ØE	L	Lt	T	Le	ØE
7002	379	333				379	377.5				379	409			
7003	425.5	253	93	82	42 h6	425.5	297.5	121.5	105	65 h6	425.5	329	153	105	65 h6
7004	473.5					473.5					473.5				

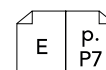
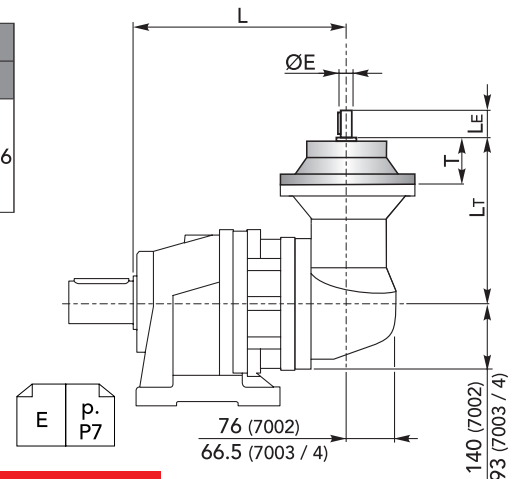

ACCESSORI · ACCESSORIES

CHYZ



Pignoni | Pinions

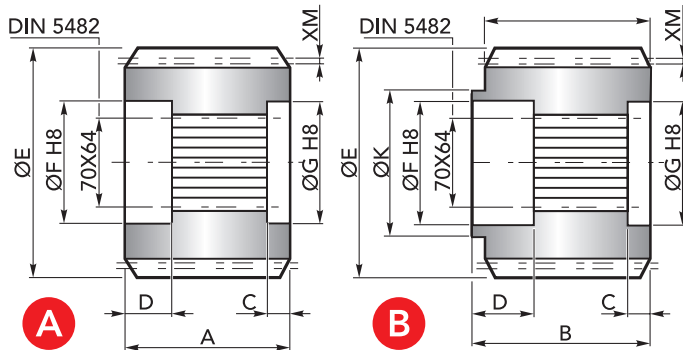

	Uscita / Output	M	Z	XM	A	B	C	D	E	F	G	K	Codice / Code
A	CPS	10	11	8.06	90	-	10	31	142.1	72	72	-	1071.267.042
	CPS	10	12	0	90	-	10	31	140	72	72	-	1071.166.042
	CPS	10	13	0	90	-	10	30	155	72	72	-	1071.201.042
B	CPS	10	11	8.06	90	99	18.5	31	142.1	72	72	84	1071.285.042

CHFF

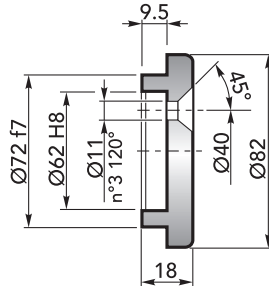

Fondello di arresto | Stop bottom plate

Codice / Code:
1075.012.000

CHBS

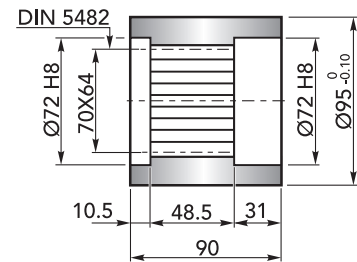

Boccola scanalata | Splined bushing

Codice / Code:
5171.102.076

CHKB

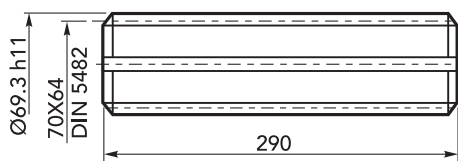

Barra scanalata | Splined rod

Codice / Code:
3071.405.042

CHGA

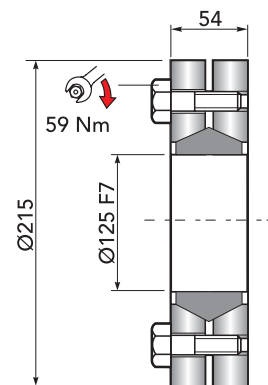

Giunto di attrito | Shrink disc

Codice / Code:
5109.125.000Coppia max: 13000 Nm⁽¹⁾
Max Torque: 13000 Nm⁽¹⁾

CHFL

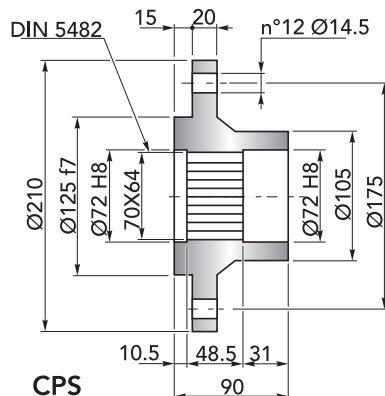

Flangia | Flange

Codice / Code:
5171.108.098

(1): Coppia max indicata è valida solo con calettatori forniti da Chiaravalli S.p.A.

(1): The maximum torque indicated is valid only with shrink discs supplied by Chiaravalli S.p.A.



CARICHI RADIALI (Fr) · RADIAL LOADS (Fr)

Nel diagramma seguente, sono indicati i carichi radiali F_r (N) applicabili sull'albero uscita in funzione della distanza di applicazione L rispetto alla battuta dell'albero.

The hereunder table shows the allowable radial loads F_r (N) on the output shaft with reference to the distance L .

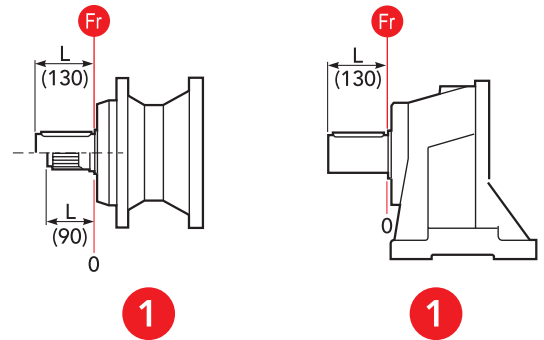
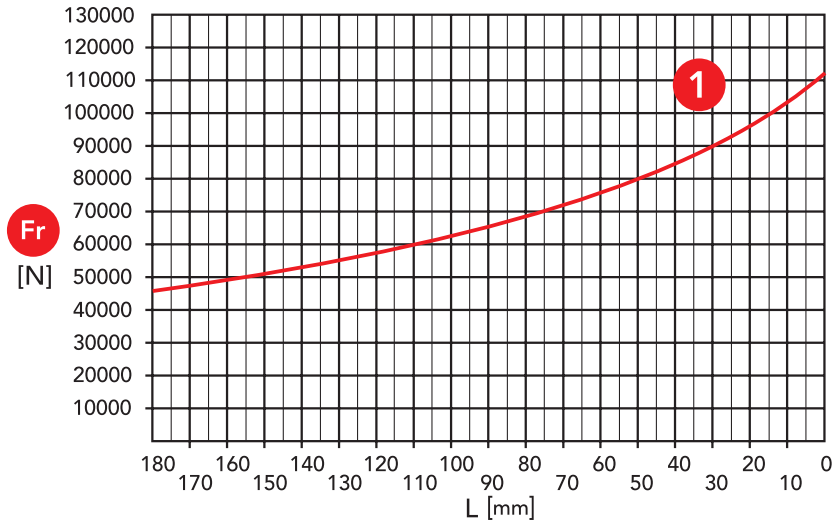

1 Uscita / Output: CPS, CPC, CCPC

CARICHI ASSIALI (Fa) · AXIAL LOADS (Fa)

Nella tabella seguente sono indicati i carichi assiali F_a (N) applicabili sull'albero di uscita in funzione della direzione di applicazione del carico e della versione.

The hereunder table shows the allowable axial loads F_a (N) on the output shaft with reference to the load direction and the output type.

	1	
Fa [N]	40000	←
	60000	→

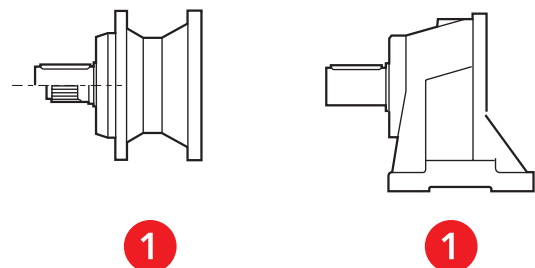

1 Uscita / Output: CPS, CPC, CCPC

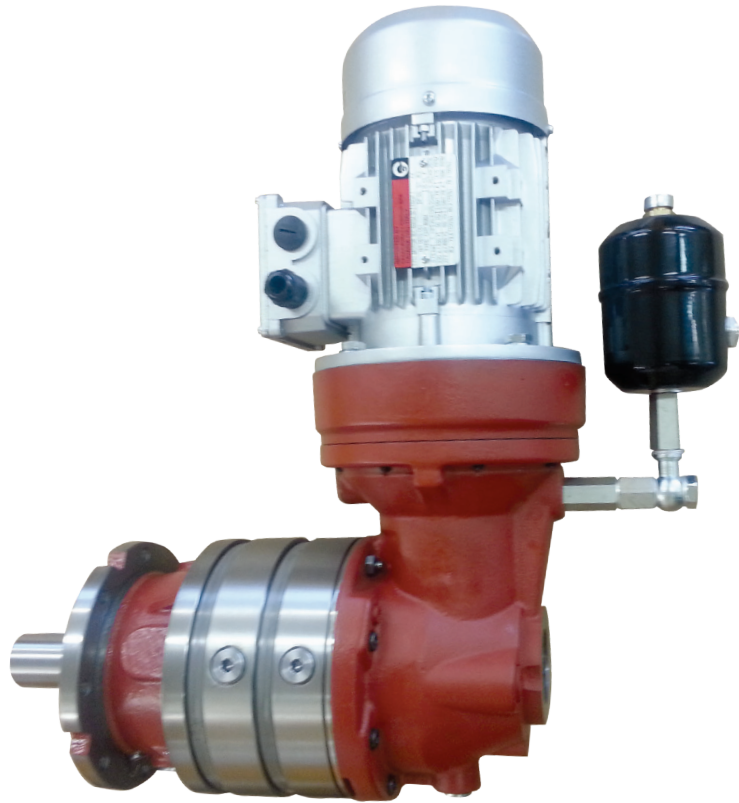



CHPL

	i	
10001	3.56 ÷ 8.67	1 reduction stage
10002	13.4 ÷ 48.9	2 reduction stages
10003	57.6 ÷ 330.3	3 reduction stages
10004	352.0 ÷ 2229.7	4 reduction stages

OUT

IN

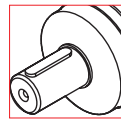

Ø90

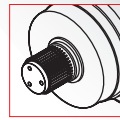

80x74
DIN 5482

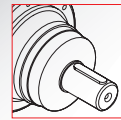

Ø42
Ø65

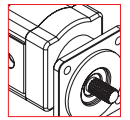

Hydraulic
Motor

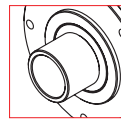

Ø100

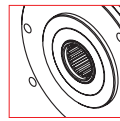

80x74
DIN 5482

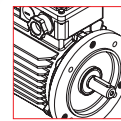

Electric
Motor

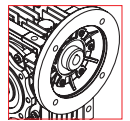

Worm
gearboxes

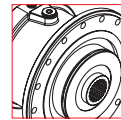

Brake

CHPLB

	i	
10002	12.3 ÷ 36.7	2 reduction stages
10003	46.4 ÷ 266.4	3 reduction stages
10004	140.1 ÷ 969.0	4 reduction stages

OUT

IN

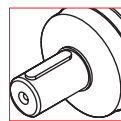

Ø90

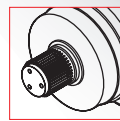

80x74
DIN 5482

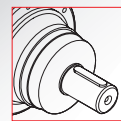

Ø42
Ø65

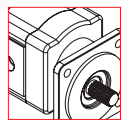

Hydraulic
Motor

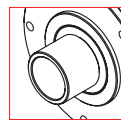

Ø100

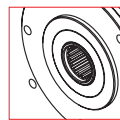

80x74
DIN 5482

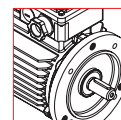

Electric
Motor

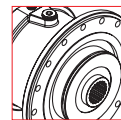

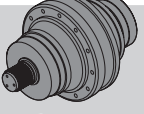
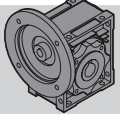
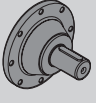

Brake

DATI TECNICI · TECHNICAL DATA

 CHPL	i	T _{2n} (n ₁ = 1400 rpm) 10.000h FS=1 [Nm]	P _{1n} (n ₁ = 1400 rpm) 10.000h FS=1 [kW]	T ₂ Max [Nm]	P _t 1400 rpm [kW]	IEC		 CHM	 CM/CP
						(B5)			
10001	3.56	5098	218	24900	40	160 200	180 225	CHM 110 CHM 130	CM65 CP65
	4.29	4448	158	21420					
	5.6	3595	98	16640					
	6.75	3000	68	12700					
	8.67	2140	38	9000					
10002	13.4	6385	75	24900	23	63 80 100 132 180	71 90 112 160	CHM 50 CHM 63 CHM 75 CHM 90 CHM 110 CHM 130	CM42 CM65 CP65
	16.2	5660	55	21420					
	18.4	6685	57	24900					
	22.1	5868	42	21420					
	25.7	6107	37.4	21420					
	28.9	4898	26.7	16640					
	33.6	5107	23.9	16640					
	40.5	4024	15.64	12700					
	48.9	4002	12.88	12700					
10003	57.6	8120	23	24900	15	63 80 100 132	71 90 112 160	CHM 50 CHM 63 CHM 75 CHM 90	CM42
	62.9	8513	22	24900					
	75.2	8482	18.4	24900					
	82.1	8797	17.48	24900					
	94.9	8028	13.8	21420					
	109.3	8040	12	21420					
	118.5	6319	8.7	16640					
	124	8208	10.8	21420					
	129.4	6426	8.1	16640					
	144	8475	9.6	21420					
	155.9	6595	6.9	16640					
	173.6	8619	8.1	21420					
	188.2	6853	5.94	16640					
	195.3	6848	5.72	16640					
	209.7	5373	4.18	12700					
	226.8	7036	5.06	16640					
	235.4	5398	3.74	12700					
	274.1	7022	4.18	16640					
330.3	5791	2.86	12700						
10004	352	10995	5.28	24900	11	63 80 100 132	71 90 112 160	CHM 50 CHM 63 CHM 75 CHM 90	CM42
	388.6	11126	4.84	24900					
	421.2	11510	4.62	24900					
	440.9	10329	3.96	21420					
	459.9	11970	4.4	24900					
	507.7	11893	3.96	24900					
	531.4	10374	3.3	21420					
	554.4	12266	3.74	24900					
	576.1	8247	2.42	16640					
	612	10356	2.86	21420					
	640.5	10836	2.86	21420					
	724.4	8485	1.98	16640					
	806.4	8395	1.76	16640					
	907.3	9446	1.65	16640					
	1008.9	11817	1.98	21420					
	1093.7	9251	1.43	16640					
	1270.1	9504	1.27	16640					
	1530.9	9962	1.1	16640					
	1849.8	10231	0.94	16640					
	2229.7	7980	0.61	12700					

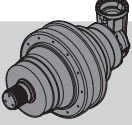

DATI TECNICI · TECHNICAL DATA

 CHPLB	i	T _{2n} (n ₁ = 1400 rpm) 10.000h FS=1 [Nm]	P _{1n} (n ₁ = 1400 rpm) 10.000h FS=1 [kW]	T ₂ Max [Nm]	P _t 1400 rpm [kW]	IEC (B5)		 CM/CP
10002	12.3	6329	81	24900	23	63	71	CM42 CM65 CP65
	14.8	5640	60	21420		80	90	
	19.3	4598	37.5	16640		100	112	
	23.3	3542	23.92	12700		132	160	
	30.5	4990	25.76	16640		180		
	36.7	3861	16.56	12700				
10003	46.4	7823	27.5	24900	15	63	71	CM42 CM65 CP65
	50.7	8206	26.4	24900		80	90	
	61.1	7004	18.7	21420		100	112	
	73.1	8379	18.7	24900		132	160	
	88.8	7785	14.3	21420				
	96.2	7785	13.2	21420				
	116.1	6264	8.8	16640				
	120.6	7984	10.8	21420				
	125.8	6479	8.4	16640				
	140	8239	9.6	21420				
	157.5	6566	6.8	16640				
	182.9	6728	6	16640				
	221	7045	5.2	16640				
	266.4	5226	3.2	12700				
10004	140.1	9614	11.6	24900	11	63	71	CM42 CM65 CP65
	168.9	9990	10	24900		80	90	
	184.4	8726	8	21420		100	112	
	203.5	8667	7.2	21420		132	160	
	230.9	10380	7.6	24900				
	265.9	9438	6	21420				
	278.4	10540	6.4	21420				
	301.8	9284	5.2	24900				
	320.6	9104	4.8	21420				
	350	7454	3.6	21420				
	379.5	7407	3.3	16640				
	418.9	7633	3.08	16640				
	457.4	7738	2.86	16640				
	510.4	7971	2.64	16640				
	551.9	8260	2.53	16640				
	665.3	8226	2.09	16640				
	803.9	8893	1.87	16640				
	969	6936	1.21	12700				

n_{1max} = 2800 rpm

per ulteriori rapporti consultare l'ufficio tecnico

for information consult the technical office

DIMENSIONI · DIMENSIONS

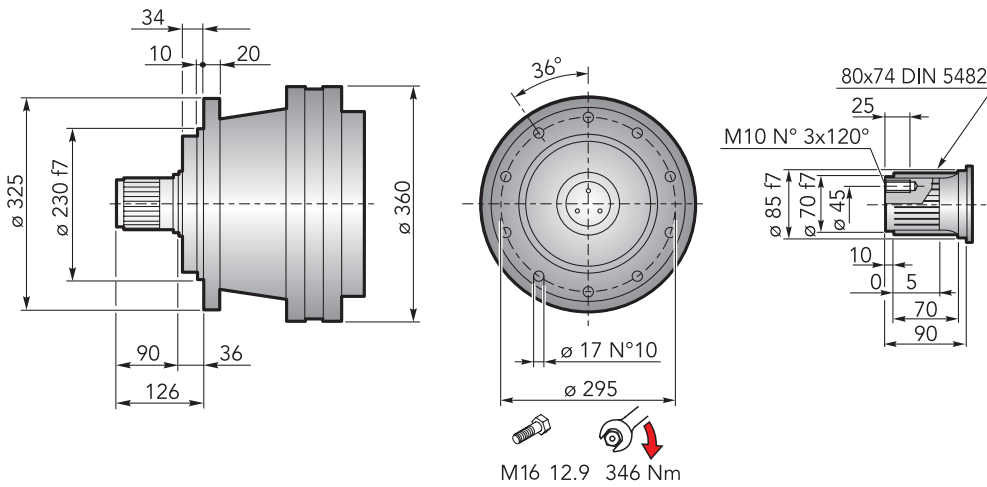

CHPL 10000 CMS - Flange motori IEC | IEC Motor flanges

CHPL	IEC 63			IEC 71			IEC 80			IEC 90			IEC 100		
	LP	P	ØD	LP	P	ØD	LP	P	ØD	LP	P	ØD	LP	P	ØD
10001	-			-			-			-			-		
10002	331.5			331.5			351.5			351.5			361.5		
10003	392.5	36	140	392.5	36	160	412.5	56	200	412.5	56	200	422.5	66	250
10004	440.5			440.5			460.5			460.5			470.5		

CHPL	IEC 112			IEC 132			IEC 160			IEC 180			IEC 200			IEC 225		
	LP	P	ØD	LP	P	ØD	LP	P	ØD	LP	P	ØD	LP	P	ØD	LP	P	ØD
10001	-			-			342	118	350	342	118	350	372	148	400	363	139	450
10002	361.5			395.5			434.5			434.5	139	350						
10003	422.5	66	250	456.5	100	300	495.5	139	350									
10004	470.5			504.5			543.5											

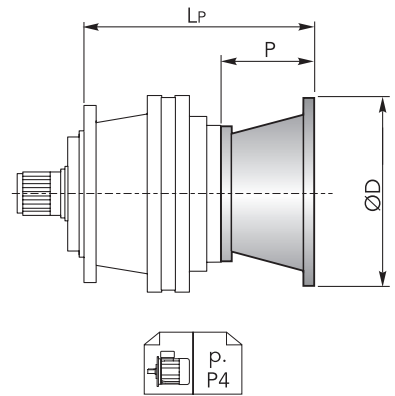

CHPL 10000 CMS - Alberi maschi entrata | Male input shafts

CHPL	CM42				CM65				CP65			
	LT	T	LE	ØE	LT	T	LE	ØE	LT	T	LE	ØE
10001	-				345.5	121.5	105	65 h6	377	153	105	65 h6
10002	388.5				430.5				462			
10003	449.5	93	82	42 h6								
10004	497.5											

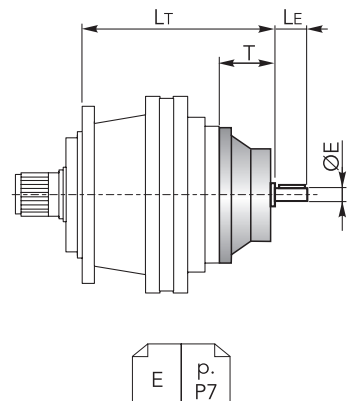



DIMENSIONI · DIMENSIONS

CHPL 10000 CMS - Riduttore a vite senza fine CHM in entrata | CHM input worm gearboxes

CHPL	CHM 50					CHM 63					CHM 75				
	Lv	I	H	M	N	Lv	I	H	M	N	Lv	I	H	M	N
10001	-					-					-				
10002	421					430.5					409.5				
10003	482	50	110	60	80	491.5	63	135	72	95	470.5	75	161	86	112.5
10004	530					539.5					518.5				

CHPL	CHM 90					CHM 110					CHM 130				
	Lv	I	H	M	N	Lv	I	H	M	N	Lv	I	H	M	N
10001	-					362	110	237.5	127.5	160	369	130	277.5	147.5	180
10002	419.5					447					454				
10003	480.5	90	193	103	129.5	-					-				
10004	528.5					-					-				

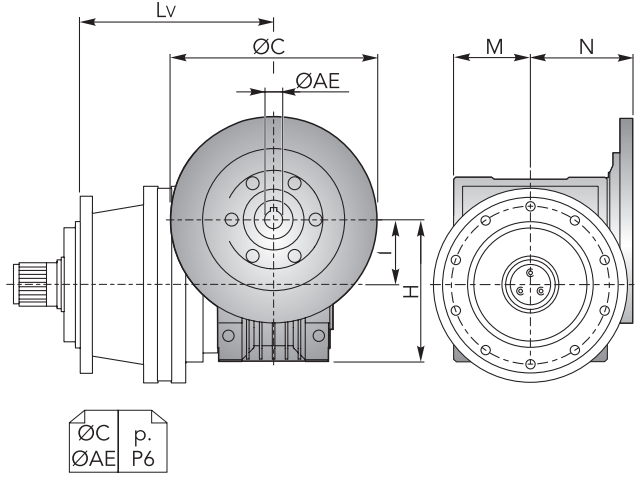

CHPL / CHPLB 10000 CMS

CHPLB 10000 CMS - Flange motori IEC | IEC Motor flanges

CHPLB	IEC 63				IEC 71				IEC 80				IEC 90			
	L	LP	P	ØD	L	LP	P	ØD	L	LP	P	ØD	L	LP	P	ØD
10002	312	276	36	140	312	276	36	160	312	296	56	200	312	296	56	200
10003	397				397				397				397			
10004	431.5	196			431.5	196			431.5	216			431.5	216		

CHPLB	IEC 100				IEC 112				IEC 132				IEC 160				IEC 180			
	L	LP	P	ØD	L	LP	P	ØD	L	LP	P	ØD	L	LP	P	ØD	L	LP	P	ØD
10002	312	306	66	250	312	306	66	250	312	340	100	300	312	379	139	350	312	379	139	350
10003	397				397				397				397				397			
10004	431.5	226			431.5	226			431.5	260			431.5	299						

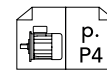
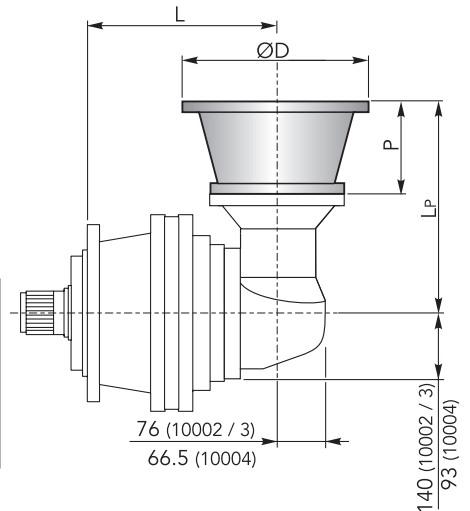

CHPLB 10000 CMS - Alberi maschi entrata | Male input shafts

CHPLB	CM42					CM65					CP65				
	L	Lt	T	Le	ØE	L	Lt	T	Le	ØE	L	Lt	T	Le	ØE
10002	312	333	93	82	42 h6	312	377.5	121.5	105	65 h6	312	409	153	105	65 h6
10003	397					397					397				
10004	431.5	253				431.5	297.5				431.5	329			

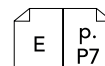
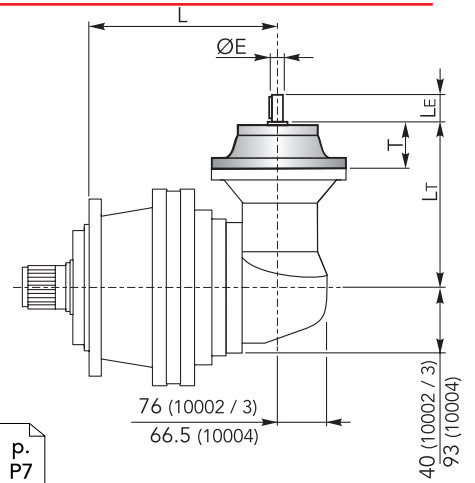

DIMENSIONI · DIMENSIONS

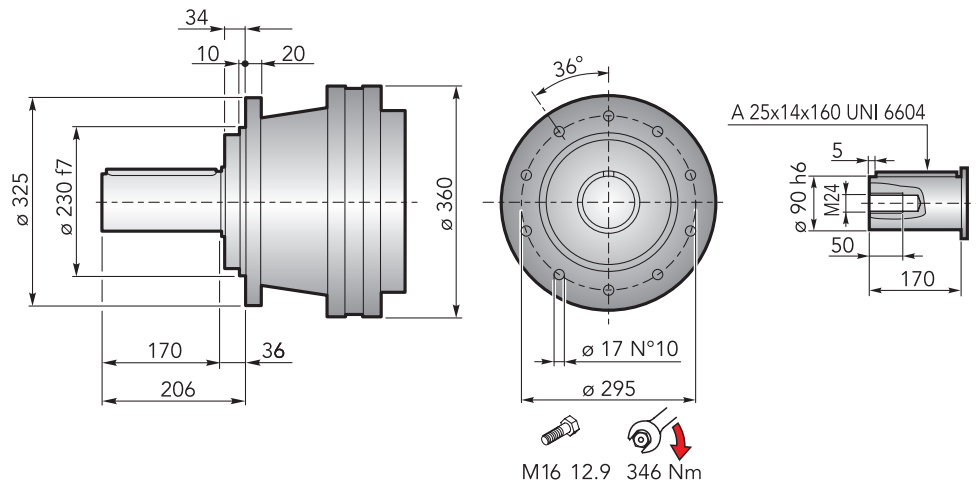

CHPL 10000 CMC - Flange motori IEC | IEC Motor flanges

CHPL	IEC 63			IEC 71			IEC 80			IEC 90			IEC 100		
	LP	P	ØD	LP	P	ØD	LP	P	ØD	LP	P	ØD	LP	P	ØD
10001	-			-			-			-			-		
10002	331.5			331.5			351.5			351.5			361.5		
10003	392.5	36	140	392.5	36	160	412.5	56	200	412.5	56	200	422.5	66	250
10004	440.5			440.5			460.5			460.5			470.5		

CHPL	IEC 112			IEC 132			IEC 160			IEC 180			IEC 200			IEC 225		
	LP	P	ØD	LP	P	ØD	LP	P	ØD	LP	P	ØD	LP	P	ØD	LP	P	ØD
10001	-			-			342	118	350	342	118	350	372	148	400	363	139	450
10002	361.5			395.5			434.5			434.5	139	350	-			-		
10003	422.5	66	250	456.5	100	300	495.5	139	350	-			-			-		
10004	470.5			504.5			543.5			-			-			-		

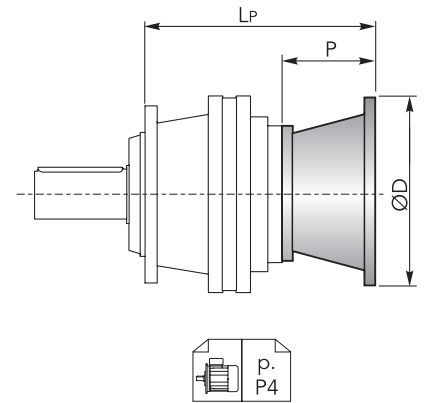

CHPL 10000 CMC - Alberi maschi entrata | Male input shafts

CHPL	CM42				CM65				CP65			
	LT	T	LE	ØE	LT	T	LE	ØE	LT	T	LE	ØE
10001	-				345.5	121.5	105	65 h6	377	153	105	65 h6
10002	388.5				430.5				462			
10003	449.5	93	82	42 h6	-				-			
10004	497.5				-				-			

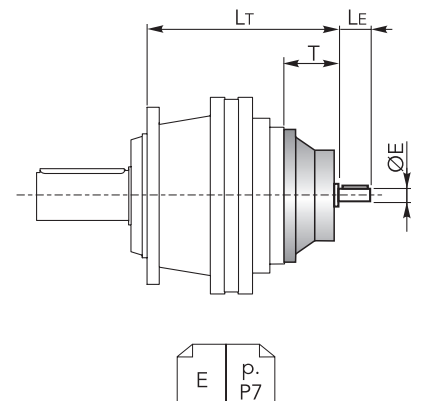



DIMENSIONI · DIMENSIONS

CHPL 10000 CMC - Riduttore a vite senza fine CHM in entrata | *CHM input worm gearboxes*

CHPL	CHM 50					CHM 63					CHM 75				
	Lv	I	H	M	N	Lv	I	H	M	N	Lv	I	H	M	N
10001	-					-					-				
10002	421					430.5					409.5				
10003	482	50	110	60	80	491.5	63	135	72	95	470.5	75	161	86	112.5
10004	530					539.5					518.5				

CHPL	CHM 90					CHM 110					CHM 130				
	Lv	I	H	M	N	Lv	I	H	M	N	Lv	I	H	M	N
10001	-					-					-				
10002	419.5					362	110	237.5	127.5	160	369	130	277.5	147.5	180
10003	480.5	90	193	103	129.5	-					-				
10004	528.5					-					-				

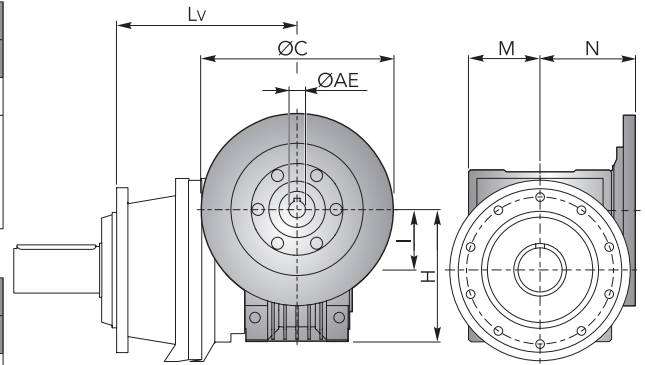

CHPL / CHPLB 10000 CMC

CHPLB 10000 CMC - Flange motori IEC | *IEC Motor flanges*

CHPLB	IEC 63				IEC 71				IEC 80				IEC 90			
	L	LP	P	ØD	L	LP	P	ØD	L	LP	P	ØD	L	LP	P	ØD
10002	312	276	36	140	312	276	36	160	312	296	56	200	312	296	56	200
10003	397				397				397				397			
10004	431.5	196			431.5	196			431.5	216			431.5	216		

CHPLB	IEC 100				IEC 112				IEC 132				IEC 160				IEC 180			
	L	LP	P	ØD	L	LP	P	ØD	L	LP	P	ØD	L	LP	P	ØD	L	LP	P	ØD
10002	312	306	66	250	312	306	66	250	312	340	100	300	312	379	139	350	312	379	139	350
10003	397				397				397				397				397			
10004	431.5	226			431.5	226			431.5	260			431.5	299						

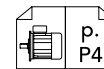
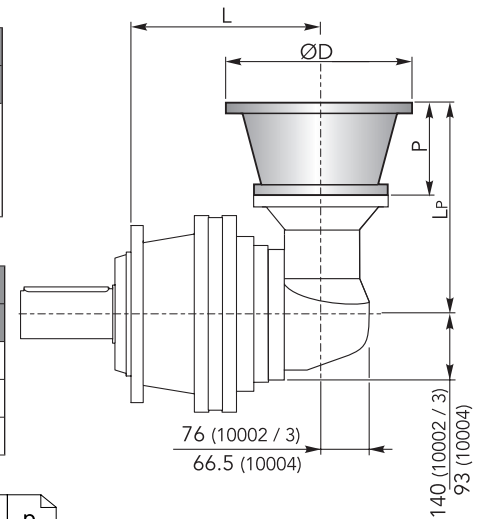

CHPLB 10000 CMC - Alberi maschi entrata | *Male input shafts*

CHPLB	CM42					CM65					CP65				
	L	Lt	T	Le	ØE	L	Lt	T	Le	ØE	L	Lt	T	Le	ØE
10002	312	333	93	82	42 h6	312	377.5	121.5	105	65 h6	312	409	153	105	65 h6
10003	397					397					397				
10004	431.5	253				431.5	297.5				431.5	329			

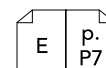
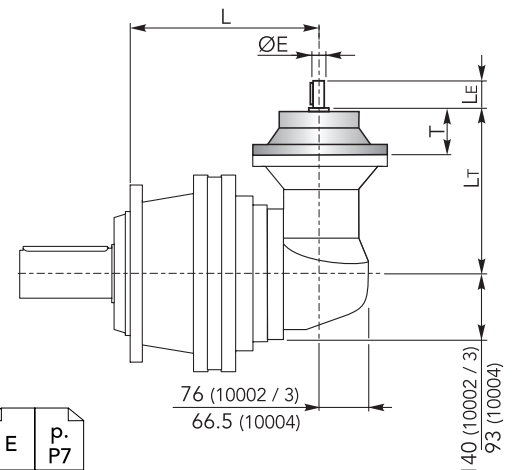



DIMENSIONI · DIMENSIONS

CHPL 10000 CF - Riduttore a vite senza fine CHM in entrata | *CHM input worm gearboxes*

CHPL	CHM 50					CHM 63					CHM 75				
	Lv	I	H	M	N	Lv	I	H	M	N	Lv	I	H	M	N
10001	-					-					-				
10002	308					317.5					296.5				
10003	369	50	110	60	80	378.5	63	135	72	95	357.5	75	161	86	112.5
10004	417					426.5					405.5				

CHPL	CHM 90					CHM 110					CHM 130				
	Lv	I	H	M	N	Lv	I	H	M	N	Lv	I	H	M	N
10001	-					-					-				
10002	306.5					334	110	237.5	127.5	160	256	130	277.5	147.5	180
10003	367.5	90	193	103	129.5										
10004	415.5														

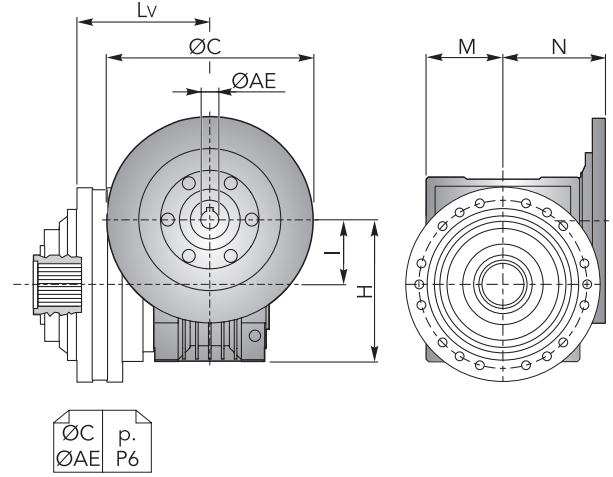

CHPL / CHPLB 10000 CF

CHPLB 10000 CF - Flange motori IEC | *IEC Motor flanges*

CHPLB	IEC 63				IEC 71				IEC 80				IEC 90			
	L	Lp	P	ØD	L	Lp	P	ØD	L	Lp	P	ØD	L	Lp	P	ØD
10002	199				199				199				199			
10003	284	276	36	140	284	276	36	160	284	296	56	200	284	296	56	200
10004	318.5	196			318.5	196			318.5	216			318.5	216		

CHPLB	IEC 100				IEC 112				IEC 132				IEC 160				IEC 180				
	L	Lp	P	ØD	L	Lp	P	ØD	L	Lp	P	ØD	L	Lp	P	ØD	L	Lp	P	ØD	
10002	199				199				199				199				199				350
10003	284	306	66	250	284	306	66	250	284	340	100	300	284	379	139	350					
10004	318.5	226			318.5	226			318.5	260			318.5	299							

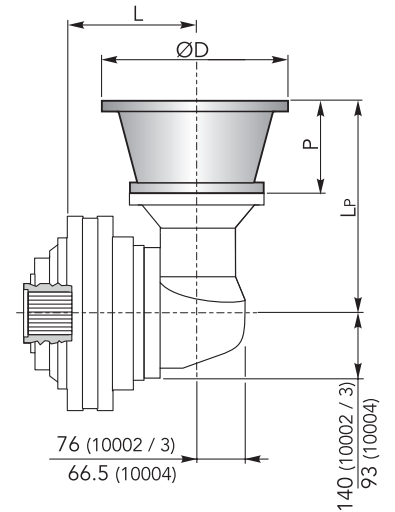

CHPLB 10000 CF - Alberi maschi entrata | *Male input shafts*

CHPLB	CM42					CM65					CP65				
	L	Lt	T	Le	ØE	L	Lt	T	Le	ØE	L	Lt	T	Le	ØE
10002	199					199					199				
10003	284	333	93	82	42 h6	284	377.5	121.5	105	65 h6	284	409	153	105	65 h6
10004	318.5	253				318.5	297.5				318.5	329			

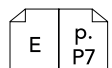
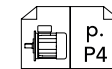
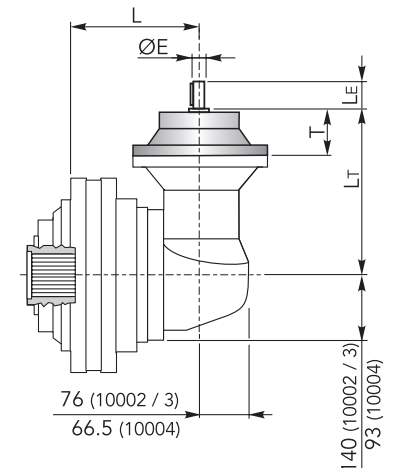

DIMENSIONI · DIMENSIONS

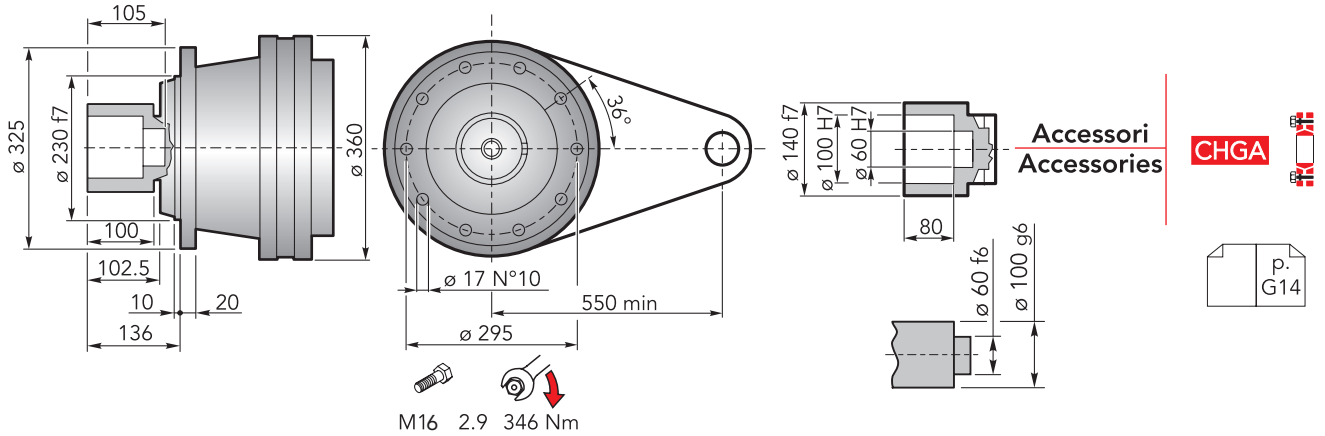

CHPL 10000 CFS - Flange motori IEC | IEC Motor flanges

CHPL	IEC 63			IEC 71			IEC 80			IEC 90			IEC 100		
	LP	P	ØD	LP	P	ØD	LP	P	ØD	LP	P	ØD	LP	P	ØD
10001	-			-			-			-			-		
10002	331.5			331.5			351.5			351.5			361.5		
10003	392.5	36	140	392.5	36	160	412.5	56	200	412.5	56	200	422.5	66	250
10004	440.5			440.5			460.5			460.5			470.5		

CHPL	IEC 112			IEC 132			IEC 160			IEC 180			IEC 200			IEC 225		
	LP	P	ØD	LP	P	ØD	LP	P	ØD	LP	P	ØD	LP	P	ØD	LP	P	ØD
10001	-			-			342	118	350	342	118	350	372	148	400	363	139	450
10002	361.5			395.5			434.5			434.5	139	350						
10003	422.5	66	250	456.5	100	300	495.5	139	350									
10004	470.5			504.5			543.5											

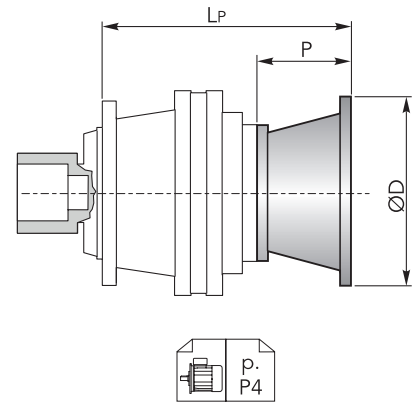

CHPL 10000 CFS - Alberi maschi entrata | Male input shafts

CHPL	CM42				CM65				CP65			
	LT	T	LE	ØE	LT	T	LE	ØE	LT	T	LE	ØE
10001	-				345.5	121.5	105	65 h6	377	153	105	65 h6
10002	388.5				430.5				462			
10003	449.5	93	82	42 h6								
10004	497.5											

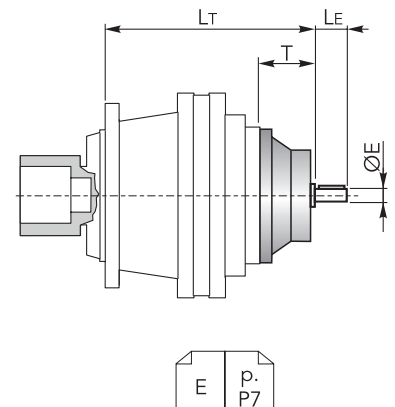



DIMENSIONI · DIMENSIONS

CHPL 10000 CFS - Riduttore a vite senza fine CHM in entrata | CHM input worm gearboxes

CHPL	CHM 50					CHM 63					CHM 75				
	Lv	I	H	M	N	Lv	I	H	M	N	Lv	I	H	M	N
10001	-					-					-				
10002	421					430.5					409.5				
10003	482	50	110	60	80	491.5	63	135	72	95	470.5	75	161	86	112.5
10004	530					539.5					518.5				

CHPL	CHM 90					CHM 110					CHM 130				
	Lv	I	H	M	N	Lv	I	H	M	N	Lv	I	H	M	N
10001	-					362	110	237.5	127.5	160	369	130	277.5	147.5	180
10002	419.5					447					454				
10003	480.5	90	193	103	129.5	-					-				
10004	528.5					-					-				

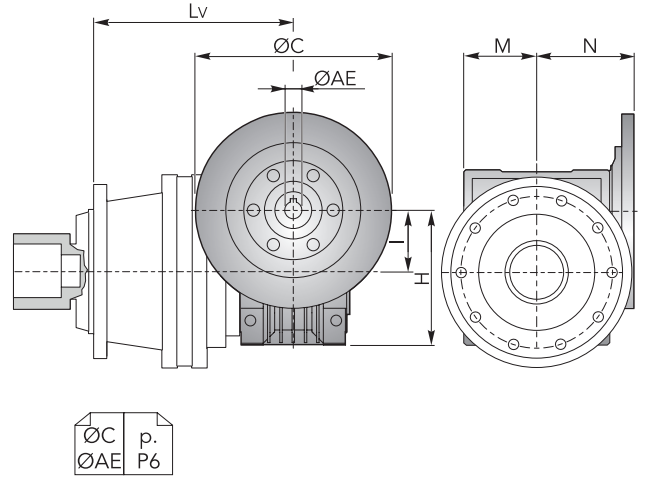

CHPL / CHPLB 10000 CFS

CHPLB 10000 CFS - Flange motori IEC | IEC Motor flanges

CHPLB	IEC 63				IEC 71				IEC 80				IEC 90			
	L	LP	P	ØD	L	LP	P	ØD	L	LP	P	ØD	L	LP	P	ØD
10002	312				312	276	36	140	312	296	56	200	312	296	56	200
10003	397	276	36	140	397	276	36	160	397	296	56	200	397	296	56	200
10004	431.5	196			431.5	196			431.5	216			431.5	216		

CHPLB	IEC 100				IEC 112				IEC 132				IEC 160				IEC 180			
	L	LP	P	ØD	L	LP	P	ØD	L	LP	P	ØD	L	LP	P	ØD	L	LP	P	ØD
10002	312				312	306			312	340			312	379			312	379	139	350
10003	397	306	66	250	397	306	66	250	397	340	100	300	397	379	139	350	-			
10004	431.5	226			431.5	226			431.5	260			431.5	299			-			

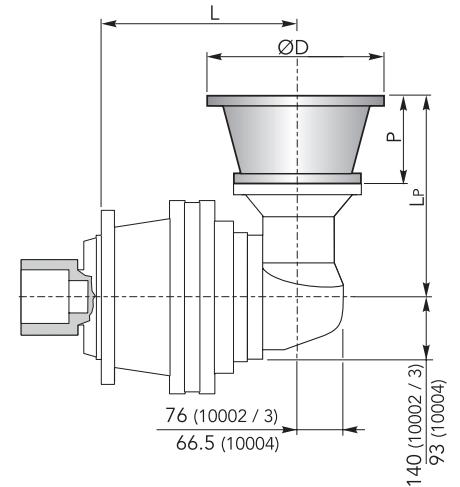

CHPLB 10000 CFS - Alberi maschi entrata | Male input shafts

CHPLB	CM42					CM65					CP65				
	L	Lt	T	Le	ØE	L	Lt	T	Le	ØE	L	Lt	T	Le	ØE
10002	312					312	377.5				312	409			
10003	397	333	93	82	42 h6	397	377.5	121.5	105	65 h6	397	409	153	105	65 h6
10004	431.5	253				431.5	297.5				431.5	329			

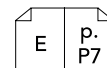
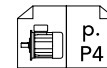
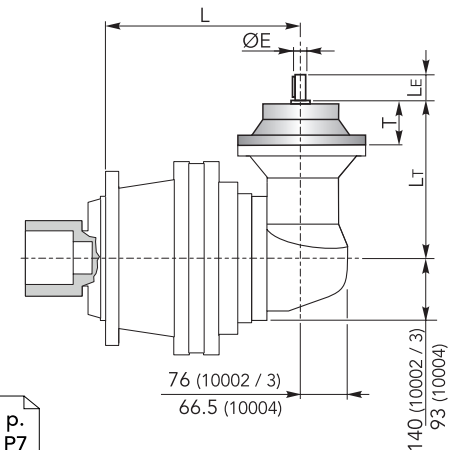

DIMENSIONI · DIMENSIONS

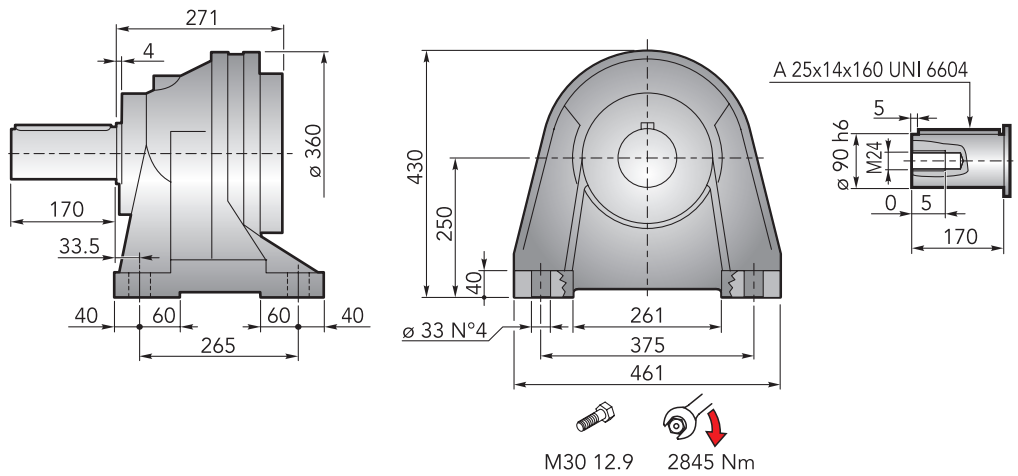

CHPL 10000 CCPC - Flange motori IEC | IEC Motor flanges

CHPL	IEC 63			IEC 71			IEC 80			IEC 90			IEC 100		
	LP	P	ØD	LP	P	ØD	LP	P	ØD	LP	P	ØD	LP	P	ØD
10001	-	-	-	-	-	-	-	-	-	-	-	-	-	-	-
10002	378.5	-	-	378.5	-	-	398.5	-	-	398.5	-	-	408.5	-	-
10003	439.5	36	140	439.5	36	160	459.5	56	200	459.5	56	200	469.5	66	250
10004	487.5	-	-	487.5	-	-	507.5	-	-	507.5	-	-	517.5	-	-

CHPL	IEC 112			IEC 132			IEC 160			IEC 180			IEC 200			IEC 225		
	LP	P	ØD	LP	P	ØD	LP	P	ØD	LP	P	ØD	LP	P	ØD	LP	P	ØD
10001	-	-	-	-	-	-	389	118	350	389	118	350	419	148	400	410	139	450
10002	408.5	-	-	442.5	-	-	481.5	-	-	481.5	139	350	-	-	-	-	-	-
10003	469.5	66	250	503.5	100	300	542.5	139	350	-	-	-	-	-	-	-	-	-
10004	517.5	-	-	551.5	-	-	590.5	-	-	-	-	-	-	-	-	-	-	-

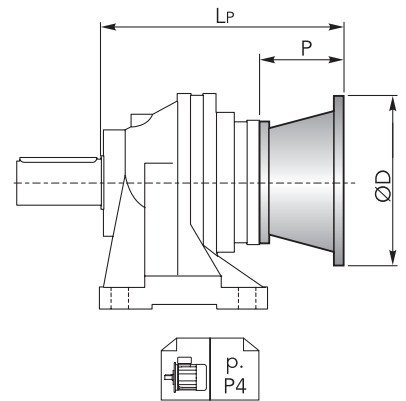

CHPL 10000 CCPC - Alberi maschi entrata | Male input shafts

CHPL	CM42				CM65				CP65			
	LT	T	LE	ØE	LT	T	LE	ØE	LT	T	LE	ØE
10001	-	-	-	-	392.5	121.5	105	65 h6	424	153	105	65 h6
10002	435.5	-	-	-	477.5	-	-	-	509	-	-	-
10003	496.5	93	82	42 h6	-	-	-	-	-	-	-	-
10004	544.5	-	-	-	-	-	-	-	-	-	-	-

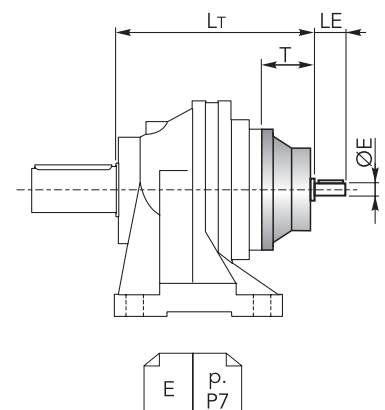



DIMENSIONI · DIMENSIONS

CHPL 10000 CCPC - Riduttore a vite senza fine CHM in entrata | CHM input worm gearboxes

CHPL	CHM 50					CHM 63					CHM 75				
	Lv	I	H	M	N	Lv	I	H	M	N	Lv	I	H	M	N
10001	-					-					-				
10002	468					477.5					456.5				
10003	529	50	110	60	80	538.5	63	135	72	95	517.5	75	161	86	112.5
10004	577					586.5					565.5				

CHPL	CHM 90					CHM 110					CHM 130				
	Lv	I	H	M	N	Lv	I	H	M	N	Lv	I	H	M	N
10001	-					-					-				
10002	466.5					494	110	237.5	127.5	160	416	130	277.5	147.5	180
10003	527.5	90	193	103	129.5	-					-				
10004	575.5					-					-				

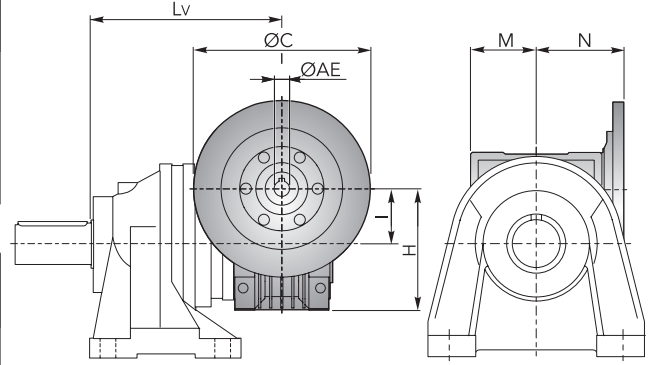

CHPL / CHPLB 10000 CCPC

CHPLB 10000 CCPC - Flange motori IEC | IEC Motor flanges

CHPLB	IEC 63				IEC 71				IEC 80				IEC 90			
	L	Lp	P	ØD	L	Lp	P	ØD	L	Lp	P	ØD	L	Lp	P	ØD
10002	359				359				359				359			
10003	444	276	36	140	444	276	36	160	444	296	56	200	444	296	56	200
10004	478.5	196			478.5	196			478.5	216			478.5	216		

CHPLB	IEC 100				IEC 112				IEC 132				IEC 160				IEC 180				
	L	Lp	P	ØD	L	Lp	P	ØD	L	Lp	P	ØD	L	Lp	P	ØD	L	Lp	P	ØD	
10002	359				359				359				359				359				350
10003	444	306	66	250	444	306	66	250	444	340	100	300	444	379	139	350	-				
10004	478.5	226			478.5	226			478.5	260			478.5	299			-				

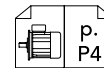
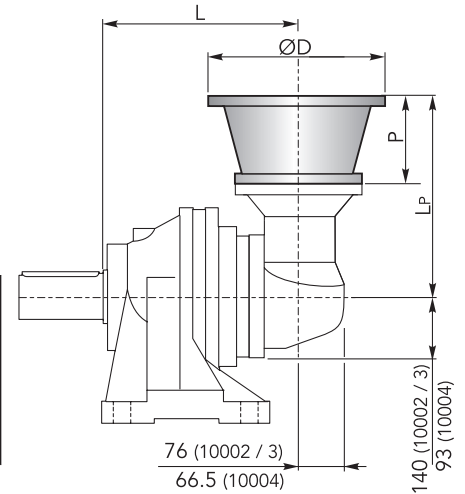

CHPLB 10000 CCPC - Alberi maschi entrata | Male input shafts

CHPLB	CM42					CM65					CP65				
	L	Lt	T	Le	ØE	L	Lt	T	Le	ØE	L	Lt	T	Le	ØE
10002	359					359					359				
10003	444	333	93	82	42 h6	444	377.5	121.5	105	65 h6	444	409	153	105	65 h6
10004	478.5	253				478.5	297.5				478.5	329			

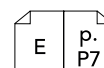
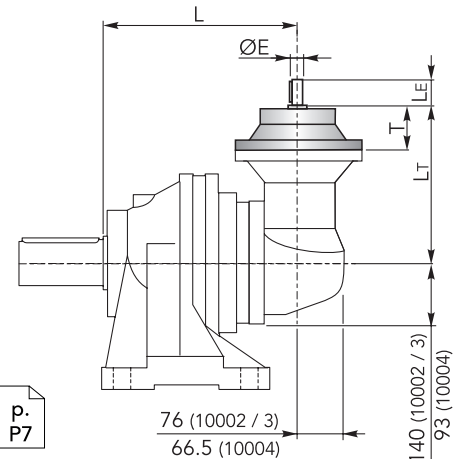

ACCESSORI · ACCESSORIES

CHYZ



Pignoni | Pinions

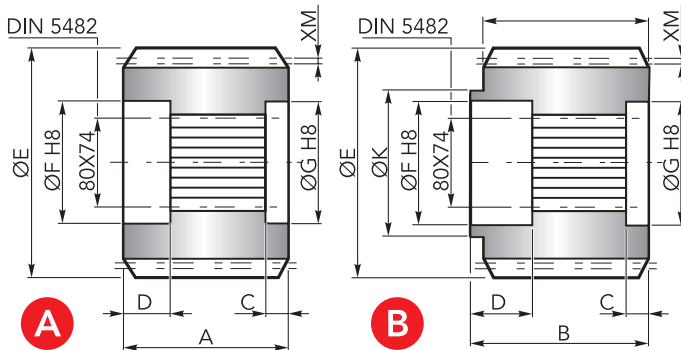

	Uscita / Output	M	Z	XM	A	B	C	D	E	F	G	K	Codice / Code
A	CMC	10	12	0	90	-	10	31	140	85	80	-	1071.236.042
	CMC	10	14	0	90	-	10	31	160	85	80	-	1071.238.042
B	CMC	12	14	3	90	115	25	31	194.5	85	80	130	1071.286.042

CHFF

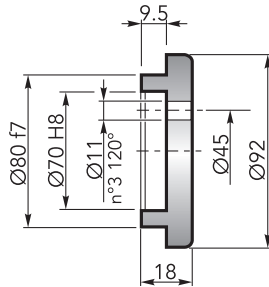

Fondello di arresto | Stop bottom plate

Codice / Code:
1075.030.000

CHBS

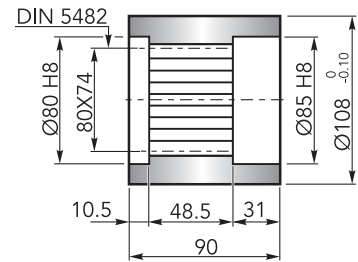

Boccola scanalata | Splined bushing

Codice / Code:
6171.103.076

CHKB

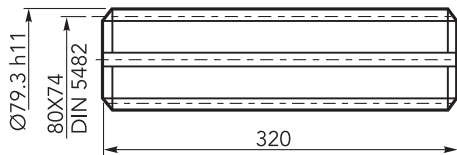

Barra scanalata | Splined rod

Codice / Code:
3071.406.042

CHGA

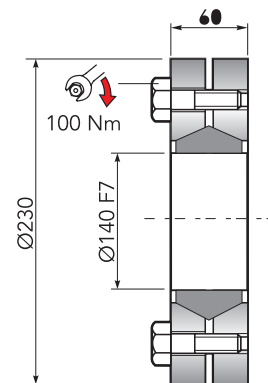

Giunto di attrito | Shrink disc

Codice / Code:
5109.140.000Coppia max: 17600 Nm(1)
Max Torque: 17600 Nm(1)Codice / Code:
5109.140.000

CHFL

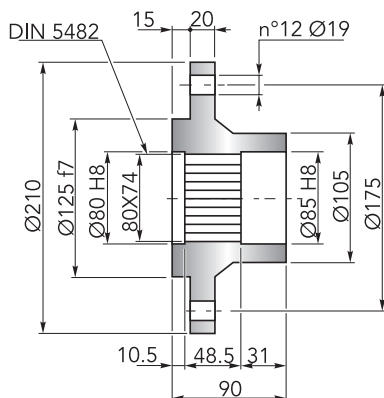

Flangia | Flange

Codice / Code:
6171.105.098

(1): Coppia max indicata è valida solo con calettatori forniti da Chiaravalli S.p.A.

(1): The maximum torque indicated is valid only with shrink discs supplied by Chiaravalli S.p.A.



CARICHI RADIALI (Fr) · RADIAL LOADS (Fr)

Nel diagramma seguente, sono indicati i carichi radiali Fr (N) applicabili sull'albero uscita in funzione della distanza di applicazione L rispetto alla battuta dell'albero.

The hereunder table shows the allowable radial loads Fr (N) on the output shaft with reference to the distance L.

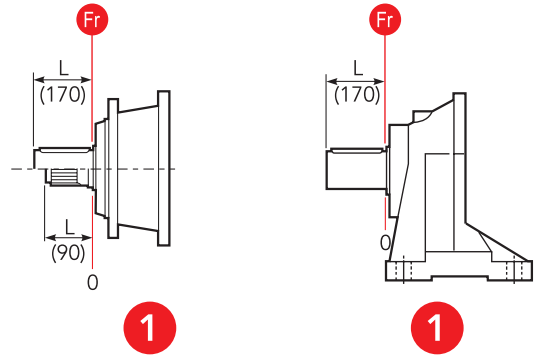
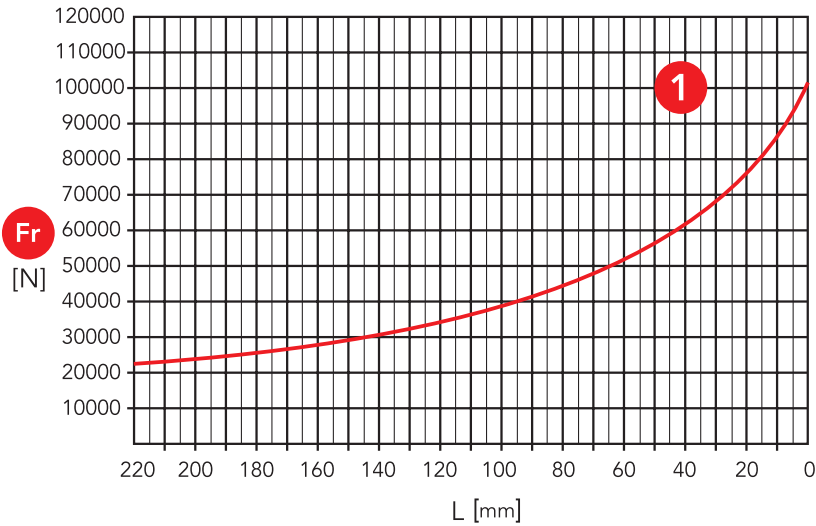

1 Uscita / Output: CMS, CMC, CCPC

CHPL / CHPLB 10000

CARICHI ASSIALI (Fa) · AXIAL LOADS (Fa)

Nella tabella seguente sono indicati i carichi assiali Fa (N) applicabili sull'albero di uscita in funzione della direzione di applicazione del carico e della versione.

The hereunder table shows the allowable axial loads Fa (N) on the output shaft with reference to the load direction and the output type.

	1	
Fa [N]	40000	←
	65000	→

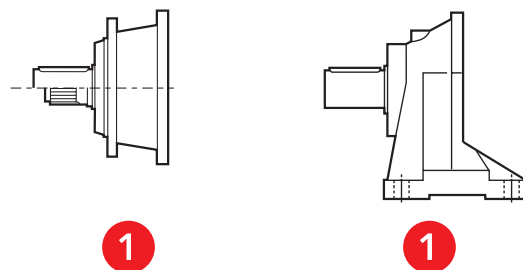

1 Uscita / Output: CMS, CMC, CCPC

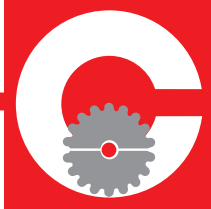



CHPL

	<i>i</i>	
16001	3.56 ÷ 6.75	1 reduction stage
16002	13.4 ÷ 48.9	2 reduction stages
16003	57.6 ÷ 330.3	3 reduction stages
16004	352.0 ÷ 2229.7	4 reduction stages

OUT

IN

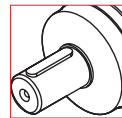

Ø100

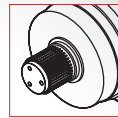

80x74
100x94
DIN 5482

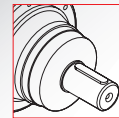

Ø42
Ø65

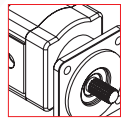

Hydraulic
Motor

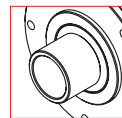

Ø120

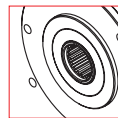

80x74
DIN 5482

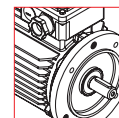

Electric
Motor

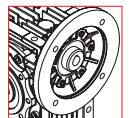

Worm
gearboxes

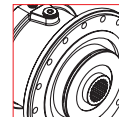

Brake

CHPLB

	<i>i</i>	
16002	12.3 ÷ 36.7	2 reduction stages
16003	46.4 ÷ 266.4	3 reduction stages
16004	140.1 ÷ 969.0	4 reduction stages

OUT

IN

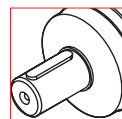

Ø100

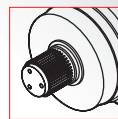

80x74
100x94
DIN 5482

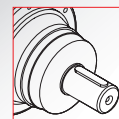

Ø42
Ø65

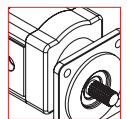

Hydraulic
Motor

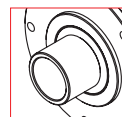

Ø120

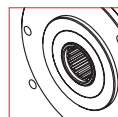

80x74
DIN 5482

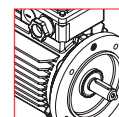

Electric
Motor

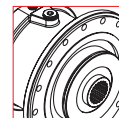

Brake

DATI TECNICI · TECHNICAL DATA

CHPL	i	T _{2n}	P _{1n}	T ₂ Max	P _t	IEC		CHM	CM/CP
		(n ₁ = 1400 rpm) 10.000h FS=1 [Nm]	(n ₁ = 1400 rpm) 10.000h FS=1 [kW]	[Nm]	1400 rpm [kW]	(B5)			
16001	3.56	7352	312	36760	40	160 200	180 225	CHM 110 CHM 130	CM65 CP65
	4.29	6609	234	32020					
	5.6	5308	144	24500					
	6.75	4399	99	18620					
16002	13.4	9447	111	36760	23	63 80 100 132 180	71 90 112 160	CHM 50 CHM 63 CHM 75 CHM 90 CHM 110 CHM 130	CM42 CM65 CP65
	16.2	8378	81.4	32020					
	22.1	8956	63.8	32020					
	28.9	7271	39.6	24500					
	33.6	7514	35.2	24500					
	40.5	5660	22	18620					
	48.9	6151	19.8	18620					
16003	57.6	12181	34.5	36760	15	63 80 100 132	71 90 112 160	CHM 50 CHM 63 CHM 75 CHM 90	CM42
	62.9	12147	31.5	36760					
	75.2	12447	27	36760					
	82.1	12833	25.5	36760					
	94.9	11344	19.5	32020					
	109.3	12060	18	32020					
	118.5	8717	12	24500					
	124	12543	16.5	32020					
	129.4	9519	12	24500					
	144	9538	10.8	24500					
	155.9	9558	10	24500					
	188.2	10153	8.8	24500					
	195.3	10060	8.4	24500					
	209.7	7713	6	18620					
	226.8	10010	7.2	24500					
	235.4	8081	5.6	18620					
274.1	10754	6.4	24500						
330.3	8099	4	18620						
16004	352	16243	7.8	36760	11	63 80 100 132	71 90 112 160	CHM 50 CHM 63 CHM 75 CHM 90	CM42
	388.6	16551	7.2	36760					
	421.2	17193	6.9	36760					
	440.9	14866	5.7	32020					
	459.9	17139	6.3	36760					
	507.7	18020	6	36760					
	531.4	15088	4.8	32020					
	554.4	17711	5.4	36760					
	576.1	12269	3.6	24500					
	612	16299	4.5	32020					
	640.5	15913	4.2	32020					
	724.4	12257	2.86	24500					
	806.4	12593	2.64	24500					
	907.3	12990	2.42	24500					
	1008.9	17069	2.86	32020					
	1093.7	13523	2.09	24500					
	1270.1	14050	1.87	24500					
1530.9	14942	1.65	24500						
1849.8	14445	1.32	24500						
2229.7	11608	0.88	18620						



n_{1max} = 2800 rpm

per ulteriori rapporti consultare l'ufficio tecnico

for information consult the technical office

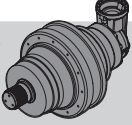

DATI TECNICI · TECHNICAL DATA

 CHPLB	i	T_{2n} ($n_1 = 1400$ rpm) 10.000h FS=1 [Nm]	P_{1n} ($n_1 = 1400$ rpm) 10.000h FS=1 [kW]	T_2 Max [Nm]	P_t 1400 rpm [kW]	IEC		 CM/CP
						(B5)		
16002	12.3	9142	117	36760	23	63 80 100 132 180	71 90 112 160	CM42 CM65 CP65
	14.8	8462	90	32020				
	19.3	6621	54	24500				
	23.3	5328	36	18620				
	30.5	7265	37.5	24500				
	36.7	5945	25.5	18620				
16003	46.4	11945	42	36760	15	63 80 100 132	71 90 112 160	CM42 CM65 CP65
	50.7	12121	39	36760				
	61.1	10675	28.5	32020				
	76.5	11255	24	32020				
	88.8	11431	21	32020				
	96.2	11500	19.5	32020				
	116.1	9003	12.65	24500				
	120.6	12198	16.5	32020				
	125.8	9331	12.1	24500				
	140	12272	14.3	32020				
	157.5	9558	9.9	24500				
	182.9	9866	8.8	24500				
	221	10432	7.7	24500				
	266.4	8084	4.95	18620				
16004	140.1	16162	19.5	36760	11	63 80 100 132	71 90 112 160	CM42 CM65 CP65
	168.9	16485	16.5	36760				
	184.4	14726	13.5	32020				
	203.5	14445	12	32020				
	230.9	15366	11.25	32020				
	240.9	11757	8.25	24500				
	290.4	15461	9	32020				
	301.8	12051	6.75	24500				
	320.6	15647	8.25	32020				
	347.5	12662	6.16	24500				
	379.5	12348	5.5	24500				
	418.9	12540	5.06	24500				
	457.4	13097	4.84	24500				
	510.4	13284	4.4	24500				
	551.9	13646	4.18	24500				
	665.3	13853	3.52	24500				
	803.9	14647	3.08	24500				
	969	11349	1.98	18620				

CHPLB 16000

$n_{1max} = 2800$ rpm

per ulteriori rapporti consultare l'ufficio tecnico

for information consult the technical office

DIMENSIONI · DIMENSIONS

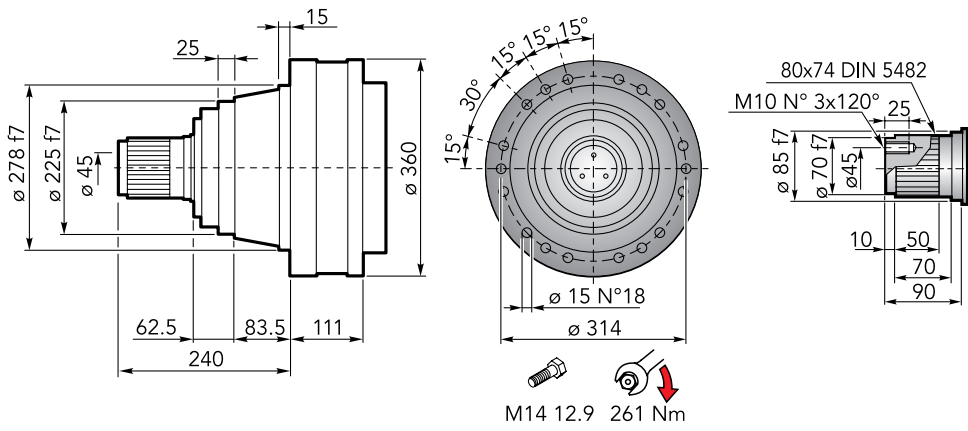

Accessori Accessories

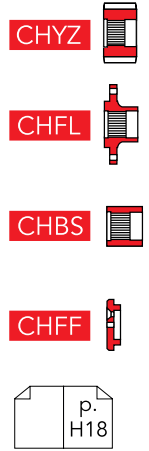

CHPL 16000 CMS - Flange motori IEC | IEC Motor flanges

CHPL	IEC 63			IEC 71			IEC 80			IEC 90			IEC 100		
	LP	P	ØD	LP	P	ØD	LP	P	ØD	LP	P	ØD	LP	P	ØD
16001	-			-			-			-			-		
16002	248.5			248.5			268.5			268.5			278.5		
16003	309.5	36	140	309.5	36	160	329.5	56	200	329.5	56	200	339.5	66	250
16004	357.5			357.5			377.5			377.5			387.5		

CHPL	IEC 112			IEC 132			IEC 160			IEC 180			IEC 200			IEC 225		
	LP	P	ØD	LP	P	ØD	LP	P	ØD	LP	P	ØD	LP	P	ØD	LP	P	ØD
16001	-			-			259	118	350	259	118	350	289	148	400	280	139	450
16002	278.5			312.5			351.5			351.5	139	350	-			-		
16003	339.5	66	250	373.5	100	300	412.5	139	350	-			-			-		
16004	387.5			421.5			460.5			-			-			-		

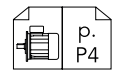
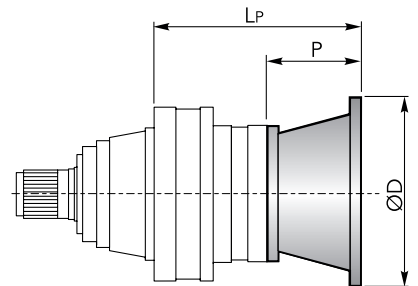

CHPL 16000 CMS - Alberi maschi entrata | Male input shafts

CHPL	CM42				CM65				CP65			
	LT	T	LE	ØE	LT	T	LE	ØE	LT	T	LE	ØE
16001	-				262.5	121.5	105	65 h6	294	153	105	65 h6
16002	305.5				347.5				379			
16003	366.5	93	82	42 h6	-			-				
16004	414.5				-			-				

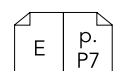
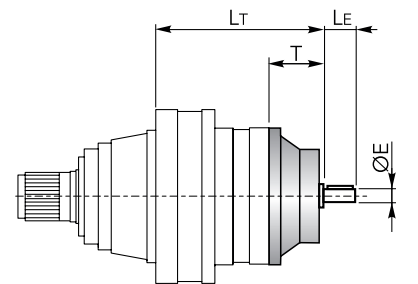



DIMENSIONI · DIMENSIONS

CHPL 16000 CMS - Riduttore a vite senza fine CHM in entrata | *CHM input worm gearboxes*

CHPL	CHM 50					CHM 63					CHM 75				
	Lv	I	H	M	N	Lv	I	H	M	N	Lv	I	H	M	N
16001	-					-					-				
16002	338					347.5					326.5				
16003	399	50	110	60	80	408.5	63	135	72	95	387.5	75	161	86	112.5
16004	447					456.5					435.5				

CHPL	CHM 90					CHM 110					CHM 130					
	Lv	I	H	M	N	Lv	I	H	M	N	Lv	I	H	M	N	
16001	-					279					286					
16002	336.5					364	110	237.5	127.5	160	371	130	277.5	147.5	180	
16003	397.5	90	193	103	129.5	-					-					
16004	445.5					-					-					

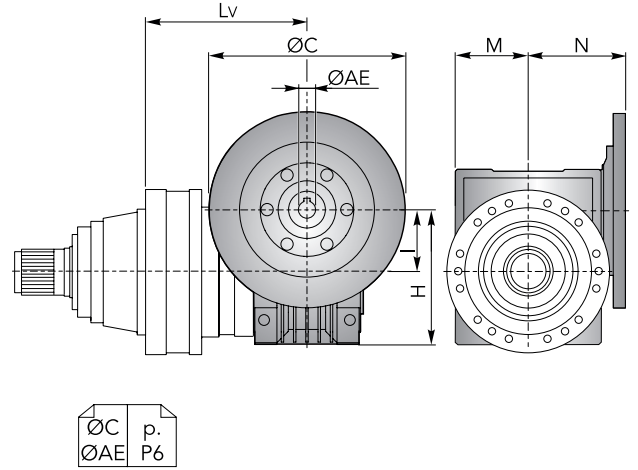

CHPL / CHPLB 16000 CMS

CHPLB 16000 CMS - Flange motori IEC | *IEC Motor flanges*

CHPLB	IEC 63				IEC 71				IEC 80				IEC 90			
	L	Lp	P	ØD	L	Lp	P	ØD	L	Lp	P	ØD	L	Lp	P	ØD
16002	229	276	36	140	229	276	36	160	229	296	56	200	229	296	56	200
16003	314				314				314				314			
16004	348.5	196			348.5	196			348.5	216			348.5	216		

CHPLB	IEC 100				IEC 112				IEC 132				IEC 160				IEC 180			
	L	Lp	P	ØD	L	Lp	P	ØD	L	Lp	P	ØD	L	Lp	P	ØD	L	Lp	P	ØD
16002	229	306	66	250	229	306	66	250	229	340	100	300	229	379	139	350	229	379	139	350
16003	314				314				314				314				314			
16004	348.5	226			348.5	226			348.5	260			348.5	299						

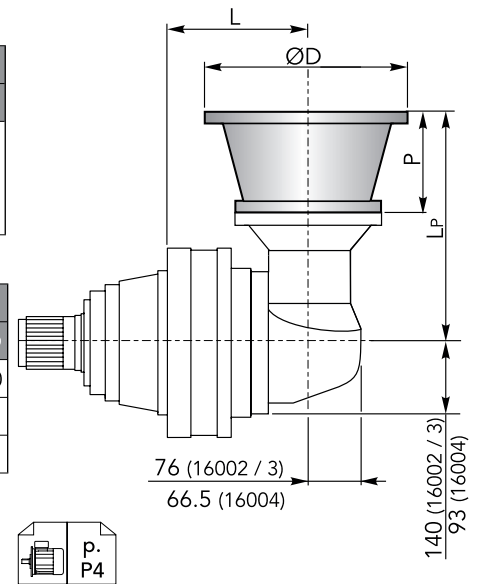

CHPLB 16000 CMS - Alberi maschi entrata | *Male input shafts*

CHPLB	CM42					CM65					CP65				
	L	Lt	T	Le	ØE	L	Lt	T	Le	ØE	L	Lt	T	Le	ØE
16002	229	333	93	82	42 h6	229	377.5	121.5	105	65 h6	229	409	153	105	65 h6
16003	314					314					314				
16004	348.5	253				348.5	297.5				348.5	329			

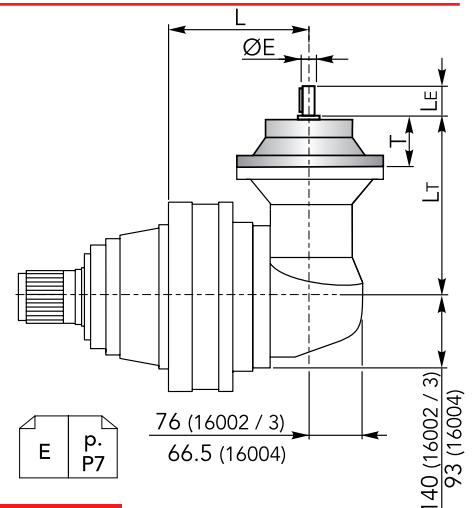

DIMENSIONI · DIMENSIONS

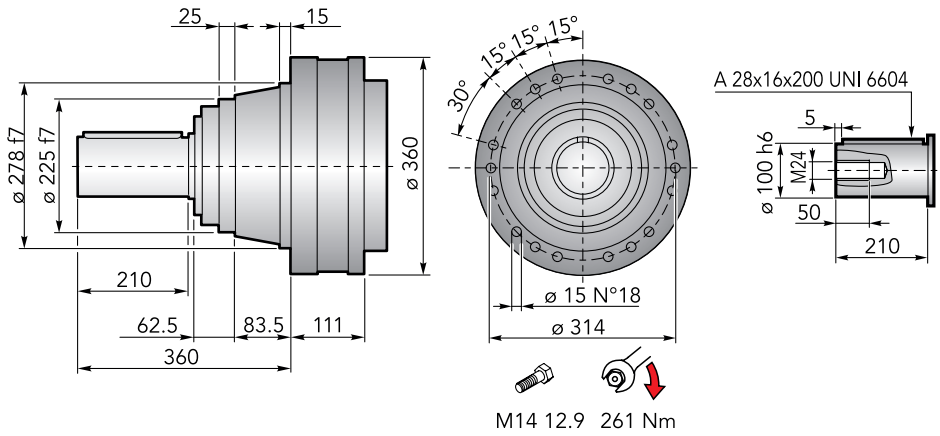

CHPL 16000 CMC - Flange motori IEC | IEC Motor flanges

CHPL	IEC 63			IEC 71			IEC 80			IEC 90			IEC 100		
	LP	P	ØD	LP	P	ØD	LP	P	ØD	LP	P	ØD	LP	P	ØD
16001	-			-			-			-			-		
16002	248.5			248.5			268.5			268.5			278.5		
16003	309.5	36	140	309.5	36	160	329.5	56	200	329.5	56	200	339.5	66	250
16004	357.5			357.5			377.5			377.5			387.5		

CHPL	IEC 112			IEC 132			IEC 160			IEC 180			IEC 200			IEC 225		
	LP	P	ØD	LP	P	ØD	LP	P	ØD	LP	P	ØD	LP	P	ØD	LP	P	ØD
16001	-			-			259	118	350	259	118	350	289	148	400	280	139	450
16002	278.5			312.5			351.5			351.5	139	350	-			-		
16003	339.5	66	250	373.5	100	300	412.5	139	350	-			-			-		
16004	387.5			421.5			460.5			-			-			-		

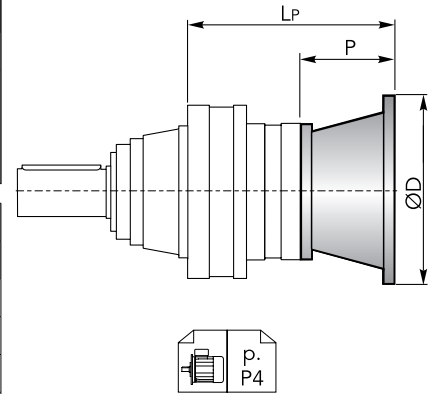

CHPL 16000 CMC - Alberi maschi entrata | Male input shafts

CHPL	CM42				CM65				CP65			
	LT	T	LE	ØE	LT	T	LE	ØE	LT	T	LE	ØE
16001	-				262.5	121.5	105	65 h6	294	153	105	65 h6
16002	305.5				347.5				379			
16003	366.5	93	82	42 h6	-			-				
16004	414.5				-			-				

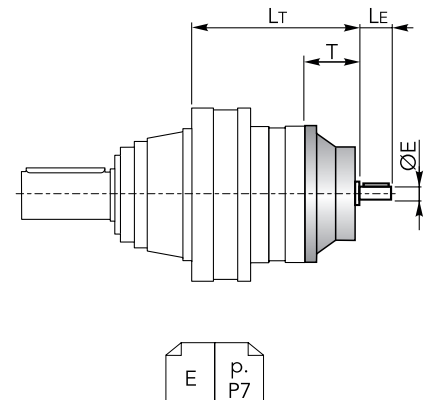



DIMENSIONI · DIMENSIONS

CHPL 16000 CMC - Riduttore a vite senza fine CHM in entrata | *CHM input worm gearboxes*

CHPL	CHM 50					CHM 63					CHM 75				
	Lv	I	H	M	N	Lv	I	H	M	N	Lv	I	H	M	N
16001	-					-					-				
16002	338					347.5					326.5				
16003	399	50	110	60	80	408.5	63	135	72	95	387.5	75	161	86	112.5
16004	447					456.5					435.5				

CHPL	CHM 90					CHM 110					CHM 130				
	Lv	I	H	M	N	Lv	I	H	M	N	Lv	I	H	M	N
16001	-					-					-				
16002	336.5					279	110	237.5	127.5	160	286	130	277.5	147.5	180
16003	397.5	90	193	103	129.5	-					-				
16004	445.5					-					-				

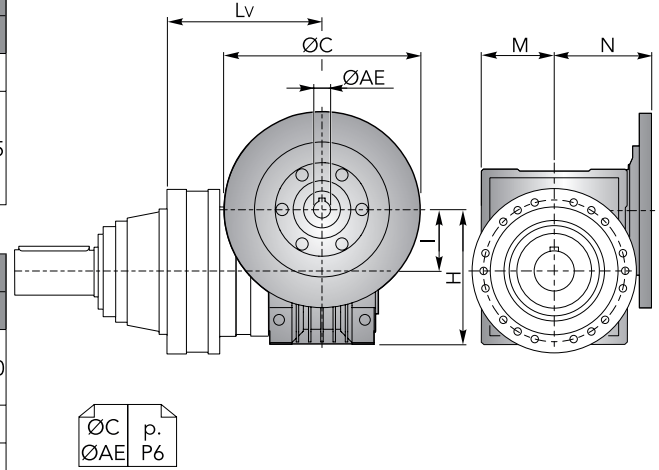

CHPL / CHPLB 16000 CMC

CHPLB 16000 CMC - Flange motori IEC | *IEC Motor flanges*

CHPLB	IEC 63				IEC 71				IEC 80				IEC 90			
	L	LP	P	ØD	L	LP	P	ØD	L	LP	P	ØD	L	LP	P	ØD
16002	229	276	36	140	229	276	36	160	229	296	56	200	229	296	56	200
16003	314				314				314				314			
16004	348.5	196			348.5	196			348.5	216			348.5	216		

CHPLB	IEC 100				IEC 112				IEC 132				IEC 160				IEC 180			
	L	LP	P	ØD	L	LP	P	ØD	L	LP	P	ØD	L	LP	P	ØD	L	LP	P	ØD
16002	229	306	66	250	229	306	66	250	229	340	100	300	229	379	139	350	229	379	139	350
16003	314				314				314				314				314			
16004	348.5	226			348.5	226			348.5	260			348.5	299						

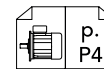
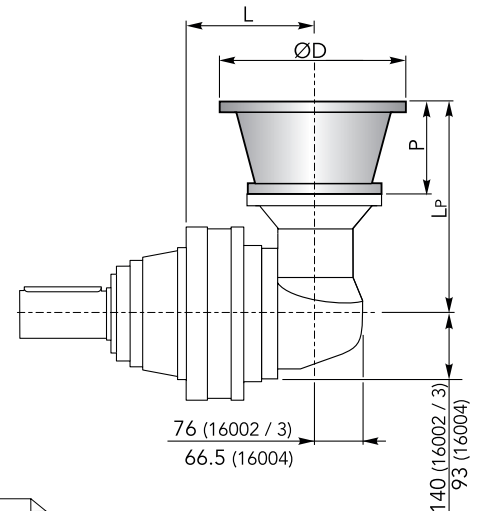

CHPLB 16000 CMC - Alberi maschi entrata | *Male input shafts*

CHPLB	CM42					CM65					CP65				
	L	Lt	T	Le	ØE	L	Lt	T	Le	ØE	L	Lt	T	Le	ØE
16002	229	333	93	82	42 h6	229	377.5	121.5	105	65 h6	229	409	153	105	65 h6
16003	314					314					314				
16004	348.5	253				348.5	297.5				348.5	329			

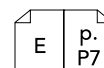
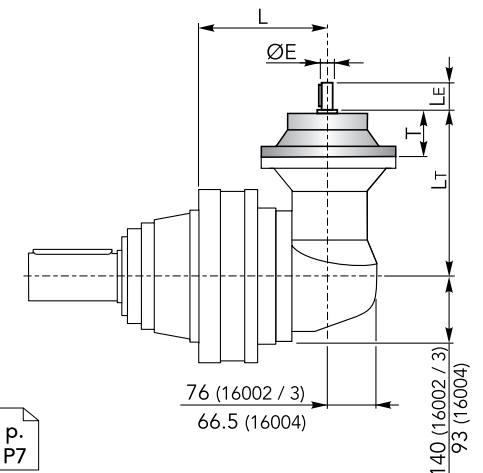

DIMENSIONI · DIMENSIONS

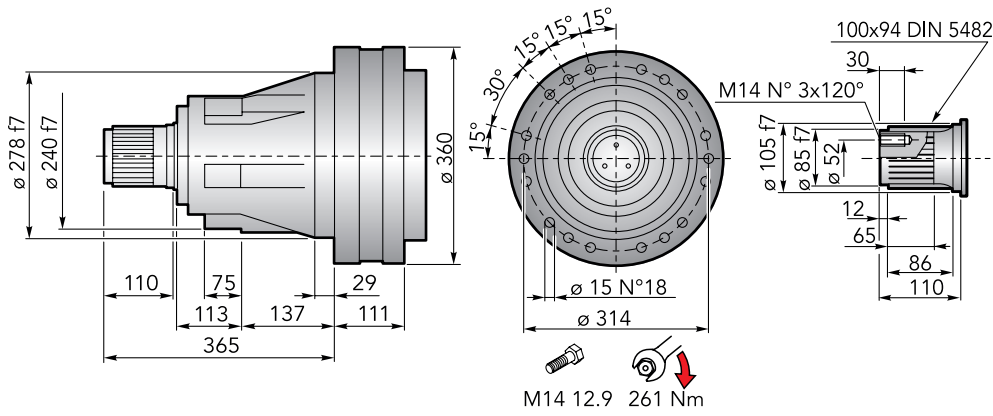

Accessori
Accessories



CHPL 16000 CPS - Flange motori IEC | IEC Motor flanges

CHPL	IEC 63			IEC 71			IEC 80			IEC 90			IEC 100		
	LP	P	ØD	LP	P	ØD	LP	P	ØD	LP	P	ØD	LP	P	ØD
16001	-	-	-	-	-	-	-	-	-	-	-	-	-	-	-
16002	248.5	-	-	248.5	-	-	268.5	-	-	268.5	-	-	278.5	-	-
16003	309.5	36	140	309.5	36	160	329.5	56	200	329.5	56	200	339.5	66	250
16004	357.5	-	-	357.5	-	-	377.5	-	-	377.5	-	-	387.5	-	-

CHPL	IEC 112			IEC 132			IEC 160			IEC 180			IEC 200			IEC 225		
	LP	P	ØD	LP	P	ØD	LP	P	ØD	LP	P	ØD	LP	P	ØD	LP	P	ØD
16001	-	-	-	-	-	-	259	118	350	259	118	350	289	148	400	280	139	450
16002	278.5	-	-	312.5	-	-	351.5	-	-	351.5	139	350	-	-	-	-	-	-
16003	339.5	66	250	373.5	100	300	412.5	139	350	-	-	-	-	-	-	-	-	-
16004	387.5	-	-	421.5	-	-	460.5	-	-	-	-	-	-	-	-	-	-	-

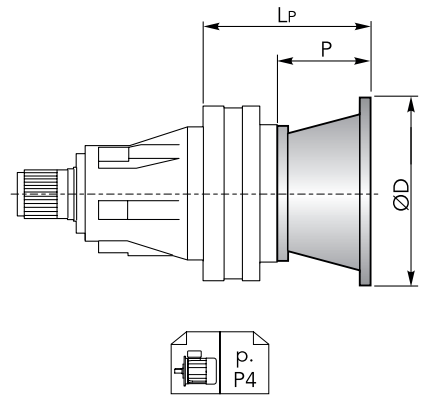

CHPL 16000 CPS - Alberi maschi entrata | Male input shafts

CHPL	CM42				CM65				CP65			
	LT	T	LE	ØE	LT	T	LE	ØE	LT	T	LE	ØE
16001	-	-	-	-	262.5	121.5	105	65 h6	294	153	105	65 h6
16002	305.5	-	-	-	347.5	-	-	-	379	-	-	-
16003	366.5	93	82	42 h6	-	-	-	-	-	-	-	-
16004	414.5	-	-	-	-	-	-	-	-	-	-	-

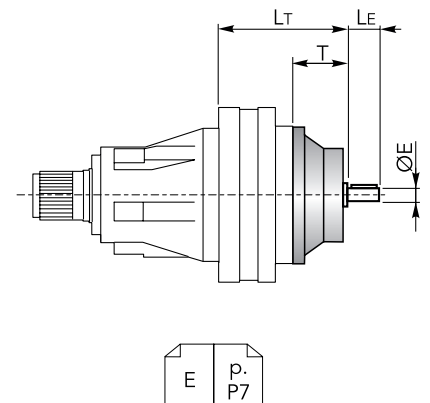



DIMENSIONI · DIMENSIONS

CHPL 16000 CPS - Riduttore a vite senza fine CHM in entrata | *CHM input worm gearboxes*

CHPL	CHM 50					CHM 63					CHM 75				
	Lv	I	H	M	N	Lv	I	H	M	N	Lv	I	H	M	N
16001	-					-					-				
16002	338					347.5					326.5				
16003	399	50	110	60	80	408.5	63	135	72	95	387.5	75	161	86	112.5
16004	447					456.5					435.5				

CHPL	CHM 90					CHM 110					CHM 130					
	Lv	I	H	M	N	Lv	I	H	M	N	Lv	I	H	M	N	
16001	-					279					286					
16002	336.5					364	110	237.5	127.5	160	371	130	277.5	147.5	180	
16003	397.5	90	193	103	129.5	-					-					
16004	445.5					-					-					

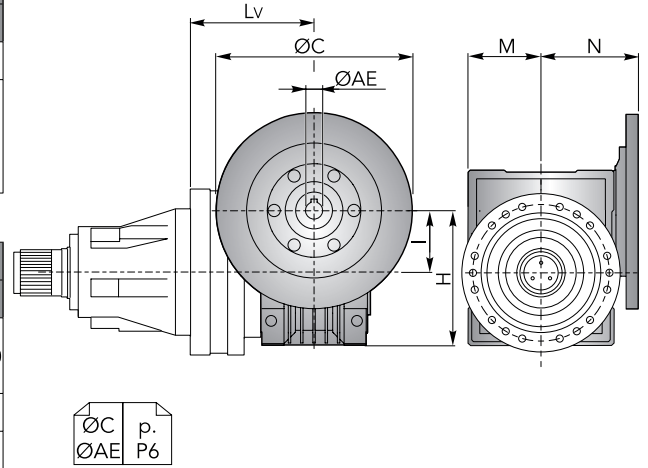

CHPL / CHPLB 16000 CPS

CHPLB 16000 CPS - Flange motori IEC | *IEC Motor flanges*

CHPLB	IEC 63				IEC 71				IEC 80				IEC 90			
	L	Lp	P	ØD	L	Lp	P	ØD	L	Lp	P	ØD	L	Lp	P	ØD
16002	229				229				229				229			
16003	314	276	36	140	314	276	36	160	314	296	56	200	314	296	56	200
16004	348.5	196			348.5	196			348.5	216			348.5	216		

CHPLB	IEC 100				IEC 112				IEC 132				IEC 160				IEC 180			
	L	Lp	P	ØD	L	Lp	P	ØD	L	Lp	P	ØD	L	Lp	P	ØD	L	Lp	P	ØD
16002	229				229				229				229				229	379	139	350
16003	314	306	66	250	314	306	66	250	314	340	100	300	314	379	139	350	-			
16004	348.5	226			348.5	226			348.5	260			348.5	299			-			

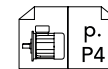
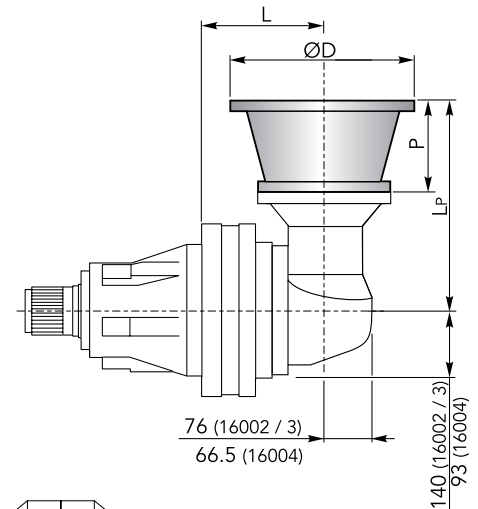

CHPLB 16000 CPS - Alberi maschi entrata | *Male input shafts*

CHPLB	CM42					CM65					CP65				
	L	Lt	T	Le	ØE	L	Lt	T	Le	ØE	L	Lt	T	Le	ØE
16002	229					229					229				
16003	314	333	93	82	42 h6	314	377.5	121.5	105	65 h6	314	409	153	105	65 h6
16004	348.5	253				348.5	297.5				348.5	329			

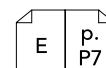
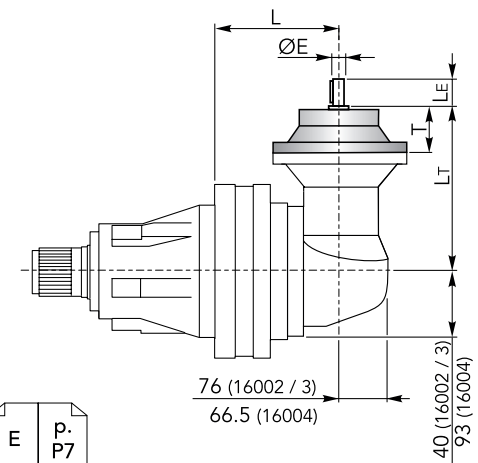

DIMENSIONI · DIMENSIONS

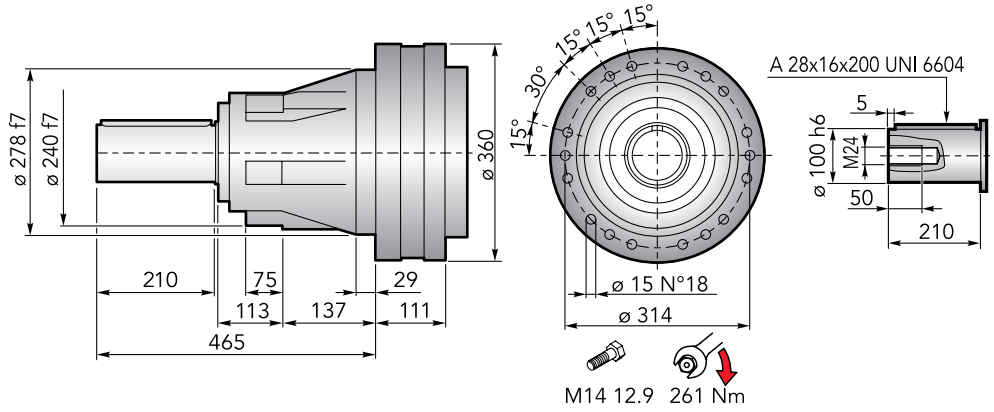

CHPL 16000 CPC - Flange motori IEC | IEC Motor flanges

CHPL	IEC 63			IEC 71			IEC 80			IEC 90			IEC 100		
	LP	P	ØD	LP	P	ØD	LP	P	ØD	LP	P	ØD	LP	P	ØD
16001	-			-			-			-			-		
16002	248.5			248.5			268.5			268.5			278.5		
16003	309.5	36	140	309.5	36	160	329.5	56	200	329.5	56	200	339.5	66	250
16004	357.5			357.5			377.5			377.5			387.5		

CHPL	IEC 112			IEC 132			IEC 160			IEC 180			IEC 200			IEC 225		
	LP	P	ØD	LP	P	ØD	LP	P	ØD	LP	P	ØD	LP	P	ØD	LP	P	ØD
16001	-			-			259	118	350	259	118	350	289	148	400	280	139	450
16002	278.5			312.5			351.5			351.5	139	350	-			-		
16003	339.5	66	250	373.5	100	300	412.5	139	350	-			-			-		
16004	387.5			421.5			460.5			-			-			-		

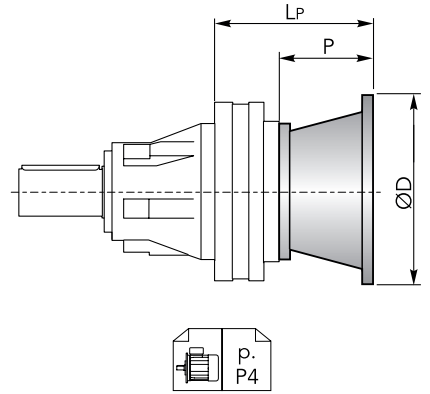

CHPL 16000 CPC - Alberi maschi entrata | Male input shafts

CHPL	CM42				CM65				CP65			
	LT	T	LE	ØE	LT	T	LE	ØE	LT	T	LE	ØE
16001	-				262.5	121.5	105	65 h6	294	153	105	65 h6
16002	305.5				347.5				379			
16003	366.5	93	82	42 h6	-			-				
16004	414.5				-			-				

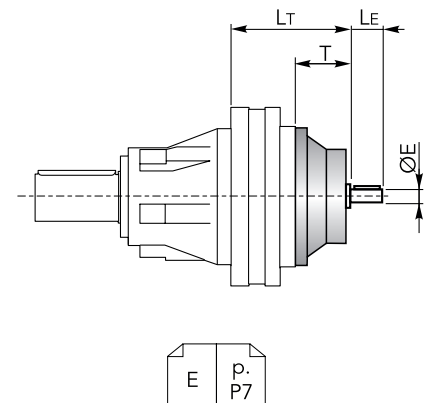



DIMENSIONI · DIMENSIONS

CHPL 16000 CPC - Riduttore a vite senza fine CHM in entrata | *CHM input worm gearboxes*

CHPL	CHM 50					CHM 63					CHM 75				
	Lv	I	H	M	N	Lv	I	H	M	N	Lv	I	H	M	N
16001	-					-					-				
16002	338					347.5					326.5				
16003	399	50	110	60	80	408.5	63	135	72	95	387.5	75	161	86	112.5
16004	447					456.5					435.5				

CHPL	CHM 90					CHM 110					CHM 130					
	Lv	I	H	M	N	Lv	I	H	M	N	Lv	I	H	M	N	
16001	-					279	110	237.5	127.5	160	286	130	277.5	147.5	180	
16002	336.5					364					371					
16003	397.5	90	193	103	129.5	-					-					
16004	445.5					-					-					

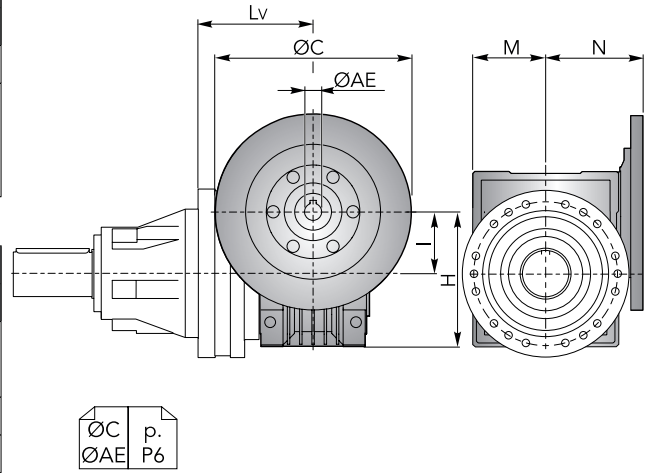

CHPL / CHPLB 16000 CPC

CHPLB 16000 CPC - Flange motori IEC | *IEC Motor flanges*

CHPLB	IEC 63				IEC 71				IEC 80				IEC 90			
	L	LP	P	ØD	L	LP	P	ØD	L	LP	P	ØD	L	LP	P	ØD
16002	229				229				229				229			
16003	314	276	36	140	314	276	36	160	314	296	56	200	314	296	56	200
16004	348.5	196			348.5	196			348.5	216			348.5	216		

CHPLB	IEC 100				IEC 112				IEC 132				IEC 160				IEC 180			
	L	LP	P	ØD	L	LP	P	ØD	L	LP	P	ØD	L	LP	P	ØD	L	LP	P	ØD
16002	229				229				229				229				229	379	139	350
16003	314	306	66	250	314	306	66	250	314	340	100	300	314	379	139	350	-			
16004	348.5	226			348.5	226			348.5	260			348.5	299			-			

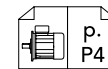
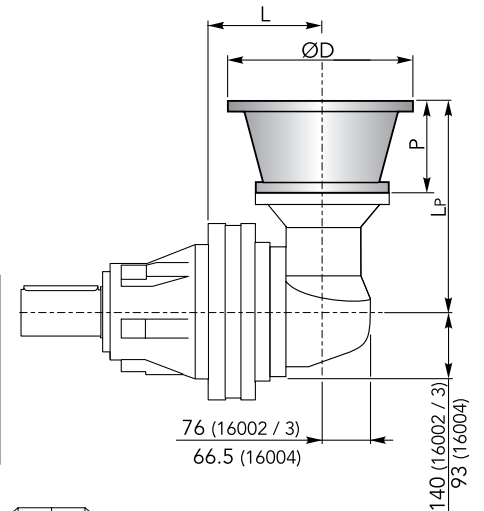

CHPLB 16000 CPC - Alberi maschi entrata | *Male input shafts*

CHPLB	CM42					CM65					CP65				
	L	Lt	T	Le	ØE	L	Lt	T	Le	ØE	L	Lt	T	Le	ØE
16002	229					229					229				
16003	314	333	93	82	42 h6	314	377.5	121.5	105	65 h6	314	409	153	105	65 h6
16004	348.5	253				348.5	297.5				348.5	329			

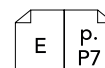
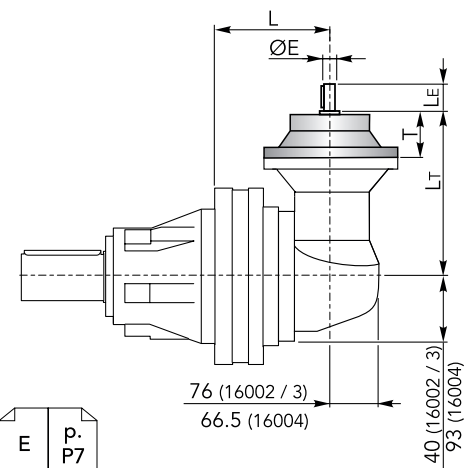



DIMENSIONI · DIMENSIONS

CHPL 16000 CF - Riduttore a vite senza fine CHM in entrata | CHM input worm gearboxes

CHPL	CHM 50					CHM 63					CHM 75				
	Lv	I	H	M	N	Lv	I	H	M	N	Lv	I	H	M	N
16001	-					-					-				
16002	328					337.5					316.5				
16003	389	50	110	60	80	398.5	63	135	72	95	377.5	75	161	86	112.5
16004	437					446.5					425.5				

CHPL	CHM 90					CHM 110					CHM 130				
	Lv	I	H	M	N	Lv	I	H	M	N	Lv	I	H	M	N
16001	-					-					-				
16002	326.5					354	110	237.5	127.5	160	276	130	277.5	147.5	180
16003	387.5	90	193	103	129.5										
16004	435.5														

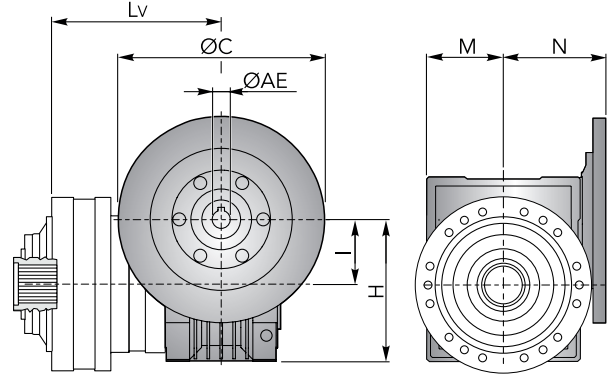

CHPL / CHPLB 16000 CF

CHPLB 16000 CF - Flange motori IEC | IEC Motor flanges

CHPLB	IEC 63				IEC 71				IEC 80				IEC 90			
	L	Lp	P	ØD	L	Lp	P	ØD	L	Lp	P	ØD	L	Lp	P	ØD
16002	219				219				219				219			
16003	304	276	36	140	304	276	36	160	304	296	56	200	304	296	56	200
16004	338.5	196			338.5	196			338.5	216			338.5	216		

CHPLB	IEC 100				IEC 112				IEC 132				IEC 160				IEC 180				
	L	Lp	P	ØD	L	Lp	P	ØD	L	Lp	P	ØD	L	Lp	P	ØD	L	Lp	P	ØD	
16002	219				219				219				219				219				350
16003	304	306	66	250	304	306	66	250	304	340	100	300	304	379	139	350					
16004	338.5	226			338.5	226			338.5	260			338.5	299							

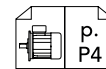
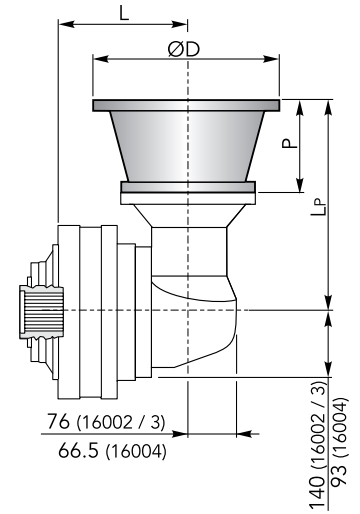

CHPLB 16000 CF - Alberi maschi entrata | Male input shafts

CHPLB	CM42					CM65					CP65				
	L	Lt	T	Le	ØE	L	Lt	T	Le	ØE	L	Lt	T	Le	ØE
16002	219					219					219				
16003	304	333	93	82	42 h6	304	377.5	121.5	105	65 h6	304	409	153	105	65 h6
16004	338.5	253				338.5	297.5				338.5	329			

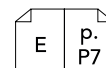
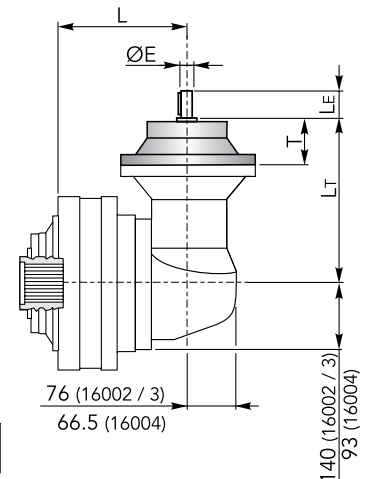

DIMENSIONI · DIMENSIONS

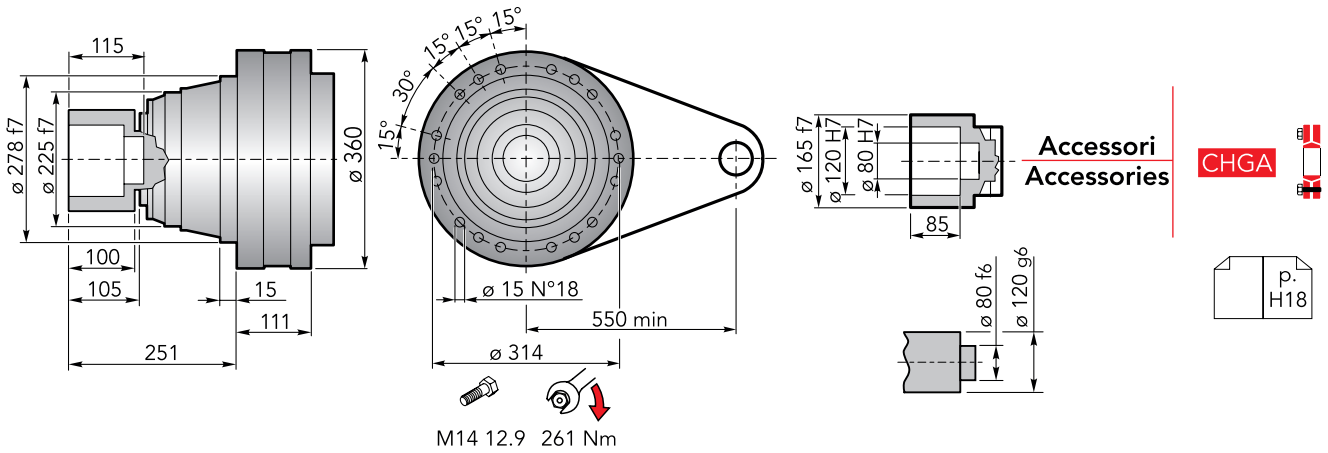

CHPL 16000 CFS - Flange motori IEC | IEC Motor flanges

CHPL	IEC 63			IEC 71			IEC 80			IEC 90			IEC 100		
	LP	P	ØD	LP	P	ØD	LP	P	ØD	LP	P	ØD	LP	P	ØD
16001	-			-			-			-			-		
16002	248.5			248.5			268.5			268.5			278.5		
16003	309.5	36	140	309.5	36	160	329.5	56	200	329.5	56	200	339.5	66	250
16004	357.5			357.5			377.5			377.5			387.5		

CHPL	IEC 112			IEC 132			IEC 160			IEC 180			IEC 200			IEC 225		
	LP	P	ØD	LP	P	ØD	LP	P	ØD	LP	P	ØD	LP	P	ØD	LP	P	ØD
16001	-			-			259	118	350	259	118	350	289	148	400	280	139	450
16002	278.5			312.5			351.5			351.5	139	350	-			-		
16003	339.5	66	250	373.5	100	300	412.5	139	350	-			-			-		
16004	387.5			421.5			460.5			-			-			-		

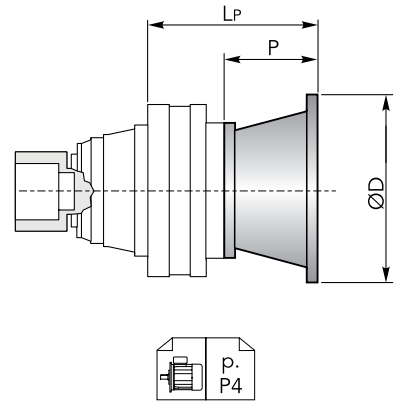

CHPL 16000 CFS - Alberi maschi entrata | Male input shafts

CHPL	CM42				CM65				CP65				
	LT	T	LE	ØE	LT	T	LE	ØE	LT	T	LE	ØE	
16001	-				262.5				294				
16002	305.5				347.5	121.5	105	65 h6	379	153	105	65 h6	
16003	366.5	93	82	42 h6	-				-				
16004	414.5				-				-				

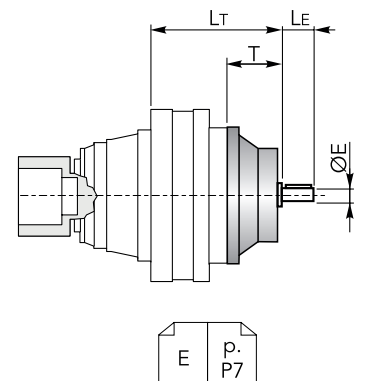



DIMENSIONI · DIMENSIONS

CHPL 16000 CFS - Riduttore a vite senza fine CHM in entrata | CHM input worm gearboxes

CHPL	CHM 50					CHM 63					CHM 75				
	Lv	I	H	M	N	Lv	I	H	M	N	Lv	I	H	M	N
16001	-					-					-				
16002	338					347.5					326.5				
16003	399	50	110	60	80	408.5	63	135	72	95	387.5	75	161	86	112.5
16004	447					456.5					435.5				

CHPL	CHM 90					CHM 110					CHM 130					
	Lv	I	H	M	N	Lv	I	H	M	N	Lv	I	H	M	N	
16001	-					279	110	237.5	127.5	160	286	130	277.5	147.5	180	
16002	336.5					364					371					
16003	397.5	90	193	103	129.5	-					-					
16004	445.5					-					-					

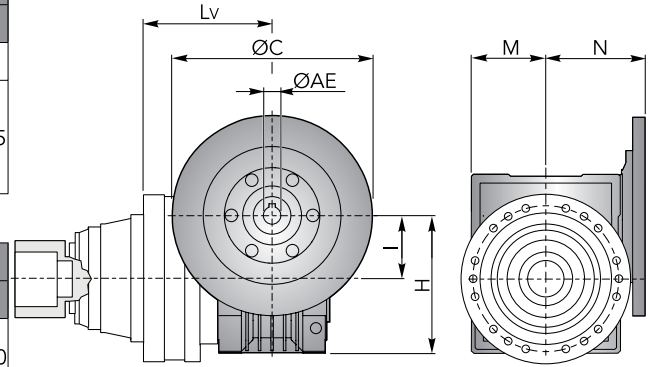

CHPL / CHPLB 16000 CFS

CHPLB 16000 CFS - Flange motori IEC | IEC Motor flanges

CHPLB	IEC 63				IEC 71				IEC 80				IEC 90			
	L	Lp	P	ØD	L	Lp	P	ØD	L	Lp	P	ØD	L	Lp	P	ØD
16002	229				229				229				229			
16003	314	276	36	140	314	276	36	160	314	296	56	200	314	296	56	200
16004	348.5	196			348.5	196			348.5	216			348.5	216		

CHPLB	IEC 100				IEC 112				IEC 132				IEC 160				IEC 180			
	L	Lp	P	ØD	L	Lp	P	ØD	L	Lp	P	ØD	L	Lp	P	ØD	L	Lp	P	ØD
16002	229				229				229				229				229	379	139	350
16003	314	306	66	250	314	306	66	250	314	340	100	300	314	379	139	350	-			
16004	348.5	226			348.5	226			348.5	260			348.5	299			-			

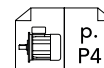
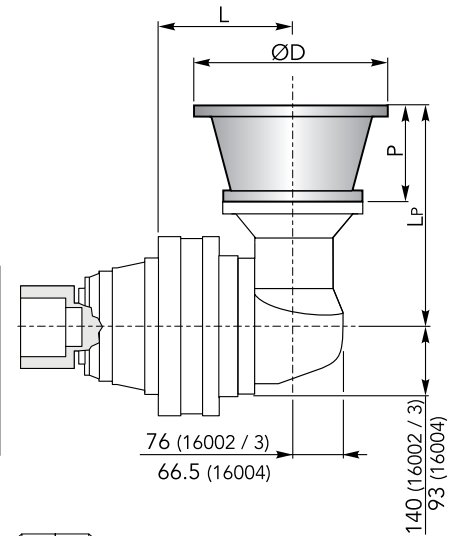

CHPLB 16000 CFS - Alberi maschi entrata | Male input shafts

CHPLB	CM42					CM65					CP65				
	L	Lt	T	Le	ØE	L	Lt	T	Le	ØE	L	Lt	T	Le	ØE
16002	229					229					229				
16003	314	333	93	82	42 h6	314	377.5	121.5	105	65 h6	314	409	153	105	65 h6
16004	348.5	253				348.5	297.5				348.5	329			

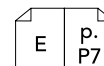
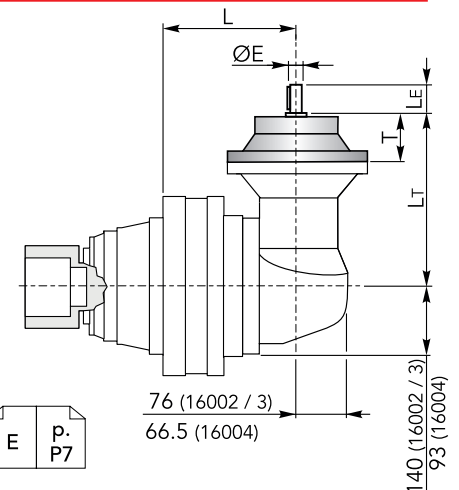

DIMENSIONI · DIMENSIONS

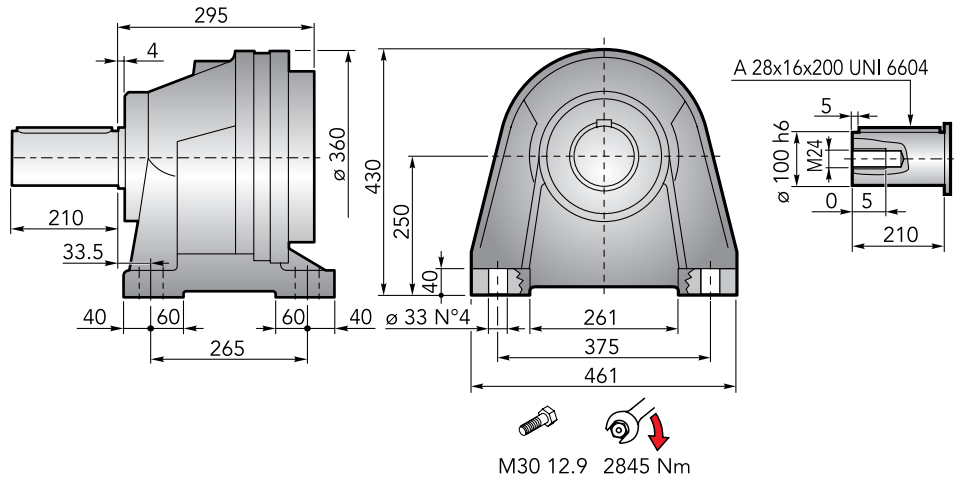

CHPL 16000 CCPC - Flange motori IEC | IEC Motor flanges

CHPL	IEC 63			IEC 71			IEC 80			IEC 90			IEC 100		
	LP	P	ØD	LP	P	ØD	LP	P	ØD	LP	P	ØD	LP	P	ØD
16001	-	-	-	-	-	-	-	-	-	-	-	-	-	-	-
16002	352.5	-	-	352.5	-	-	372.5	-	-	372.5	-	-	382.5	-	-
16003	463.5	36	140	463.5	36	160	483.5	56	200	483.5	56	200	493.5	66	250
16004	511.5	-	-	511.5	-	-	531.5	-	-	531.5	-	-	541.5	-	-

CHPL	IEC 112			IEC 132			IEC 160			IEC 180			IEC 200			IEC 225		
	LP	P	ØD	LP	P	ØD	LP	P	ØD	LP	P	ØD	LP	P	ØD	LP	P	ØD
16001	-	-	-	-	-	-	413	118	350	413	118	350	443	148	400	434	139	450
16002	382.5	-	-	416.5	-	-	455.5	-	-	455.5	139	350	-	-	-	-	-	-
16003	493.5	66	250	527.5	100	300	566.5	139	350	-	-	-	-	-	-	-	-	-
16004	541.5	-	-	575.5	-	-	614.5	-	-	-	-	-	-	-	-	-	-	-

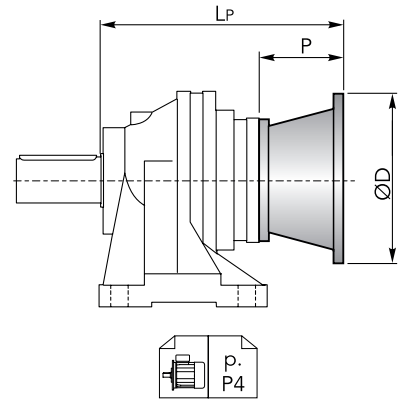

CHPL 16000 CCPC - Alberi maschi entrata | Male input shafts

CHPL	CM42				CM65				CP65			
	LT	T	LE	ØE	LT	T	LE	ØE	LT	T	LE	ØE
16001	-	-	-	-	416.5	121.5	105	65 h6	448	153	105	65 h6
16002	409.5	-	-	-	451.5	-	-	-	483	-	-	-
16003	520.5	93	82	42 h6	-	-	-	-	-	-	-	-
16004	568.5	-	-	-	-	-	-	-	-	-	-	-

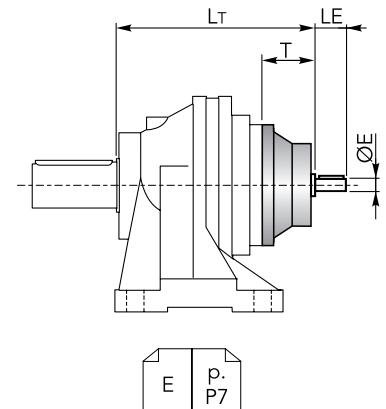



DIMENSIONI · DIMENSIONS

CHPL 16000 CCPC - Riduttore a vite senza fine CHM in entrata | CHM input worm gearboxes

CHPL	CHM 50					CHM 63					CHM 75				
	Lv	I	H	M	N	Lv	I	H	M	N	Lv	I	H	M	N
16001	-					-					-				
16002	442					451.5					430.5				
16003	553	50	110	60	80	562.5	63	135	72	95	541.5	75	161	86	112.5
16004	601					610.5					589.5				

CHPL	CHM 90					CHM 110					CHM 130					
	Lv	I	H	M	N	Lv	I	H	M	N	Lv	I	H	M	N	
16001	-					433					440					
16002	440.5					468	110	237.5	127.5	160	475	130	277.5	147.5	180	
16003	551.5	90	193	103	129.5	-					-					
16004	599.5					-					-					

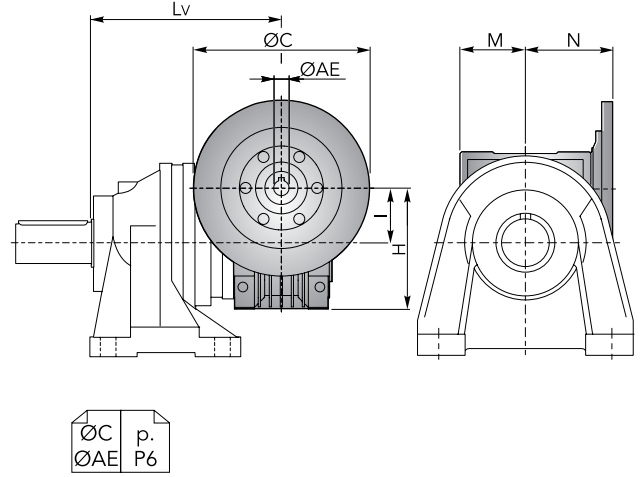

CHPL / CHPLB 16000 CCPC

CHPLB 16000 CCPC - Flange motori IEC | IEC Motor flanges

CHPLB	IEC 63				IEC 71				IEC 80				IEC 90			
	L	Lp	P	ØD	L	Lp	P	ØD	L	Lp	P	ØD	L	Lp	P	ØD
16002	383				383				383				383			
16003	468	276	36	140	468	276	36	160	468	296	56	200	468	296	56	200
16004	502.5	196			502.5	196			502.5	216			502.5	216		

CHPLB	IEC 100				IEC 112				IEC 132				IEC 160				IEC 180			
	L	Lp	P	ØD	L	Lp	P	ØD	L	Lp	P	ØD	L	Lp	P	ØD	L	Lp	P	ØD
16002	383				383				383				383				383			
16003	468	306	66	250	468	306	66	250	468	340	100	300	468	379	139	350	-			
16004	502.5	226			502.5	226			502.5	260			502.5	299			-			

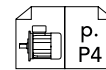
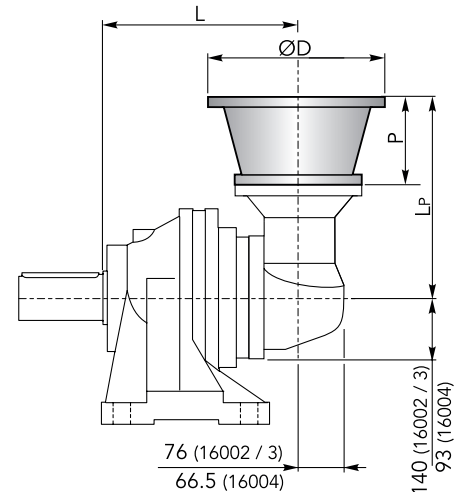

CHPLB 16000 CCPC - Alberi maschi entrata | Male input shafts

CHPLB	CM42					CM65					CP65				
	L	Lt	T	Le	ØE	L	Lt	T	Le	ØE	L	Lt	T	Le	ØE
16002	383					383					383				
16003	468	333	93	82	42 h6	468	377.5	121.5	105	65 h6	468	409	153	105	65 h6
16004	502.5	253				502.5	297.5				502.5	329			

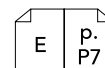
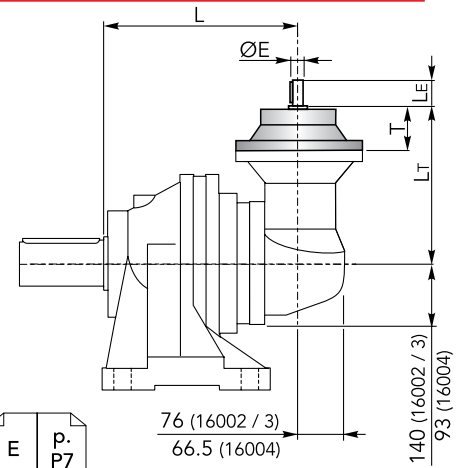

ACCESSORI · ACCESSORIES

CHYZ



Pignoni | Pinions

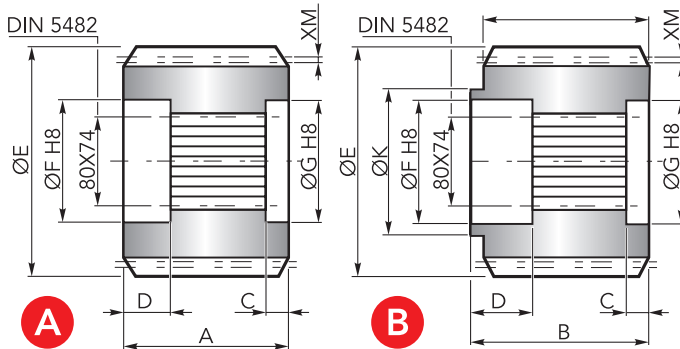

	Uscita / Output	M	Z	XM	A	B	C	D	E	F	G	K	Codice / Code
A	CMS	10	12	0	90	-	10	31	140	85	80	-	1071.236.042
	CMS	10	14	0	90	-	10	31	160	85	80	-	1071.238.042
	CPS	14	13	7	122	-	24	33	224	105	105	-	1071.293.042
B	CMS	12	14	3	90	115	25	31	194.5	85	80	130	1071.286.042

CHFF



Fondello di arresto | Stop bottom plate

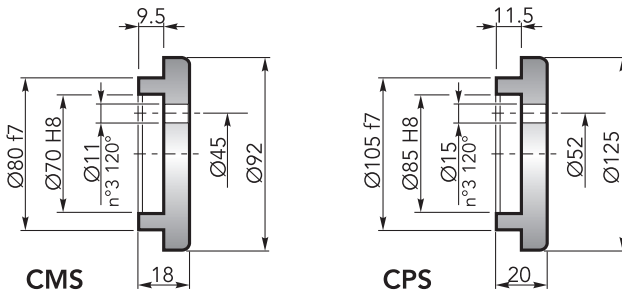

CMS

Codice / Code:
1075.030.000

CPS

Codice / Code:
1075.042.000

CHBS



Boccola scanalata | Splined bushing

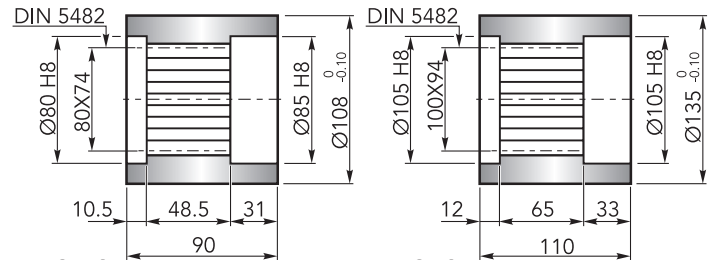

CMS

Codice / Code:
6171.103.076

CPS

Codice / Code:
8171.112.041

CHKB

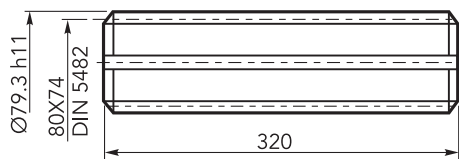

Barra scanalata | Splined rod

Codice / Code:
3071.406.042

CHGA

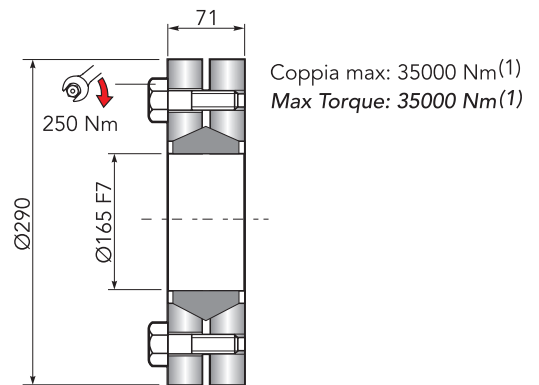

Giunto di attrito | Shrink disc

Codice / Code:
5109.165.000

CHFL



Flangia | Flange

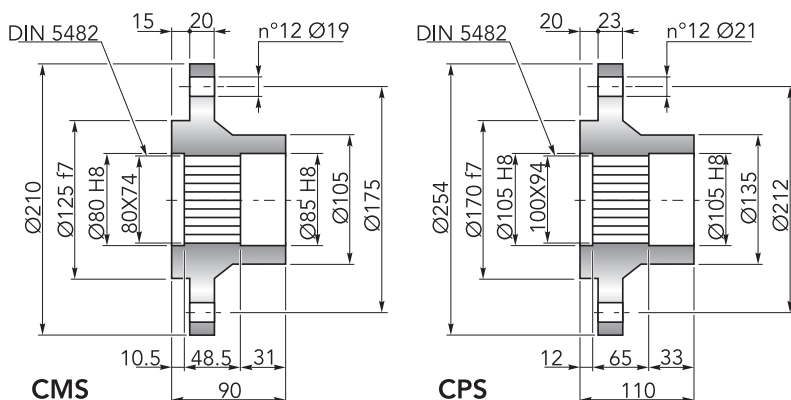

CMS

Codice / Code:
6171.105.098

CPS

Codice / Code:
8171.104.098

(1): Coppia max indicata è valida solo con calettatori forniti da Chiaravalli S.p.A.

(1): The maximum torque indicated is valid only with shrink discs supplied by Chiaravalli S.p.A.



CARICHI RADIALI (Fr) · RADIAL LOADS (Fr)

Nel diagramma seguente, sono indicati i carichi radiali F_r (N) applicabili sull'albero uscita in funzione della distanza di applicazione L rispetto alla battuta dell'albero.

The hereunder table shows the allowable radial loads F_r (N) on the output shaft with reference to the distance L .

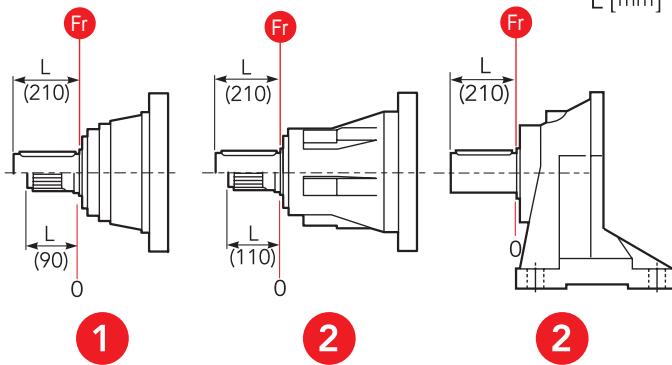
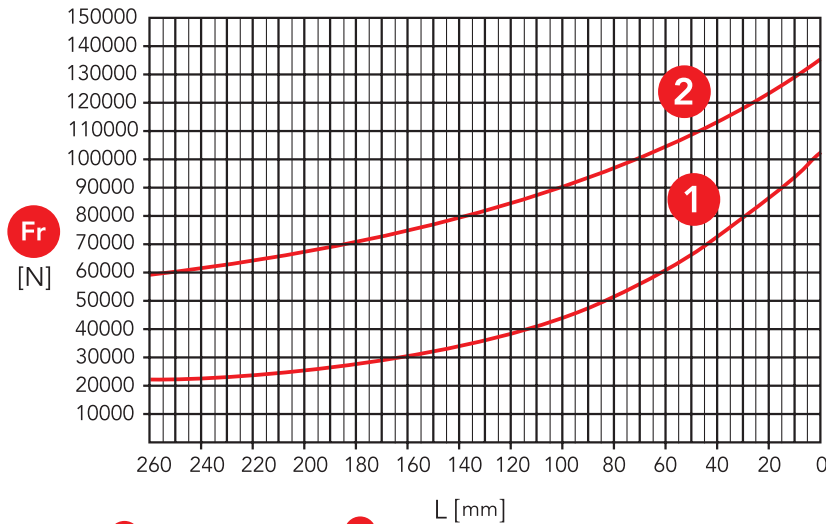

- 1** Uscita / Output: CMS, CMC
- 2** Uscita / Output: CPS, CPC, CCPC

CARICHI ASSIALI (Fa) · AXIAL LOADS (Fa)

Nella tabella seguente sono indicati i carichi assiali F_a (N) applicabili sull'albero di uscita in funzione della direzione di applicazione del carico e della versione.

The hereunder table shows the allowable axial loads F_a (N) on the output shaft with reference to the load direction and the output type.

	1	2	
Fa [N]	45000	85000	←
	65000	85000	→

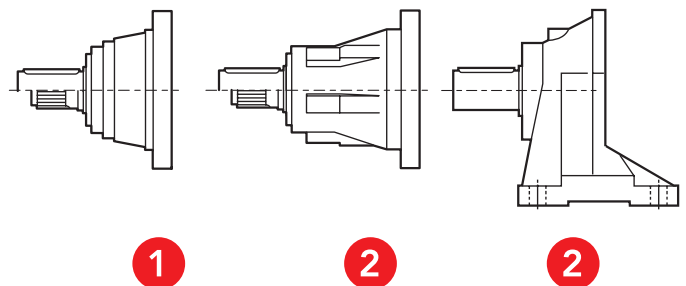

- 1** Uscita / Output: CMS, CMC
- 2** Uscita / Output: CPS, CPC, CCPC

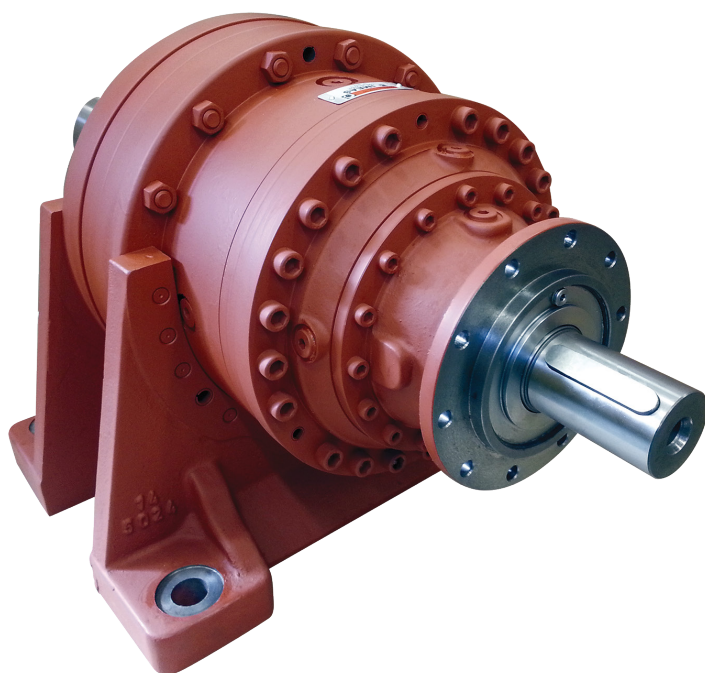



CHPL

18002	i 13.0 ÷ 30.0	2 reduction stages
18003	53.8 ÷ 180.2	3 reduction stages
18004	348.6 ÷ 1216.4	4 reduction stages

OUT

IN

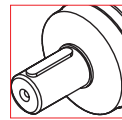

Ø100

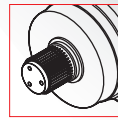

80x74
100x94
DIN 5482

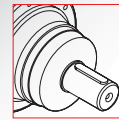

Ø42
Ø65

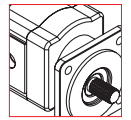

Hydraulic
Motor

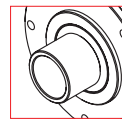

Ø120

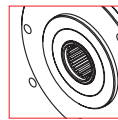

80x74
DIN 5482

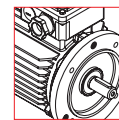

Electric
Motor

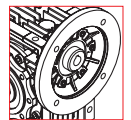

Worm
gearboxes

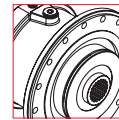

Brake

CHPLB

18002	i 10.9 ÷ 20.0	2 reduction stages
18003	54.4 ÷ 163.3	3 reduction stages
18004	185.8 ÷ 981.2	4 reduction stages

OUT

IN

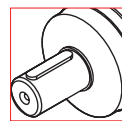

Ø100

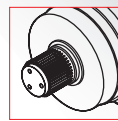

80x74
100x94
DIN 5482

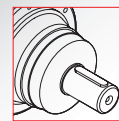

Ø42
Ø65

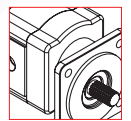

Hydraulic
Motor

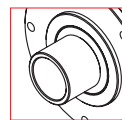

Ø120

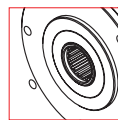

80x74
DIN 5482

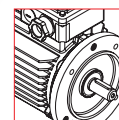

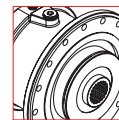

Electric
Motor

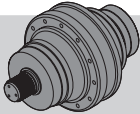
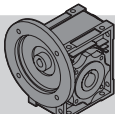

Brake

DATI TECNICI · TECHNICAL DATA

 CHPL	i	T _{2n} (n ₁ = 1400 rpm) 10.000h FS=1 [Nm]	P _{1n} (n ₁ = 1400 rpm) 10.000h FS=1 [kW]	T ₂ Max [Nm]	P _t 1400 rpm [kW]	IEC (B5)	 CHM	 CM/CP
18002	13	9290	112.5	36760	40	160 180 200	CHM 110 CHM 130	CM65 CP65
	15.7	9874	99	36760				
	19	8690	72	32020				
	21.4	9176	67.5	32020				
	24.9	9254	58.5	32020				
	30	9434	49.5	32020				
18003	53.8	11873	36	36760	23	63 71 80 90 100 112 132 160 180	CHM 50 CHM 63 CHM 75 CHM 90 CHM 110 CHM 130	CM42 CM65 CP65
	65	12552	31.5	36760				
	73.3	12806	28.5	36760				
	81.4	12725	25.5	36760				
	94.5	13034	22.5	36760				
	106.7	13736	21	36760				
	128.4	11806	15	32020				
	149.1	12339	13.5	32020				
	180.2	13256	12	32020				
18004	348.6	16703	8.1	36760	11	63 71 80 90 100 112 132 160	CHM 50 CHM 63 CHM 75 CHM 90	CM42
	377.2	16735	7.5	36760				
	438.4	16116	6.6	36760				
	489.2	17362	6	36760				
	549.1	17539	5.4	36760				
	620	18706	5.1	36760				
	677.9	18045	4.5	36760				
	720	19166	4.5	36760				
	770.5	19143	4.2	36760				
	818.8	18891	3.9	36760				
	849.8	16589	3.3	32020				
	928.8	16483	3	32020				
	987.4	17523	3	32020				
	1113	17777	2.7	32020				
	1216.4	17270	2.4	32020				

n_{lmax} = 2800 rpm

per ulteriori rapporti consultare l'ufficio tecnico

for information consult the technical office

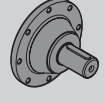

DATI TECNICI · TECHNICAL DATA

 CHPLB	i	T _{2n} (n ₁ = 1400 rpm) 10.000h FS=1 [Nm]	P _{1n} (n ₁ = 1400 rpm) 10.000h FS=1 [kW]	T ₂ Max [Nm]	P _t 1400 rpm [kW]	IEC (B5)	 CM/CP
18002	10.9	9037	128	36760	25	160 180	CM65 CP65
	13.2	8301	99	32020			
	16.6	9965	94.5	36760			
	20	8576	67.5	32020			
18003	54.4	12005	36	36760	17	63 71 80 90 100 112 132 160	CM42 CM65 CP65
	71.2	12440	28.5	36760			
	85.7	13396	25.5	36760			
	103.3	11398	18	32020			
	116.7	11803	16.5	32020			
	135.5	13705	16.5	36760			
	163.3	12012	12	32020			
18004	185.8	15113	13.7	36760	13	63 71 80 90 100 112 132 160	CM42 CM65 CP65
	224.4	15333	11.6	36760			
	281	15542	9.4	36760			
	323.8	16089	8.4	36760			
	353.6	16315	7.8	36760			
	394.3	16793	7.2	36760			
	442.9	17292	6.6	36760			
	500.1	17750	6	36760			
	558.2	15850	4.8	32020			
	580.7	17519	5.1	36760			
	622.5	15466	4.2	32020			
	699.2	16131	3.9	32020			
	749.1	16953	3.6	32020			
	812	17292	3.6	32020			
	981.2	17413	3	32020			

n_{1max} = 2800 rpm

per ulteriori rapporti consultare l'ufficio tecnico

for information consult the technical office

DIMENSIONI · DIMENSIONS

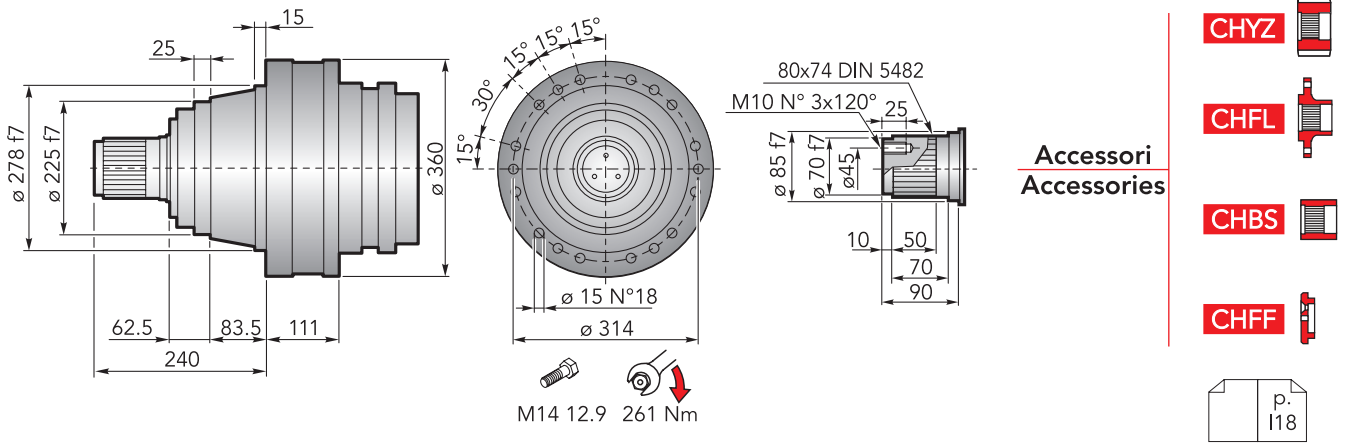

CHPL 18000 CMS - Flange motori IEC | IEC Motor flanges

CHPL	IEC 63			IEC 71			IEC 80			IEC 90			IEC 100		
	LP	P	ØD	LP	P	ØD	LP	P	ØD	LP	P	ØD	LP	P	ØD
18002	-			-			-			-			-		
18003	336.5	36	140	336.5	36	160	356.5	56	200	356.5	56	200	366.5	66	250
18004	380.5			380.5			400.5			400.5			410.5		

CHPL	IEC 112			IEC 132			IEC 160			IEC 180		
	LP	P	ØD	LP	P	ØD	LP	P	ØD	LP	P	ØD
18002	-			-			359	118	350	359	118	350
18003	366.5			400.5	100	300	439.5			-		
18004	410.5	66	250	444.5			483.5	139		-		

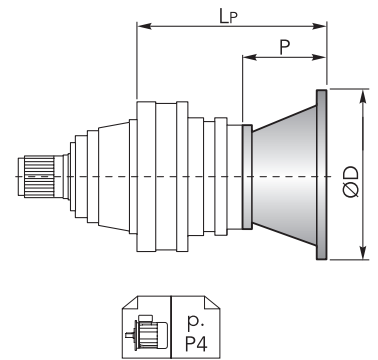

CHPL 18000 CMS - Alberi maschi entrata | Male input shafts

CHPL	CM42				CM65				CP65			
	LT	T	LE	ØE	LT	T	LE	ØE	LT	T	LE	ØE
18002	-				362.5	121.5	105	65 h6	394	153	105	65 h6
18003	393.5	93	82	42 h6	435.5				467			
18004	437.5				-				-			

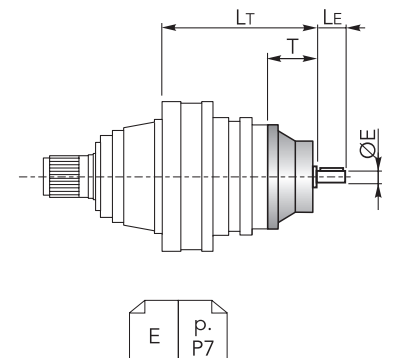



DIMENSIONI · DIMENSIONS

CHPL 18000 CMS - Riduttore a vite senza fine CHM in entrata | *CHM input worm gearboxes*

CHPL	CHM 50					CHM 63					CHM 75				
	Lv	I	H	M	N	Lv	I	H	M	N	Lv	I	H	M	N
18002	-					-					-				
18003	426	50	110	60	80	435.5	63	135	72	95	414.5	75	161	86	112.5
18004	470					479.5					458.5				

CHPL	CHM 90					CHM 110					CHM 130					
	Lv	I	H	M	N	Lv	I	H	M	N	Lv	I	H	M	N	
18002	-					379	110	237.5	127.5	160	386	130	277.5	147.5	180	
18003	424.5	90	193	103	129.5	452					459					
18004	468.5															

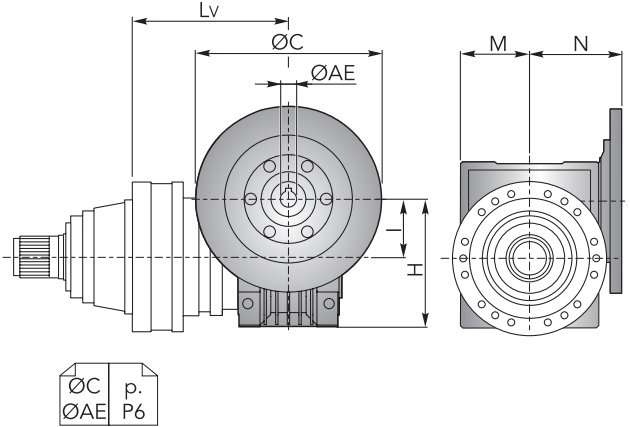

CHPL / CHPLB 18000 CMS

CHPLB 18000 CMS - Flange motori IEC | *IEC Motor flanges*

CHPLB	IEC 63				IEC 71				IEC 80				IEC 90			
	L	LP	P	ØD	L	LP	P	ØD	L	LP	P	ØD	L	LP	P	ØD
18002	-				-				-				-			
18003	333	276	36	140	333	276	36	160	333	296	56	200	333	296	56	200
18004	406				406				406				406			

CHPLB	IEC 100				IEC 112				IEC 132				IEC 160				IEC 180					
	L	LP	P	ØD	L	LP	P	ØD	L	LP	P	ØD	L	LP	P	ØD	L	LP	P	ØD		
18002	-				-				-				276	433	118	350	276	433	118	350		
18003	333	306	66	250	333	306	66	250	333	340	100	300	333	379	139	350						
18004	406				406				406				406									

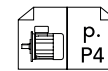
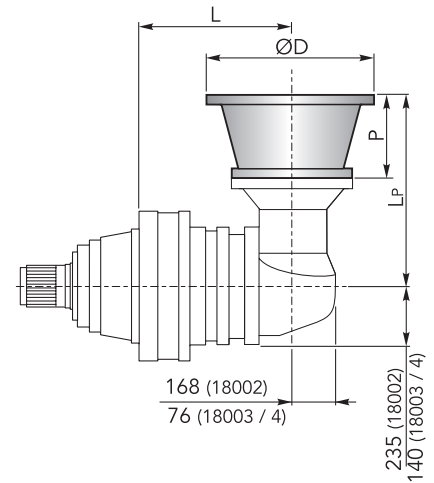

CHPLB 18000 CMS - Alberi maschi entrata | *Male input shafts*

CHPLB	CM42					CM65					CP65					
	L	Lt	T	Le	ØE	L	Lt	T	Le	ØE	L	Lt	T	Le	ØE	
18002	-					276	436.5				276	468				
18003	333	333	93	82	42 h6	333	377.5	121.5	105	65 h6	333	409	153	105	65 h6	
18004	406					406					406					

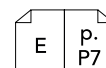
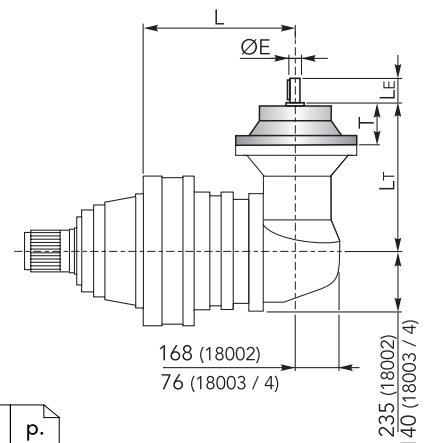

DIMENSIONI · DIMENSIONS

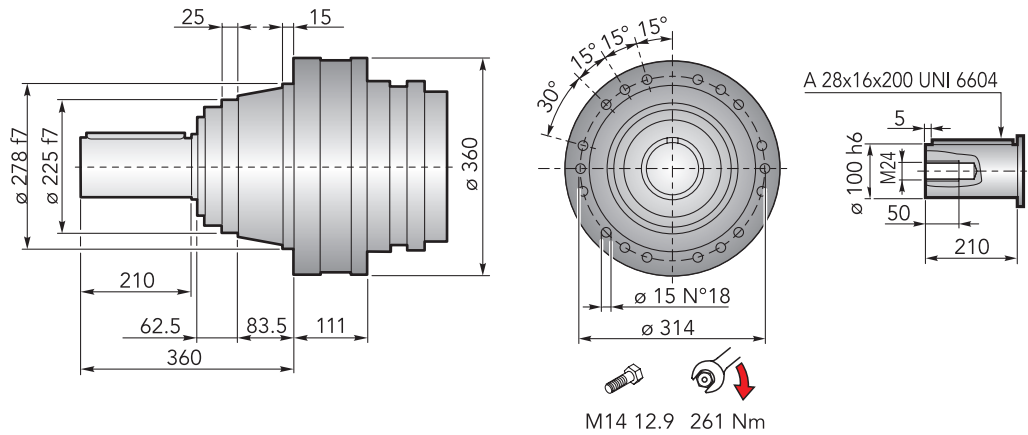

CHPL 18000 CMC - Flange motori IEC | IEC Motor flanges

CHPL	IEC 63			IEC 71			IEC 80			IEC 90			IEC 100		
	LP	P	ØD	LP	P	ØD	LP	P	ØD	LP	P	ØD	LP	P	ØD
18002	-			-			-			-			-		
18003	336.5	36	140	336.5	36	160	356.5	56	200	356.5	56	200	366.5	66	250
18004	380.5	36	140	380.5	36	160	400.5	56	200	400.5	56	200	410.5	66	250

CHPL	IEC 112			IEC 132			IEC 160			IEC 180		
	LP	P	ØD	LP	P	ØD	LP	P	ØD	LP	P	ØD
18002	-			-			359	118	350	359	118	350
18003	366.5	66	250	400.5	100	300	439.5	139		-		
18004	410.5	66	250	444.5	100	300	483.5	139		-		

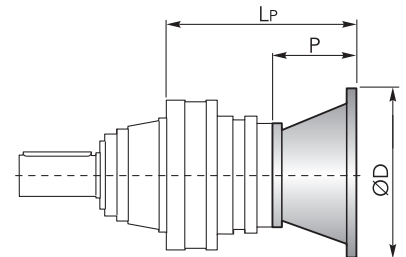

CHPL 18000 CMC - Alberi maschi entrata | Male input shafts

CHPL	CM42				CM65				CP65			
	LT	T	LE	ØE	LT	T	LE	ØE	LT	T	LE	ØE
18002	-				362.5	121.5	105	65 h6	394	153	105	65 h6
18003	393.5	93	82	42 h6	435.5	121.5	105	65 h6	467	153	105	65 h6
18004	437.5	93	82	42 h6	-				-			

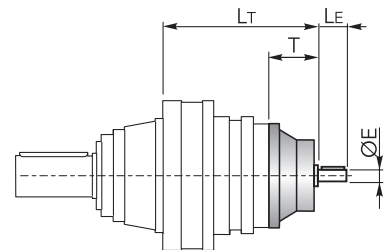



DIMENSIONI · DIMENSIONS

CHPL 18000 CMC - Riduttore a vite senza fine CHM in entrata | *CHM input worm gearboxes*

CHPL	CHM 50					CHM 63					CHM 75				
	Lv	I	H	M	N	Lv	I	H	M	N	Lv	I	H	M	N
18002	-					-					-				
18003	426	50	110	60	80	435.5	63	135	72	95	414.5	75	161	86	112.5
18004	470					479.5					458.5				

CHPL	CHM 90					CHM 110					CHM 130					
	Lv	I	H	M	N	Lv	I	H	M	N	Lv	I	H	M	N	
18002	-					379	110	237.5	127.5	160	386	130	277.5	147.5	180	
18003	424.5	90	193	103	129.5	452					459					
18004	468.5															

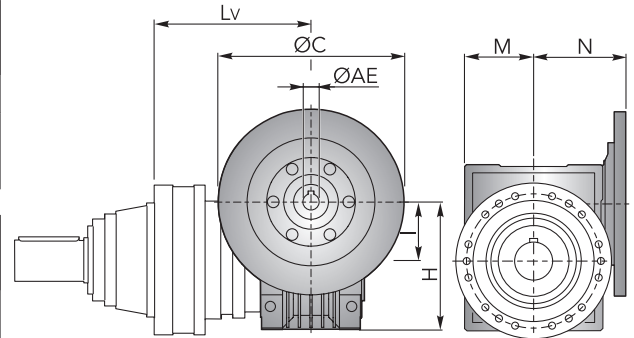

$\varnothing C$
 $\varnothing AE$

CHPL / CHPLB 18000 CMC

CHPLB 18000 CMC - Flange motori IEC | *IEC Motor flanges*

CHPLB	IEC 63				IEC 71				IEC 80				IEC 90			
	L	LP	P	ØD	L	LP	P	ØD	L	LP	P	ØD	L	LP	P	ØD
18002	-				-				-				-			
18003	333	276	36	140	333	276	36	160	333	296	56	200	333	296	56	200
18004	406				406				406				406			

CHPLB	IEC 100				IEC 112				IEC 132				IEC 160				IEC 180				
	L	LP	P	ØD	L	LP	P	ØD	L	LP	P	ØD	L	LP	P	ØD	L	LP	P	ØD	
18002	-				-				-				276	433	118	350	276	433	118	350	
18003	333	306	66	250	333	306	66	250	333	340	100	300	333	379	139	350					
18004	406				406				406				406								

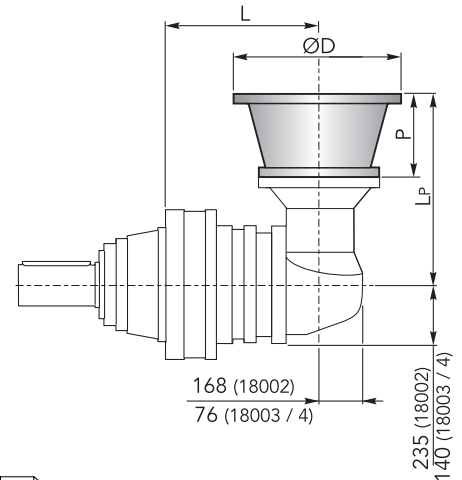

$\varnothing D$
 P
 LP

CHPLB 18000 CMC - Alberi maschi entrata | *Male input shafts*

CHPLB	CM42					CM65					CP65					
	L	L _T	T	L _E	ØE	L	L _T	T	L _E	ØE	L	L _T	T	L _E	ØE	
18002	-					276	436.5				276	468				
18003	333	333	93	82	42 h6	333	377.5	121.5	105	65 h6	333	409	153	105	65 h6	
18004	406					406					406					

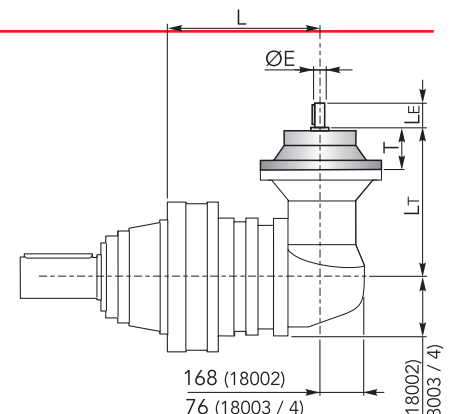

$\varnothing E$
 LE
 LT

DIMENSIONI · DIMENSIONS

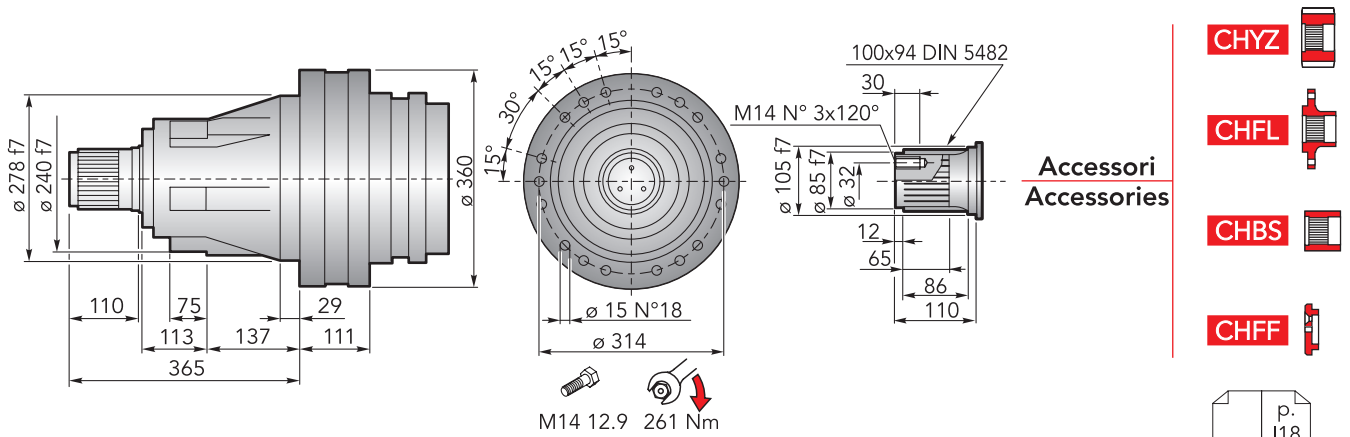

CHPL 18000 CPS - Flange motori IEC | IEC Motor flanges

CHPL	IEC 63			IEC 71			IEC 80			IEC 90			IEC 100		
	LP	P	ØD	LP	P	ØD	LP	P	ØD	LP	P	ØD	LP	P	ØD
18002	-			-			-			-			-		
18003	336.5	36	140	336.5	36	160	356.5	56	200	356.5	56	200	366.5	66	250
18004	380.5			380.5			400.5			400.5			410.5		

CHPL	IEC 112			IEC 132			IEC 160			IEC 180		
	LP	P	ØD	LP	P	ØD	LP	P	ØD	LP	P	ØD
18002	-			-			359	118	350	359	118	350
18003	366.5			400.5	100	300	439.5			-		
18004	410.5	66	250	444.5			483.5	139		-		

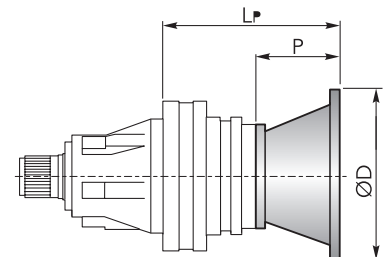

CHPL 18000 CPS - Alberi maschi entrata | Male input shafts

CHPL	CM42				CM65				CP65			
	LT	T	LE	ØE	LT	T	LE	ØE	LT	T	LE	ØE
18002	-				362.5	121.5	105	65 h6	394	153	105	65 h6
18003	393.5	93	82	42 h6	435.5				467			
18004	437.5				-				-			

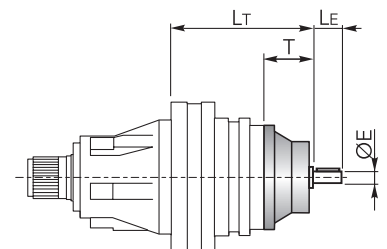



DIMENSIONI · DIMENSIONS

CHPL 18000 CPS - Riduttore a vite senza fine CHM in entrata | CHM input worm gearboxes

CHPL	CHM 50					CHM 63					CHM 75				
	Lv	I	H	M	N	Lv	I	H	M	N	Lv	I	H	M	N
18002	-					-					-				
18003	426	50	110	60	80	435.5	63	135	72	95	414.5	75	161	86	112.5
18004	470					479.5					458.5				

CHPL	CHM 90					CHM 110					CHM 130					
	Lv	I	H	M	N	Lv	I	H	M	N	Lv	I	H	M	N	
18002	-					379	110	237.5	127.5	160	386	130	277.5	147.5	180	
18003	424.5	90	193	103	129.5	452					459					
18004	468.5					-					-					

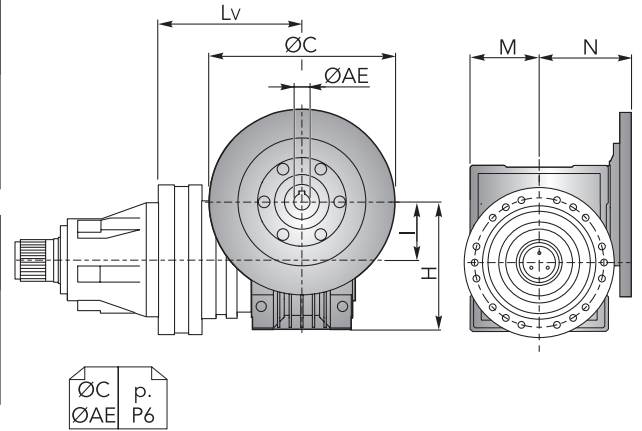

CHPL / CHPLB 18000 CPS

CHPLB 18000 CPS - Flange motori IEC | IEC Motor flanges

CHPLB	IEC 63				IEC 71				IEC 80				IEC 90			
	L	LP	P	ØD	L	LP	P	ØD	L	LP	P	ØD	L	LP	P	ØD
18002	-				-				-				-			
18003	333	276	36	140	333	276	36	160	333	296	56	200	333	296	56	200
18004	406				406				406				406			

CHPLB	IEC 100				IEC 112				IEC 132				IEC 160				IEC 180					
	L	LP	P	ØD	L	LP	P	ØD	L	LP	P	ØD	L	LP	P	ØD	L	LP	P	ØD		
18002	-				-				-				276	433	118	350	276	433	118	350		
18003	333	306	66	250	333	306	66	250	333	340	100	300	333	379	139	350						
18004	406				406				406				406									

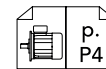
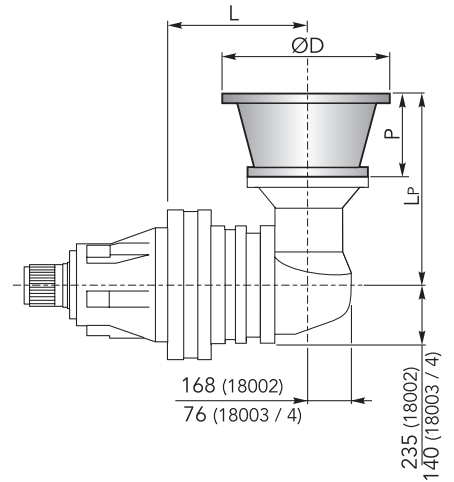

CHPLB 18000 CPS - Alberi maschi entrata | Male input shafts

CHPLB	CM42					CM65					CP65					
	L	Lt	T	Le	ØE	L	Lt	T	Le	ØE	L	Lt	T	Le	ØE	
18002	-					276	436.5				276	468				
18003	333	333	93	82	42 h6	333	377.5	121.5	105	65 h6	333	409	153	105	65 h6	
18004	406					406					406					

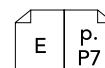
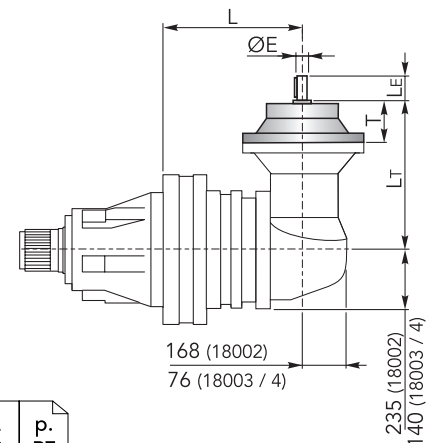

DIMENSIONI · DIMENSIONS

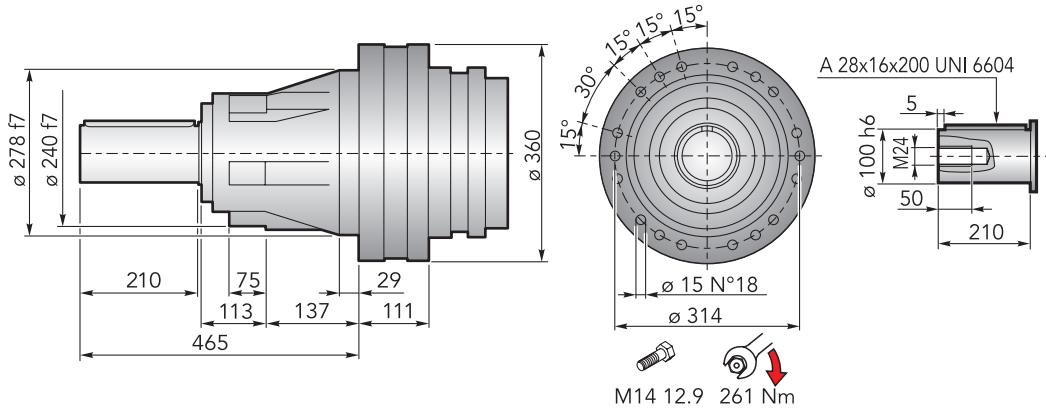

CHPL 18000 CPC - Flange motori IEC | IEC Motor flanges

CHPL	IEC 63			IEC 71			IEC 80			IEC 90			IEC 100		
	LP	P	ØD	LP	P	ØD	LP	P	ØD	LP	P	ØD	LP	P	ØD
18002	-	-	-	-	-	-	-	-	-	-	-	-	-	-	-
18003	336.5	36	140	336.5	36	160	356.5	56	200	356.5	56	200	366.5	66	250
18004	380.5	36	140	380.5	36	160	400.5	56	200	400.5	56	200	410.5	66	250

CHPL	IEC 112			IEC 132			IEC 160			IEC 180		
	LP	P	ØD	LP	P	ØD	LP	P	ØD	LP	P	ØD
18002	-	-	-	-	-	-	359	118	350	359	118	350
18003	366.5	66	250	400.5	100	300	439.5	139	-	-	-	-
18004	410.5	66	250	444.5	100	300	483.5	139	-	-	-	-

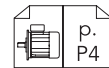
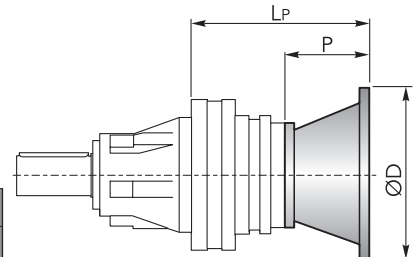

CHPL 18000 CPC - Alberi maschi entrata | Male input shafts

CHPL	CM42				CM65				CP65			
	LT	T	LE	ØE	LT	T	LE	ØE	LT	T	LE	ØE
18002	-	-	-	-	362.5	121.5	105	65 h6	394	153	105	65 h6
18003	393.5	93	82	42 h6	435.5	121.5	105	65 h6	467	153	105	65 h6
18004	437.5	93	82	42 h6	-	-	-	-	-	-	-	-

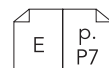
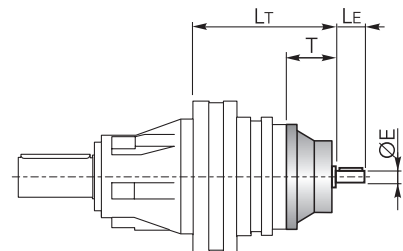



DIMENSIONI · DIMENSIONS

CHPL 18000 CPC - Riduttore a vite senza fine CHM in entrata | *CHM input worm gearboxes*

CHPL	CHM 50					CHM 63					CHM 75				
	Lv	I	H	M	N	Lv	I	H	M	N	Lv	I	H	M	N
18002	-					-					-				
18003	426	50	110	60	80	435.5	63	135	72	95	414.5	75	161	86	112.5
18004	470					479.5					458.5				

CHPL	CHM 90					CHM 110					CHM 130				
	Lv	I	H	M	N	Lv	I	H	M	N	Lv	I	H	M	N
18002	-					379	110	237.5	127.5	160	386	130	277.5	147.5	180
18003	424.5	90	193	103	129.5	452					459				
18004	468.5														

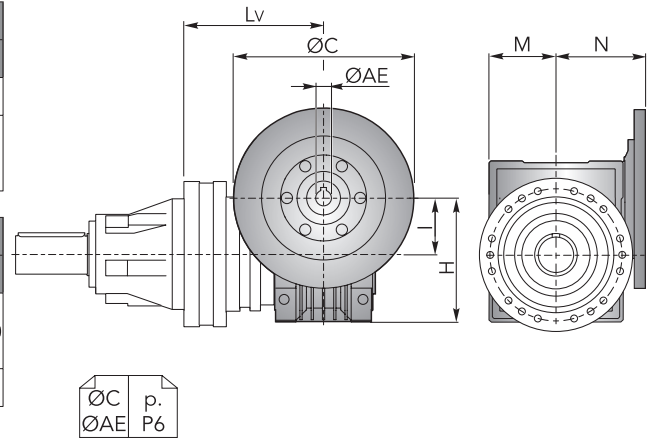

CHPL / CHPLB 18000 CPC

CHPLB 18000 CPC - Flange motori IEC | *IEC Motor flanges*

CHPLB	IEC 63				IEC 71				IEC 80				IEC 90			
	L	LP	P	ØD	L	LP	P	ØD	L	LP	P	ØD	L	LP	P	ØD
18002	-				-				-				-			
18003	333	276	36	140	333	276	36	160	333	296	56	200	333	296	56	200
18004	406				406				406				406			

CHPLB	IEC 100				IEC 112				IEC 132				IEC 160				IEC 180			
	L	LP	P	ØD	L	LP	P	ØD	L	LP	P	ØD	L	LP	P	ØD	L	LP	P	ØD
18002	-				-				-				276	433	118	350	276	433	118	350
18003	333	306	66	250	333	306	66	250	333	340	100	300	333	379	139	350				
18004	406				406				406				406							

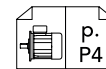
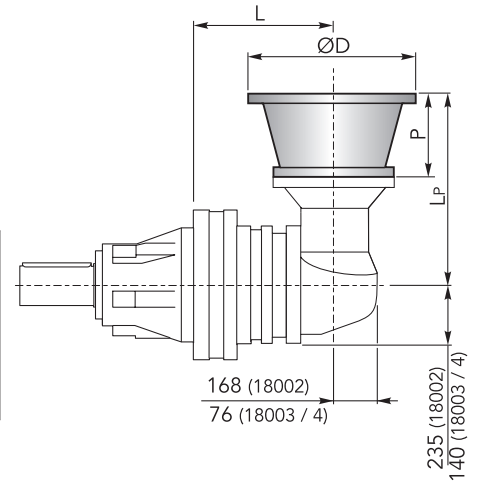

CHPLB 18000 CPC - Alberi maschi entrata | *Male input shafts*

CHPLB	CM42					CM65					CP65					
	L	Lt	T	Le	ØE	L	Lt	T	Le	ØE	L	Lt	T	Le	ØE	
18002	-					276	436.5				276	468				
18003	333	333	93	82	42 h6	333	377.5	121.5	105	65 h6	333	409	153	105	65 h6	
18004	406					406					406					

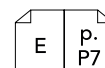
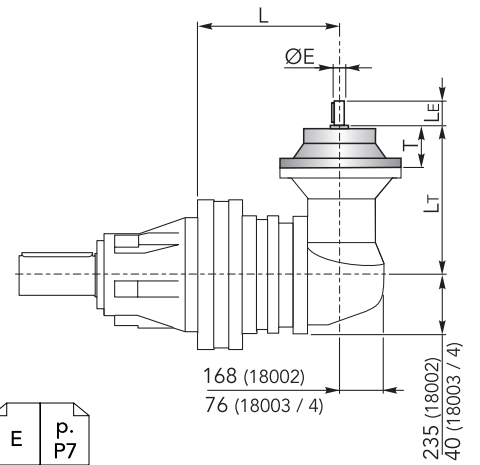



DIMENSIONI · DIMENSIONS

CHPL 18000 CF - Riduttore a vite senza fine CHM in entrata | CHM input worm gearboxes

CHPL	CHM 50					CHM 63					CHM 75				
	Lv	I	H	M	N	Lv	I	H	M	N	Lv	I	H	M	N
18002	-					-					-				
18003	416	50	110	60	80	425.5	63	135	72	95	404.5	75	161	86	112.5
18004	460					469.5					448.5				

CHPL	CHM 90					CHM 110					CHM 130				
	Lv	I	H	M	N	Lv	I	H	M	N	Lv	I	H	M	N
18002	-					369	110	237.5	127.5	160	376	130	277.5	147.5	180
18003	414.5	90	193	103	129.5	442					449				
18004	458.5														

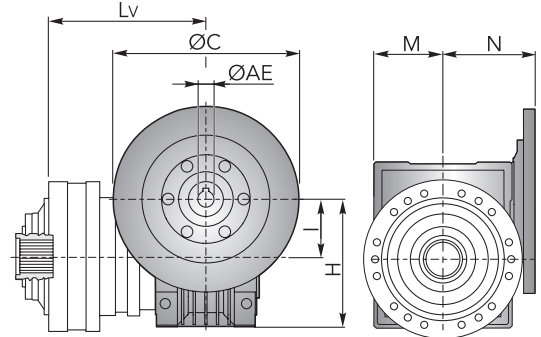

CHPL / CHPLB 18000 CF

CHPLB 18000 CF - Flange motori IEC | IEC Motor flanges

CHPLB	IEC 63				IEC 71				IEC 80				IEC 90			
	L	LP	P	ØD	L	LP	P	ØD	L	LP	P	ØD	L	LP	P	ØD
18002	-				-				-				-			
18003	323	276	36	140	323	276	36	160	323	296	56	200	323	296	56	200
18004	396				396				396				396			

CHPLB	IEC 100				IEC 112				IEC 132				IEC 160				IEC 180			
	L	LP	P	ØD	L	LP	P	ØD	L	LP	P	ØD	L	LP	P	ØD	L	LP	P	ØD
18002	-				-				-				266	433	118	350	266	433	118	350
18003	323	306	66	250	323	306	66	250	323	340	100	300	323	379	139	350				
18004	396				396				396				396							

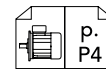
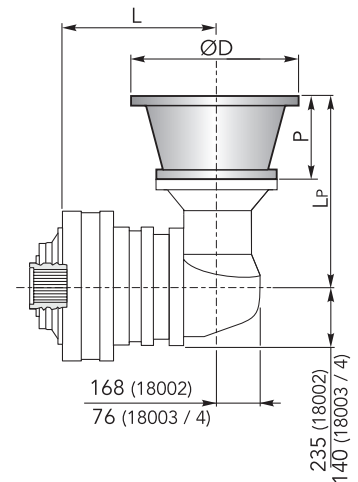

CHPLB 18000 CF - Alberi maschi entrata | Male input shafts

CHPLB	CM42					CM65					CP65					
	L	Lt	T	Le	ØE	L	Lt	T	Le	ØE	L	Lt	T	Le	ØE	
18002	-					266	436.5				266	468				
18003	323	333	93	82	42 h6	323	377.5	121.5	105	65 h6	323	409	153	105	65 h6	
18004	396					396					396					

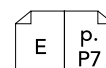
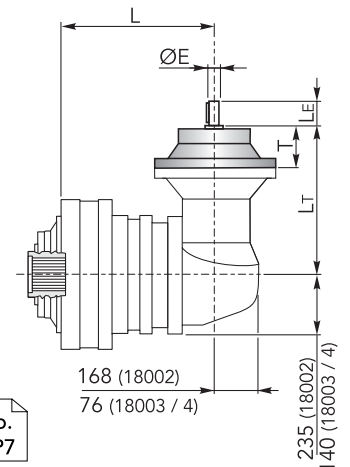

DIMENSIONI · DIMENSIONS

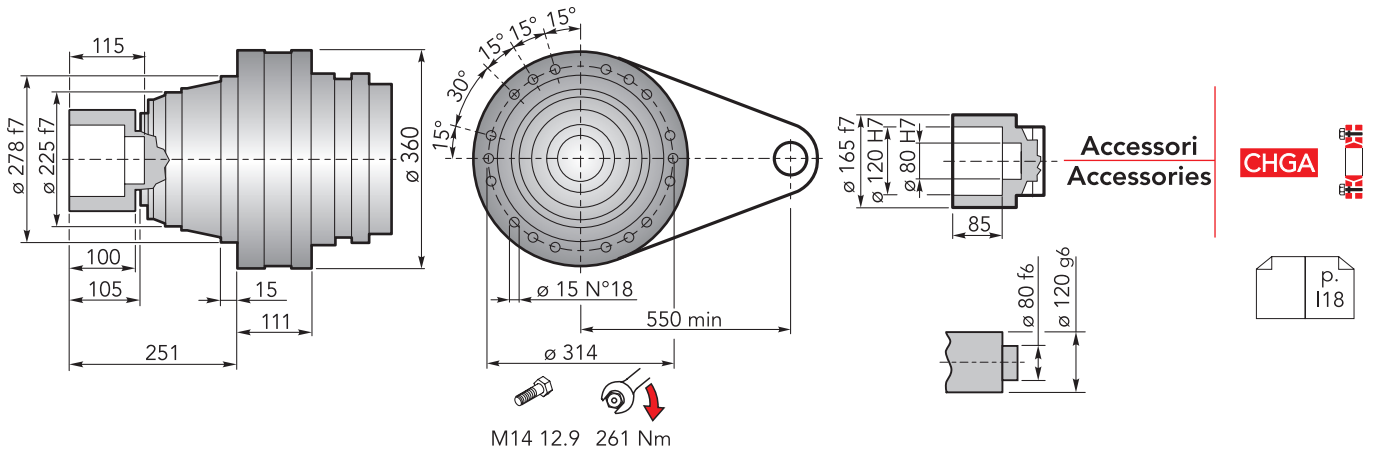

CHPL 18000 CFS - Flange motori IEC | IEC Motor flanges

CHPL	IEC 63			IEC 71			IEC 80			IEC 90			IEC 100		
	LP	P	ØD	LP	P	ØD	LP	P	ØD	LP	P	ØD	LP	P	ØD
18002	-			-			-			-			-		
18003	336.5	36	140	336.5	36	160	356.5	56	200	356.5	56	200	366.5	66	250
18004	380.5			380.5			400.5			400.5			410.5		

CHPL	IEC 112			IEC 132			IEC 160			IEC 180		
	LP	P	ØD	LP	P	ØD	LP	P	ØD	LP	P	ØD
18002	-			-			359	118	350	359	118	350
18003	366.5			400.5	100	300	439.5					
18004	410.5	66	250	444.5			483.5	139				

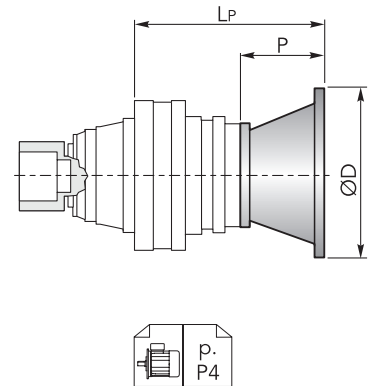

CHPL 18000 CFS - Alberi maschi entrata | Male input shafts

CHPL	CM42				CM65				CP65			
	LT	T	LE	ØE	LT	T	LE	ØE	LT	T	LE	ØE
18002	-				362.5	121.5	105	65 h6	394	153	105	65 h6
18003	393.5	93	82	42 h6	435.5				467			
18004	437.5											

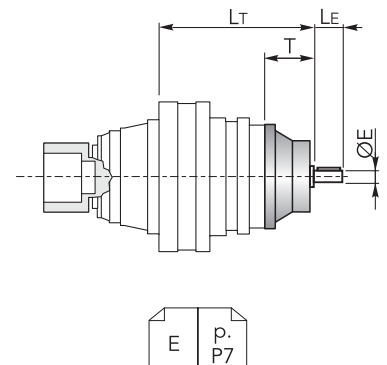



DIMENSIONI · DIMENSIONS

CHPL 18000 CFS - Riduttore a vite senza fine CHM in entrata | CHM input worm gearboxes

CHPL	CHM 50					CHM 63					CHM 75				
	Lv	I	H	M	N	Lv	I	H	M	N	Lv	I	H	M	N
18002	-					-					-				
18003	426	50	110	60	80	435.5	63	135	72	95	414.5	75	161	86	112.5
18004	470					479.5					458.5				

CHPL	CHM 90					CHM 110					CHM 130					
	Lv	I	H	M	N	Lv	I	H	M	N	Lv	I	H	M	N	
18002	-					379	110	237.5	127.5	160	386	130	277.5	147.5	180	
18003	424.5	90	193	103	129.5	452					459					
18004	468.5															

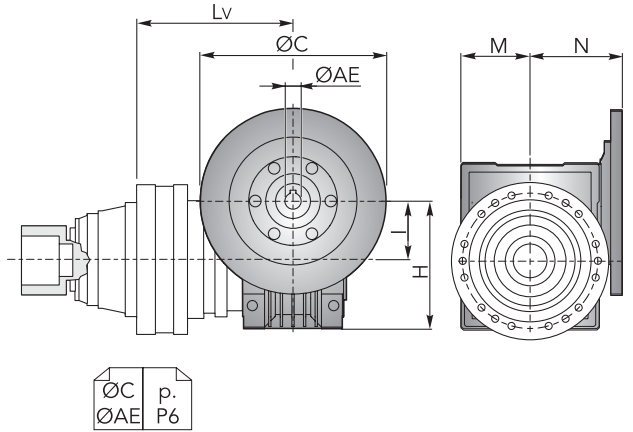

CHPL / CHPLB 18000 CFS

CHPLB 18000 CFS - Flange motori IEC | IEC Motor flanges

CHPLB	IEC 63				IEC 71				IEC 80				IEC 90			
	L	LP	P	ØD	L	LP	P	ØD	L	LP	P	ØD	L	LP	P	ØD
18002	-				-				-				-			
18003	333	276	36	140	333	276	36	160	333	296	56	200	333	296	56	200
18004	406				406				406				406			

CHPLB	IEC 100				IEC 112				IEC 132				IEC 160				IEC 180					
	L	LP	P	ØD	L	LP	P	ØD	L	LP	P	ØD	L	LP	P	ØD	L	LP	P	ØD		
18002	-				-				-				276	433	118	350	276	433	118	350		
18003	333	306	66	250	333	306	66	250	333	340	100	300	333	379	139	350						
18004	406				406				406				406									

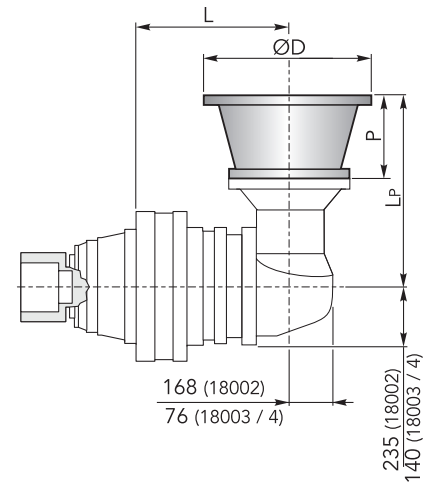

CHPLB 18000 CFS - Alberi maschi entrata | Male input shafts

CHPLB	CM42					CM65					CP65					
	L	Lt	T	Le	ØE	L	Lt	T	Le	ØE	L	Lt	T	Le	ØE	
18002	-					276	436.5				276	468				
18003	333	333	93	82	42 h6	333	377.5	121.5	105	65 h6	333	409	153	105	65 h6	
18004	406					406					406					

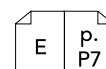
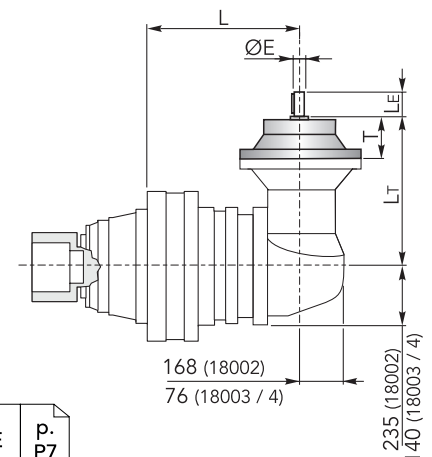
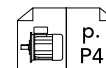

DIMENSIONI · DIMENSIONS

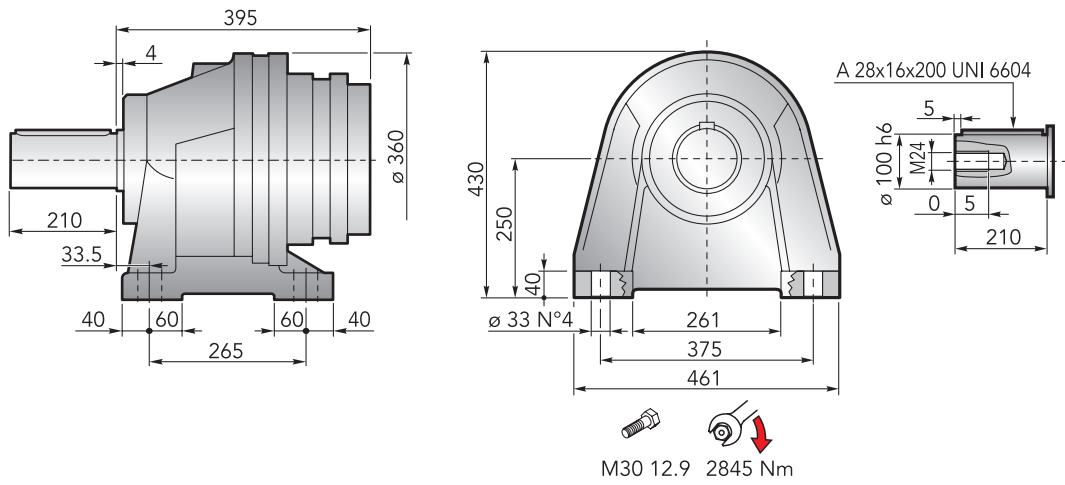

CHPL 18000 CCPC - Flange motori IEC | IEC Motor flanges

CHPL	IEC 63			IEC 71			IEC 80			IEC 90			IEC 100		
	LP	P	ØD	LP	P	ØD	LP	P	ØD	LP	P	ØD	LP	P	ØD
18002	-	-	-	-	-	-	-	-	-	-	-	-	-	-	-
18003	490.5	36	140	490.5	36	160	510.5	56	200	510.5	56	200	520.5	66	250
18004	538.5	-	-	538.5	-	-	558.5	-	-	558.5	-	-	568.5	-	-

CHPL	IEC 112			IEC 132			IEC 160			IEC 180		
	LP	P	ØD	LP	P	ØD	LP	P	ØD	LP	P	ØD
18002	-	-	-	-	-	-	513	118	350	513	118	350
18003	520.5	66	250	554.5	100	300	593.5	139	-	-	-	-
18004	568.5	-	-	602.5	-	-	641.5	-	-	-	-	-

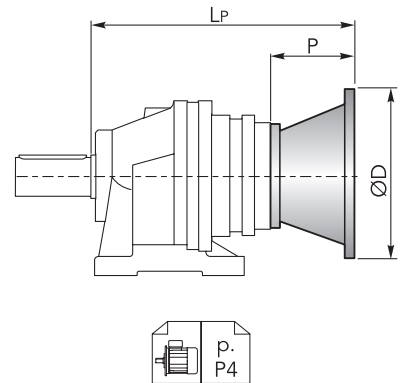

CHPL 18000 CCPC - Alberi maschi entrata | Male input shafts

CHPL	CM42				CM65				CP65			
	LT	T	LE	ØE	LT	T	LE	ØE	LT	T	LE	ØE
18002	-	-	-	-	516.5	121.5	105	65 h6	548	153	105	65 h6
18003	547.5	93	82	42 h6	589.5	-	-	-	621	-	-	-
18004	595.5	-	-	-	-	-	-	-	-	-	-	-

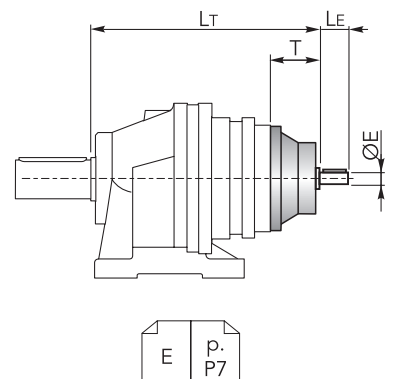



DIMENSIONI · DIMENSIONS

CHPL 18000 CCPC - Riduttore a vite senza fine CHM in entrata | *CHM input worm gearboxes*

CHPL	CHM 50					CHM 63					CHM 75				
	Lv	I	H	M	N	Lv	I	H	M	N	Lv	I	H	M	N
18002	-					-					-				
18003	580	50	110	60	80	589.5	63	135	72	95	568.5	75	161	86	112.5
18004	628					637.5					616.5				

CHPL	CHM 90					CHM 110					CHM 130					
	Lv	I	H	M	N	Lv	I	H	M	N	Lv	I	H	M	N	
18002	-					533	110	237.5	127.5	160	540	130	277.5	147.5	180	
18003	578.5	90	193	103	129.5	606					613					
18004	626.5															

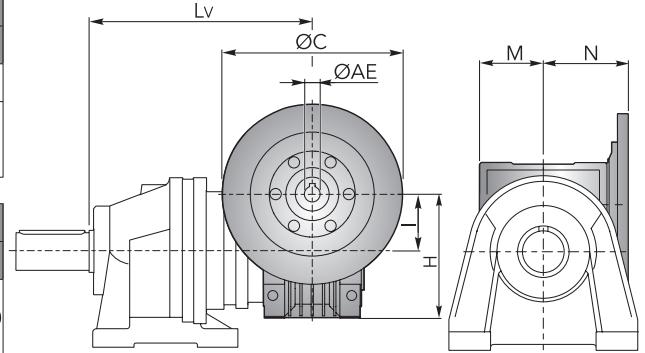

CHPL / CHPLB 18000 CCPC

CHPLB 18000 CCPC - Flange motori IEC | *IEC Motor flanges*

CHPLB	IEC 63				IEC 71				IEC 80				IEC 90			
	L	LP	P	ØD	L	LP	P	ØD	L	LP	P	ØD	L	LP	P	ØD
18002	-				-				-				-			
18003	483	276	36	140	483	276	36	160	483	296	56	200	483	296	56	200
18004	542.5				542.5				542.5				542.5			

CHPLB	IEC 100				IEC 112				IEC 132				IEC 160				IEC 180					
	L	LP	P	ØD	L	LP	P	ØD	L	LP	P	ØD	L	LP	P	ØD	L	LP	P	ØD		
18002	-				-				-				430	433	118		430	433	118	350		
18003	483	306	66	250	483	306	66	250	483	340	100	300	483	379	139	350						
18004	542.5				542.5				542.5				542.5									

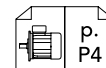
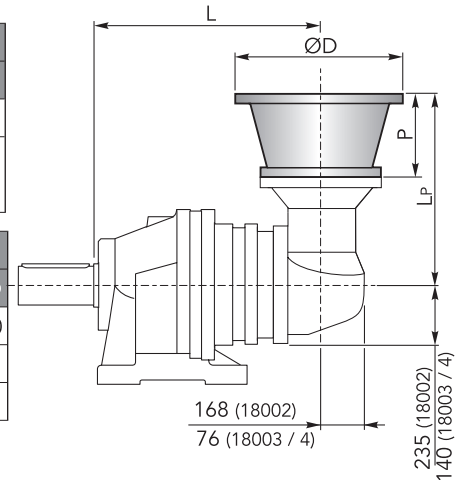

CHPLB 18000 CCPC - Alberi maschi entrata | *Male input shafts*

CHPLB	CM42					CM65					CP65					
	L	Lt	T	Le	ØE	L	Lt	T	Le	ØE	L	Lt	T	Le	ØE	
18002	-					430	436.5				430	468				
18003	483	333	93	82	42 h6	483	377.5	121.5	105	65 h6	483	409	153	105	65 h6	
18004	542.5					542.5					542.5					

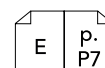
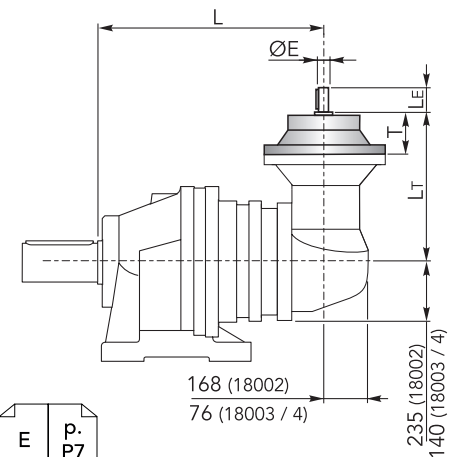

ACCESSORI · ACCESSORIES

CHYZ



Pignoni | Pinions

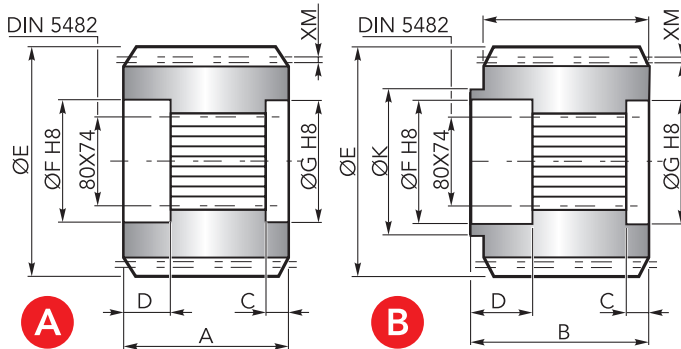

	Uscita / Output	M	Z	XM	A	B	C	D	E	F	G	K	Codice / Code
A	CMS	10	12	0	90	-	10	31	140	85	80	-	1071.236.042
	CMS	10	14	0	90	-	10	31	160	85	80	-	1071.238.042
	CMS	10	15	5	90	-	10	31	180	85	80	-	1071.138.042
B	CMS	10	18	5	85	114	31	24	209.3	85	95	160	1071.261.042
	CMS	12	14	3	90	105	15	31	194.5	85	95	130	1071.269.042

CHFF



Fondello di arresto | Stop bottom plate

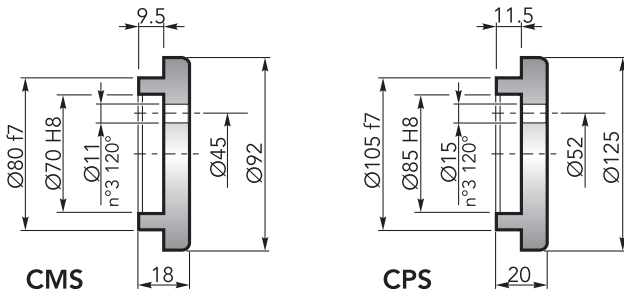

CMS

Codice / Code:
1075.030.000

CPS

Codice / Code:
1075.042.000

CHBS



Boccola scanalata | Splined bushing

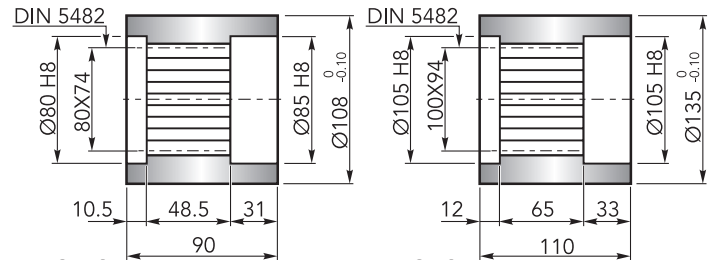

CMS

Codice / Code:
6171.103.076

CPS

Codice / Code:
8171.112.041

CHKB

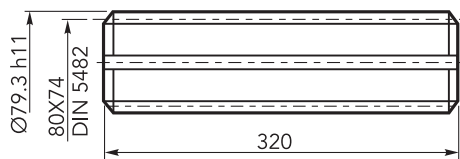

Barra scanalata | Splined rod

Codice / Code:
3071.406.042

CHGA

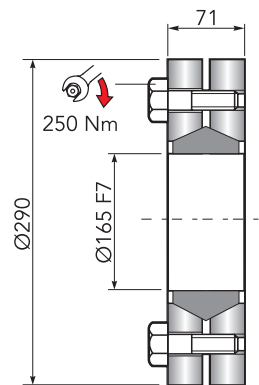

Giunto di attrito | Shrink disc

Codice / Code:
5109.165.000Coppia max: 35000 Nm⁽¹⁾
Max Torque: 35000 Nm⁽¹⁾

CHFL



Flangia | Flange

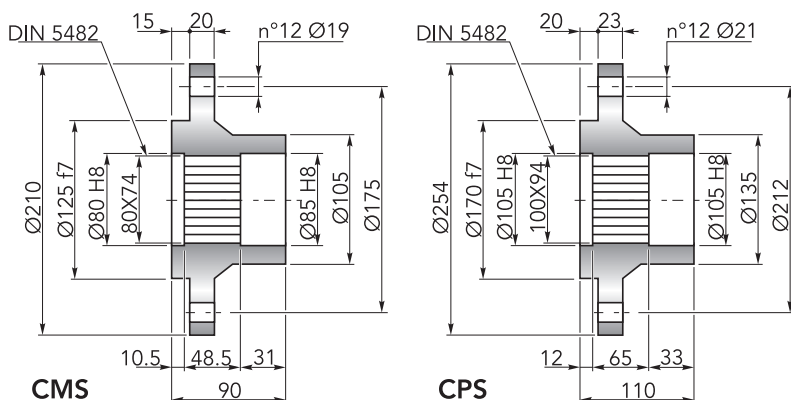

CMS

Codice / Code:
6171.105.098

CPS

Codice / Code:
8171.104.098

(1): Coppia max indicata è valida solo con calettatori forniti da Chiaravalli S.p.A.

(1): The maximum torque indicated is valid only with shrink discs supplied by Chiaravalli S.p.A.



CARICHI RADIALI (Fr) · RADIAL LOADS (Fr)

Nel diagramma seguente, sono indicati i carichi radiali F_r (N) applicabili sull'albero uscita in funzione della distanza di applicazione L rispetto alla battuta dell'albero.

The hereunder table shows the allowable radial loads F_r (N) on the output shaft with reference to the distance L .

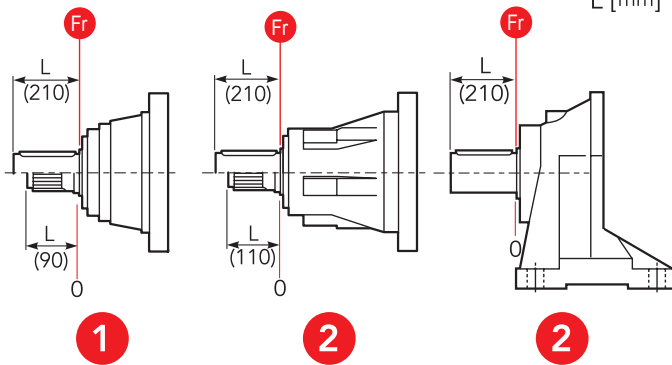
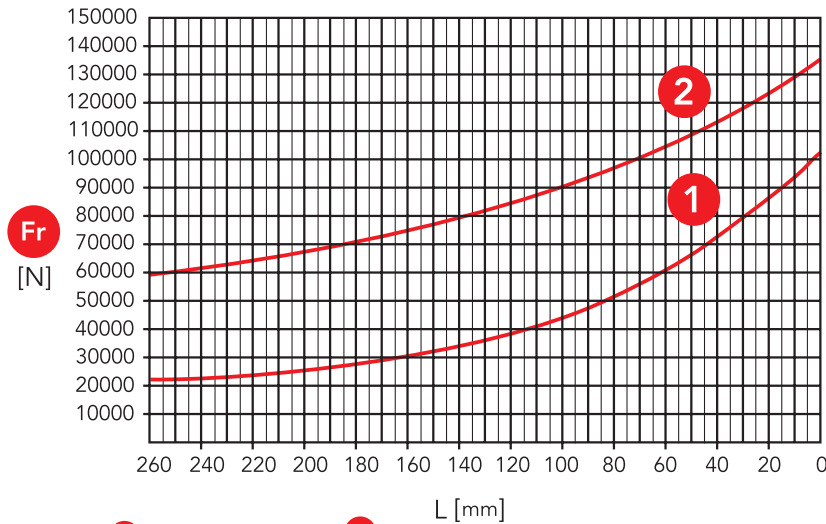

- 1** Uscita / Output: CMS, CMC
- 2** Uscita / Output: CPS, CPC, CCPC

CARICHI ASSIALI (Fa) · AXIAL LOADS (Fa)

Nella tabella seguente sono indicati i carichi assiali F_a (N) applicabili sull'albero di uscita in funzione della direzione di applicazione del carico e della versione.

The hereunder table shows the allowable axial loads F_a (N) on the output shaft with reference to the load direction and the output type.

	1	2	
F_a [N]	45000	85000	←
	65000	85000	→

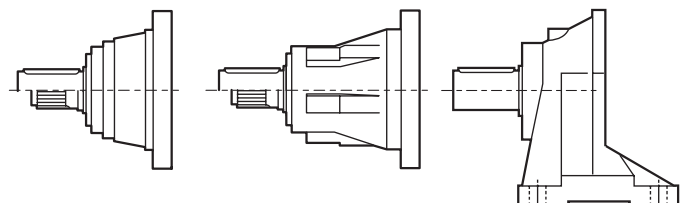

- 1** Uscita / Output: CMS, CMC
- 2** Uscita / Output: CPS, CPC, CCPC

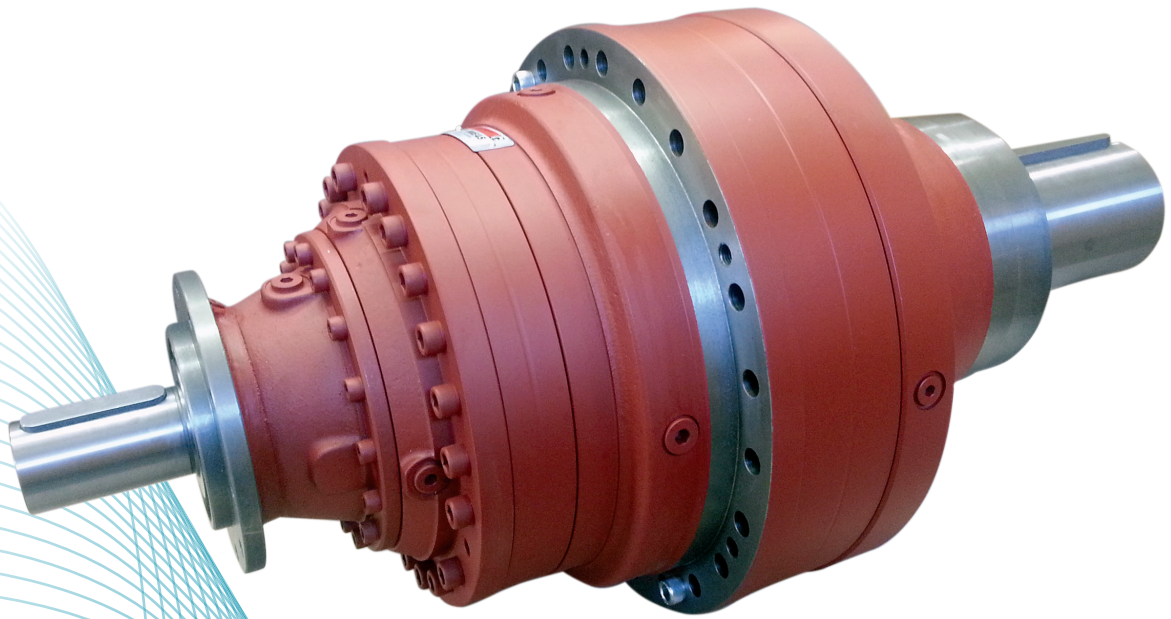



CHPL

	<i>i</i>	
25001	4.00 ÷ 6.25	1 reduction stage
25002	14.7 ÷ 43.8	2 reduction stages
25003	55.4 ÷ 317.2	3 reduction stages
25004	338.8 ÷ 1774.0	4 reduction stages

OUT

IN

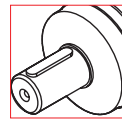

Ø110

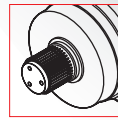

100x94
DIN 5482

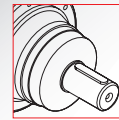

Ø42
Ø65

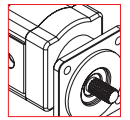

Hydraulic
Motor

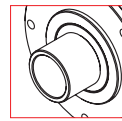

Ø135

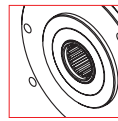

100x94
DIN 5482

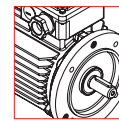

Electric
Motor

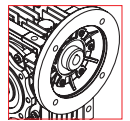

Worm
gearboxes

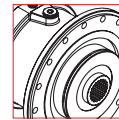

Brake

CHPLB

	<i>i</i>	
25002	12.3 ÷ 29.2	2 reduction stages
25003	50.7 ÷ 238.2	3 reduction stages
25004	252.4 ÷ 1726.9	4 reduction stages

OUT

IN

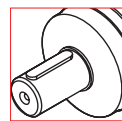

Ø110

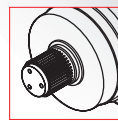

100x94
DIN 5482

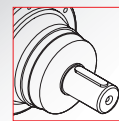

Ø42
Ø65

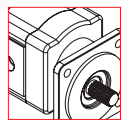

Hydraulic
Motor

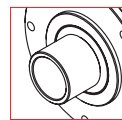

Ø135

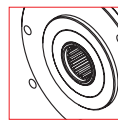

100x94
DIN 5482

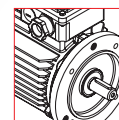

Electric
Motor

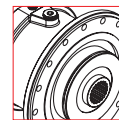

Brake

DATI TECNICI · TECHNICAL DATA

CHPL	i	T _{2n}	P _{1n}	T ₂ Max	P _t	IEC		CHM	CM/CP
		(n ₁ = 1400 rpm) 10.000h FS=1 [Nm]	(n ₁ = 1400 rpm) 10.000h FS=1 [kW]	[Nm]	1400 rpm [kW]	(B5)			
25001	4	13808	522	62760	50	160	180	-	-
	5.2	10675	310	48520		200	225		
	6.25	8517	207	37440		250			
25002	14.7	16808	180	62760	30	160 200	180	CHM 110 CHM 130	CM65 CP65
	17.7	12243	148.5	62760					
	20	17470	137.5	62760					
	23	13662	93.5	48520					
	26	13626	82.5	48520					
	30.2	14772	77	48520					
	36.3	11414	49.5	37440					
	43.8	12243	44	37440					
25003	55.4	20919	61.6	62760	20	63 80 100 132 180	71 90 112 160	CHM 50 CHM 63 CHM 75 CHM 90 CHM 110 CHM 130	CM42 CM65 CP65
	60.5	21214	57.2	62760					
	73.1	21688	48.4	62760					
	88	22658	41.8	62760					
	95	17297	30.8	48520					
	106.3	23458	35.2	62760					
	114.4	18514	26.4	48520					
	128.4	24243	30.8	62760					
	134.3	19018	22	48520					
	156	18934	19.8	48520					
	167	19144	19.8	48520					
	188.5	19065	17.6	48520					
	218.7	20646	15.4	48520					
	226.6	15280	11	37440					
	262.8	15948	9.9	37440					
317.2	17112	8.8	37440						
25004	338.8	27657	13.8	62760	15	63 80 100 132	71 90 112 160	CHM 50 CHM 63 CHM 75 CHM 90	CM42
	374	28496	12.9	62760					
	408.4	28894	12	62760					
	424.3	30020	12	62760					
	455.5	29747	11.1	62760					
	493.2	29526	10.2	62760					
	556.9	30307	9.2	62760					
	617.8	30260	8.3	62760					
	697.5	30368	7.4	62760					
	752.3	24475	5.5	48520					
	803.1	25083	5.3	48520					
	873.6	26149	5.1	48520					
	934.9	25551	4.7	48520					
	1013.4	26376	4.4	48520					
	1126.9	26397	4	48520					
	1272.4	28151	3.8	48520					
	1354.5	21153	2.7	37440					
	1476	28814	3.3	48520					
1529.3	21893	2.5	37440						
1774	23087	2.2	37440						

n_{1max} = 2800 rpm

per ulteriori rapporti consultare l'ufficio tecnico

for information consult the technical office

Solo per / only for CHPL 25001 n_{1max} = 1500 rpm

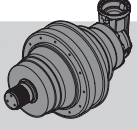
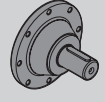

DATI TECNICI · TECHNICAL DATA

 CHPLB	i	T _{2n} (n ₁ = 1400 rpm) 10.000h FS=1 [Nm]	P _{1n} (n ₁ = 1400 rpm) 10.000h FS=1 [kW]	T ₂ Max [Nm]	P _t 1400 rpm [kW]	IEC (B5)	 CM/CP
25002	12.3	15822	202.5	62760	30	160 180 200	CM65 CP65
	16	12959	127.5	48520			
	19.2	10062	82.5	37440			
	24.3	13893	90	48520			
	29.2	11130	60	37440			
25003	50.7	20698	66.6	62760	20	63 71 80 90 100 112 132 160 180	CM42 CM65 CP65
	61.2	20822	55.5	62760			
	69.1	21941	51.8	62760			
	79.6	16249	33.3	48520			
	89.8	18331	33.3	48520			
	96.4	21864	37	62760			
	104.2	18907	29.6	48520			
	125.4	18604	24.2	48520			
	141.6	19096	22	48520			
	164.2	18823	18.7	48520			
	197.4	15974	13.2	37440			
	238.2	16062	11	37440			
	25004	252.4	26279	17.6			
285		27819	16.5	62760			
304		27694	15.4	62760			
364.3		28446	13.2	62760			
397.8		28474	12.1	62760			
449.2		29229	11	62760			
498.3		29182	9.9	62760			
562.6		29287	8.8	62760			
651.2		24578	6.38	48520			
731.4		24747	5.72	48520			
789.4		32221	6.9	62760			
985.2		25642	4.4	48520			
1190.5		26338	3.74	48520			
1430.9		22347	2.64	37440			
1726.9		22474	2.2	37440			

n_{1max} = 2800 rpm

per ulteriori rapporti consultare l'ufficio tecnico

for information consult the technical office

Solo per / only for CHPLB 25002 n_{1max} = 2000 rpm

CHPLB 25000

DIMENSIONI · DIMENSIONS

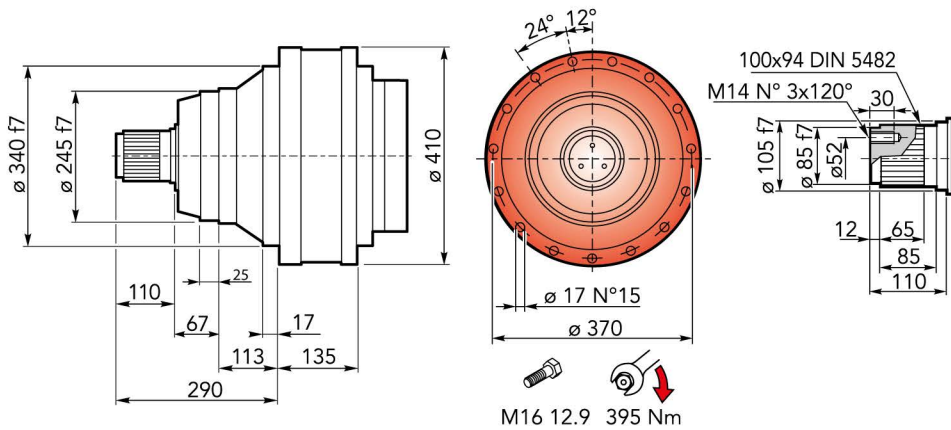

CHPL 25000 CMS - Flange motori IEC | IEC Motor flanges

CHPL	IEC 63			IEC 71			IEC 80			IEC 90			IEC 100			IEC 112		
	LP	P	ØD	LP	P	ØD	LP	P	ØD	LP	P	ØD	LP	P	ØD	LP	P	ØD
25001	-	-	-	-	-	-	-	-	-	-	-	-	-	-	-	-	-	-
25002	-	-	-	-	-	-	-	-	-	-	-	-	-	-	-	-	-	-
25003	419.5	36	140	419.5	36	160	439.5	56	200	439.5	56	200	449.5	66	250	449.5	66	250
25004	467.5	-	-	467.5	-	-	487.5	-	-	487.5	-	-	497.5	-	-	497.5	-	-

CHPL	IEC 132			IEC 160			IEC 180			IEC 200			IEC 225			IEC 250		
	LP	P	ØD	LP	P	ØD	LP	P	ØD	LP	P	ØD	LP	P	ØD	LP	P	ØD
25001	-	-	-	380	150	-	380	150	-	380	150	400	369	139	450	369	139	550
25002	-	-	-	442	118	350	442	118	350	472	148	400	-	-	-	-	-	-
25003	483.5	100	300	522.5	139	350	522.5	139	350	-	-	-	-	-	-	-	-	-
25004	531.5	-	-	570.5	-	-	-	-	-	-	-	-	-	-	-	-	-	-

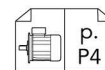
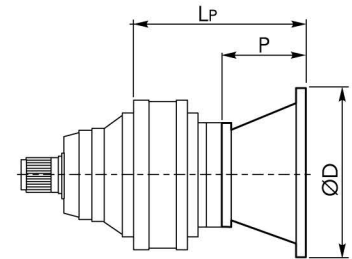

CHPL 25000 CMS - Alberi maschi entrata | Male input shafts

CHPL	CM42				CM65				CP65			
	LT	T	LE	ØE	LT	T	LE	ØE	LT	T	LE	ØE
25001	-	-	-	-	-	-	-	-	-	-	-	-
25002	-	-	-	-	445.5	121.5	105	65 h6	477	153	105	65 h6
25003	476.5	93	82	42 h6	518.5	-	-	-	550	-	-	-
25004	524.5	-	-	-	-	-	-	-	-	-	-	-

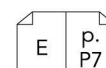
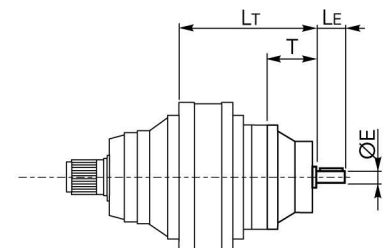



DIMENSIONI · DIMENSIONS

CHPL 25000 CMS - Riduttore a vite senza fine CHM in entrata | *CHM input worm gearboxes*

CHPL	CHM 50					CHM 63					CHM 75				
	Lv	I	H	M	N	Lv	I	H	M	N	Lv	I	H	M	N
25001	-					-					-				
25002	-					-					-				
25003	509	50	110	60	80	518.5	63	135	72	95	497.5	75	161	86	112.5
25004	557	50	110	60	80	566.5	63	135	72	95	545.5	75	161	86	112.5

CHPL	CHM 90					CHM 110					CHM 130					
	Lv	I	H	M	N	Lv	I	H	M	N	Lv	I	H	M	N	
25001	-					-					-					
25002	-					462	110	237.5	127.5	160	469	130	277.5	147.5	180	
25003	507.5	90	193	103	129.5	535	110	237.5	127.5	160	542	130	277.5	147.5	180	
25004	555.5	90	193	103	129.5	535	110	237.5	127.5	160	542	130	277.5	147.5	180	

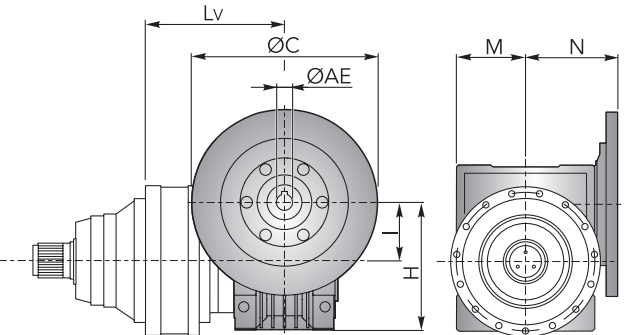

$\varnothing C$ p.
 $\varnothing AE$ P6

CHPLB 25000 CMS - Flange motori IEC | *IEC Motor flanges*

CHPLB	IEC 63				IEC 71				IEC 80				IEC 90				IEC 100			
	L	Lp	P	ØD	L	Lp	P	ØD	L	Lp	P	ØD	L	Lp	P	ØD	L	Lp	P	ØD
25002	-				-				-				-				-			
25003	410	276	36	140	410	276	36	160	410	296	56	200	410	296	56	200	410	306	66	250
25004	483	276	36	140	483	276	36	160	483	296	56	200	483	296	56	200	483	306	66	250

CHPLB	IEC 112				IEC 132				IEC 160				IEC 180				IEC 200			
	L	Lp	P	ØD	L	Lp	P	ØD	L	Lp	P	ØD	L	Lp	P	ØD	L	Lp	P	ØD
25002	-				-				308	433	118	350	308	433	118	350	308	463	148	400
25003	410	306	66	250	410	340	100	300	410	379	139	350	410	379	139	350	-	-	-	-
25004	483	306	66	250	483	340	100	300	483	379	139	350	483	379	139	350	-	-	-	-

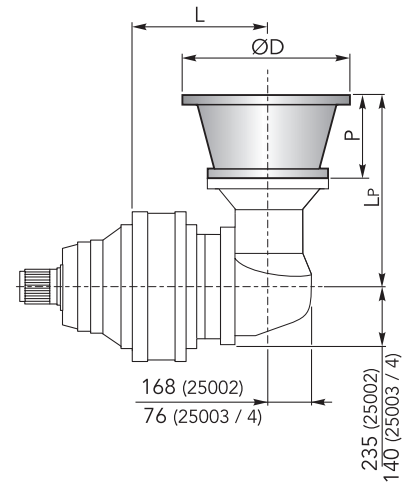

$\varnothing D$ p.
 P4

CHPLB 25000 CMS - Alberi maschi entrata | *Male input shafts*

CHPLB	CM42					CM65					CP65					
	L	Lt	T	Le	ØE	L	Lt	T	Le	ØE	L	Lt	T	Le	ØE	
25002	-					308	436.5	-	-	-	308	468	-	-	-	-
25003	410	333	93	82	42 h6	410	377.5	121.5	105	65 h6	410	409	153	105	65 h6	
25004	483	333	93	82	42 h6	483	377.5	121.5	105	65 h6	483	409	153	105	65 h6	

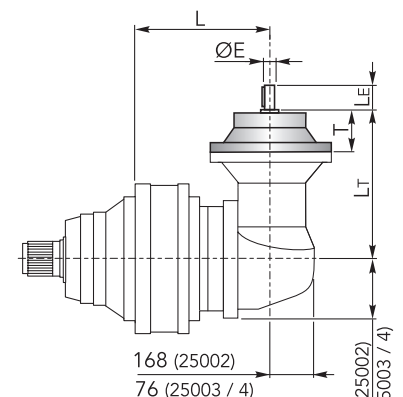

E p.
 P7

DIMENSIONI · DIMENSIONS

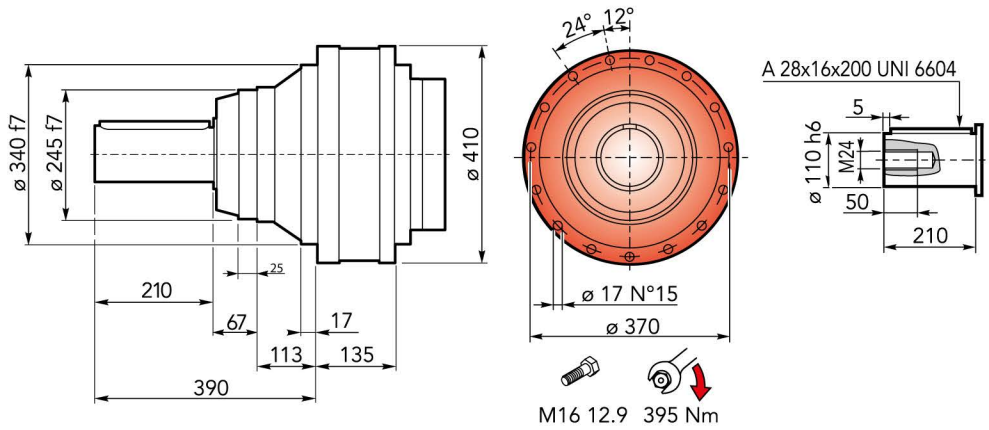

CHPL 25000 CMC - Flange motori IEC | IEC Motor flanges

CHPL	IEC 63			IEC 71			IEC 80			IEC 90			IEC 100			IEC 112		
	LP	P	ØD	LP	P	ØD	LP	P	ØD	LP	P	ØD	LP	P	ØD	LP	P	ØD
25001	-	-	-	-	-	-	-	-	-	-	-	-	-	-	-	-	-	-
25002	-	-	-	-	-	-	-	-	-	-	-	-	-	-	-	-	-	-
25003	419.5	36	140	419.5	36	160	439.5	56	200	439.5	56	200	449.5	66	250	449.5	66	250
25004	467.5	-	-	467.5	-	-	487.5	-	-	487.5	-	-	497.5	-	-	497.5	-	-

CHPL	IEC 132			IEC 160			IEC 180			IEC 200			IEC 225			IEC 250		
	LP	P	ØD	LP	P	ØD	LP	P	ØD	LP	P	ØD	LP	P	ØD	LP	P	ØD
25001	-	-	-	380	150	-	380	150	-	380	150	400	369	139	450	369	139	550
25002	-	-	-	442	118	350	442	118	350	472	148	-	-	-	-	-	-	-
25003	483.5	100	300	522.5	139	-	522.5	139	-	-	-	-	-	-	-	-	-	-
25004	531.5	-	-	570.5	-	-	-	-	-	-	-	-	-	-	-	-	-	-

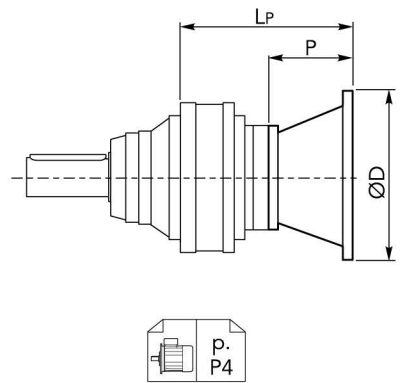

CHPL 25000 CMC - Alberi maschi entrata | Male input shafts

CHPL	CM42				CM65				CP65			
	LT	T	LE	ØE	LT	T	LE	ØE	LT	T	LE	ØE
25001	-	-	-	-	-	-	-	-	-	-	-	-
25002	-	-	-	-	445.5	121.5	105	65 h6	477	153	105	65 h6
25003	476.5	93	82	42 h6	518.5	-	-	-	550	-	-	-
25004	524.5	-	-	-	-	-	-	-	-	-	-	-

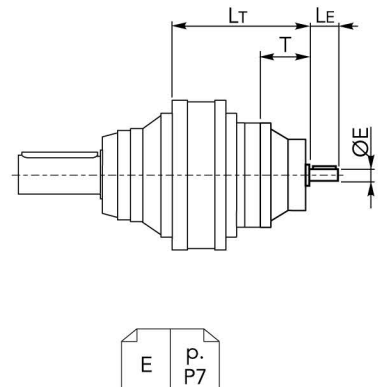



DIMENSIONI · DIMENSIONS

CHPL 25000 CMC - Riduttore a vite senza fine CHM in entrata | *CHM input worm gearboxes*

CHPL	CHM 50					CHM 63					CHM 75				
	Lv	I	H	M	N	Lv	I	H	M	N	Lv	I	H	M	N
25001	-					-					-				
25002	-					-					-				
25003	509	50	110	60	80	518.5	63	135	72	95	497.5	75	161	86	112.5
25004	557	50	110	60	80	566.5	63	135	72	95	545.5	75	161	86	112.5

CHPL	CHM 90					CHM 110					CHM 130					
	Lv	I	H	M	N	Lv	I	H	M	N	Lv	I	H	M	N	
25001	-					-					-					
25002	-					462	110	237.5	127.5	160	469	130	277.5	147.5	180	
25003	507.5	90	193	103	129.5	535					542					
25004	555.5	90	193	103	129.5											

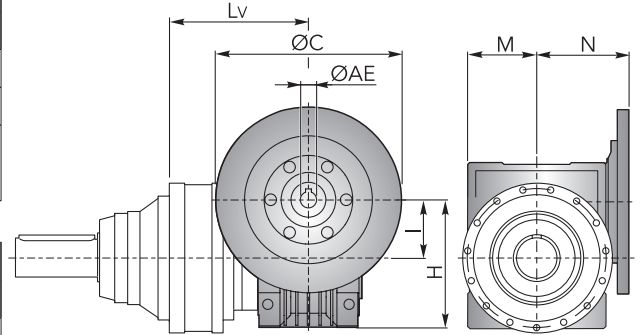

CHPL / CHPLB 25000 CMC

CHPLB 25000 CMC - Flange motori IEC | *IEC Motor flanges*

CHPLB	IEC 63				IEC 71				IEC 80				IEC 90				IEC 100			
	L	Lp	P	ØD	L	Lp	P	ØD	L	Lp	P	ØD	L	Lp	P	ØD	L	Lp	P	ØD
25002	-				-				-				-				-			
25003	410	276	36	140	410	276	36	160	410	296	56	200	410	296	56	200	410	306	66	250
25004	483	276	36	140	483	276	36	160	483	296	56	200	483	296	56	200	483	306	66	250

CHPLB	IEC 112				IEC 132				IEC 160				IEC 180				IEC 200			
	L	Lp	P	ØD	L	Lp	P	ØD	L	Lp	P	ØD	L	Lp	P	ØD	L	Lp	P	ØD
25002	-				-				308	433	118		308	433	118		308	463	148	400
25003	410	306	66	250	410	340	100	300	410	379	139	350	410	379	139	350				
25004	483	306	66	250	483	340	100	300	483	379	139	350								

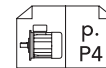
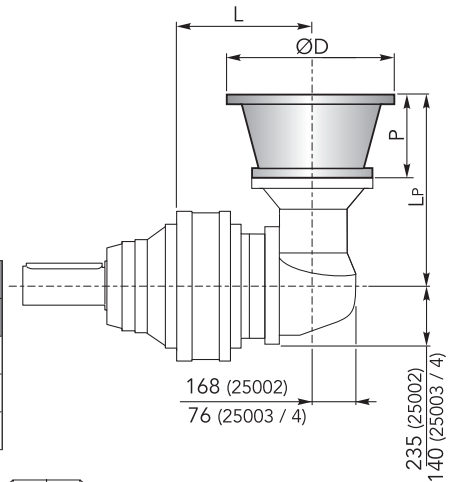

CHPLB 25000 CMC - Alberi maschi entrata | *Male input shafts*

CHPLB	CM42					CM65					CP65					
	L	Lt	T	Le	ØE	L	Lt	T	Le	ØE	L	Lt	T	Le	ØE	
25002	-					308	436.5				308	468				
25003	410	333	93	82	42 h6	410	377.5	121.5	105	65 h6	410	409	153	105	65 h6	
25004	483	333	93	82	42 h6	483	377.5	121.5	105	65 h6	483	409	153	105	65 h6	

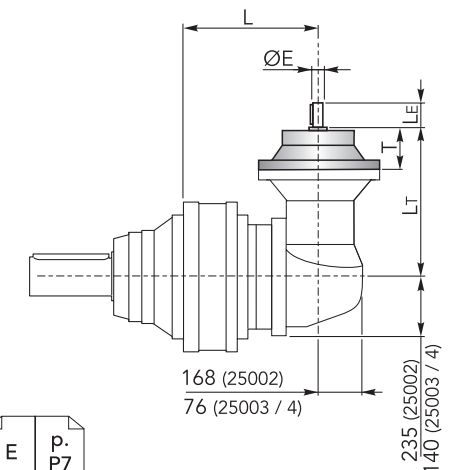

DIMENSIONI · DIMENSIONS

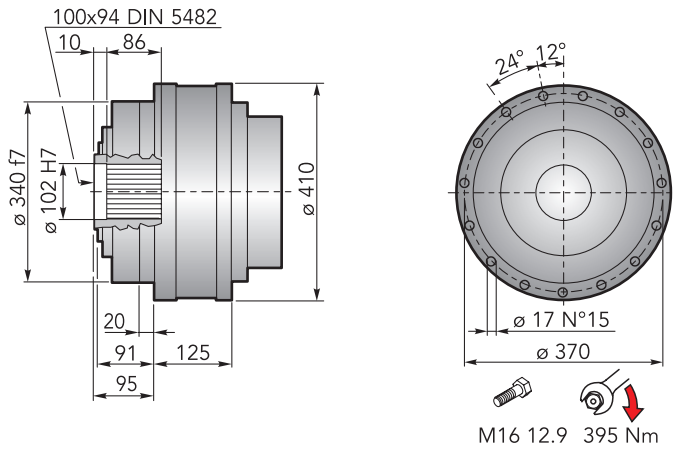

Accessori
Accessories

CHKB



CHPL 25000 CF - Flange motori IEC | IEC Motor flanges

CHPL	IEC 63			IEC 71			IEC 80			IEC 90			IEC 100			IEC 112		
	LP	P	ØD	LP	P	ØD	LP	P	ØD	LP	P	ØD	LP	P	ØD	LP	P	ØD
25001	-	-	-	-	-	-	-	-	-	-	-	-	-	-	-	-	-	-
25002	-	-	-	-	-	-	-	-	-	-	-	-	-	-	-	-	-	-
25003	409.5	36	140	409.5	36	160	429.5	56	200	429.5	56	200	439.5	66	250	439.5	66	250
25004	457.5	-	-	457.5	-	-	477.5	-	-	477.5	-	-	487.5	-	-	487.5	-	-

CHPL	IEC 132			IEC 160			IEC 180			IEC 200			IEC 225			IEC 250		
	LP	P	ØD	LP	P	ØD	LP	P	ØD	LP	P	ØD	LP	P	ØD	LP	P	ØD
25001	-	-	-	370	150	-	370	150	-	370	150	400	359	139	450	359	139	550
25002	-	-	-	432	118	-	432	118	350	462	148	-	-	-	-	-	-	-
25003	473.5	-	-	512.5	-	350	512.5	139	-	-	-	-	-	-	-	-	-	-
25004	521.5	100	300	560.5	139	-	-	-	-	-	-	-	-	-	-	-	-	-

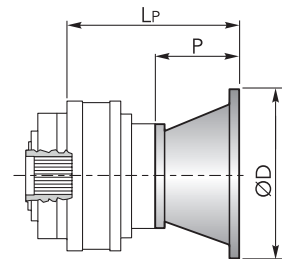

CHPL 25000 CF - Alberi maschi entrata | Male input shafts

CHPL	CM42				CM65				CP65			
	LT	T	LE	ØE	LT	T	LE	ØE	LT	T	LE	ØE
25001	-	-	-	-	-	-	-	-	-	-	-	-
25002	-	-	-	-	435.5	121.5	105	65 h6	467	153	105	65 h6
25003	466.5	93	82	42 h6	508.5	-	-	-	540	-	-	-
25004	514.5	-	-	-	-	-	-	-	-	-	-	-

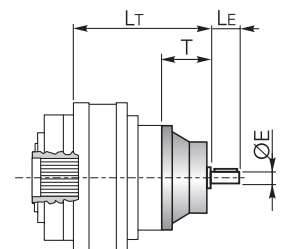



DIMENSIONI · DIMENSIONS

CHPL 25000 CF - Riduttore a vite senza fine CHM in entrata | *CHM input worm gearboxes*

CHPL	CHM 50					CHM 63					CHM 75				
	Lv	I	H	M	N	Lv	I	H	M	N	Lv	I	H	M	N
25001	-					-					-				
25002	-					-					-				
25003	499	50	110	60	80	508.5	63	135	72	95	487.5	75	161	86	112.5
25004	547					556.5					535.5				

CHPL	CHM 90					CHM 110					CHM 130					
	Lv	I	H	M	N	Lv	I	H	M	N	Lv	I	H	M	N	
25001	-					-					-					
25002	-					452	110	237.5	127.5	160	459	130	277.5	147.5	180	
25003	497.5	90	193	103	129.5	525				532						
25004	545.5															

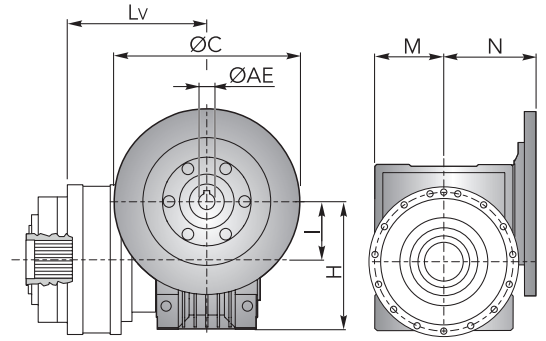

CHPL / CHPLB 25000 CF

CHPLB 25000 CF - Flange motori IEC | *IEC Motor flanges*

CHPLB	IEC 63				IEC 71				IEC 80				IEC 90				IEC 100			
	L	LP	P	ØD	L	LP	P	ØD	L	LP	P	ØD	L	LP	P	ØD	L	LP	P	ØD
25002	-				-				-				-				-			
25003	400	276	36	140	400	276	36	160	400	296	56	200	400	296	56	200	400	306	66	250
25004	473				473				473				473				473			

CHPLB	IEC 112				IEC 132				IEC 160				IEC 180				IEC 200			
	L	LP	P	ØD	L	LP	P	ØD	L	LP	P	ØD	L	LP	P	ØD	L	LP	P	ØD
25002	-				-				298	433	118	350	298	433	118	350	298	463	148	400
25003	400	306	66	250	400	340	100	300	400	379	139	350	400	379	139	350				
25004	473				473				473											

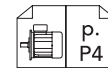
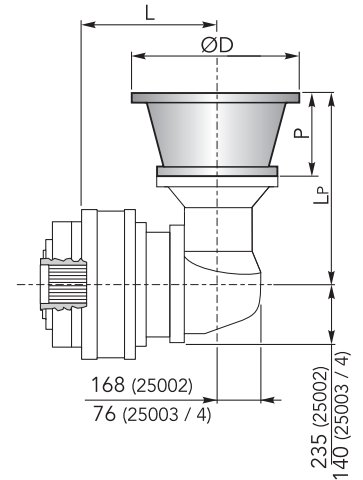

CHPLB 25000 CF - Alberi maschi entrata | *Male input shafts*

CHPLB	CM42					CM65					CP65					
	L	Lt	T	Le	ØE	L	Lt	T	Le	ØE	L	Lt	T	Le	ØE	
25002	-					298	436.5				298	468				
25003	400	333	93	82	42 h6	400	377.5	121.5	105	65 h6	400	409	153	105	65 h6	
25004	473					473					473					

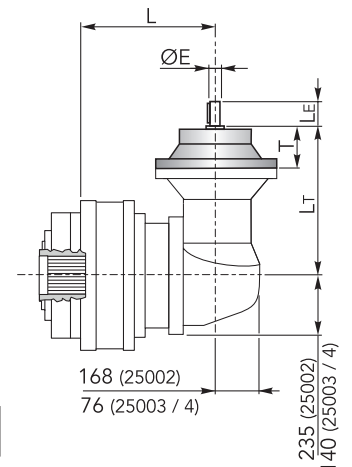

DIMENSIONI · DIMENSIONS

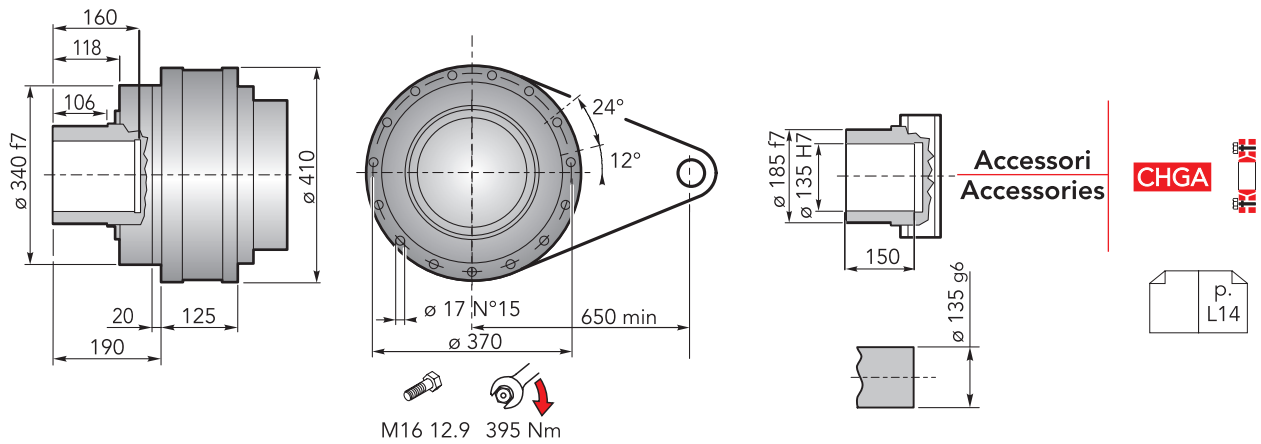

CHPL 25000 CFS - Flange motori IEC | IEC Motor flanges

CHPL	IEC 63			IEC 71			IEC 80			IEC 90			IEC 100			IEC 112		
	LP	P	ØD	LP	P	ØD	LP	P	ØD	LP	P	ØD	LP	P	ØD	LP	P	ØD
25001	-	-	-	-	-	-	-	-	-	-	-	-	-	-	-	-	-	-
25002	-	-	-	-	-	-	-	-	-	-	-	-	-	-	-	-	-	-
25003	409.5	36	140	409.5	36	160	429.5	56	200	429.5	56	200	439.5	66	250	439.5	66	250
25004	457.5	-	-	457.5	-	-	477.5	-	-	477.5	-	-	487.5	-	-	487.5	-	-

CHPL	IEC 132			IEC 160			IEC 180			IEC 200			IEC 225			IEC 250		
	LP	P	ØD	LP	P	ØD	LP	P	ØD	LP	P	ØD	LP	P	ØD	LP	P	ØD
25001	-	-	-	370	150	-	370	150	-	370	150	400	359	139	450	359	139	550
25002	-	-	-	432	118	-	432	118	350	462	148	-	-	-	-	-	-	-
25003	473.5	-	-	512.5	-	-	512.5	139	-	-	-	-	-	-	-	-	-	-
25004	521.5	100	300	560.5	139	-	-	-	-	-	-	-	-	-	-	-	-	-

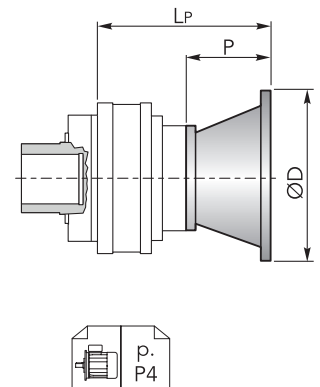

CHPL 25000 CFS - Alberi maschi entrata | Male input shafts

CHPL	CM42				CM65				CP65			
	LT	T	LE	ØE	LT	T	LE	ØE	LT	T	LE	ØE
25001	-	-	-	-	-	-	-	-	-	-	-	-
25002	-	-	-	-	435.5	121.5	105	65 h6	467	153	105	65 h6
25003	466.5	-	-	-	508.5	-	-	-	540	-	-	-
25004	514.5	93	82	42 h6	-	-	-	-	-	-	-	-

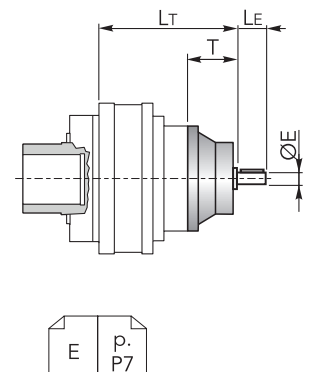



DIMENSIONI · DIMENSIONS

CHPL 25000 CFS - Riduttore a vite senza fine CHM in entrata | CHM input worm gearboxes

CHPL	CHM 50					CHM 63					CHM 75				
	Lv	I	H	M	N	Lv	I	H	M	N	Lv	I	H	M	N
25001	-					-					-				
25002	-					-					-				
25003	499	50	110	60	80	508.5	63	135	72	95	487.5	75	161	86	112.5
25004	547					556.5					535.5				

CHPL	CHM 90					CHM 110					CHM 130					
	Lv	I	H	M	N	Lv	I	H	M	N	Lv	I	H	M	N	
25001	-					-					-					
25002	-					452	110	237.5	127.5	160	459	130	277.5	147.5	180	
25003	497.5	90	193	103	129.5	525					532					
25004	545.5															

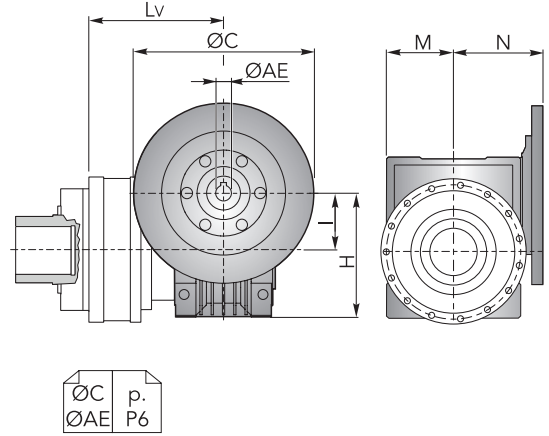

CHPLB 25000 CFS - Flange motori IEC | IEC Motor flanges

CHPLB	IEC 63				IEC 71				IEC 80				IEC 90				IEC 100			
	L	Lp	P	ØD	L	Lp	P	ØD	L	Lp	P	ØD	L	Lp	P	ØD	L	Lp	P	ØD
25002	-				-				-				-				-			
25003	400	276	36	140	400	276	36	160	400	296	56	200	400	296	56	200	400	306	66	250
25004	473				473				473				473				473			

CHPLB	IEC 112				IEC 132				IEC 160				IEC 180				IEC 200			
	L	Lp	P	ØD	L	Lp	P	ØD	L	Lp	P	ØD	L	Lp	P	ØD	L	Lp	P	ØD
25002	-				-				298	433	118		298	433	118		298	463	148	400
25003	400				400				400			350	400	379	139					
25004	473	306	66	250	473	340	100	300	473	379	139									

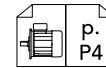
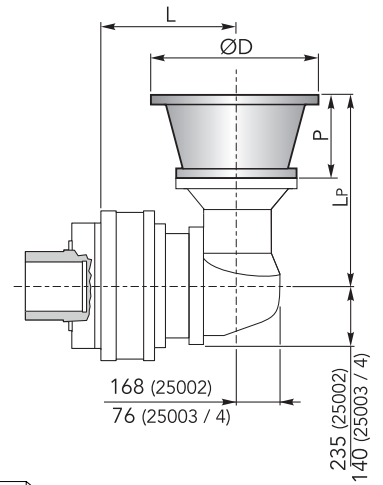

CHPLB 25000 CFS - Alberi maschi entrata | Male input shafts

CHPLB	CM42					CM65					CP65				
	L	Lt	T	Le	ØE	L	Lt	T	Le	ØE	L	Lt	T	Le	ØE
25002	-					298	436.5				298	468			
25003	400	333	93	82	42 h6	400	377.5	121.5	105	65 h6	400	409	153	105	65 h6
25004	473					473					473				

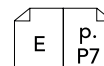
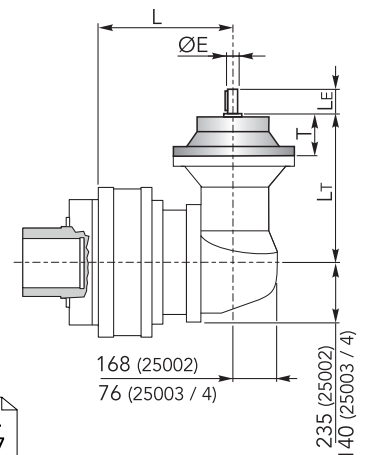

DIMENSIONI · DIMENSIONS

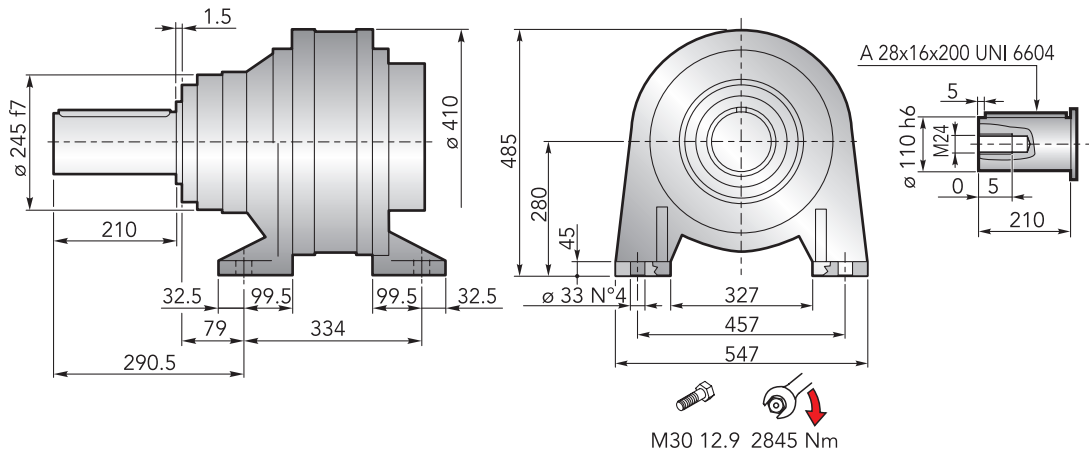

CHPL 25000 CCPC - Flange motori IEC | IEC Motor flanges

CHPL	IEC 63			IEC 71			IEC 80			IEC 90			IEC 100			IEC 112		
	LP	P	ØD	LP	P	ØD	LP	P	ØD	LP	P	ØD	LP	P	ØD	LP	P	ØD
25001	-	-	-	-	-	-	-	-	-	-	-	-	-	-	-	-	-	-
25002	-	-	-	-	-	-	-	-	-	-	-	-	-	-	-	-	-	-
25003	599.5	36	140	599.5	36	160	619.5	56	200	619.5	56	200	629.5	66	250	629.5	66	250
25004	647.5			647.5			667.5			667.5			667.5			677.5		

CHPL	IEC 132			IEC 160			IEC 180			IEC 200			IEC 225			IEC 250		
	LP	P	ØD	LP	P	ØD	LP	P	ØD	LP	P	ØD	LP	P	ØD	LP	P	ØD
25001	-	-	-	560	150	350	560	150	400	560	150	400	549	139	450	549	139	550
25002	-	-	-	622	118		622	118		622	148		-	-		-	-	
25003	663.5	100	300	702.5	139		702.5	139		-	-		-	-		-	-	
25004	711.5			750.5			-	-		-	-		-					

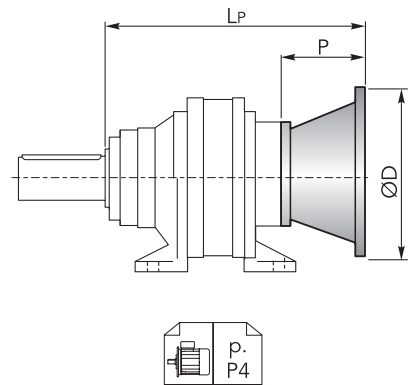

CHPL 25000 CCPC - Alberi maschi entrata | Male input shafts

CHPL	CM42				CM65				CP65			
	LT	T	LE	ØE	LT	T	LE	ØE	LT	T	LE	ØE
25001	-	-	-	-	-	-	-	-	-	-	-	-
25002	-	-	-	-	625.5	121.5	105	65 h6	657	153	105	65 h6
25003	656.5	93	82	42 h6	698.5	-	-	-	730	-	-	-
25004	704.5				-	-	-	-	-	-		

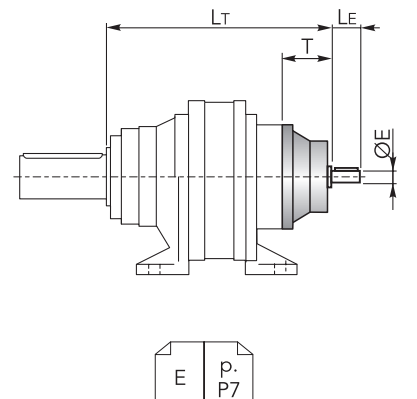



DIMENSIONI · DIMENSIONS

CHPL 25000 CCPC - Riduttore a vite senza fine CHM in entrata | *CHM input worm gearboxes*

CHPL	CHM 50					CHM 63					CHM 75				
	Lv	I	H	M	N	Lv	I	H	M	N	Lv	I	H	M	N
25001	-					-					-				
25002	-					-					-				
25003	689	50	110	60	80	698.5	63	135	72	95	677.5	75	161	86	112.5
25004	737					746.5					725.5				

CHPL	CHM 90					CHM 110					CHM 130					
	Lv	I	H	M	N	Lv	I	H	M	N	Lv	I	H	M	N	
25001	-					-					-					
25002	-					642	110	237.5	127.5	160	649	130	277.5	147.5	180	
25003	687.5	90	193	103	129.5	715				722						
25004	735.5															

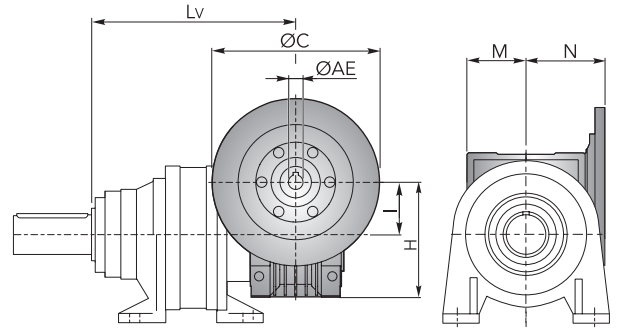

CHPL / CHPLB 25000 CCPC

CHPLB 25000 CCPC - Flange motori IEC | *IEC Motor flanges*

CHPLB	IEC 63				IEC 71				IEC 80				IEC 90				IEC 100			
	L	Lp	P	ØD	L	Lp	P	ØD	L	Lp	P	ØD	L	Lp	P	ØD	L	Lp	P	ØD
25002	-				-				-				-				-			
25003	590	276	36	140	590	276	36	160	590	296	56	200	590	296	56	200	590	306	66	250
25004	663				663				663				663				663			

CHPLB	IEC 112				IEC 132				IEC 160				IEC 180				IEC 200			
	L	Lp	P	ØD	L	Lp	P	ØD	L	Lp	P	ØD	L	Lp	P	ØD	L	Lp	P	ØD
25002	-				-				590	433	118		488	433	118		488	463	148	400
25003	590	306	66	250	590	340	100	300	663	379	139	350	590	379	139	350				
25004	663				663				663											

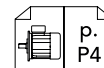
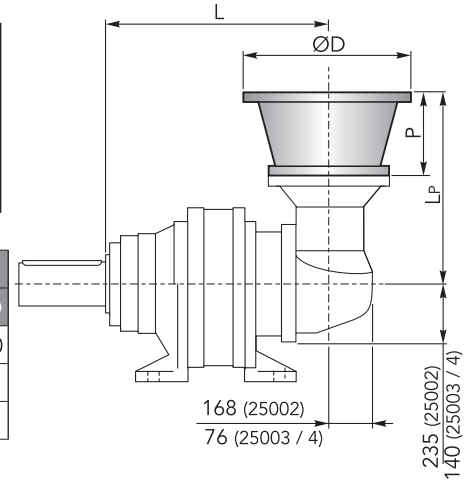

CHPLB 25000 CCPC - Alberi maschi entrata | *Male input shafts*

CHPLB	CM42					CM65					CP65					
	L	Lt	T	Le	ØE	L	Lt	T	Le	ØE	L	Lt	T	Le	ØE	
25002	-					590	436.5				590	468				
25003	590	333	93	82	42 h6	663	377.5	121.5	105	65 h6	663	409	153	105	65 h6	
25004	663					650					650					

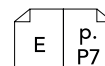
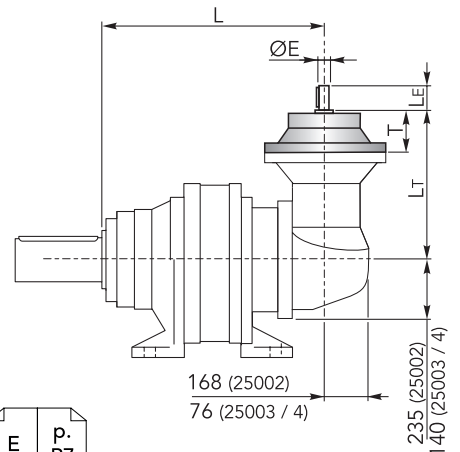

ACCESSORI · ACCESSORIES

CHFF

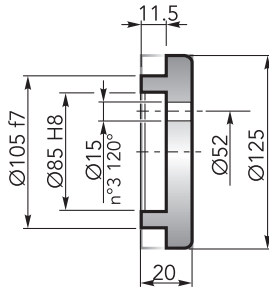
Fondello di arresto | *Stop bottom plate*Codice / Code:
1075.042.000

CHBS

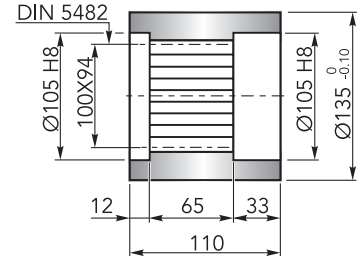
Boccola scanalata | *Splined bushing*Codice / Code:
8171.112.041

CHKB

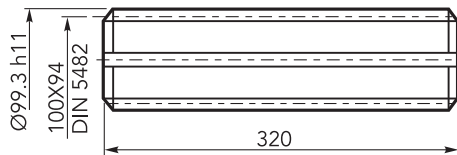
Barra scanalata | *Splined rod*Codice / Code:
3071.407.042

CHGA

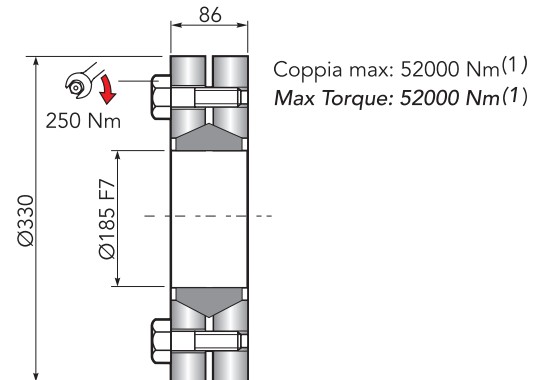
Giunto di attrito | *Shrink disc*Codice / Code:
5109.185.000

(1): Coppia max indicata è valida solo con calettatori forniti da Chiaravalli S.p.A.

(1): The maximum torque indicated is valid only with shrink discs supplied by Chiaravalli S.p.A.

CHFL

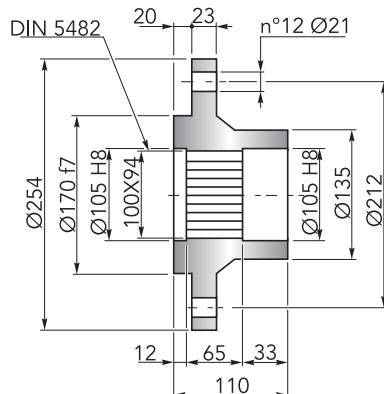
Flangia | *Flange*Codice / Code:
8171.104.098



CARICHI RADIALI (Fr) · RADIAL LOADS (Fr)

Nel diagramma seguente, sono indicati i carichi radiali F_r (N) applicabili sull'albero uscita in funzione della distanza di applicazione L rispetto alla battuta dell'albero.

The hereunder table shows the allowable radial loads F_r (N) on the output shaft with reference to the distance L .

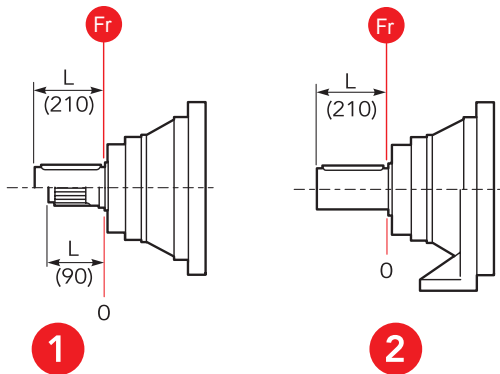
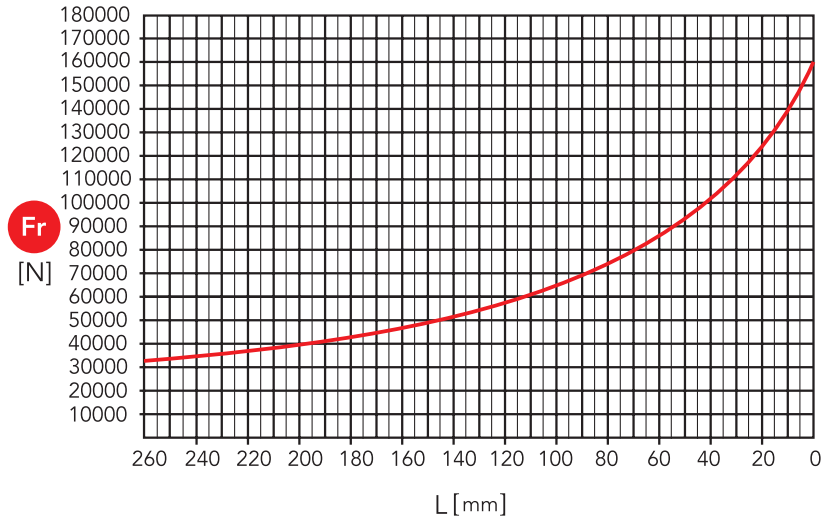

- 1 Uscita / Output: CMS, CMC
- 2 Uscita / Output: CCPC

CARICHI ASSIALI (Fa) · AXIAL LOADS (Fa)

Nella tabella seguente sono indicati i carichi assiali F_a (N) applicabili sull'albero di uscita in funzione della direzione di applicazione del carico e della versione.

The hereunder table shows the allowable axial loads F_a (N) on the output shaft with reference to the load direction and the output type.

	1	2	
F_a [N]	75000	75000	←
	95000	95000	→

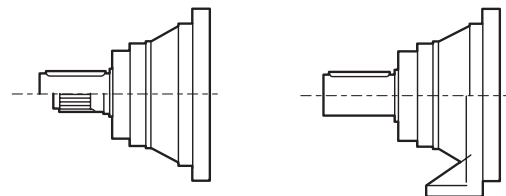

- 1 Uscita / Output: CMS, CMC
- 2 Uscita / Output: CCPC

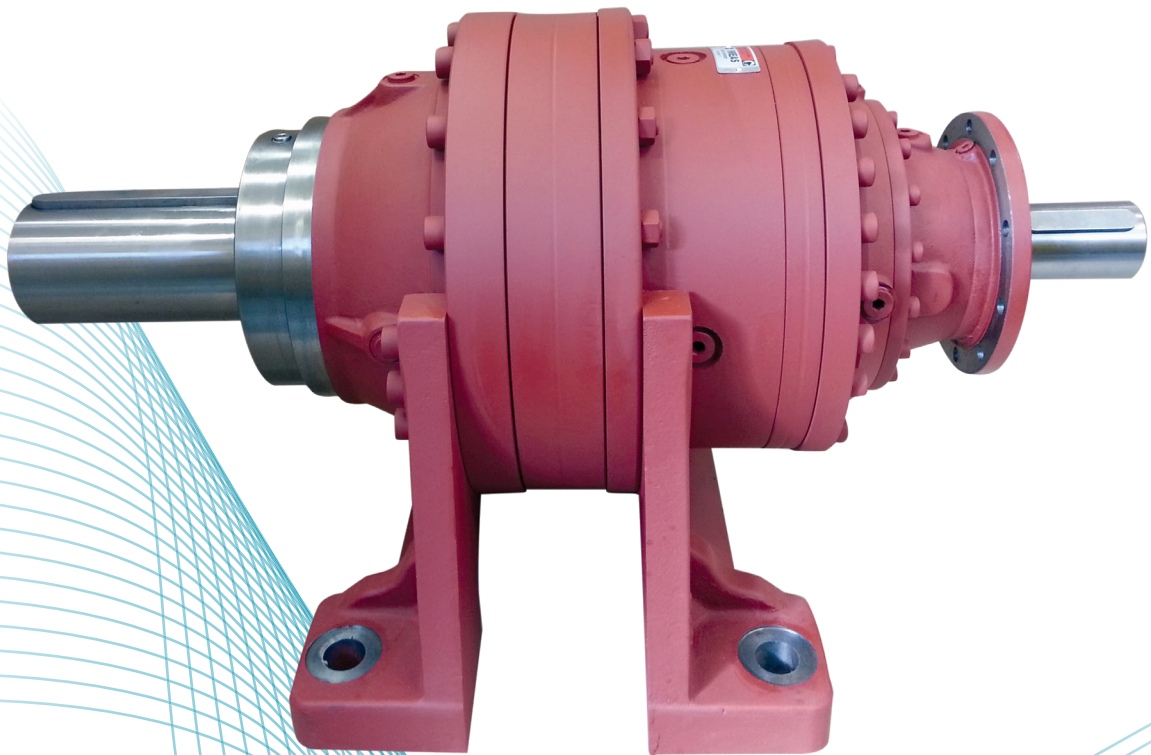



CHPL

30002	i 14.2 ÷ 35.1	2 reduction stages
30003	64.8 ÷ 134.4	3 reduction stages
30004	251.4 ÷ 1425.1	4 reduction stages

OUT

IN

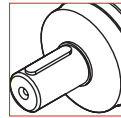

Ø110

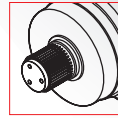

100x94
DIN 5482

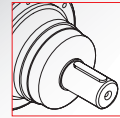

Ø42
Ø65

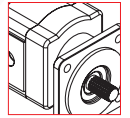

Hydraulic
Motor

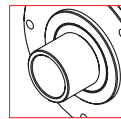

Ø135

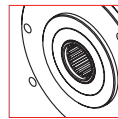

100x94
DIN 5482

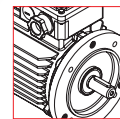

Electric
Motor

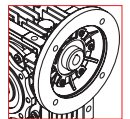

Worm
gearboxes

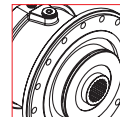

Brake

CHPLB

30003	i 52.7 ÷ 163.8	3 reduction stages
30004	306.0 ÷ 1385.5	4 reduction stages

OUT

IN

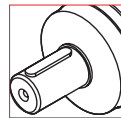

Ø110

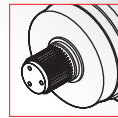

100x94
DIN 5482

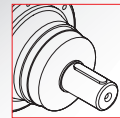

Ø42
Ø65

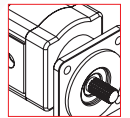

Hydraulic
Motor

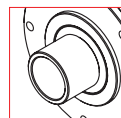

Ø135

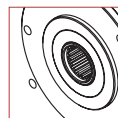

100x94
DIN 5482

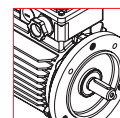

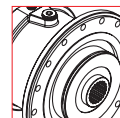

Electric
Motor

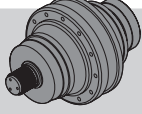
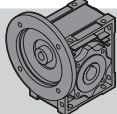

Brake

DATI TECNICI · TECHNICAL DATA

 CHPL	i	T _{2n} (n ₁ = 1400 rpm) 10.000h FS=1 [Nm]	P _{1n} (n ₁ = 1400 rpm) 10.000h FS=1 [kW]	T ₂ Max [Nm]	P _t 1400 rpm [kW]	IEC (B5)	 CHM	 CM/CP
30002	14.2	16236	180	62760	34	160 180 200	CHM 110 CHM 130 CHM 150	CM65 CP65
	17.1	17109	157.5	62760				
	22.4	18143	127.5	62760				
	29.1	13864	75	48520				
	35.1	15050	67.5	48520				
30003	64.8	20974	52.8	62760	23	63 71 80 90 100 112 132 160 180	CHM 50 CHM 63 CHM 75 CHM 90 CHM 110 CHM 130 CHM 150	CM42 CM65 CP65
	73.5	21807	48.4	62760				
	88.6	22704	41.8	62760				
	102.9	23591	37.4	62760				
	124.3	23469	30.8	62760				
	134.4	23563	28.6	62760				
30004	251.4	26769	18	62760	17	63 71 80 90 100 112 132 160	CHM 50 CHM 63 CHM 75 CHM 90	CM42
	300.9	26699	15	62760				
	314.9	27941	15	62760				
	328.5	29148	15	62760				
	362.7	28965	13.5	62760				
	379.6	26946	12	62760				
	396	28115	12	62760				
	427.1	29308	11.6	62760				
	477.3	30494	10.8	62760				
	517.4	30608	10	62760				
	576	31347	9.2	62760				
	623.7	30992	8.4	62760				
	694.3	31214	7.6	62760				
	752.6	32055	7.2	62760				
	838.9	33745	6.8	62760				
	1015.5	26431	4.4	48520				
1425.1	26976	3.2	48520					

n_{1max} = 2800 rpm



per ulteriori rapporti consultare l'ufficio tecnico

for information consult the technical office

Solo per / only for CHPL 30002 n_{1max} = 2000 rpm

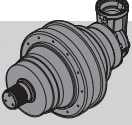

DATI TECNICI · TECHNICAL DATA

 CHPLB	i	T _{2n} (n ₁ = 1400 rpm) 10.000h FS=1 [Nm]	P _{1n} (n ₁ = 1400 rpm) 10.000h FS=1 [kW]	T ₂ Max [Nm]	P _t 1400 rpm [kW]	IEC (B5)	 CM/CP
30003	52.7	20611	63.8	62760	23	160 180	CM65 CP65
	66.4	21492	52.8	62760			
	80	22657	46.2	62760			
	104.5	22549	35.2	62760			
	135.9	18327	22	48520			
	163.8	19881	19.8	48520			
30004	306	28242	15	62760	17	63 71 80 90 100 112 132 160	CM42 CM65 CP65
	352.6	28242	13	62760			
	385	28242	12	62760			
	460.7	29433	10.8	62760			
	519.8	23369	7.6	48520			
	598.9	24091	6.8	48520			
	676.7	32024	8	62760			
	729.3	24159	5.6	48520			
	819.1	25196	5.2	48520			
	951.2	25320	4.5	48520			
	1385.5	27045	3.3	48520			

CHPLB 30000

n_{1max} = 2800 rpm

per ulteriori rapporti consultare l'ufficio tecnico

for information consult the technical office

DIMENSIONI · DIMENSIONS

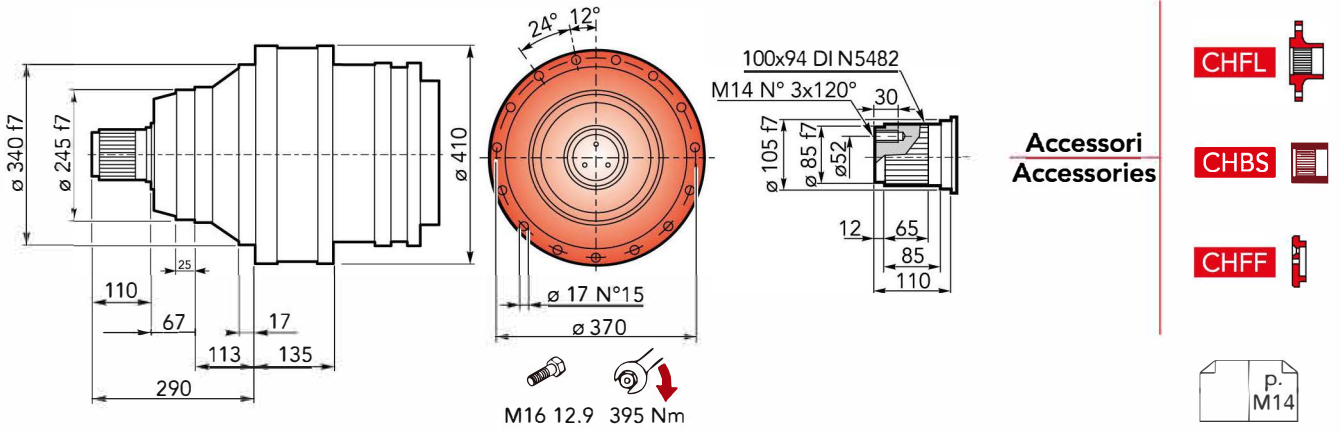

CHPL 30000 CMS - Flange motori IEC | IEC Motor flanges

CHPL	IEC 63			IEC 71			IEC 80			IEC 90			IEC 100		
	LP	P	ØD	LP	P	ØD	LP	P	ØD	LP	P	ØD	LP	P	ØD
30002	-			-			-			-			-		
30003	424.5	36	140	424.5	36	160	444.5	56	200	444.5	56	200	454.5	66	250
30004	485.5			485.5			505.5			505.5			515.5		

CHPL	IEC 112			IEC 132			IEC 160			IEC 180			IEC 200		
	LP	P	ØD	LP	P	ØD	LP	P	ØD	LP	P	ØD	LP	P	ØD
30002	-			-			435	118		435	118	350	465	148	400
30003	454.5			488.5			527.5			527.5	139		-		
30004	515.5	66	250	549.5	100	300	588.5	139		-			-		

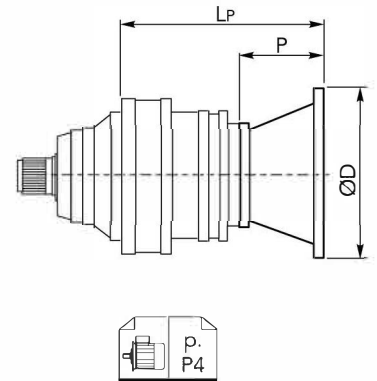

CHPL 30000 CMS - Alberi maschi entrata | Male input shafts

CHPL	CM42				CM65				CP65			
	LT	T	LE	ØE	LT	T	LE	ØE	LT	T	LE	ØE
30002	-				438.5				470			
30003	481.5				523.5	121.5	105	65 h6	555	153	105	65 h6
30004	542.5	93	82	42 h6	-				-			

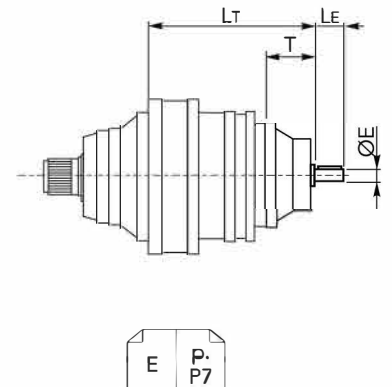



DIMENSIONI · DIMENSIONS

CHPL 30000 CMS - Riduttore a vite senza fine CHM in entrata | *CHM input worm gearboxes*

CHPL	CHM 50					CHM 63					CHM 75				
	Lv	I	H	M	N	Lv	I	H	M	N	Lv	I	H	M	N
30002	-					-					-				
30003	514	50	110	60	80	523.5	63	135	72	95	502.5	75	161	86	112.5
30004	575					584.5					563.5				

CHPL	CHM 90					CHM 110					CHM 130					
	Lv	I	H	M	N	Lv	I	H	M	N	Lv	I	H	M	N	
30002	-					455	110	237.5	127.5	160	462	130	277.5	147.5	180	
30003	512.5	90	193	103	129.5	540					547					
30004	573.5					-					-					

CHPL	CHM 150				
	Lv	I	H	M	N
30002	477	150	320	170	210
30003	562				
30004	-				

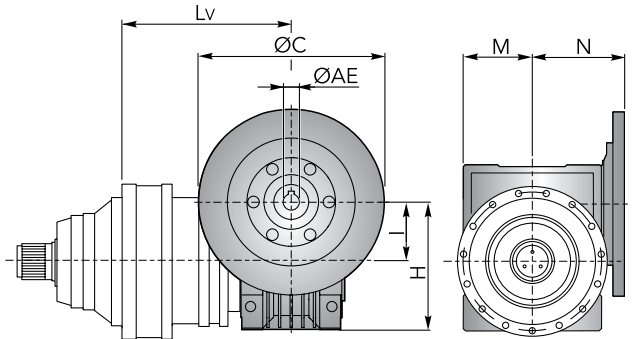

$\begin{matrix} \text{ØC} & \text{p.} \\ \text{ØAE} & \text{P6} \end{matrix}$

CHPLB 30000 CMS - Flange motori IEC | *IEC Motor flanges*

CHPLB	IEC 63				IEC 71				IEC 80				IEC 90			
	L	LP	P	ØD	L	LP	P	ØD	L	LP	P	ØD	L	LP	P	ØD
30003	-				-				-				-			
30004	490	276	36	140	490	276	36	160	490	296	56	200	490	296	56	200

CHPLB	IEC 100				IEC 112				IEC 132				IEC 160				IEC 180							
	L	LP	P	ØD	L	LP	P	ØD	L	LP	P	ØD	L	LP	P	ØD	L	LP	P	ØD				
30003	-				-				-				452	433	118	350	452	433	118	350	-			
30004	490	306	66	250	490	306	66	250	490	340	100	300	490	379	139	350	-				-			

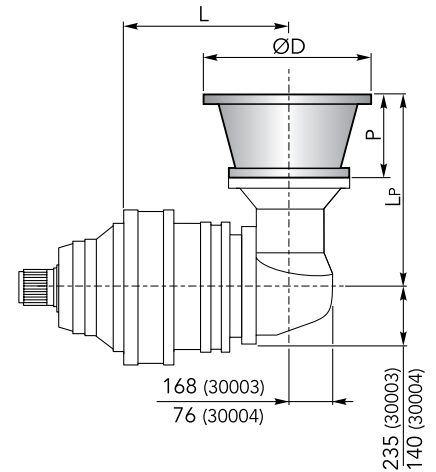

$\begin{matrix} \text{p.} \\ \text{P4} \end{matrix}$

CHPLB 30000 CMS - Alberi maschi entrata | *Male input shafts*

CHPLB	CM42					CM65					CP65				
	L	L _T	T	L _E	ØE	L	L _T	T	L _E	ØE	L	L _T	T	L _E	ØE
30003	-					452	436.5	121.5	105	65 h6	452	468	153	105	65 h6
30004	490	333	93	82	42 h6	490	377.5	121.5	105	65 h6	490	409	153	105	65 h6

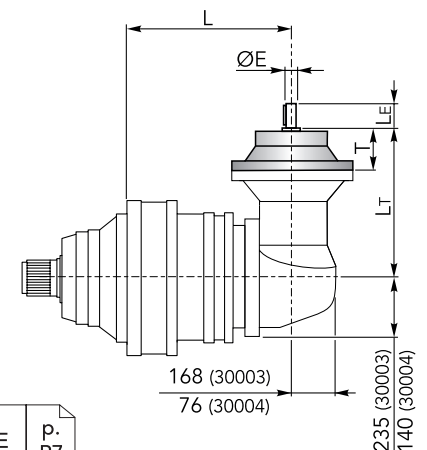

$\begin{matrix} \text{E} & \text{p.} \\ \text{P7} \end{matrix}$

DIMENSIONI · DIMENSIONS

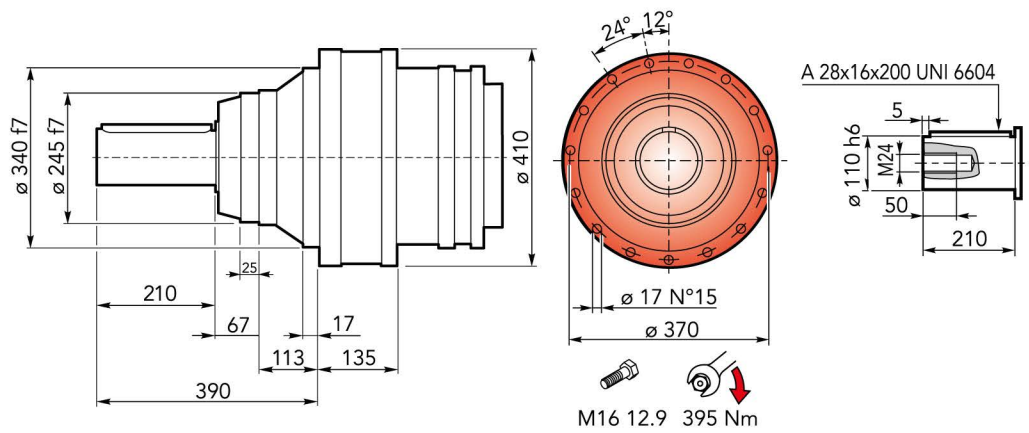

CHPL 30000 CMC - Flange motori IEC | IEC Motor flanges

CHPL	IEC 63			IEC 71			IEC 80			IEC 90			IEC 100		
	LP	P	ØD	LP	P	ØD	LP	P	ØD	LP	P	ØD	LP	P	ØD
30002	-	-	-	-	-	-	-	-	-	-	-	-	-	-	-
30003	424.5	36	140	424.5	36	160	444.5	56	200	444.5	56	200	454.5	66	250
30004	485.5	-	-	485.5	-	-	505.5	-	-	505.5	-	-	515.5	-	-

CHPL	IEC 112			IEC 132			IEC 160			IEC 180			IEC 200		
	LP	P	ØD	LP	P	ØD	LP	P	ØD	LP	P	ØD	LP	P	ØD
30002	-	-	-	-	-	-	435	118	350	435	118	350	465	148	400
30003	454.5	66	250	488.5	100	300	527.5	139	-	527.5	139	-	-	-	-
30004	515.5	-	-	549.5	-	-	588.5	-	-	-	-	-	-	-	-

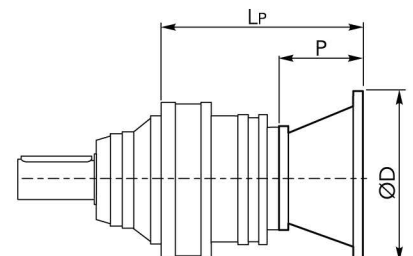

CHPL 30000 CMC - Alberi maschi entrata | Male input shafts

CHPL	CM42				CM65				CP65			
	LT	T	LE	ØE	LT	T	LE	ØE	LT	T	LE	ØE
30002	-	-	-	-	438.5	121.5	105	65 h6	470	153	105	65 h6
30003	481.5	93	82	42 h6	523.5	-	-	-	555	-	-	-
30004	542.5	-	-	-	-	-	-	-	-	-	-	-

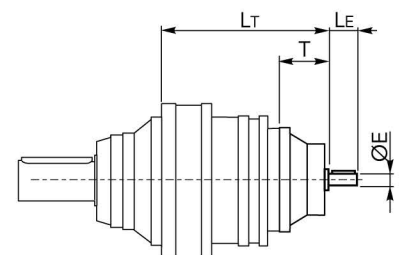



DIMENSIONI · DIMENSIONS

CHPL 30000 CMC - Riduttore a vite senza fine CHM in entrata | *CHM input worm gearboxes*

CHPL	CHM 50					CHM 63					CHM 75				
	Lv	I	H	M	N	Lv	I	H	M	N	Lv	I	H	M	N
30002	-					-					-				
30003	514	50	110	60	80	523.5	63	135	72	95	502.5	75	161	86	112.5
30004	575					584.5					563.5				

CHPL	CHM 90					CHM 110					CHM 130					
	Lv	I	H	M	N	Lv	I	H	M	N	Lv	I	H	M	N	
30002	-					455	110	237.5	127.5	160	462	130	277.5	147.5	180	
30003	512.5	90	193	103	129.5	540					547					
30004	573.5					-					-					

CHPL	CHM 150				
	Lv	I	H	M	N
30002	477				
30003	562	150	320	170	210
30004	-				

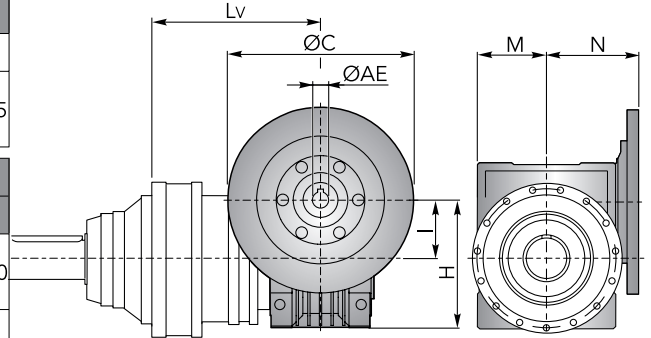

CHPLB 30000 CMC - Flange motori IEC | *IEC Motor flanges*

CHPLB	IEC 63				IEC 71				IEC 80				IEC 90			
	L	Lp	P	ØD	L	Lp	P	ØD	L	Lp	P	ØD	L	Lp	P	ØD
30003	-				-				-				-			
30004	490	276	36	140	490	276	36	160	490	296	56	200	490	296	56	200

CHPLB	IEC 100				IEC 112				IEC 132				IEC 160				IEC 180							
	L	Lp	P	ØD	L	Lp	P	ØD	L	Lp	P	ØD	L	Lp	P	ØD	L	Lp	P	ØD				
30003	-				-				-				452	433	118	350	452	433	118	350	-			
30004	490	306	66	250	490	306	66	250	490	340	100	300	490	379	139		-				-			

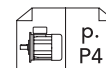
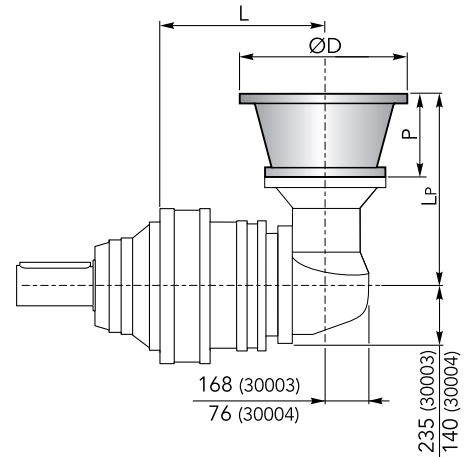

CHPLB 30000 CMC - Alberi maschi entrata | *Male input shafts*

CHPLB	CM42					CM65					CP65					
	L	Lt	T	Le	ØE	L	Lt	T	Le	ØE	L	Lt	T	Le	ØE	
30003	-					452	436.5	121.5	105	65 h6	452	468	153	105	65 h6	
30004	490	333	93	82	42 h6	490	377.5				490	409				

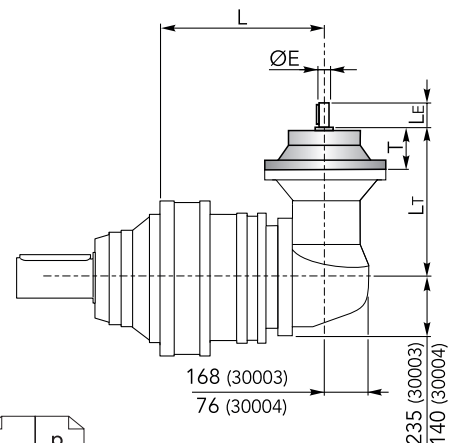

DIMENSIONI · DIMENSIONS

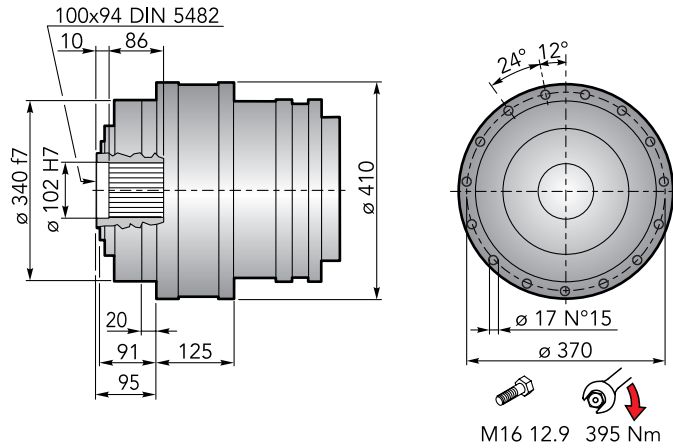

Accessori
Accessories

CHKB

p.
M14

CHPL 30000 CF - Flange motori IEC | IEC Motor flanges

CHPL	IEC 63			IEC 71			IEC 80			IEC 90			IEC 100		
	LP	P	ØD	LP	P	ØD	LP	P	ØD	LP	P	ØD	LP	P	ØD
30002	-			-			-			-			-		
30003	414.5	36	140	414.5	36	160	434.5	56	200	434.5	56	200	444.5	66	250
30004	475.5			475.5			495.5			495.5			505.5		

CHPL	IEC 112			IEC 132			IEC 160			IEC 180			IEC 200		
	LP	P	ØD	LP	P	ØD	LP			LP	P	ØD	LP	P	ØD
30002	-			-			425	118		425	118	350	455	148	400
30003	444.5			478.5			517.5		350	517.5	139		-		
30004	505.5	66	250	539.5	100	300	578.5	139		-			-		

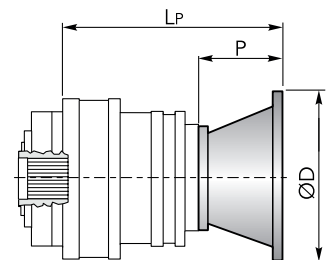

p.
P4

CHPL 30000 CF - Alberi maschi entrata | Male input shafts

CHPL	CM42				CM65				CP65			
	LT	T	LE	ØE	LT	T	LE	ØE	LT	T	LE	ØE
30002	-				428.5	121.5	105	65 h6	460	153	105	65 h6
30003	471.5				513.5				545			
30004	532.5	93	82	42 h6	-				-			

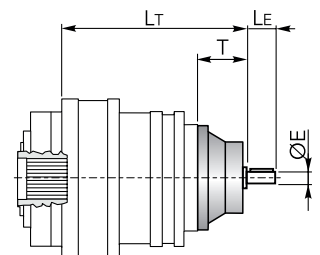

E
p.
P7



DIMENSIONI · DIMENSIONS

CHPL 30000 CF - Riduttore a vite senza fine CHM in entrata | CHM input worm gearboxes

CHPL	CHM 50					CHM 63					CHM 75				
	Lv	I	H	M	N	Lv	I	H	M	N	Lv	I	H	M	N
30002	-					-					-				
30003	504	50	110	60	80	513.5	63	135	72	95	492.5	75	161	86	112.5
30004	565					574.5					553.5				

CHPL	CHM 90					CHM 110					CHM 130				
	Lv	I	H	M	N	Lv	I	H	M	N	Lv	I	H	M	N
30002	-					-					-				
30003	502.5	90	193	103	129.5	530	110	237.5	127.5	160	452	130	277.5	147.5	180
30004	563.5														

CHPL	CHM 150				
	Lv	I	H	M	N
30002	467				
30003	552	150	320	170	210
30004	-				

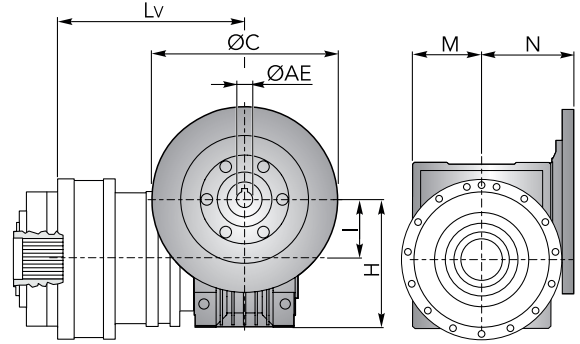

CHPL / CHPLB 30000 CF

CHPLB 30000 CF - Flange motori IEC | IEC Motor flanges

CHPLB	IEC 63				IEC 71				IEC 80				IEC 90			
	L	LP	P	ØD	L	LP	P	ØD	L	LP	P	ØD	L	LP	P	ØD
30003	-				-				-				-			
30004	480	276	36	140	480	276	36	160	480	296	56	200	480	296	56	200

CHPLB	IEC 100				IEC 112				IEC 132				IEC 160				IEC 180							
	L	LP	P	ØD	L	LP	P	ØD	L	LP	P	ØD	L	LP	P	ØD	L	LP	P	ØD				
30003	-				-				-				442	433	118	350	442	433	118	350	-			
30004	480	306	66	250	480	306	66	250	480	340	100	300	480	379	139		-				-			

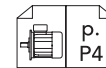
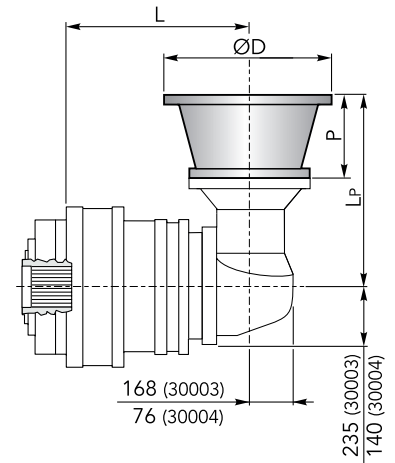

CHPLB 30000 CF - Alberi maschi entrata | Male input shafts

CHPLB	CM42					CM65					CP65				
	L	Lt	T	Le	ØE	L	Lt	T	Le	ØE	L	Lt	T	Le	ØE
30003	-					442	436.5	121.5	105	65 h6	442	468	153	105	65 h6
30004	480	333	93	82	42 h6	480	377.5				480	409			

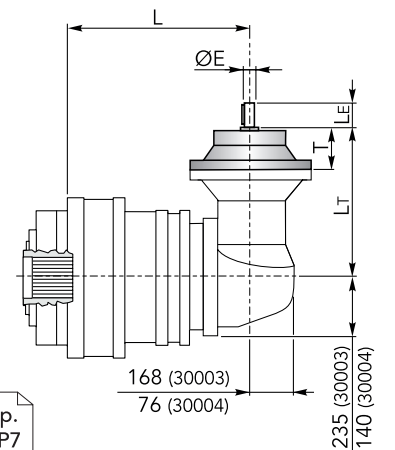

DIMENSIONI · DIMENSIONS

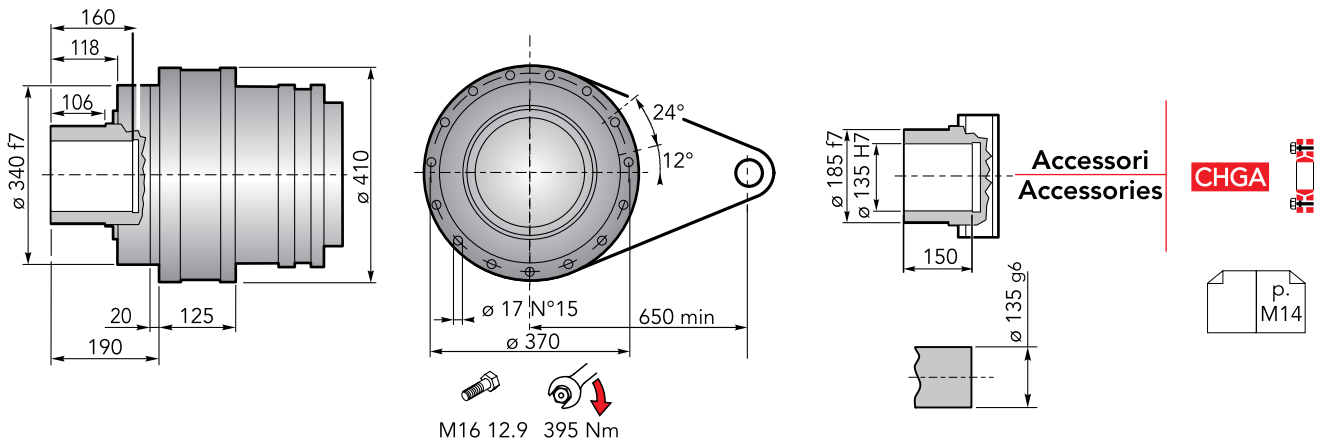

CHPL 30000 CFS - Flange motori IEC | IEC Motor flanges

CHPL	IEC 63			IEC 71			IEC 80			IEC 90			IEC 100		
	LP	P	ØD	LP	P	ØD	LP	P	ØD	LP	P	ØD	LP	P	ØD
30002	-			-			-			-			-		
30003	414.5	36	140	414.5	36	160	434.5	56	200	434.5	56	200	444.5	66	250
30004	475.5			475.5			495.5			495.5			505.5		

CHPL	IEC 112			IEC 132			IEC 160			IEC 180			IEC 200		
	LP	P	ØD	LP	P	ØD	LP	P	ØD	LP	P	ØD	LP	P	ØD
30002	-			-			425	118		425	118	350	455	148	400
30003	444.5			478.5			517.5			517.5	139		-		
30004	505.5	66	250	539.5	100	300	578.5	139		-			-		

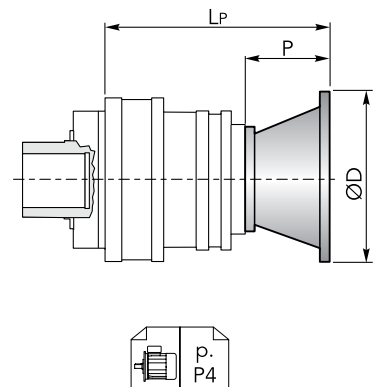

CHPL 30000 CFS - Alberi maschi entrata | Male input shafts

CHPL	CM42				CM65				CP65				
	LT	T	LE	ØE	LT	T	LE	ØE	LT	T	LE	ØE	
30002	-				428.5				460				
30003	471.5				513.5	121.5	105	65 h6	545	153	105	65 h6	
30004	532.5	93	82	42 h6	-				-				

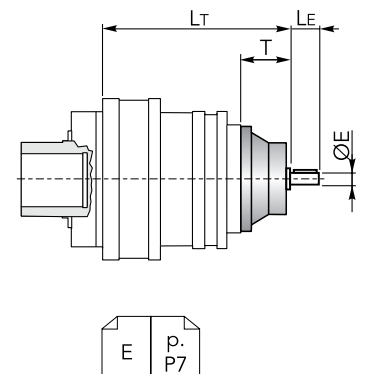



DIMENSIONI · DIMENSIONS

CHPL 30000 CFS - Riduttore a vite senza fine CHM in entrata | CHM input worm gearboxes

CHPL	CHM 50					CHM 63					CHM 75				
	Lv	I	H	M	N	Lv	I	H	M	N	Lv	I	H	M	N
30002	-					-					-				
30003	504					513.5					492.5				
30004	565	50	110	60	80	574.5	63	135	72	95	553.5	75	161	86	112.5

CHPL	CHM 90					CHM 110					CHM 130				
	Lv	I	H	M	N	Lv	I	H	M	N	Lv	I	H	M	N
30002	-					-					-				
30003	502.5					445					452				
30004	563.5	90	193	103	129.5	530	110	237.5	127.5	160	537	130	277.5	147.5	180

CHPL	CHM 150				
	Lv	I	H	M	N
30002	467				
30003	552	150	320	170	210
30004	-				

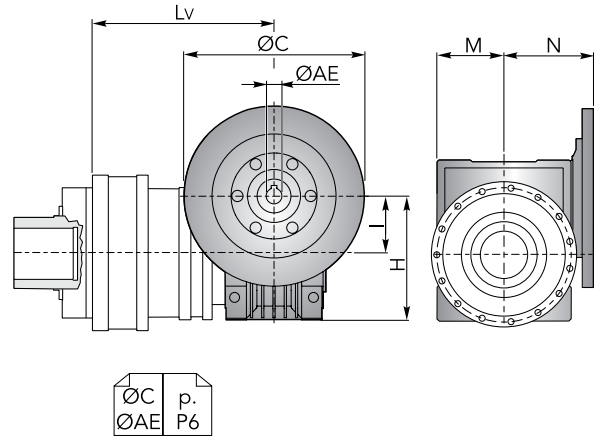

CHPL / CHPLB 30000 CFS

CHPLB 30000 CFS - Flange motori IEC | IEC Motor flanges

CHPLB	IEC 63				IEC 71				IEC 80				IEC 90			
	L	LP	P	ØD	L	LP	P	ØD	L	LP	P	ØD	L	LP	P	ØD
30003	-				-				-				-			
30004	480	276	36	140	480	276	36	160	480	296	56	200	480	296	56	200

CHPLB	IEC 100				IEC 112				IEC 132				IEC 160				IEC 180							
	L	LP	P	ØD	L	LP	P	ØD	L	LP	P	ØD	L	LP	P	ØD	L	LP	P	ØD				
30003	-				-				-				442	433	118	350	442	433	118	350	-			
30004	480	306	66	250	480	306	66	250	480	340	100	300	480	379	139	350	-				-			

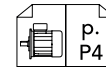
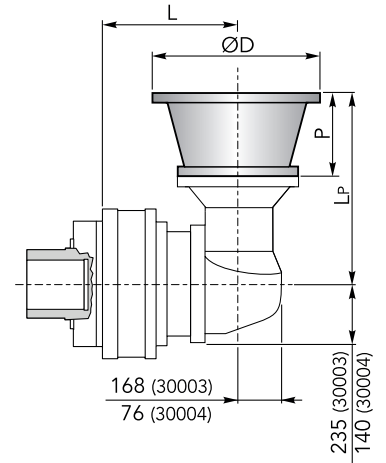

CHPLB 30000 CFS - Alberi maschi entrata | Male input shafts

CHPLB	CM42					CM65					CP65					
	L	Lt	T	Le	ØE	L	Lt	T	Le	ØE	L	Lt	T	Le	ØE	
30003	-					442	436.5				442	468				
30004	480	333	93	82	42 h6	480	377.5	121.5	105	65 h6	480	409	153	105	65 h6	

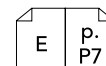
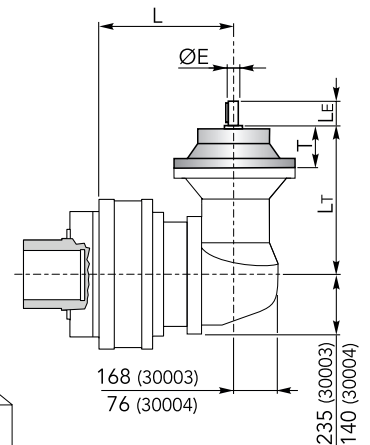

DIMENSIONI · DIMENSIONS

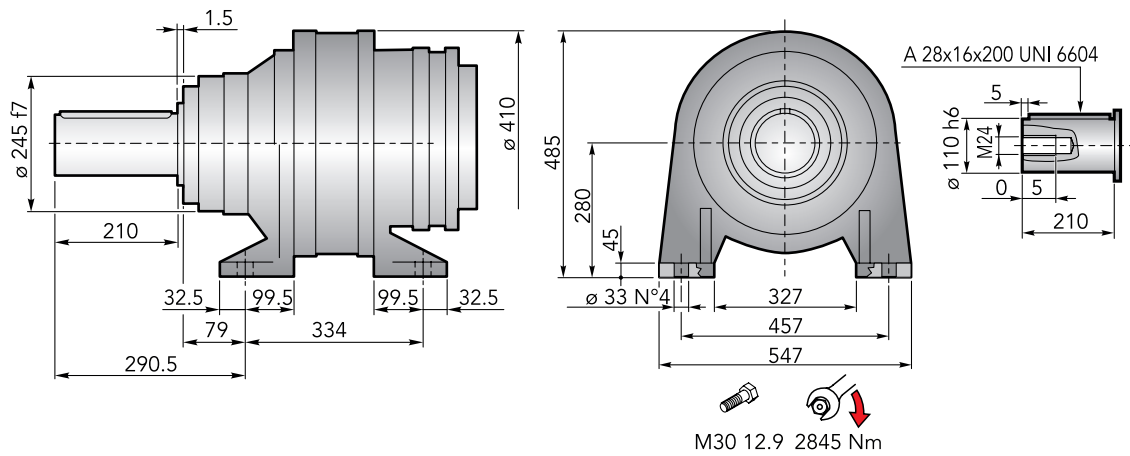

CHPL 30000 CCPC - Flange motori IEC | IEC Motor flanges

CHPL	IEC 63			IEC 71			IEC 80			IEC 90			IEC 100		
	LP	P	ØD	LP	P	ØD	LP	P	ØD	LP	P	ØD	LP	P	ØD
30002	-	-	-	-	-	-	-	-	-	-	-	-	-	-	-
30003	604.5	36	140	604.5	36	160	624.5	56	200	624.5	56	200	634.5	66	250
30004	665.5	-	-	665.5	-	-	685.5	-	-	685.5	-	-	695.5	-	-

CHPL	IEC 112			IEC 132			IEC 160			IEC 180			IEC 200		
	LP	P	ØD	LP	P	ØD	LP	P	ØD	LP	P	ØD	LP	P	ØD
30002	-	-	-	-	-	-	615	118	350	615	118	350	645	148	400
30003	634.5	66	250	668.5	100	300	707.5	139	-	707.5	139	-	-	-	-
30004	695.5	-	-	729.5	-	-	768.5	-	-	-	-	-	-	-	-

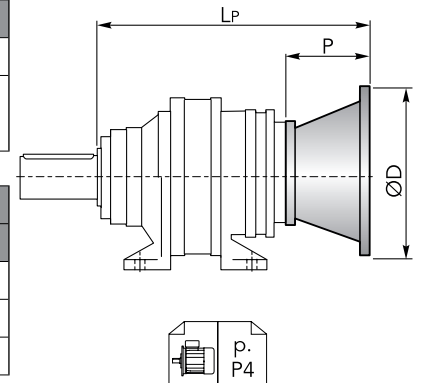

CHPL 30000 CCPC - Alberi maschi entrata | Male input shafts

CHPL	CM42				CM65				CP65			
	LT	T	LE	ØE	LT	T	LE	ØE	LT	T	LE	ØE
30002	-	-	-	-	618.5	121.5	105	65 h6	650	153	105	65 h6
30003	661.5	93	82	42 h6	703.5	-	-	-	735	-	-	-
30004	722.5	-	-	-	-	-	-	-	-	-	-	-

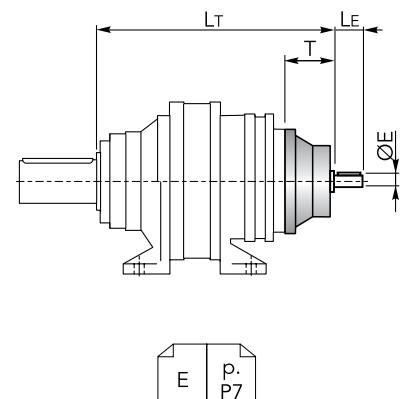



DIMENSIONI · DIMENSIONS

CHPL 30000 CCPC - Riduttore a vite senza fine CHM in entrata | CHM input worm gearboxes

CHPL	CHM 50					CHM 63					CHM 75				
	Lv	I	H	M	N	Lv	I	H	M	N	Lv	I	H	M	N
30002	-					-					-				
30003	694	50	110	60	80	703.5	63	135	72	95	682.5	75	161	86	112.5
30004	755					764.5					743.5				

CHPL	CHM 90					CHM 110					CHM 130				
	Lv	I	H	M	N	Lv	I	H	M	N	Lv	I	H	M	N
30002	-					-					-				
30003	692.5	90	193	103	129.5	635	110	237.5	127.5	160	642	130	277.5	147.5	180
30004	753.5														

CHPL	CHM 150				
	Lv	I	H	M	N
30002	657				
30003	742	150	320	170	210
30004	-				

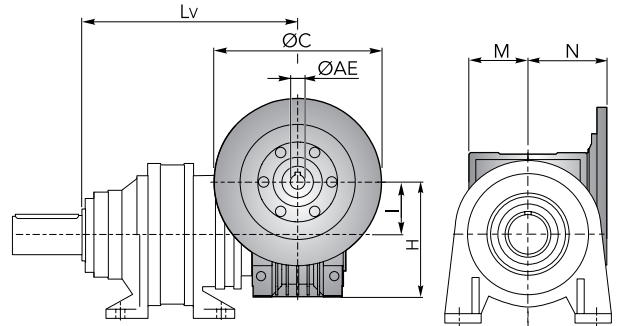

CHPL / CHPLB 30000 CCPC

CHPLB 30000 CCPC - Flange motori IEC | IEC Motor flanges

CHPLB	IEC 63				IEC 71				IEC 80				IEC 90			
	L	LP	P	ØD	L	LP	P	ØD	L	LP	P	ØD	L	LP	P	ØD
30003	-				-				-				-			
30004	670	276	36	140	670	276	36	160	670	296	56	200	670	296	56	200

CHPLB	IEC 100				IEC 112				IEC 132				IEC 160				IEC 180							
	L	LP	P	ØD	L	LP	P	ØD	L	LP	P	ØD	L	LP	P	ØD	L	LP	P	ØD				
30003	-				-				-				632	433	118	350	632	433	118	350	-			
30004	670	306	66	250	670	306	66	250	670	340	100	300	670	379	139		-				-			

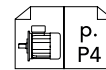
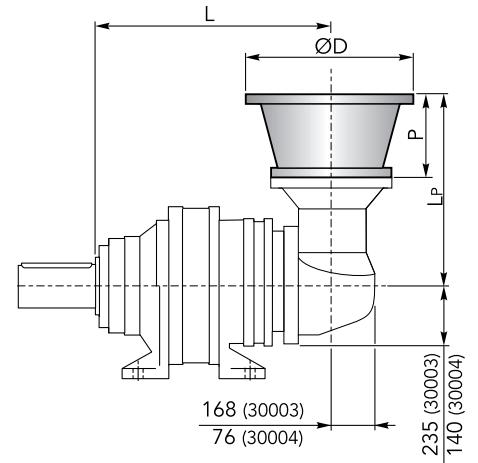

CHPLB 30000 CCPC - Alberi maschi entrata | Male input shafts

CHPLB	CM42					CM65					CP65				
	L	L _T	T	L _E	ØE	L	L _T	T	L _E	ØE	L	L _T	T	L _E	ØE
30003	-					632	436.5	121.5	105	65 h6	632	468	153	105	65 h6
30004	670	333	93	82	42 h6	670	377.5				670	409			

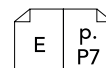
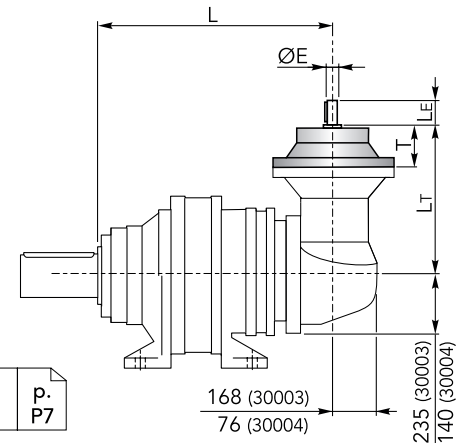

ACCESSORI · ACCESSORIES

CHFF

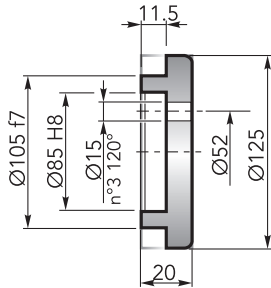
Fondello di arresto | *Stop bottom plate*Codice / Code:
1075.042.000

CHBS

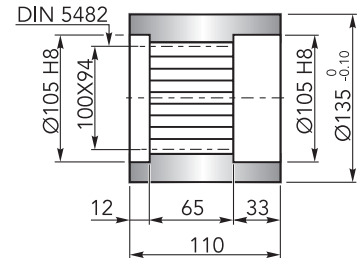
Boccola scanalata | *Splined bushing*Codice / Code:
8171.112.041

CHKB

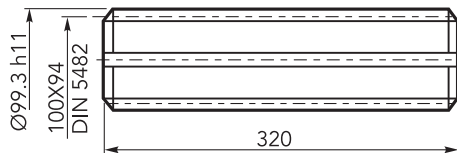
Barra scanalata | *Splined rod*Codice / Code:
3071.407.042

CHGA

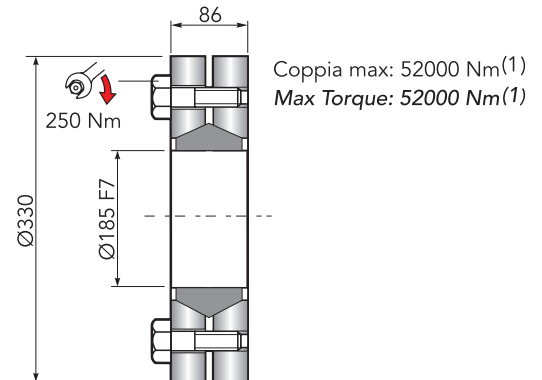
Giunto di attrito | *Shrink disc*Codice / Code:
5109.185.000

(1): Coppia max indicata è valida solo con calettatori forniti da Chiaravalli S.p.A.

(1): The maximum torque indicated is valid only with shrink discs supplied by Chiaravalli S.p.A.

CHFL

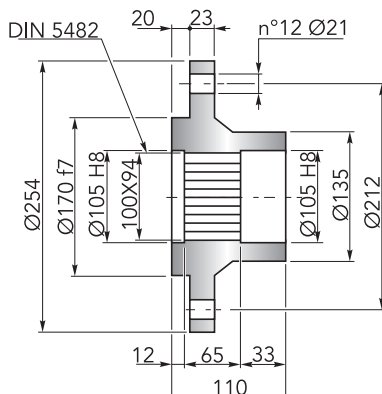
Flangia | *Flange*Codice / Code:
8171.104.098



CARICHI RADIALI (Fr) · RADIAL LOADS (Fr)

Nel diagramma seguente, sono indicati i carichi radiali Fr (N) applicabili sull'albero uscita in funzione della distanza di applicazione L rispetto alla battuta dell'albero.

The hereunder table shows the allowable radial loads Fr (N) on the output shaft with reference to the distance L .

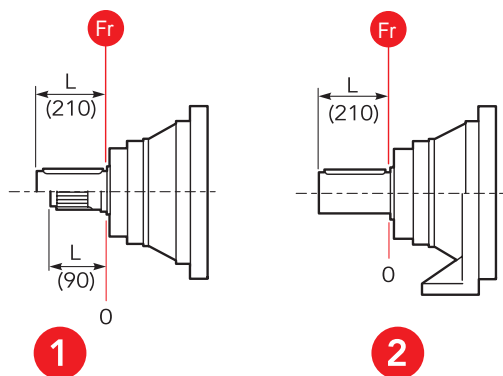
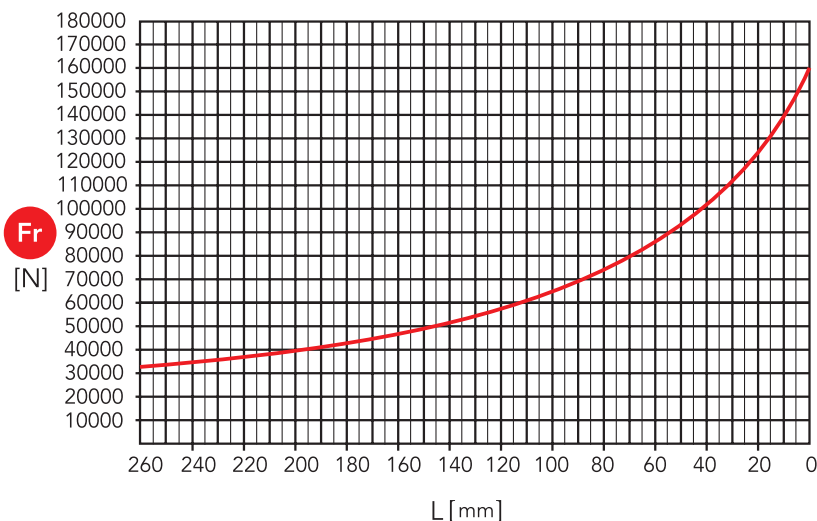

- 1 Uscita / Output: CMS, CMC
- 2 Uscita / Output: CCPC

CARICHI ASSIALI (Fa) · AXIAL LOADS (Fa)

Nella tabella seguente sono indicati i carichi assiali Fa (N) applicabili sull'albero di uscita in funzione della direzione di applicazione del carico e della versione.

The hereunder table shows the allowable axial loads Fa (N) on the output shaft with reference to the load direction and the output type.

	1	2	
Fa [N]	75000	75000	←
	95000	95000	→

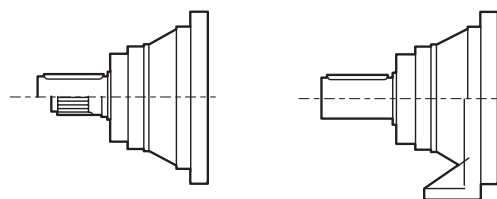

- 1 Uscita / Output: CMS, CMC
- 2 Uscita / Output: CCPC

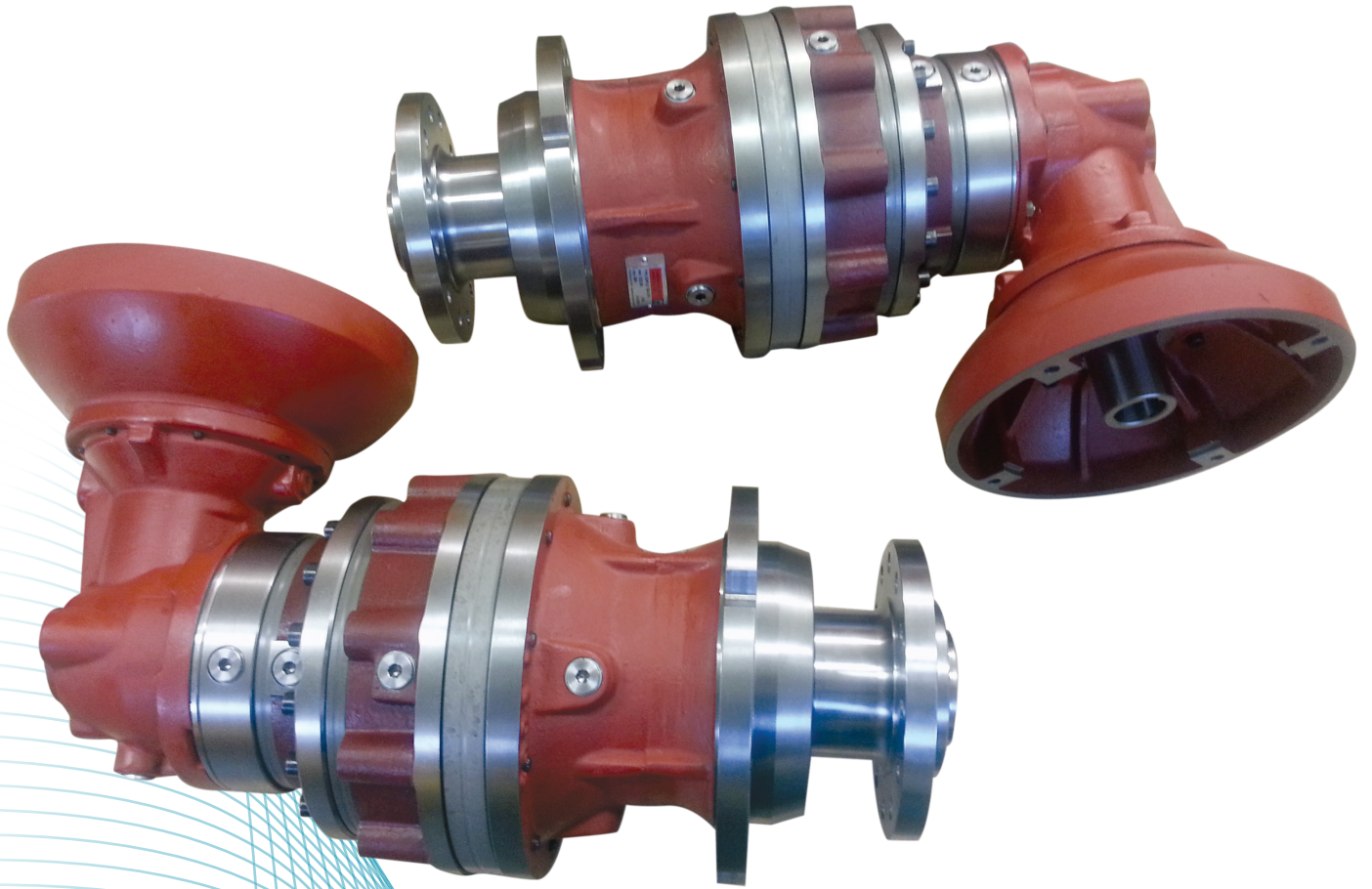

www.chiaravalli.com





— ITALY —

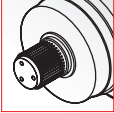
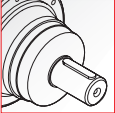
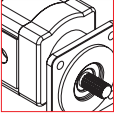
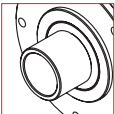
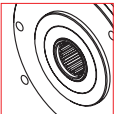
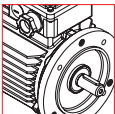
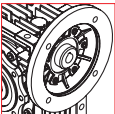
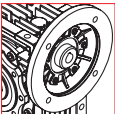
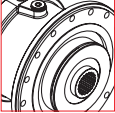

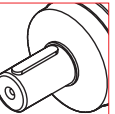

CHPL

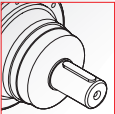
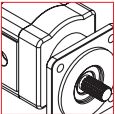
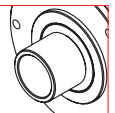
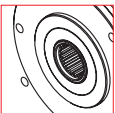
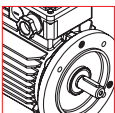
	<i>i</i>		OUT		IN	
35001	4.00 ÷ 4.71	1 reduction stage		 Ø120 W120x3x38x8f DIN 5480		 Ø42 Ø65 Hydraulic Motor
35002	14.2 ÷ 27.0	2 reduction stages		 Ø135 N120x5x22x9H DIN 5480		 Electric Motor
35003	53.7 ÷ 230.3	3 reduction stages				 Worm gearboxes
35004	191.0 ÷ 1289.7	4 reduction stages				Brake

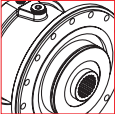
CHPLB

	<i>i</i>		OUT		IN	
35002	12.3 ÷ 22.0	2 reduction stages		 Ø120 W120x3x38x8f DIN 5480		 Ø42 Ø65 Hydraulic Motor
35003	43.7 ÷ 123.0	3 reduction stages		 Ø135 N120x5x22x9H DIN 5480		 Electric Motor
35004	185.6 ÷ 1253.8	4 reduction stages				Brake

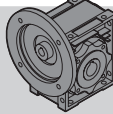
DATI TECNICI · TECHNICAL DATA

CHPL	i	T _{2n} (n ₁ = 1400 rpm) 10.000h FS=1 [Nm]	P _{1n} (n ₁ = 1400 rpm) 10.000h FS=1 [kW]	T ₂ Max [Nm]	P _t 1400 rpm [kW]	IEC			
						(B5)			
35001	4	16065	607	63112	54	160	180	-	-
	4.71	13692	440	53790		200	225		
35002	14.2	20295	225	63112	34	160 200	180	CHM 110 CHM 130 CHM 150	CM65 CP65
	17.1	20530	189	63112					
	20.2	18477	144	53790					
	22.4	21771	153	63112					
	27	18524	108	53790					
35003	53.7	23701	72	63112	23	63 80 100 132 180	71 90 112 160	CHM 50 CHM 63 CHM 75 CHM 90 CHM 110 CHM 130 CHM 150	CM42 CM65 CP65
	58.7	25908	72	63112					
	64.8	25343	63.8	63112					
	70.7	25745	59.4	63112					
	83.2	22440	44	53790					
	88.6	27483	50.6	63112					
	99.6	24178	39.6	53790					
	108.7	23455	35.2	53790					
	121	24496	35.2	53790					
	136.2	25716	30.8	53790					
	158.1	25586	26.4	53790					
	164.1	26556	26.4	53790					
	191.1	25772	22	53790					
	230.3	27953	19.8	53790					
35004	191	30507	27	63112	17	63 80 100 132	71 90 112 160	CHM 50 CHM 63 CHM 75 CHM 90	CM42
	208.6	31466	25.5	63112					
	230.3	32696	24	63112					
	251.4	35692	22.5	63112					
	277.5	32010	19.5	63112					
	303.1	34963	19.5	63112					
	328.5	34978	18	63112					
	362.7	35402	16.5	63112					
	379.6	33682	15	63112					
	437.1	34906	13.5	63112					
	496	35209	12	63112					
	583.5	31757	9.2	53790					
	677.7	32070	8	53790					
	703.4	33288	8	53790					
	762.5	34280	7.6	53790					
	816.8	34789	7.2	53790					
	987	35031	6	53790					
1067.3	35356	5.6	53790						
1289.7	36619	4.8	53790						

n_{1max} = 2800 rpm



per ulteriori rapporti consultare l'ufficio tecnico

for information consult the technical office

Solo per / only for CHPL 35001 n_{1max} = 1500 rpmSolo per / only for CHPL 35002 n_{1max} = 2000 rpm



DATI TECNICI · TECHNICAL DATA

 CHPLB	i	T _{2n} (n ₁ = 1400 rpm) 10.000h FS=1 [Nm]	P _{1n} (n ₁ = 1400 rpm) 10.000h FS=1 [kW]	T ₂ Max [Nm]	P _t 1400 rpm [kW]	IEC (B5)	 CM
35002	12.3	18987	243	63112	34	160 180 200	CM65 CP65
	14.5	17409	189	53790			
	18.7	20313	171	63112			
	22	18867	135	53790			
35003	43.7	24109	90	63112	23	160 180	CM65 CP65
	52.7	26167	81	63112			
	66.4	25602	62.9	63112			
	80	27218	55.5	63112			
	94.1	23478	40.7	53790			
	123	25108	33.3	53790			
35004	185.6	31401	28.6	63112	17	63 71 80 90 100 112 132 160	CM42 CM65 CP65
	202.7	31655	26.4	63112			
	223.7	32024	24.2	63112			
	244.3	31793	22	63112			
	292.5	34260	19.8	63112			
	319.4	33253	17.6	63112			
	352.6	36710	17.6	63112			
	385	35619	15.7	63112			
	414.8	29347	12	53790			
	452.9	29578	11.1	53790			
	542	32447	10.2	53790			
	591.8	32207	9.2	53790			
	658.8	32268	8.3	53790			
	741.3	32275	7.4	53790			
	860.9	33611	6.6	53790			
	1037.7	37138	6.1	53790			
1253.8	36713	5	53790				

n_{1max} = 2800 rpm

per ulteriori rapporti consultare l'ufficio tecnico

for information consult the technical office

Solo per / only for CHPLB 35002 n_{1max} = 2000 rpm

CHPLB 35000

DIMENSIONI · DIMENSIONS

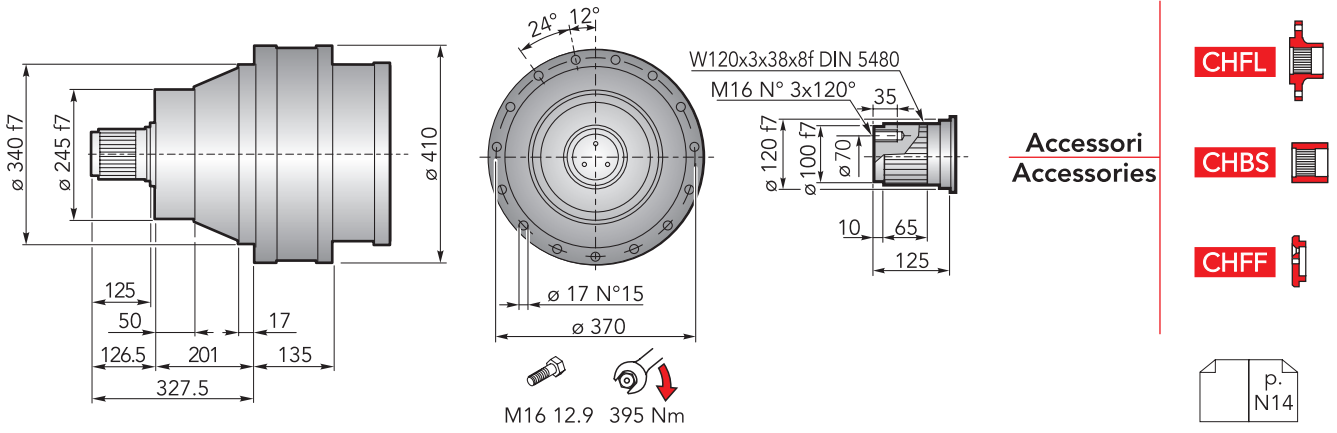

CHPL 35000 CMS - Flange motori IEC | IEC Motor flanges

CHPL	IEC 63			IEC 71			IEC 80			IEC 90			IEC 100			IEC 112		
	LP	P	ØD	LP	P	ØD	LP	P	ØD	LP	P	ØD	LP	P	ØD	LP	P	ØD
35001	-	-	-	-	-	-	-	-	-	-	-	-	-	-	-	-	-	-
35002	-	-	-	-	-	-	-	-	-	-	-	-	-	-	-	-	-	-
35003	424.5	36	140	424.5	36	160	444.5	56	200	444.5	56	200	454.5	66	250	454.5	66	250
35004	485.5			485.5			505.5			505.5			505.5			515.5		
CHPL	IEC 132			IEC 160			IEC 180			IEC 200			IEC 225			IEC 250		
	LP	P	ØD	LP	P	ØD	LP	P	ØD	LP	P	ØD	LP	P	ØD	LP	P	ØD
35001	-	-	-	380	150	350	380	150	350	380	150	400	369	139	450	369	139	550
35002	-	-	-	435	118		435	118		465	148		-	-	-	-		
35003	488.5	100	300	527.5	139	350	527.5	139	-	-	-	-	-	-	-	-	-	
35004	549.5			588.5			-	-	-	-								

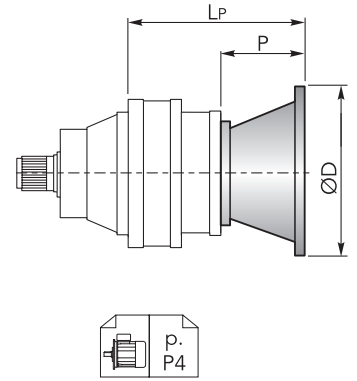

CHPL 35000 CMS - Alberi maschi entrata | Male input shafts

CHPL	CM42				CM65				CP65			
	LT	T	LE	ØE	LT	T	LE	ØE	LT	T	LE	ØE
35001	-	-	-	-	-	-	-	-	-	-	-	-
35002	-	-	-	-	438.5	121.5	105	65 h6	470	153	105	65 h6
35003	481.5	93	82	42 h6	523.5	-	-	-	555	-	-	-
35004	542.5				-	-	-	-	-			

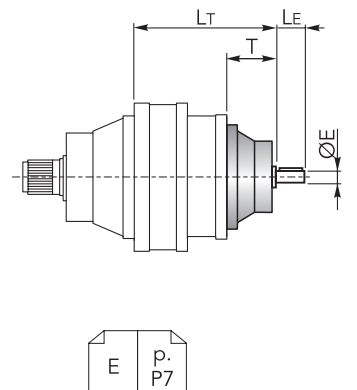



DIMENSIONI · DIMENSIONS

CHPL 35000 CMS - Riduttore a vite senza fine CHM in entrata | *CHM input worm gearboxes*

CHPL	CHM 50					CHM 63					CHM 75				
	Lv	I	H	M	N	Lv	I	H	M	N	Lv	I	H	M	N
35001	-					-					-				
35002	-					-					-				
35003	514	50	110	60	80	523.5	63	135	72	95	502.5	75	161	86	112.5
35004	575					584.5					563.5				

CHPL	CHM 90					CHM 110					CHM 130					
	Lv	I	H	M	N	Lv	I	H	M	N	Lv	I	H	M	N	
35001	-					-					-					
35002	-					455	110	237.5	127.5	160	462	130	277.5	147.5	180	
35003	512.5	90	193	103	129.5	540					547					
35004	573.5															

CHPL	CHM 150				
	Lv	I	H	M	N
35001	-				
35002	477	150	320	170	210
35003	562				
35004	-				

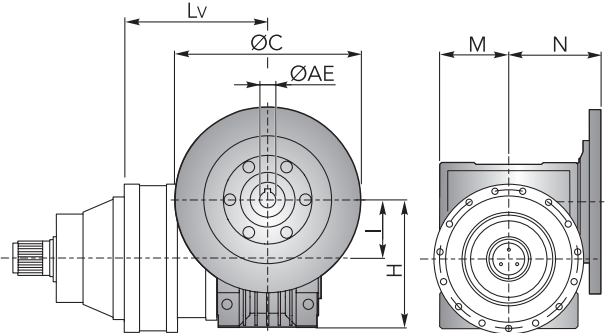

CHPLB 35000 CMS - Flange motori IEC | *IEC Motor flanges*

CHPLB	IEC 63				IEC 71				IEC 80				IEC 90				IEC 100			
	L	Lp	P	ØD	L	Lp	P	ØD	L	Lp	P	ØD	L	Lp	P	ØD	L	Lp	P	ØD
35002	-				-				-				-				-			
35003	-				-				-				-				-			
35004	490	276	36	140	490	276	36	160	490	296	56	200	490	296	56	200	490	306	66	250

CHPLB	IEC 112				IEC 132				IEC 160				IEC 180				IEC 200				
	L	Lp	P	ØD	L	Lp	P	ØD	L	Lp	P	ØD	L	Lp	P	ØD	L	Lp	P	ØD	
35002	-				-				295	433	118	350	295	433	118	350	295	463	148	400	
35003	-				-				452				452								
35004	490	306	66	250	490	340	66	300	490	379	139										

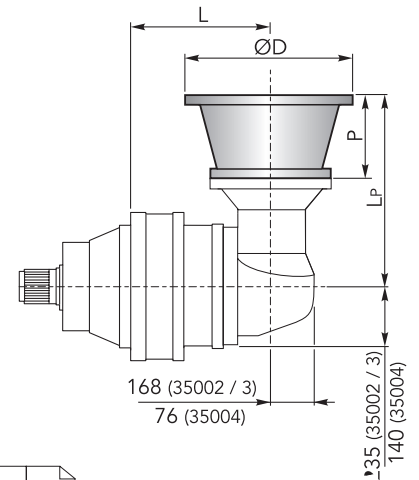

CHPLB 35000 CMS - Alberi maschi entrata | *Male input shafts*

CHPLB	CM42					CM65					CP65					
	L	Lt	T	Le	ØE	L	Lt	T	Le	ØE	L	Lt	T	Le	ØE	
35002	-					295	436.5				295	468				
35003	-					452		121.5	105	65 h6	452		153	105	65 h6	
35004	490	333	93	82	42 h6	490	377.5				490	409				

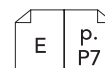
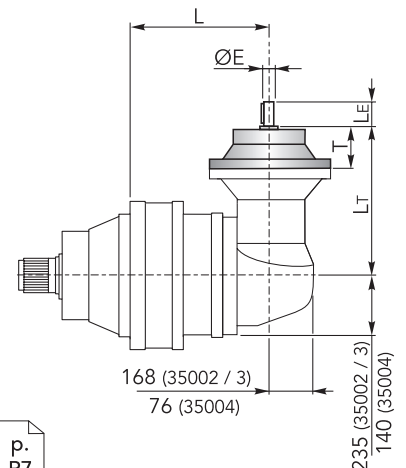

DIMENSIONI · DIMENSIONS

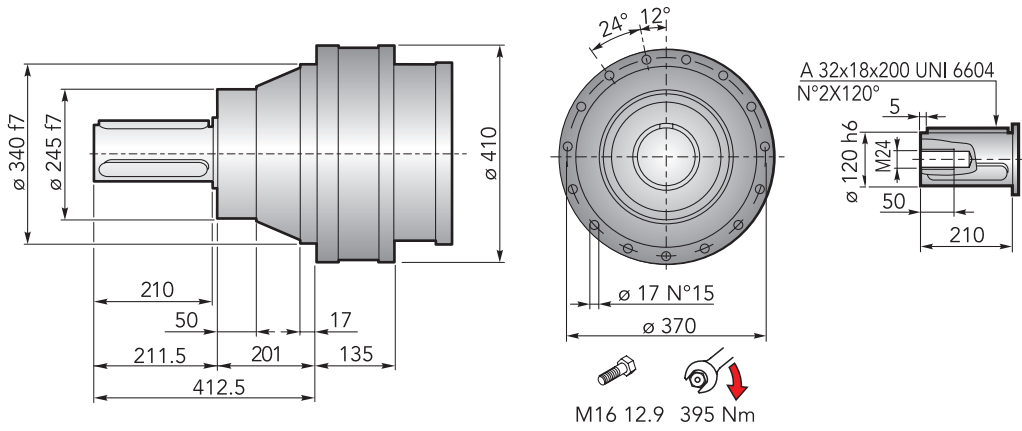

CHPL 35000 CMC - Flange motori IEC | IEC Motor flanges

CHPL	IEC 63			IEC 71			IEC 80			IEC 90			IEC 100			IEC 112		
	LP	P	ØD	LP	P	ØD	LP	P	ØD	LP	P	ØD	LP	P	ØD	LP	P	ØD
35001	-	-	-	-	-	-	-	-	-	-	-	-	-	-	-	-	-	-
35002	-	-	-	-	-	-	-	-	-	-	-	-	-	-	-	-	-	-
35003	424.5	36	140	424.5	36	160	444.5	56	200	444.5	56	200	454.5	66	250	454.5	66	250
35004	485.5			485.5			505.5			505.5			515.5			515.5		
CHPL	IEC 132			IEC 160			IEC 180			IEC 200			IEC 225			IEC 250		
	LP	P	ØD	LP	P	ØD	LP	P	ØD	LP	P	ØD	LP	P	ØD	LP	P	ØD
35001	-	-	-	380	150	350	380	150	350	380	150	400	369	139	450	369	139	550
35002	-	-	-	435	118		435	118		465	148		-	-	-	-		
35003	488.5	100	300	527.5	139	527.5	139	-	-	-	-	-	-					
35004	549.5			588.5		-	-	-	-									

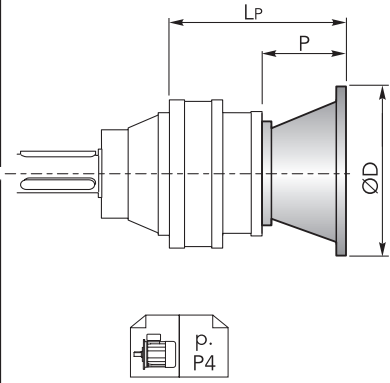

CHPL 35000 CMC - Alberi maschi entrata | Male input shafts

CHPL	CM42				CM65				CP65			
	LT	T	LE	ØE	LT	T	LE	ØE	LT	T	LE	ØE
35001	-	-	-	-	-	-	-	-	-	-	-	-
35002	-	-	-	-	438.5	121.5	105	65 h6	470	153	105	65 h6
35003	481.5	93	82	42 h6	523.5	-	-	-	555	-	-	-
35004	542.5			-	-	-	-	-				

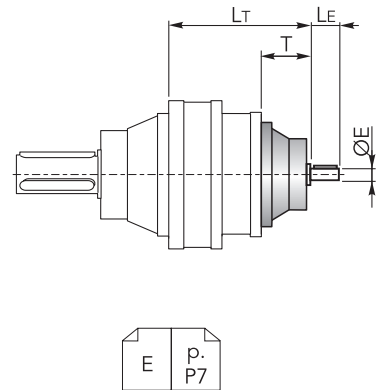



DIMENSIONI · DIMENSIONS

CHPL 35000 CMC - Riduttore a vite senza fine CHM in entrata | *CHM input worm gearboxes*

CHPL	CHM 50					CHM 63					CHM 75				
	Lv	I	H	M	N	Lv	I	H	M	N	Lv	I	H	M	N
35001	-					-					-				
35002	-					-					-				
35003	514	50	110	60	80	523.5	63	135	72	95	502.5	75	161	86	112.5
35004	575					584.5					563.5				

CHPL	CHM 90					CHM 110					CHM 130					
	Lv	I	H	M	N	Lv	I	H	M	N	Lv	I	H	M	N	
35001	-					-					-					
35002	-					455	110	237.5	127.5	160	462	130	277.5	147.5	180	
35003	512.5	90	193	103	129.5	540					547					
35004	573.5															

CHPL	CHM 150				
	Lv	I	H	M	N
35001	-				
35002	477	150	320	170	210
35003	562				
35004	-				

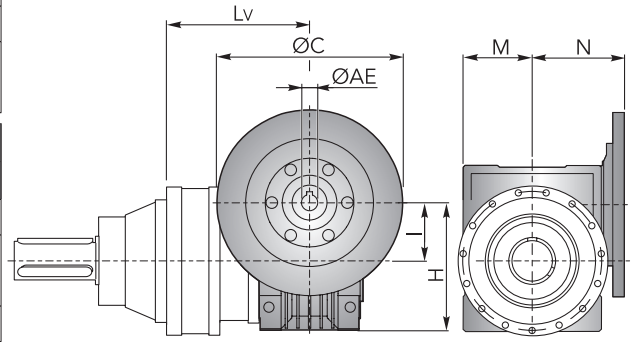

CHPLB 35000 CMC - Flange motori IEC | *IEC Motor flanges*

CHPLB	IEC 63				IEC 71				IEC 80				IEC 90				IEC 100			
	L	Lp	P	ØD	L	Lp	P	ØD	L	Lp	P	ØD	L	Lp	P	ØD	L	Lp	P	ØD
35002	-				-				-				-				-			
35003	-				-				-				-				-			
35004	490	276	36	140	490	276	36	160	490	296	56	200	490	296	56	200	490	306	66	250

CHPLB	IEC 112				IEC 132				IEC 160				IEC 180				IEC 200				
	L	Lp	P	ØD	L	Lp	P	ØD	L	Lp	P	ØD	L	Lp	P	ØD	L	Lp	P	ØD	
35002	-				-				295	433	118	350	295	433	118	350	295	463	148	400	
35003	-				-				452				452								
35004	490	306	66	250	490	340	66	300	490	379	139										

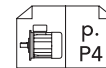
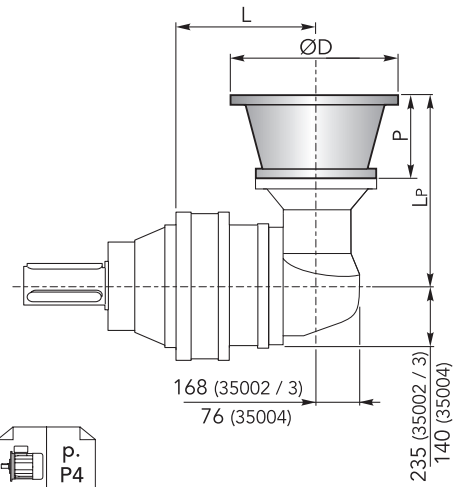

CHPLB 35000 CMC - Alberi maschi entrata | *Male input shafts*

CHPLB	CM42					CM65					CP65					
	L	Lt	T	Le	ØE	L	Lt	T	Le	ØE	L	Lt	T	Le	ØE	
35002	-					295	436.5				295	468				
35003	-					452		121.5	105	65 h6	452		153	105	65 h6	
35004	490	333	93	82	42 h6	490	377.5				490	409				

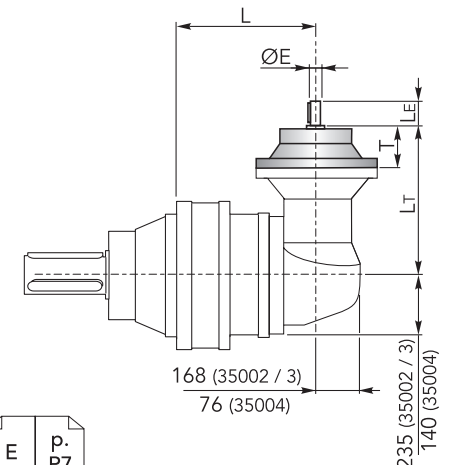

DIMENSIONI · DIMENSIONS

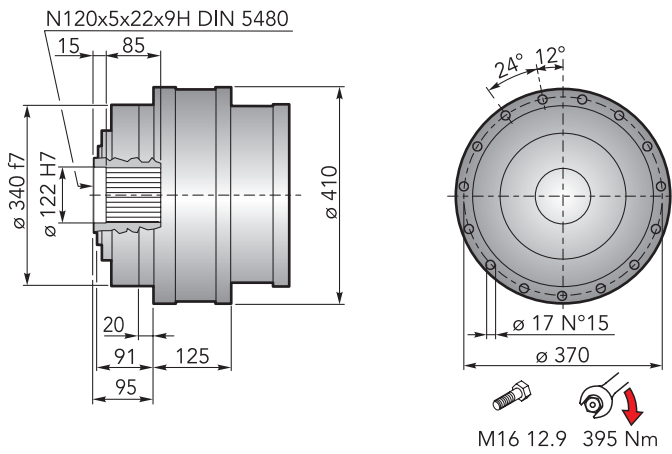

Accessori
Accessories



CHPL 35000 CF - Flange motori IEC | IEC Motor flanges

CHPL	IEC 63			IEC 71			IEC 80			IEC 90			IEC 100			IEC 112		
	Lp	P	ØD	Lp	P	ØD	Lp	P	ØD	Lp	P	ØD	Lp	P	ØD	Lp	P	ØD
35001	-	-	-	-	-	-	-	-	-	-	-	-	-	-	-	-	-	-
35002	-	-	-	-	-	-	-	-	-	-	-	-	-	-	-	-	-	-
35003	414.5	36	140	414.5	36	160	434.5	56	200	434.5	56	200	444.5	66	250	444.5	66	250
35004	475.5			475.5			495.5			495.5			505.5			505.5		

CHPL	IEC 132			IEC 160			IEC 180			IEC 200			IEC 225			IEC 250		
	Lp	P	ØD	Lp	P	ØD	Lp	P	ØD	Lp	P	ØD	Lp	P	ØD	Lp	P	ØD
35001	-	-	-	370	150	350	370	150	350	370	150	400	359	139	450	359	139	550
35002	-	-	-	425	118		425	118		455	148		-	-	-	-		
35003	478.5	100	300	517.5	139		517.5	139		-	-		-	-	-			
35004	539.5			578.5		-	-	-	-									

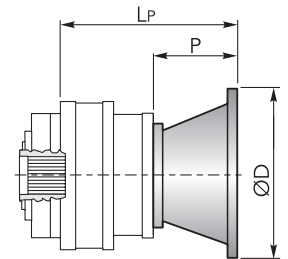

CHPL 35000 CF - Alberi maschi entrata | Male input shafts

CHPL	CM42				CM65				CP65			
	Lt	T	Le	ØE	Lt	T	Le	ØE	Lt	T	Le	ØE
35001	-	-	-	-	-	-	-	-	-	-	-	-
35002	-	-	-	-	428.5	121.5	105	65 h6	460	153	105	65 h6
35003	471.5	93	82	42 h6	513.5	-	-	-	545	-	-	-
35004	532.5				-	-	-	-	-			

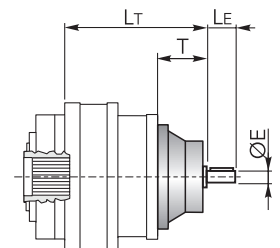



DIMENSIONI · DIMENSIONS

CHPL 35000 CF - Riduttore a vite senza fine CHM in entrata | CHM input worm gearboxes

CHPL	CHM 50					CHM 63					CHM 75				
	Lv	I	H	M	N	Lv	I	H	M	N	Lv	I	H	M	N
35001	-					-					-				
35002	-					-					-				
35003	504	50	110	60	80	513.5	63	135	72	95	492.5	75	161	86	112.5
35004	565					574.5					553.5				

CHPL	CHM 90					CHM 110					CHM 130					
	Lv	I	H	M	N	Lv	I	H	M	N	Lv	I	H	M	N	
35001	-					-					-					
35002	-					445	110	237.5	127.5	160	452	130	277.5	147.5	180	
35003	502.5	90	193	103	129.5	530					537					
35004	563.5															

CHPL	CHM 150				
	Lv	I	H	M	N
35001	-				
35002	467	150	320	170	210
35003	552				
35004	-				

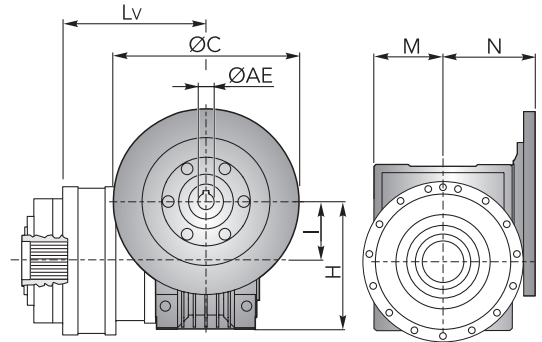

CHPLB 35000 CF - Flange motori IEC | IEC Motor flanges

CHPLB	IEC 63				IEC 71				IEC 80				IEC 90				IEC 100			
	L	Lp	P	ØD	L	Lp	P	ØD	L	Lp	P	ØD	L	Lp	P	ØD	L	Lp	P	ØD
35002	-				-				-				-				-			
35003	-				-				-				-				-			
35004	480	276	36	140	480	276	36	160	480	296	56	200	480	296	56	200	480	306	66	250

CHPLB	IEC 112				IEC 132				IEC 160				IEC 180				IEC 200				
	L	Lp	P	ØD	L	Lp	P	ØD	L	Lp	P	ØD	L	Lp	P	ØD	L	Lp	P	ØD	
35002	-				-				285	433	118	350	285	433	118	350	285	463	148	400	
35003	-				-				442				442								
35004	480	306	66	250	480	340	66	300	480	379	139										

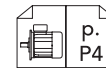
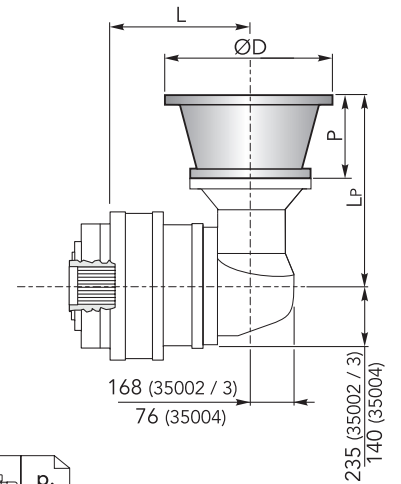

CHPLB 35000 CF - Alberi maschi entrata | Male input shafts

CHPLB	CM42					CM65					CP65				
	L	Lt	T	Le	ØE	L	Lt	T	Le	ØE	L	Lt	T	Le	ØE
35002	-					285	436.5				285	468	153	105	65 h6
35003	-					442		121.5	105	65 h6	442			105	65 h6
35004	480	333	93	82	42 h6	480	377.5				480	409			

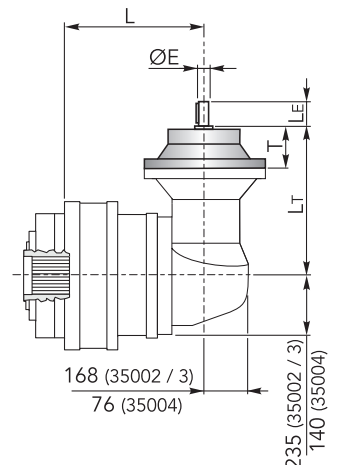

DIMENSIONI · DIMENSIONS

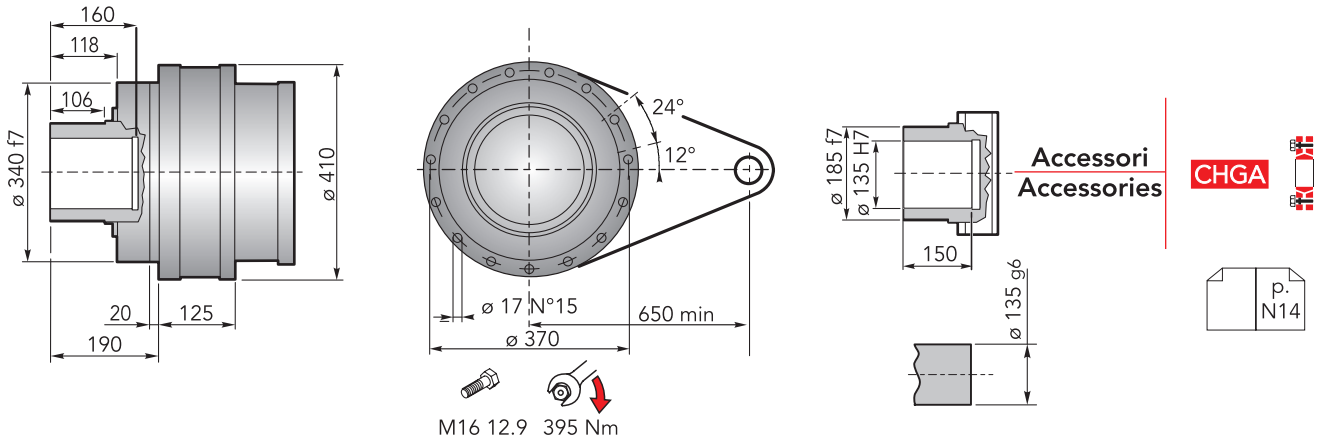

CHPL 35000 CFS - Flange motori IEC | IEC Motor flanges

CHPL	IEC 63			IEC 71			IEC 80			IEC 90			IEC 100			IEC 112		
	LP	P	ØD	LP	P	ØD	LP	P	ØD	LP	P	ØD	LP	P	ØD	LP	P	ØD
35001	-	-	-	-	-	-	-	-	-	-	-	-	-	-	-	-	-	-
35002	-	-	-	-	-	-	-	-	-	-	-	-	-	-	-	-	-	-
35003	414.5	36	140	414.5	36	160	434.5	56	200	434.5	56	200	444.5	66	250	444.5	66	250
35004	475.5			475.5			495.5			495.5			505.5			505.5		

CHPL	IEC 132			IEC 160			IEC 180			IEC 200			IEC 225			IEC 250		
	LP	P	ØD	LP	P	ØD	LP	P	ØD	LP	P	ØD	LP	P	ØD	LP	P	ØD
35001	-	-	-	370	150	-	370	150	-	370	150	400	359	139	450	359	139	550
35002	-	-	-	425	118	-	425	118	350	455	148	-	-	-	-	-	-	-
35003	478.5	100	300	517.5	139	350	517.5	139	-	-	-	-	-	-	-	-	-	-
35004	539.5			578.5			-	-	-	-	-	-	-	-	-	-	-	-

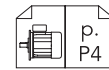
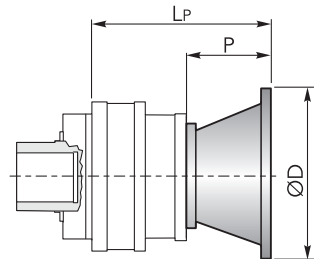

CHPL 35000 CFS - Alberi maschi entrata | Male input shafts

CHPL	CM42				CM65				CP65			
	LT	T	LE	ØE	LT	T	LE	ØE	LT	T	LE	ØE
35001	-	-	-	-	-	-	-	-	-	-	-	-
35002	-	-	-	-	428.5	121.5	105	65 h6	460	153	105	65 h6
35003	471.5	93	82	42 h6	513.5				545			
35004	532.5				-	-	-	-	-	-	-	-

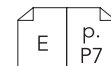
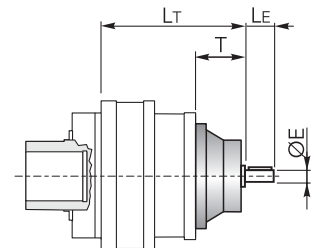



DIMENSIONI · DIMENSIONS

CHPL 35000 CFS - Riduttore a vite senza fine CHM in entrata | CHM input worm gearboxes

CHPL	CHM 50					CHM 63					CHM 75				
	Lv	I	H	M	N	Lv	I	H	M	N	Lv	I	H	M	N
35001	-					-					-				
35002	-					-					-				
35003	504	50	110	60	80	513.5	63	135	72	95	492.5	75	161	86	112.5
35004	565					574.5					553.5				

CHPL	CHM 90					CHM 110					CHM 130					
	Lv	I	H	M	N	Lv	I	H	M	N	Lv	I	H	M	N	
35001	-					-					-					
35002	-					445	110	237.5	127.5	160	452	130	277.5	147.5	180	
35003	502.5	90	193	103	129.5	530					537					
35004	563.5															

CHPL	CHM 150				
	Lv	I	H	M	N
35001	-				
35002	467	150	320	170	210
35003	552				
35004	-				

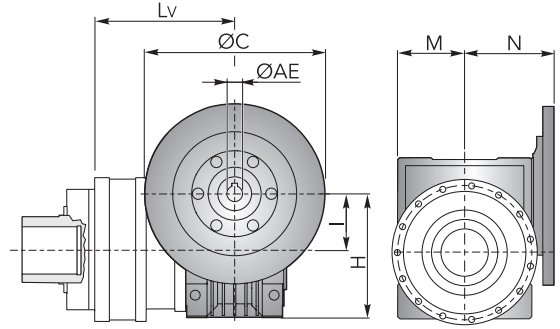

CHPLB 35000 CFS - Flange motori IEC | IEC Motor flanges

CHPLB	IEC 63				IEC 71				IEC 80				IEC 90				IEC 100			
	L	Lp	P	ØD	L	Lp	P	ØD	L	Lp	P	ØD	L	Lp	P	ØD	L	Lp	P	ØD
35002	-				-				-				-				-			
35003	-				-				-				-				-			
35004	480	276	36	140	480	276	36	160	480	296	56	200	480	296	56	200	480	306	66	250

CHPLB	IEC 112				IEC 132				IEC 160				IEC 180				IEC 200			
	L	Lp	P	ØD	L	Lp	P	ØD	L	Lp	P	ØD	L	Lp	P	ØD	L	Lp	P	ØD
35002	-				-				285	433	118	350	285	433	118	350	285	463	148	400
35003	-				-				442				442				-			
35004	480	306	66	250	480	340	66	300	480	379	139		-				-			

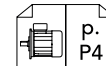
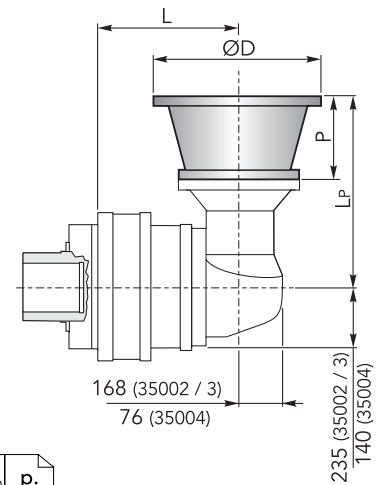

CHPLB 35000 CFS - Alberi maschi entrata | Male input shafts

CHPLB	CM42					CM65					CP65				
	L	Lt	T	Le	ØE	L	Lt	T	Le	ØE	L	Lt	T	Le	ØE
35002	-					285	436.5				285	468			
35003	-					442		121.5	105	65 h6	442		153	105	65 h6
35004	480	333	93	82	42 h6	480	377.5				480	409			

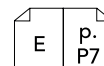
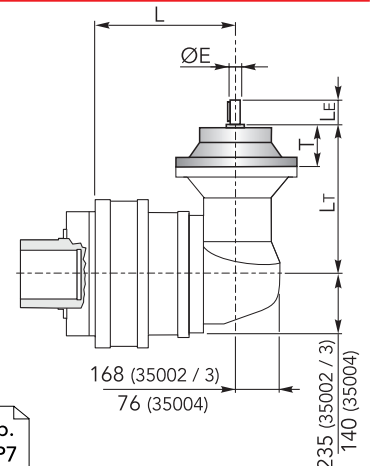

DIMENSIONI · DIMENSIONS

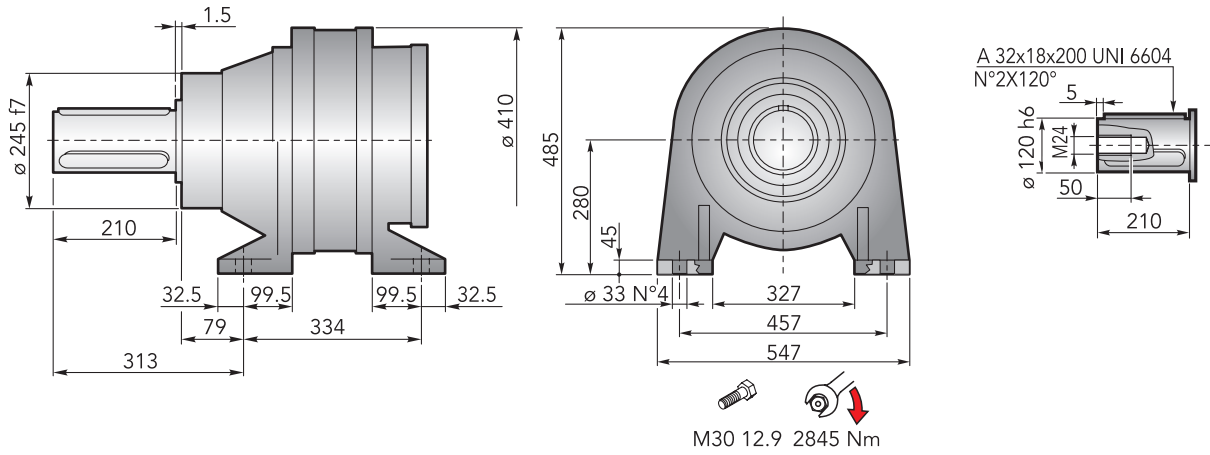

CHPL 35000 CCPC - Flange motori IEC | IEC Motor flanges

CHPL	IEC 63			IEC 71			IEC 80			IEC 90			IEC 100			IEC 112		
	LP	P	ØD	LP	P	ØD	LP	P	ØD	LP	P	ØD	LP	P	ØD	LP	P	ØD
35001	-	-	-	-	-	-	-	-	-	-	-	-	-	-	-	-	-	-
35002	-	-	-	-	-	-	-	-	-	-	-	-	-	-	-	-	-	-
35003	627	36	140	627	36	160	647	56	200	647	56	200	657	66	250	657	66	250
35004	688	36	140	688	36	160	708	56	200	708	56	200	718	66	250	718	66	250

CHPL	IEC 132			IEC 160			IEC 180			IEC 200			IEC 225			IEC 250		
	LP	P	ØD	LP	P	ØD	LP	P	ØD	LP	P	ØD	LP	P	ØD	LP	P	ØD
35001	-	-	-	582.5	150	-	582.5	150	-	582.5	150	400	571.5	139	450	571.5	139	550
35002	-	-	-	637.5	118	350	637.5	118	350	667.5	148	400	-	-	-	-	-	-
35003	691	100	300	730	139	350	730	139	350	-	-	-	-	-	-	-	-	-
35004	752	100	300	791	139	350	-	-	-	-	-	-	-	-	-	-	-	-

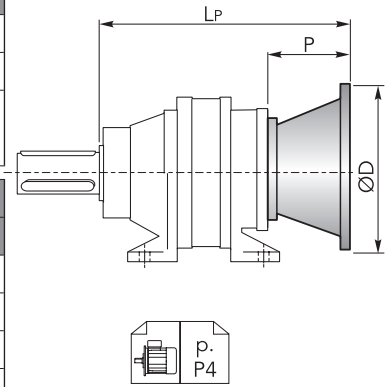

CHPL 35000 CCPC - Alberi maschi entrata | Male input shafts

CHPL	CM42				CM65				CP65			
	LT	T	LE	ØE	LT	T	LE	ØE	LT	T	LE	ØE
35001	-	-	-	-	-	-	-	-	-	-	-	-
35002	-	-	-	-	641	121.5	105	65 h6	672.5	153	105	65 h6
35003	684	93	82	42 h6	726	-	-	-	757.5	-	-	-
35004	745	-	-	-	-	-	-	-	-	-	-	-

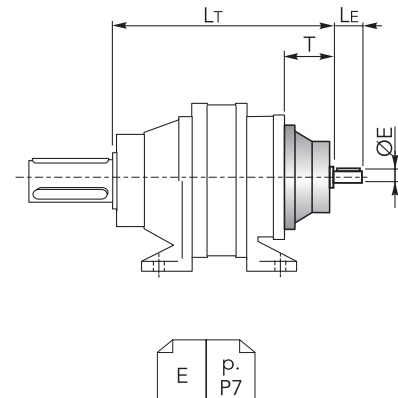



DIMENSIONI · DIMENSIONS

CHPL 35000 CCPC - Riduttore a vite senza fine CHM in entrata | CHM input worm gearboxes

CHPL	CHM 50					CHM 63					CHM 75				
	Lv	I	H	M	N	Lv	I	H	M	N	Lv	I	H	M	N
35001	-					-					-				
35002	-					-					-				
35003	716.5	50	110	60	80	726	63	135	72	95	705	75	161	86	112.5
35004	777.5					787					766				

CHPL	CHM 90					CHM 110					CHM 130					
	Lv	I	H	M	N	Lv	I	H	M	N	Lv	I	H	M	N	
35001	-					-					-					
35002	-					657.5	110	237.5	127.5	160	664.5	130	277.5	147.5	180	
35003	715	90	193	103	129.5	742.5					749.5					
35004	776															

CHPL	CHM 150				
	Lv	I	H	M	N
35001	-				
35002	679.5	150	320	170	210
35003	764.5				
35004	-				

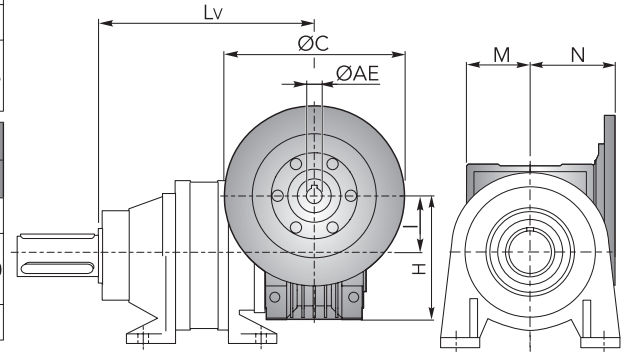

ØC p.
 ØAE P6

CHPL / CHPLB 35000 CCPC

CHPLB 35000 CCPC - Flange motori IEC | IEC Motor flanges

CHPLB	IEC 63				IEC 71				IEC 80				IEC 90				IEC 100			
	L	Lp	P	ØD	L	Lp	P	ØD	L	Lp	P	ØD	L	Lp	P	ØD	L	Lp	P	ØD
35002	-				-				-				-				-			
35003	-				-				-				-				-			
35004	692.5	276	36	140	692.5	276	36	160	692.5	296	56	200	692.5	296	56	200	692.5	306	66	250

CHPLB	IEC 112				IEC 132				IEC 160				IEC 180				IEC 200			
	L	Lp	P	ØD	L	Lp	P	ØD	L	Lp	P	ØD	L	Lp	P	ØD	L	Lp	P	ØD
35002	-				-				497.5	433	118	350	497.5	433	118	350	497.5	463	148	400
35003	-				-				654.5				654.5							
35004	692.5	306	66	250	692.5	340	66	300	692.5	379	139									

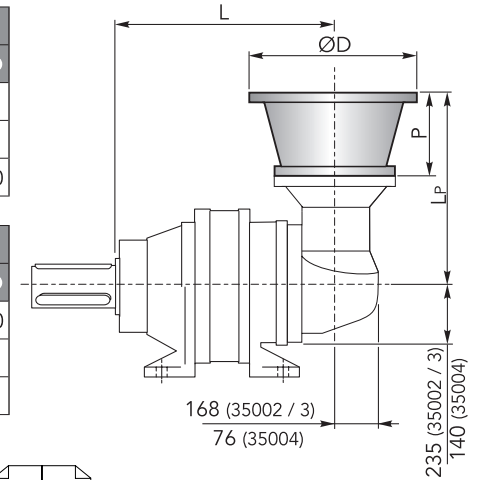

p.
 P4

CHPLB 35000 CCPC - Alberi maschi entrata | Male input shafts

CHPLB	CM42					CM65					CP65				
	L	Lt	T	Le	ØE	L	Lt	T	Le	ØE	L	Lt	T	Le	ØE
35002	-					497.5	436.5				497.5	468	153	105	65 h6
35003	-					654.5		121.5	105	65 h6	654.5			105	65 h6
35004	692.5	333	93	82	42 h6	692.5	377.5			692.5	409				

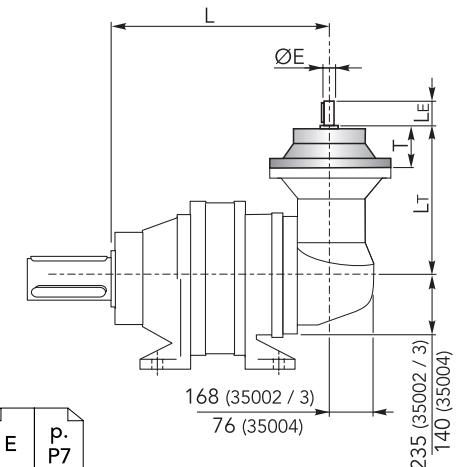

E p.
 P7



CARICHI RADIALI (Fr) · RADIAL LOADS (Fr)

Nel diagramma seguente, sono indicati i carichi radiali Fr (N) applicabili sull'albero uscita in funzione della distanza di applicazione L rispetto alla battuta dell'albero.

The hereunder table shows the allowable radial loads Fr (N) on the output shaft with reference to the distance L .

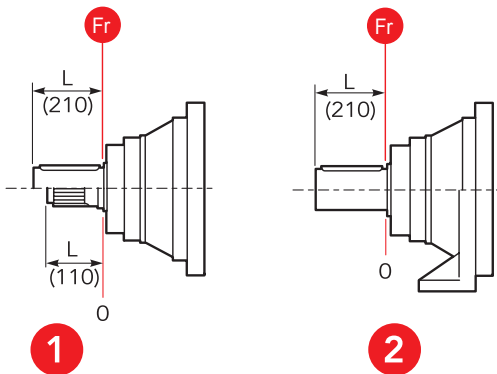
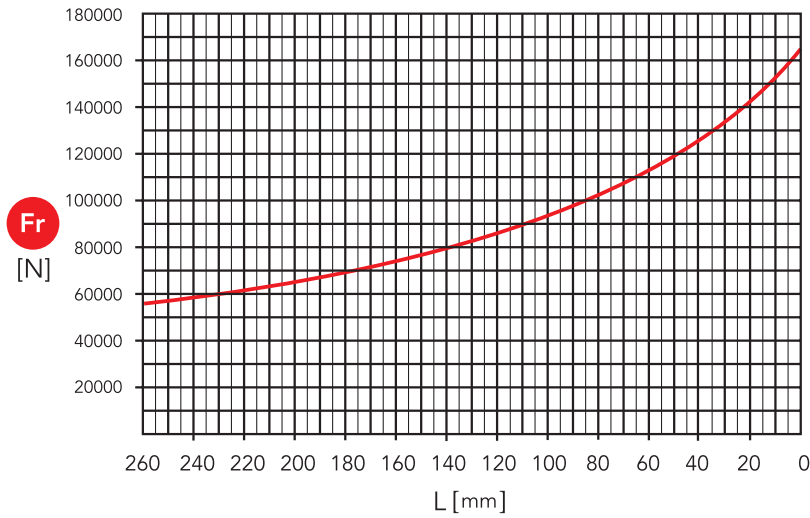

- 1 Uscita / Output: CMS, CMC
- 2 Uscita / Output: CCPC

CARICHI ASSIALI (Fa) · AXIAL LOADS (Fa)

Nella tabella seguente sono indicati i carichi assiali Fa (N) applicabili sull'albero di uscita in funzione della direzione di applicazione del carico e della versione.

The hereunder table shows the allowable axial loads Fa (N) on the output shaft with reference to the load direction and the output type.

	1	2	
Fa [N]	80000	80000	←
	100000	100000	→

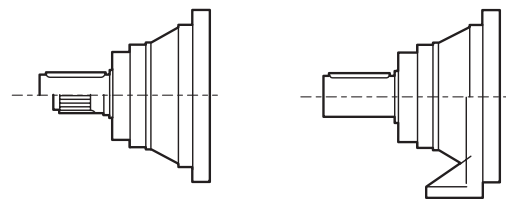

- 1 Uscita / Output: CMS, CMC
- 2 Uscita / Output: CCPC

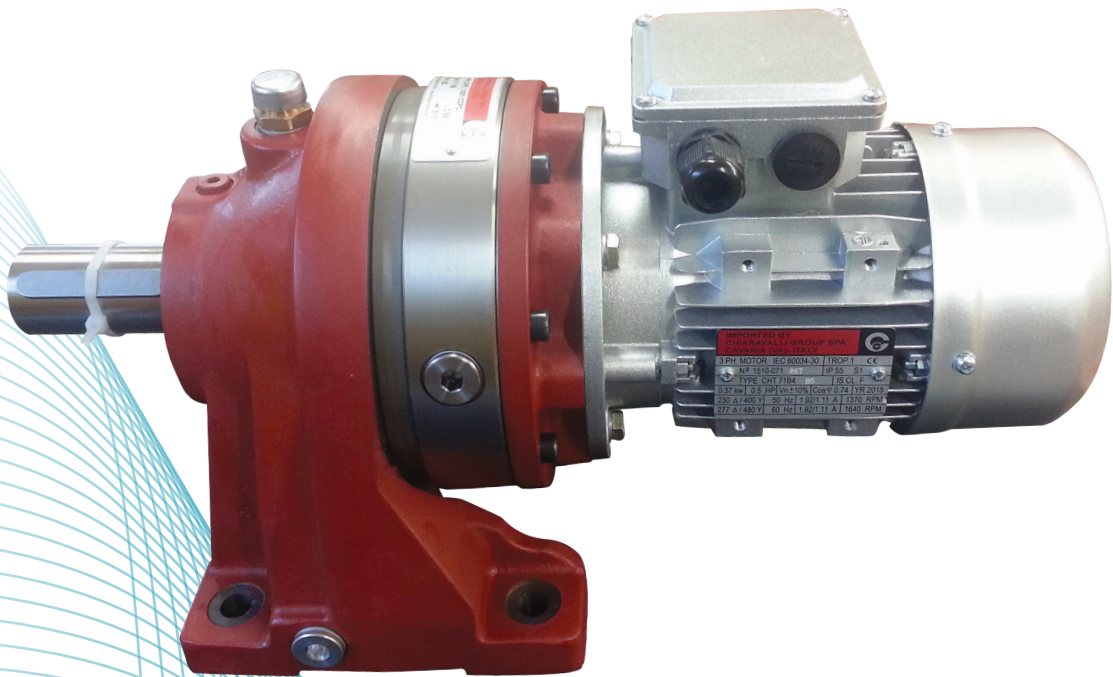



MOTORI ELETTRICI · ELECTRIC MOTORS

CHIARAVALLI può fornire ai suoi clienti differenti motorizzazioni elettriche installabili sui riduttori epicicloidali lineari/angolari o sui combinati vite senza fine.

Tutti i nostri motori sono forniti con grado di protezione IP55, classe di isolamento F e separatore di fase per l'utilizzo sotto inverter, in questo caso possono essere forniti completi di servoventilazione.

CHIARAVALLI Group S.p.A. can supply different electric motorizations to its customers which can be mounted on the planetary, linear/ angular gearboxes or on double worm gearboxes. All our motors are supplied with level of protection IP55 insulation class F and phase separator to be used under frequency variator and in this case can be supplied complete with forced ventilation.

Principali caratteristiche motori elettrici Chiaravalli

- Motori con rotore a gabbia, chiusi con ventilazione superficiale esterna.
- Progetto, costruzione e collaudo in conformità alle norme CEI2-3, norme internazionali IEC 34-1 ed alle principali norme straniere.
- Potenze-dimensioni secondo le norme IEC 72, norme nazionali UNEL-MEC.
- Classe isolamento F.
- Protezione IP55.
- Servizio continuo S1.
- Direttiva Europea ROHS 2002/95/CE.
- Separatori di fase.
- A richiesta motori da 160 a 355.
- Volt 400/690 standard da 160 a 355 a richiesta sugli altri.

Main characteristics Chiaravalli electric motors

- Motors with cage rotor, closed with external surface ventilation/ fan cooled ventilation
- Project, manufacturing and testing in accordance with CEI2-3 regulations, IEC 34-1 international regulation and with main foreign regulation.
- Power and dimensions in accordance with IEC 72 and national UNEL-MEC regulations.
- Insulation class F
- Protection IP55
- S1 continuous service
- ROHS 2002/95/CE European Directive
- Phase separators
- Motors from 160 to 355
- Voltage 400/690 standard on motors from 160 to 355 on demand for the others

Simbologia

Symbols

n	[rpm]	Velocità di rotazione	Rotation speed
P_n	[kW]	Potenza nominale	Nominal power
M_n	[Nm]	Coppia nominale	Nominal torque
I_n	[A]	Corrente nominale	Nominal current
I_s	[A]	Corrente di spunto	Starting current
M_s	[Nm]	Coppia di spunto	Starting torque
M_{max}	[Nm]	Coppia massima	Max torque
V	[V]	Tensione	Voltage
V_p	[V]	Tensione di targa	Plate voltage
F	[Hz]	Frequenza	Frequency
CosØ		Fattore di potenza	Power factor
C	[µF]	Capacità del condensatore	Capacitor
η	[%]	Rendimento	Efficiency
Fr	[N]	Carico radiale	Radial load

MOTORI ELETTRICI · ELECTRIC MOTORS

Funzionamento a 60 Hz

I motori CHIARAVALLI possono funzionare con frequenza a 60 Hz con differenze di prestazione e grandezze elettriche applicando i coefficienti moltiplicativi indicati nella tabella.

Operation at 60 Hz

CHIARAVALLI motors can work at 60 Hz frequency with different performances and electrical size as described on the following chart.

Coefficienti di conversione per funzionamento da 50 Hz a 60 Hz / Conversion coefficient for function from 50 Hz to 60 Hz								
V _p (50 Hz) [V]	V _p (60 Hz) [V]	P _n [kW]	I _n [A]	M _n [Nm]	n [rpm]	I _s [A]	M _s [Nm]	M _{max} [Nm]
230 +/- 10%	220 +/- 5%	1	1	0.83	1.2	0.83	0.83	0.83
230 +/- 10%	230 +/- 10%	1	0.95	0.83	1.2	0.83	0.83	0.83
230 +/- 10%	254 +/- 5%	1.15	1.02	0.96	1.2	0.93	0.93	0.93
230 +/- 10%	277 +/- 5%	1.2	1	1	1.2	1	1	1
400 +/- 10%	380 +/- 5%	1	1	0.83	1.2	0.83	0.83	0.83
400 +/- 10%	400 +/- 10%	1	0.95	0.83	1.2	0.83	0.83	0.83
400 +/- 10%	440 +/- 5%	1.16	1.02	0.96	1.2	0.93	0.93	0.93
400 +/- 10%	460 +/- 10%	1.15	1	0.96	1.2	0.96	0.96	0.96
400 +/- 10%	480 +/- 5%	1.2	1	1	1.2	1	1	1

Tensione di alimentazione

I motori CHIARAVALLI sono progettati per essere utilizzati sulla rete Europea 230/400 Volt +/- 10% - 50 Hz e 400/690 +/- 10% - 50 Hz.

Questo significa che lo stesso motore può funzionare sulle seguenti reti ancora esistenti:

- 220/380 Volt +/- 5%
- 230/400 Volt +/- 10%
- 240/415 Volt +/- 5%
- 380/660 Volt +/- 5%
- 400/690 Volt +/- 10%
- 415/720 Volt +/- 5%

rispondendo ai requisiti richiesti dalle normative di numerosi paesi.

Power voltage

CHIARAVALLI motors are configured to be used all over the European net system 230/440 Volt +/-10% -50Hz and 400/690 +/-10%-50Hz

This means that the same motor can be used on the following existing network:

- 220/380 Volt +/- 5%
- 230/400 Volt +/- 10%
- 240/415 Volt +/- 5%
- 380/660 Volt +/- 5%
- 400/690 Volt +/- 10%
- 415/720 Volt +/- 5%

answering to the required standard conditions in many countries.



IE 1

CARATTERISTICHE TECNICHE ELETTRICHE · ELECTRIC TECHNICAL CHARACTERISTICS

TIPO TYPE		POLI POLES	POTENZA POWER Kw	TENSIONE VOLTAGE V	CORRENTE CURRENT 400 V	COPPIA TORQUE N/m	RENDIMENTO EFFICIENCY %	FATTORE FACTOR COS.φ	PESO WEIGHT Kg.
CHT 56	B2	2	0.13	230/400	0.40	0.42	62.00	0.69	3.20
CHT 56	B4	4	0.09	230/400	0.43	0.64	50.00	0.61	3.20
CHT 63	A2	2	0.18	230/400	0.55	0.63	63.00	0.75	4.00
CHT 63	B2	2	0.25	230/400	0.71	0.88	65.00	0.78	4.40
CHT 63	C2	2	0.37	230/400	1.05	1.30	65.00	0.78	4.90
CHT 63	A4	4	0.12	230/400	0.47	0.85	57.00	0.64	3.90
CHT 63	B4	4	0.18	230/400	0.70	1.27	57.00	0.65	4.50
CHT 63	C4	4	0.22	230/400	0.92	1.77	59.00	0.67	4.80
CHT 63	B6	6	0.12	230/400	0.62	1.27	45.00	0.62	4.80
CHT 71	A2	2	0.37	230/400	0.97	1.29	70.00	0.79	5.60
CHT 71	B2	2	0.55	230/400	1.42	1.90	71.00	0.79	6.10
CHT 71	A4	4	0.25	230/400	0.84	1.77	60.00	0.62	5.60
CHT 71	B4	4	0.37	230/400	1.12	2.58	65.00	0.74	6.20
CHT 71	C4	4	0.55	230/400	1.61	3.81	66.00	0.75	7.00
CHT 71	A6	6	0.18	230/400	0.70	1.95	56.00	0.66	6.00
CHT 71	B6	6	0.25	230/400	0.87	2.65	59.00	0.70	6.50
CHT 71	C6	6	0.37	230/400	1.27	3.97	61.00	0.69	7.20
CHT 80	A4	4	0.55	230/400	1.59	3.81	67.00	0.75	8.90
CHT 80	A6	6	0.37	230/400	1.23	3.93	62.00	0.70	8.20
CHT 80	B6	6	0.55	230/400	1.65	5.80	67.00	0.72	9.90

IE 2

CHT 80	A2	2	0.75	230/400	1.75	2.51	77.40	0.80	9.10
CHT 80	B2	2	1.10	230/400	2.45	3.69	80.00	0.82	10.70
CHT 80	C2	2	1.50	230/400	3.12	4.97	82.70	0.83	13.00
CHT 80	B4	4	0.75	230/400	1.79	5.04	79.60	0.76	11.20
CHT 80	C4	4	1.10	230/400	2.72	7.39	81.40	0.71	13.50
CHT 90	S2	2	1.50	230/400	3.20	4.95	81.40	0.83	13.30
CHT 90	L2	2	2.20	230/400	4.54	7.38	83.20	0.84	16.00
CHT 90	S4	4	1.10	230/400	2.50	7.37	81.40	0.78	13.90
CHT 90	L4	4	1.50	230/400	3.31	10.09	82.80	0.79	16.20
CHT 90	M4	4	2.20	230/400	5.09	14.71	84.30	0.74	20.50
CHT 90	S6	6	0.75	230/400	2.01	7.66	76.00	0.71	13.00
CHT 90	L6	6	1.10	230/400	2.82	11.23	78.10	0.72	16.30
CHT 100	LA2	2	3.00	230/400	5.88	10.05	84.60	0.87	23.00
CHT 100	LA4	4	2.20	230/400	4.83	14.70	84.30	0.78	22.70
CHT 100	LB4	4	3.00	230/400	6.33	20.00	85.50	0.80	26.50
CHT 100	LA6	6	1.50	230/400	3.71	15.20	80.00	0.73	22.00
CHT 112	M2	2	4.00	230/400	7.56	13.13	86.00	0.89	27.00
CHT 112	M4	4	4.00	230/400	8.23	26.60	86.60	0.81	32.50
CHT 112	L4	4	5.50	230/400	11.25	36.57	87.90	0.80	39.00
CHT 112	M6	6	2.20	230/400	5.17	22.30	81.80	0.75	29.50
CHT 132	SA2	2	5.50	230/400	10.25	18.00	87.20	0.89	40.20
CHT 132	SB2	2	7.50	230/400	13.80	24.47	88.10	0.89	45.00
CHT 132	S4	4	5.50	230/400	11.00	36.22	87.90	0.83	44.00
CHT 132	M4	4	7.50	230/400	14.50	50.00	88.70	0.84	53.50
CHT 132	M6	6	4.00	230/400	8.86	40.42	84.60	0.77	45.00
CHT 132	S6	6	3.00	230/400	6.84	30.48	83.30	0.76	36.10

IE 3

TIPO TYPE	POLI POLES	POTENZA POWER Kw	TENSIONE VOLTAGE V	CORRENTE CURRENT 400 V	COPPIA TORQUE N/m	RENDIMENTO EFFICIENCY %	FATTORE FACTOR COS.φ	PESO WEIGHT Kg.
CHT 80 A2	2	0.75	230/400	1.66	2.51	80.7	0.81	8.5/8.4
CHT 80 B2	2	1.1	230/400	2.31	3.69	82.7	0.83	10.3/10.2
CHT 90 S2	2	1.5	230/400	3.14	5.02	84.2	0.82	14.4/14.3
CHT 90 L2	2	2.2	230/400	4.51	7.38	85.9	0.82	16.3/16.1
CHT 100 LA2	2	3	230/400	5.59	10.05	87.1	0.89	24.1/24.0
CHT 112 M2	2	4	230/400	7.2	13.13	88.1	0.91	30.2/30.1
CHT 132 SA2	2	5.5	230/400	10	18.08	89.2	0.89	44.2/44.00
CHT 132 SB2	2	7.5	230/400	13.4	24.61	90.1	0.90	52.0/52.8
CHT 80 B4	4	0.75	230/400	1.9	5.04	82.2	0.69	12.1/11.3
CHT 90 S4	4	1.1	230/400	2.59	7.37	84.1	0.73	15.0/15.0
CHT 90 L4	4	1.5	230/400	3.43	10.09	85.3	0.74	18.0/18.0
CHT 100 LA4	4	2.2	230/400	4.58	14.69	86.7	0.80	23.5/23.0
CHT 100 LB4	4	3	230/400	6.33	20.03	87.7	0.78	28.2/28.0
CHT 112 M4	4	4	230/400	7.95	26.62	88.6	0.82	32.3/32.0
CHT 132 S4	4	5.5	230/400	10.5	36.73	89.6	0.84	48.0/47.5
CHT 132 M4	4	7.5	230/400	14.3	50.08	90.4	0.84	58.2/58.0
CHT 90 S6	6	0.75	230/400	2.05	7.66	78.9	0.67	14.1/14.0
CHT 10 L6	6	1.1	230/400	2.93	11.23	81.0	0.67	17.8/16.2
CHT 100 LA6	6	1.5	230/400	3.75	15.24	82.5	0.70	22.2/22.0
CHT 112 M6	6	2.2	230/400	5.54	22.35	84.3	0.68	27.0/26.0
CHT 132 S6	6	3	230/400	6.84	30.48	86.8	0.74	40.0/39.0
CHT 132 MA6	6	4	230/400	8.99	40.42	86.8	0.74	47.5/47.2
CHT 132 MB6	6	5.5	230/400	12.7	55.58	88.0	0.71	55.4/54.0

MOTORI EFFICIENZA IE 3

Il 1° Gennaio 2017 è entrata in vigore la terza fase del regolamento (CE) n° 640/2009 pertanto, a partire dalla suddetta data, i motori commercializzati nello Spazio Economico Europeo a 2, 4 e 6 poli con potenza compresa tra 0,75 Kw e 375 Kw dovranno avere efficienza minima IE3, in alternativa IE2, se alimentati da convertitore di frequenza (inverter) oppure destinati a paesi non appartenenti al suddetto mercato.

Con l'entrata in vigore della terza fase sarà responsabilità dell'acquirente assicurarsi che i motori IE2, rientranti nella normativa, siano utilizzati come sopra indicato.

- * A richiesta motori da 160 a 355
- * Volt 400/690 standard da 160 a 355 a richiesta sugli altri
- * A richiesta è fornibile motore marca **SIEMENS**
- * A richiesta è fornibile motore autofrenante marca **MGM**

IE 3 EFFICIENCY MOTORS

From January 2017, the third phase of the regulation (CE) n° 640/2009 came into force, therefore, starting from this date, the electric motors sold in the European Economic Market at 2, 4 and 6 poles with power included between KW 0,75 and KW 375 Kw must have minimum efficiency IE3, alternatively IE2, if supplied with inverter or destined for countries not belonging to the aforementioned market.

With the entry into force of the third phase, it will be the responsibility of the purchaser to make sure that the IE2 motors, which are included in the regulations, are used as indicated above.

- * Motors size 160 up to 355 on request
- * Volt 400/690 standard from 160 up to 355 on request for other sizes.
- * **SIEMENS** motor available on request
- * **MGM** brake motor available on request



B5

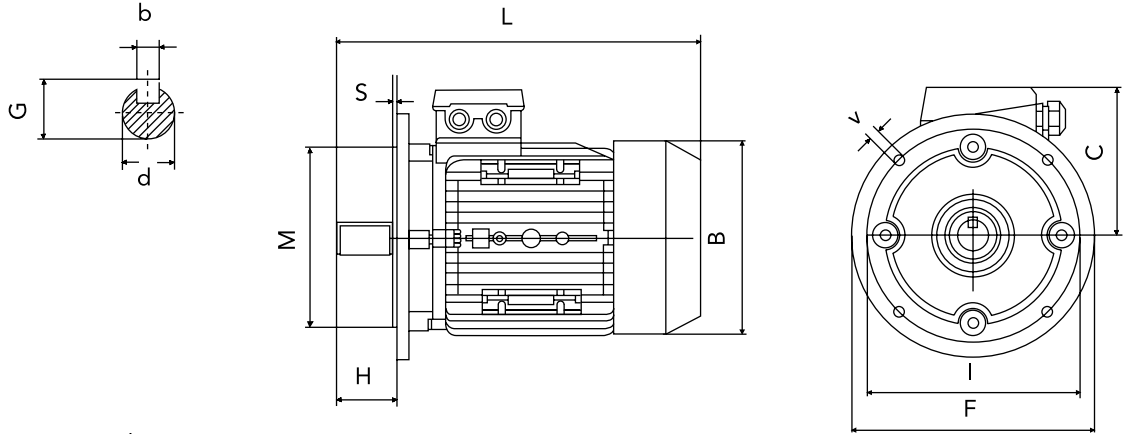

B14

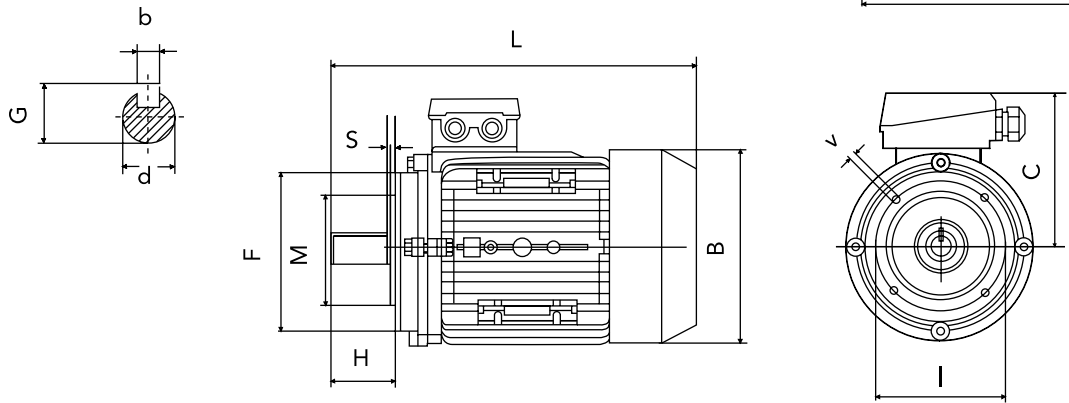

B3

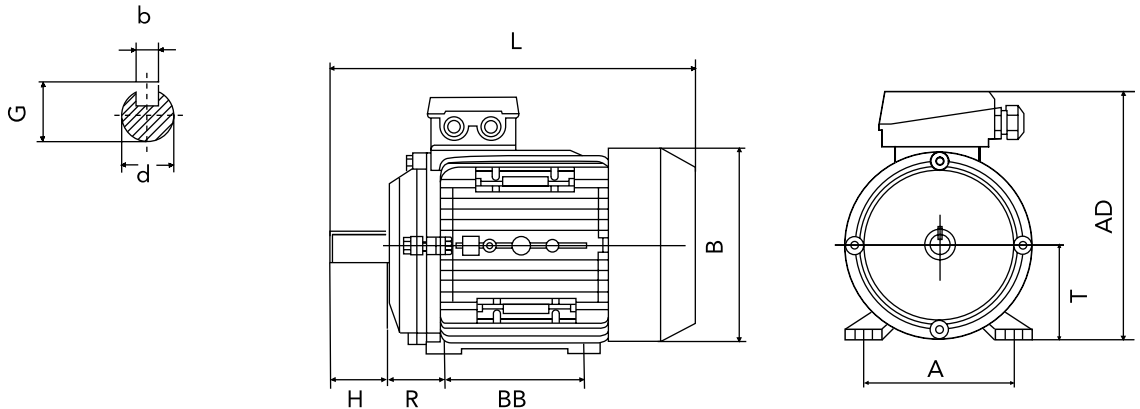

DIMENSIONI E INGOMBRI | SIZES AND DIMENSIONS

TIPO TYPE	DIMENSIONI DI MONTAGGIO (mm) MOUNTING DIMENSIONS (mm)															INGOMBRI DIMENSIONS						
	B5					B14					B3					B	C	L				
d	H	b	G	I	M	F	v	S	I	M	F	v	R	BB	A				T	AD		
56	9	20	3	10.2	100	80	120	7	3.0	65	50	80	M5	2.5	36	71	90	56	156	110	100	195
63	11	23	4	12.5	115	95	140	10	3.0	75	60	90	M5	2.5	40	80	100	63	173	123	110	215
71	14	30	5	16	130	110	160	10	3.5	85	70	105	M6	2.5	45	90	112	71	188	138	117	255
80	19	40	6	21.5	165	130	200	12	3.5	100	80	120	M6	3.0	50	100	125	80	217	155	137	290
90S	24	50	8	27	165	130	200	12	3.5	115	95	140	M8	3.0	56	100	140	90	235	176	145	310
90L/90LL	24	50	8	27	165	130	200	12	3.5	115	95	140	M8	3.0	56	125	140	90	235	176	145	335
100L	28	60	8	31	215	180	250	15	4.0	130	110	160	M8	3.5	63	140	160	100	252	197	152	386
112M	28	60	8	31	215	180	250	15	4.0	130	110	160	M8	3.5	70	140	190	112	292	220	180	395
132S	38	80	10	41	265	230	300	15	4.0	165	130	200	M10	4.0	89	140	216	132	325	257	195	436
132M	38	80	10	41	265	230	300	15	4.0	165	130	200	M10	4.0	89	178	216	132	325	257	195	475

Le misure sono indicative | The dimensions are indicative.

KIT SERVOVENTILATO* SERIE MONOFASE

FORCED VENTILATION KIT* SINGLE-PHASE MODELS

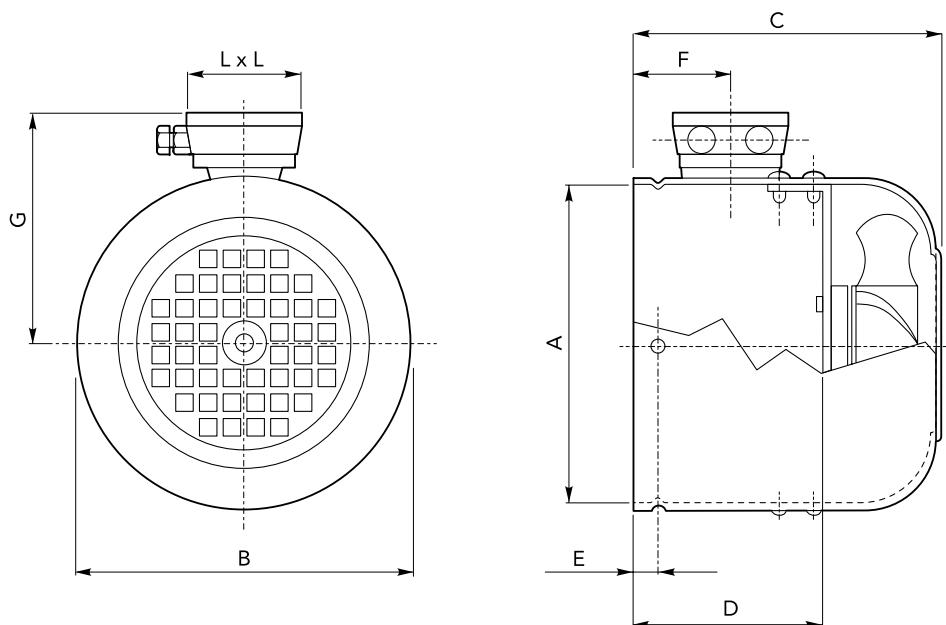

Ingombri monofasi con morsetteria IP55
Dimension of single phase motors with IP55 terminal board.

A richiesta fornibili in trifase 400 Vac
Forced ventilation kit three-phase models available on request.

GRAND. SIZE	VOLT VOLTAGE	HZ	VELOC. NOM. MIN/1 NOM. SPEED MIN/1	ASSORB. WATT ABSORB. WATT	CORRENT M.A. CURRENT M.A.	PORT. ARIA M 3/H AIR FLOW M 3/H
GR.63	230	50 / 60	2750	15 / 14	120 / 100	180
GR.71	230	50 / 60	2750	15 / 14	120 / 100	180
GR.80	230	50 / 60	2750	15 / 14	120 / 100	180
GR.90	230	50 / 60	2900	42 / 36	190 / 180	340
GR.100	230	50 / 60	2900	42 / 36	190 / 180	340
GR.112	230	50 / 60	2900	42 / 36	190 / 180	340
GR.132	230	50 / 60	2900	42 / 36	190 / 180	340

GRAND. SIZE	COD. IP55	A	B	C	D	E	F	G	L x L
GR.63	AS063230	121	123	102	58	6	50	104	75
GR.71	AS071230	136	138	120	70	6	50	111	75
GR.80	AS080230	153	155	130	80	6	55	125	100
GR.90	AS090230	172	176	145	75	6	60	135	100
GR.100	AS100230	195	197	158	85	8	60	150	100
GR.112	AS112230	218	220	160	100	10	60	160	100
GR.132	AS132230	255	257	180	120	8	65	175	100

* kit servoventilato serie trifase a richiesta

* forced ventilation kit three-phase models available on request



Per servoventilazione su taglie superiori alla 132, contattare il servizio tecnico CHIARAVALLI.
For forced ventilation of sizes over 132 please contact our technical service CHIARAVALLI.



FORNIBILI CON MOTORI ORBITALI AVAILABLE WITH ORBITAL MOTORS

P7

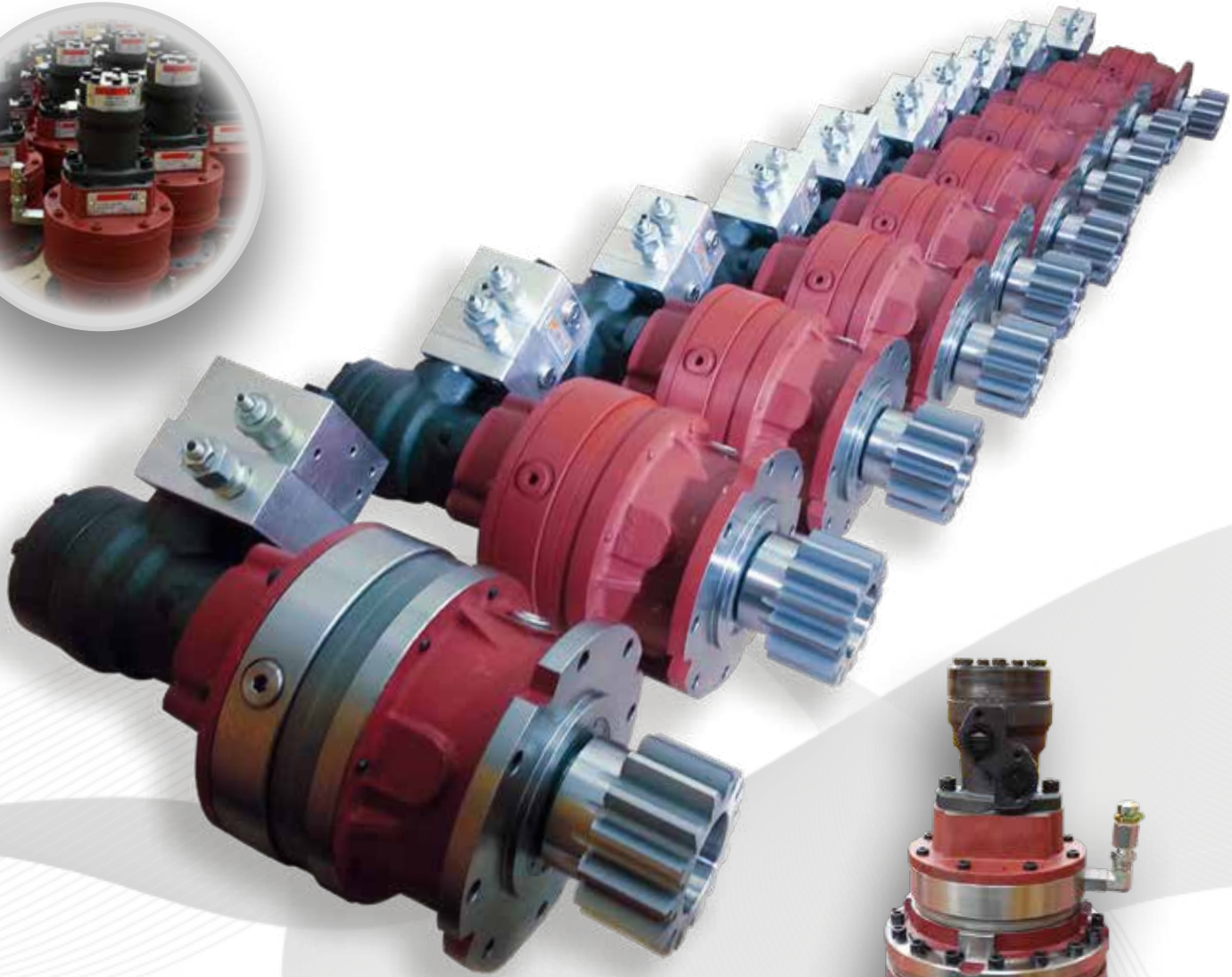

PREDISPOSIZIONI PER RIDUTTORI A VITE SENZA FINE · WORM GEAR CONNECTIONS

CHIARAVALLI può fornire ai suoi clienti riduttori epicicloidali combinati ai vite senza fine della serie CHM CHIARAVALLI. Per la selezione del riduttore a vite senza fine contattare il servizio tecnico CHIARAVALLI.

Il vite senza fine è installabile sulla versione lineare CHPL con il duplice scopo di:

- rendere l'ingresso ortogonale rispetto all'uscita dell'epicicloidale
- aumentare il rapporto di riduzione

Di seguito riportiamo le diverse predisposizioni attacco motore per i vite senza fine:

CHIARAVALLI can supply combined planetary gearboxes with worm gear of CHM CHIARAVALLI series to its customers. In order to choose the correct gearbox with worm gear connections, please contact CHIARAVALLI technical service.

The worm gearbox connection can be installed on the linear version CHPL with the double aim of:

- Have an orthogonal input and an planetary output
- Increase the ratio

Here following the different input motor adaptor for worm gear connections:

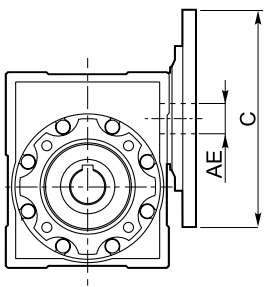

IEC su riduttori a vite senza fine CHM / IEC flnges on CHM worm gearboxes													
Taglia VSF VSF size	i											ØC	ØAE
	7.5	10	15	20	25	30	40	50	60	80	100		
	IEC disponibili su vite senza fine / IEC wormgear available												
CHM 050	80	80	80	80	80	80	80	-	-	-	-	B5 200 B14 124	19
	71	71	71	71	71	71	71	71	71	71	71	B5 160 B14 105	14
	-	-	-	-	-	-	63	63	63	63	63	B5 140	11
CHM 063	90	90	90	90	90	90	-	-	-	-	-	B5 200 B14 140	24
	80	80	80	80	80	80	80	80	80	80	-	B5 200 B14 120	19
	-	-	-	-	-	-	71	71	71	71	71	B5 160 B14 105	14
CHM 075	100 112	100 112	100 112	-	-	-	-	-	-	-	-	B5 250 B14 160	28
	90	90	90	90	90	90	90	90	-	-	-	B5 200 B14 140	24
	-	-	-	80	80	80	80	80	80	80	80	B5 200 B14 120	19
	-	-	-	-	-	-	-	71	71	71	71	B5 160	14
CHM 090	100 112	100 112	100 112	100 112	100 112	100 112	-	-	-	-	-	B5 250 B14 160	28
	90	90	90	90	90	90	90	90	90	-	-	B5 200 B14 140	24
	-	-	-	-	-	-	80	80	80	80	80	B5 200 B14 120	19
CHM 110	132	132	132	132	-	-	-	-	-	-	-	B5 300 B14 200	38
	100 112	100 112	100 112	100 112	100 112	100 112	100 112	100 112	100 112	-	-	B5 250 B14 160	28
	-	-	-	-	-	-	90	90	90	90	90	B5 200	24
CHM 130	132	132	132	132	132	132	132	-	-	-	-	B5 300 B14 200	38
	-	-	-	-	-	100 112	100 112	100 112	100 112	100 112	100 112	B5 250 B14 160	28
	-	-	-	-	-	-	-	-	-	90	90	B5 200	24
CHM 150	160	160	160	160	160	-	-	-	-	-	-	B5 350	42
	-	-	-	-	-	132	132	132	132	-	-	B5 300	38
	-	-	-	-	-	-	-	-	-	100 112	100 112	B5 250	28



ALBERI MASCHIO IN ENTRATA · MALE INPUT SHAFTS

CHIARAVALLI può fornire ai suoi clienti diverse tipologie di alberi maschio in entrata.

CHIARAVALLI can supply different kind of male input shaft to its customers.

Dimensioni / Dimensions

Carichi radiali / Radial loads

CM42

kg 9.0

NO HOLE

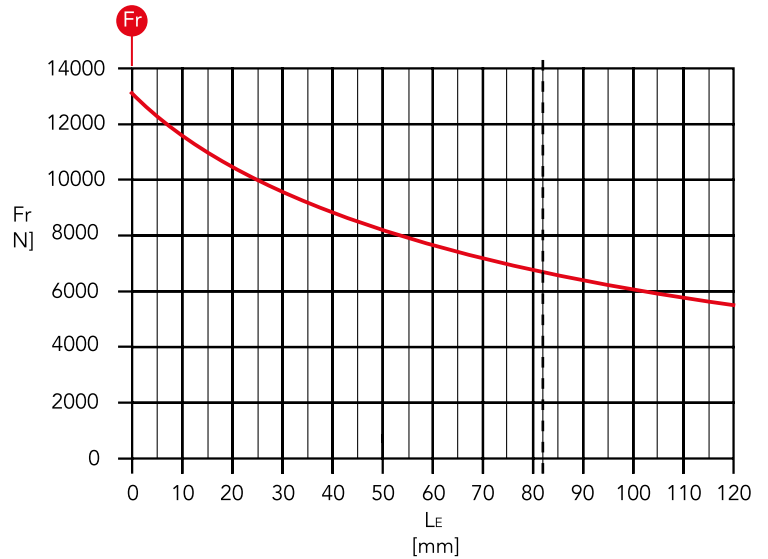
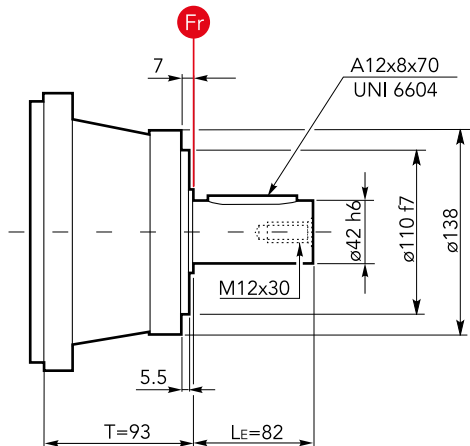

CM65

kg 17.0

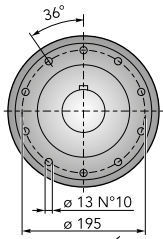

M12 10.9 119 Nm

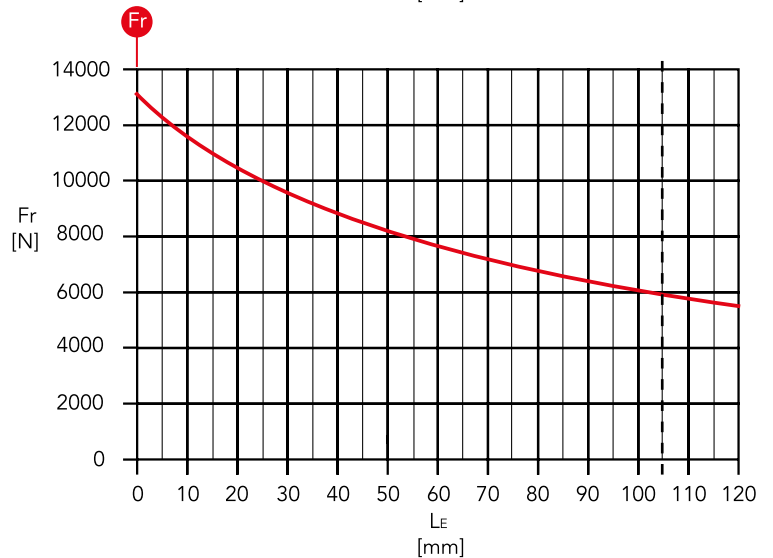
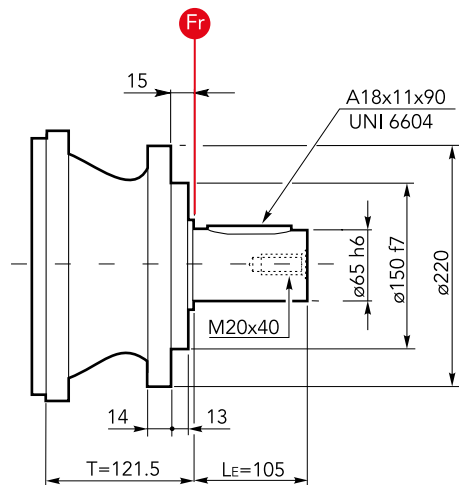

CP65

kg 26.0

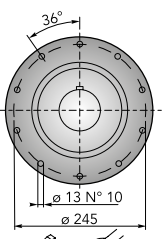

M12 8.8 96.9 Nm

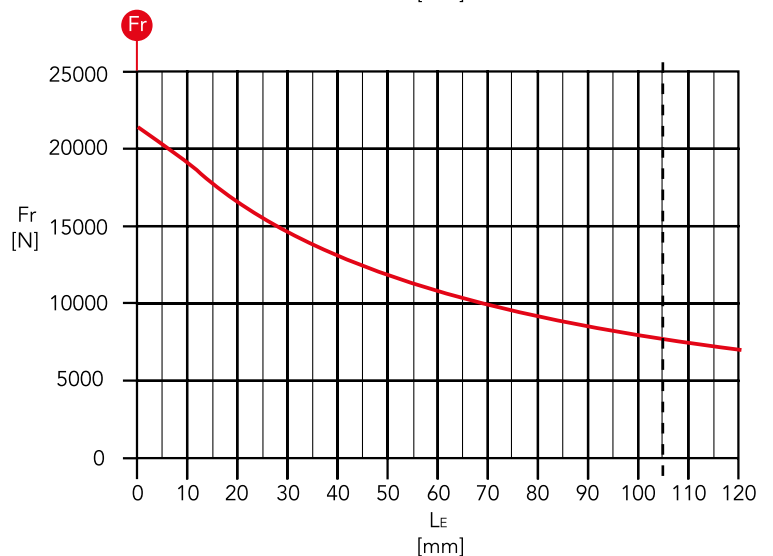
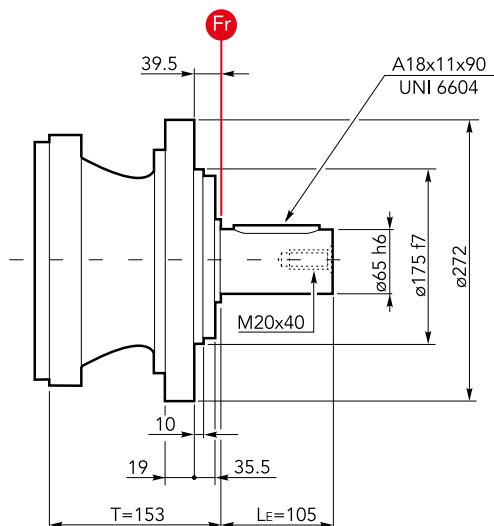

PREDISPOSIZIONI PER MOTORI IDRAULICI · HYDRAULIC MOTORS CONNECTION

CHIARAVALLI può offrire ai suoi clienti le predisposizioni per i più diffusi motori idraulici.

Di seguito riportiamo gli ingressi disponibili.

Per ogni altra necessità non in tabella contattare il Servizio Tecnico CHIARAVALLI.

CHIARAVALLI can offer input motor adaptor for the most hydraulic motor.

Following the available input adaptor. For any other requirement not listed in the chart here following, please contact technical service CHIARAVALLI.

	Tipo motore / Motor type	Codice / Code
DINAMIC OIL	AH100/BH150/BH175/BH200 28x34 UNI 8953	2074.013.024
	PH800 46x50 UNI 8953	2074.053.020
	PH250/PH300 32x38 UNI 8953	2074.053.016
	CH250/DH300/DH 350 32x38 UNI 8953	2074.053.003
	PH800/PH1250/MH1000 46x50 UNI 8953	2074.073.001
	PH800/PH1250/MH1000 46x50 UNI 8953	2074.083.001
EATON (CHAR-LYNN)	A-H-S ø 25	2074.012.012
	A-H-S ø 25.4	2074.012.014
	A-H-S SAE 1"6B	2074.013.013
EATON (CHAR-LYNN) SERIE 2000	BEARINGLESS	2074.013.033
	ø 31.75 CH7.96	2074.012.017
	ø 32 CH10	2074.012.019
	12/24 DP TH14	2074.013.038
	BEARINGLESS	2074.013.045
EATON (CHAR-LYNN) SERIE 4000	ø 40 CH12	2074.012.027
	ø 31.75 CH7.96	2074.012.020
	12/24 DP TH17	2074.013.016
	12/24 DP TH14	2074.013.038
EATON (CHAR-LYNN) SERIE 6000	ø 40 CH12	2074.012.027
EATON	MF-MV25 16/32 DP TH13	2074.013.001
	MF-MV25 16/32 DP TH15	2074.013.003
	MF-MV25 0 22.22 CH6.25	2074.012.001
	MF-MV (33/39/46) 16/32 DP TH21	2074.013.017
	MF-MV54 16/32 DP TH23	2074.013.018
	MF-MV (33/39/46/54) 12/24 DP TH14	2074.013.015
EATON (VICHERS)	25M 16/32 DP TH13	2074.013.001
	MVE-MFE19 16/32 DP TH15	2074.013.003
	35M-45M 12/24 DP TH14	2074.013.015
	35M-45M 0 31.75	2074.012.020
HAGGLUNDS ABEX DENISON	M1C/M4C/M45C 16/32 DP TH13	2074.013.001
	M3B/M3B1/TM3B 16/32 DP TH9	2074.013.010
	M4C/M45C 0 22.22 CH4/75	2074.012.003
	M3D/M1D/M4E/12/24 DP TH14	2074.013.015

	Tipo motore / Motor type	Codice / Code
INTERMOT	NHM 100/150 26x32 UNI 8953	2074.013.052
	NHM 700/800/900/1000/1100 46x50 UNI 8953	2074.053.020
	NHM 200/250/300 32x38 UNI 8953	2074.053.016
	NHM 400/450/500/600 36x42 UNI 8953	2074.053.017
	NHM 700/800/900/1000/1100 46x50 UNI 8953	2074.073.002
	NHM 700/800/900/1000/1100 46x50 UNI 8953	2074.083.002
	NHM 1400/1600/1800/2000 62x72 UNI 8953	2074.073.003
	NHM 1400/1600/1800/2000 62x72 UNI 8953	2074.083.003
	NHM 1400/1600/1800/2000 62x72 UNI 8953	2074.053.021
	NHM 1400/1600/1800/2000 62x72 UNI 8953	2074.053.021
LINDE	MF43M 16/32 DP TH15	2074.013.003
	MF63M 12/24 DP TH14	2074.013.015
	BMF35 25x22 DIN 5482 TH14	2074.013.070
	BMF50 30x27 DIN 5482 TH16	2074.013.060
	BMF 105 40x36 DIN 5482 TH20	2074.013.068
	BMF75 35x31 DIN 5482 TH18	2074.013.061
PARKER (VOLVO)	F11/10 (C-T) W20x1.25 DIN 5480 TH14	2074.013.046
	F11/19 (M-C-D) W25x1.25 DIN 5480 TH18	2074.013.068
	F12/40 (M-F-D) W32x2 DIN 5480 TH14	2074.013.020
	V11 (60/80) (M-S-S) 12/24 DP TH14	2074.013.015
	V12/60 (M-I-C) W30x2 DIN 5480 TH14	2074.013.019
	V12/60 (M-I-D) W35x2 DIN 5480 TH16	2074.013.021
	F11/10 (M-C-K) 0 20 CH6	2074.012.065
	F12/30 (M-F-Z) W25x1.25 DIN 5480 TH18	2074.013.062
	F11/39/58 (M-C-D) W30x2 DIN 5480 TH14	2074.013.030
	F12/80 (M-I-D) W40x2 DIN 5480 TH18	2074.013.064
	F11/78 (M-C-D) W40x2 DIN 5480 TH18	2074.013.065
	F11/110 (M-C-D) W40x2 DIN 5480 TH18	2074.013.034
F11/110 (M-C-D) W40x2 DIN 5480 TH18	2074.053.018	
V12-110 (U-S) S8/16 DP TH13	2074.053.005	
V12/110 (M-I-D) W45x2 DIN 5480 TH21	2074.053.006	
PARKER (TRW TOROMOTOR)	MF/MAC/MAF/MAB 0 25 CH8	2074.012.012
	MF/MAC/MAF/MAB 0 25.4 CH6.35	2074.013.014
	MF/MAC/MAF/MAB SAE 1"6B	2074.013.013
	MAB/MAE 0 31.75 CH7.96	2074.012.016
	ME 12/24 DP TH14	2074.013.047

Per una corretta scelta della predisposizione per motore idraulico contattare il Servizio Tecnico CHIARAVALLI.

For a correct choice of the input hydraulic motor adaptor, please contact CHIARAVALLI technical service.



	Tipo motore / Motor type	Codice / Code
REXROTH BOSCH GROUP (HYDROMATIK)	A2FM (10/12/16) W25x1.25 DIN 5480 TH18	2074.013.009
	A2FM (23/28/32) W25x1.25 DIN 5480 TH18	2074.013.062
	A2FM (23/28/32) W30x2 DIN 5480 TH14	2074.013.063
	A2FM (45/56) W30x2 DIN 5480 TH14	2074.013.019
	A2FM 45 W32x2 DIN 5480 TH14	2074.013.020
	A2FM (56/83) W35x2 DIN 5480 TH16	2074.013.021
	A2FM 80 W35x2 DIN 5480 TH16	2074.013.071
	A2FM (80/90) W40x2 DIN 5480 TH18	2074.013.064
	A2FM 107 W40x2 DIN 5480 TH18	2074.013.065
	A2FM 107 W40x2 DIN 5480 TH18	2074.053.007
	A2FM (107/125) W45x2 DIN 5480 TH21	2074.053.006
	A2FM 160 W45x2 DIN 5480 TH21	2074.053.009
	A2FM (160/180) W50x2 DIN 5480 TH24	2074.053.008
	A6VM55 W35x2 DIN 5480 TH16	2074.013.021
	A6VM55 W30x2 DIN 5480 TH14	2074.013.019
	A6VM80 W35x2 DIN 5480 TH16	2074.013.071
	A6VM80 W40x2 DIN 5480 TH18	2074.013.064
	A6VM107 W40x2 DIN 5480 TH18	2074.013.065
	A6VM107 W40x2 DIN 5480 TH18	2074.053.007
	A6VM107 W45x2 DIN 5480 TH21	2074.053.006
A6VM160 W45x2 DIN 5480 TH21	2074.053.009	
SAI	SAI M05 28x34 UNI 8953	2074.013.041
	SAI M05 35x2 DIN 5480 TH16	2074.013.044
	SAI M1 28x34 UNI 8953	2074.013.022
	SAI M1 35x2 DIN 5480 TH16	2074.013.040
	SAI M2 36x40 UNI 8953	2074.013.066
	SAI M2/M3 36x40 UNI 8953	2074.053.010
	SAI M4 56x65 UNI 8953	2074.053.025
SAE J744C	SAE A 16/32 DP TH9	2074.013.010
	SAE B 16/32 DP TH13	2074.013.001
	SAE BB 16/32 DP TH15	2074.013.003
	SAE C 12/24 DP TH14	2074.013.015
	SAE CC 12/24 DP TH17	2074.013.016
	SAE D 8/16 DP TH13	2074.053.005
STAFFA	HMC 030	2074.052.001

	Tipo motore / Motor type	Codice / Code	
SAMHYDRAULIC	AG/AR 0 25 CH8	2074.012.012	
	AG/AR 0 25.4 CH6.35	2074.012.014	
	AG/AR 0 25x22 DIN 5482 TH14	2074.013.011	
	AG/AR SAE 1"6B	2074.013.013	
	AGS/ARS 0 25 CH8	2074.012.026	
	AGS/ARS 0 32 CH10	2074.012.019	
	AGS/ARS SAE 1"6B	2074.013.012	
	HPR 0 32 CH10	2074.012.019	
	HPRC	2074.013.006	
	SAUER-DANFOSS (SAUER-SUNSTRAND)	90M032/042 16/32 DP TH13	2074.013.001
		90M032/042 16/32 DP TH15	2074.013.003
		90M055 16/32 DP TH21	2074.013.017
90M075/100 16/32 DP TH23		2074.013.018	
90M130 16/32 DP TH27		2074.053.012	
MMF025 16/32 DP TH13		2074.013.001	
MMF035/MMV035 16/32 DP TH15		2074.013.003	
MMF046/MMV046 16/32 DP TH13		2074.013.001	
MMF046/MMV046 16/32 DP TH15		2074.013.003	
51V060 (C6) 13/32 DP TH21		2074.013.017	
51V060 (S1) 12/24 DP TH14	2074.013.015		
51V080 (C7) 16/32 DP TH23	2074.013.018		
51V080 (S1) 12/24 DP TH14	2074.013.015		
51V110 (C8) 16/32 DP TH27	2074.053.012		
51V110 (F1) 8/16 DP TH13	2074.053.005		
OMF/SMF18 16/32 DP TH13	2074.013.001		
OMV/SMV 16/32 DP TH13	2074.013.067		
SMF2 (033/052/070) 16/32 DP TH21	2074.013.017		
SMF3 (049/066) 16/32 DP TH21	2074.013.017		
WHITE	HS-RS 0 25	2074.012.012	
	HS-RS 0 1"6B	2074.013.013	
	RE 0 32	2074.012.019	
	RE 0 31.75	2074.012.016	

Per una corretta scelta della predisposizione per motore idraulico contattare il Servizio Tecnico CHIARAVALLI.

For a correct choice of the input hydraulic motor adaptor, please contact CHIARAVALLI technical service.

FRENI IDRAULICI · HYDRAULIC BRAKES

I riduttori epicicloidali CHIARAVALLI possono essere dotati di freni idraulici.

Tali freni vengono adottati come **freni di stazionamento del riduttore e quindi idonei ad assolvere alla sola frenatura statica**. I freni hanno lubrificazione separata da quella del riduttore epicicloidale; prima della messa in servizio è quindi necessario provvedere al loro riempimento con idoneo olio idraulico.

Di seguito vengono riportate le caratteristiche principali dei freni idraulici disponibili:

T_{br} = Coppia frenante

p_{brMin} = Pressione minima di esercizio

p_{brMax} = Pressione massima di esercizio

CHIARAVALLI planetary gearboxes can be equipped with hydraulic brakes.

These brakes are used as **parking brakes for the gearbox, act to discharge a statics braking only**.

Brakes have separate lubrication from the planetary gearbox; before the start up, brakes need to be fulfilled by hydraulic oil.

Main characteristic for available hydraulic brakes are following:

T_{br} = Braking torque

p_{brMin} = Minimum operating pressure

p_{brMax} = Maximum operating pressure

T_{br} [Nm]	Applicabilità Applicability	p_{brMin} [bar]	p_{brMax} [bar]	 [I]		 Kg	Codice / Code
				Pos. di montaggio / Mount. position			
				V	B		
90		17	300	0.4	0.2	14	6074.000.500
140		23	300	0.4	0.2	14	6074.001.500
220		19	300	0.4	0.2	14	6074.002.500
250		22	300	0.6	0.3	21	5074.300.500
330		23	300	0.4	0.2	14	6074.003.500
400		35	300	0.6	0.3	21	5074.301.500
430		33	300	0.4	0.2	14	6074.004.500
550		39	300	0.4	0.2	14	6074.006.500
650		50	300	0.6	0.3	21	5074.302.500
800		38	300	0.6	0.3	21	5074.303.500
1000		45	300	0.6	0.3	21	5074.304.500
1250		45	300	0.6	0.3	21	5074.305.500
1500		45	300	0.6	0.3	21	5074.306.500
1700		50	300	0.6	0.3	21	5074.307.500

Applicabilità / Applicability				
Taglia / Size	CHPL		CHPLB	
	stadi / stage		stadi / stage	
1000	1-2-3-4	-	2-3-4	-
1600	1-2-3-4	-	2-3-4	-
2500	1-2-3-4	1	2-3-4	-
5000	1-2-3-4	1	2-3-4	-
7000	2-3-4	1-2	2-3-4	-
10000	2-3-4	1-2	2-3-4	-
16000	2-3-4	1-2	2-3-4	-
18000	3-4	2-3	3-4	2
25000	3-4	2-3	3-4	2
30000	3-4	2-3	3-4	-
35000	3-4	2-3	3-4	2-3

Per una corretta scelta del freno idraulico contattare il Servizio tecnico CHIARAVALLI.

For a correct choice of hydraulic brake, please contact CHIARAVALLI technical service.



CONDIZIONI GENERALI DI VENDITA

1) ORDINI - Gli ordini per materiale standard e speciale devono essere sempre riferiti alle offerte della CHIARAVALLI GROUP S.p.A. Le ordinazioni sono impegnative per il cliente. Una volta iniziata la lavorazione non si accettano annullamenti o riduzioni dell'ordine salvo il risarcimento da parte del cliente dei costi di materiale e di lavorazione sostenuti fino al momento della sospensione. La quantità spedita può variare del \pm 5% rispetto alla quantità ordinata.

2) PREZZI - Si intendono quelli in vigore alla data dell'ordine. Tutti i prezzi sono per merce resa franco Premezzo, imballo escluso. Qualora nel corso della fornitura si verificassero aumenti nel materiale o negli altri costi di produzione è facoltà della CHIARAVALLI GROUP S.p.A. di adeguare i prezzi, anche per gli ordini in corso, agli aumenti verificatisi.

3) TERMINI DI CONSEGNA - Sono da considerarsi validi solo i termini di consegna indicati dalla CHIARAVALLI GROUP S.p.A. Essi sono da considerarsi comunque solo indicativi. Nei casi di difficoltà nell'approvvigionamento dei materiali, di sciopero o comunque in tutti i casi di forza maggiore, i termini di consegna vengono automaticamente prorogati senza che la CHIARAVALLI GROUP S.p.A. sia tenuta a corrispondere indennizzi di sorta. Il cliente ha in ogni caso l'obbligo del ritiro del materiale speciale ordinato all'approntamento.

4) SPEDIZIONI - Le spedizioni si intendono a carico del committente ed eseguite a suo rischio e pericolo. I reclami per gli eventuali ammanchi devono presentarsi entro 8 gg. dal ricevimento della merce. Qualora venga pattuito che il costo del trasporto sia a carico, anche solo in parte, della CHIARAVALLI GROUP S.p.A., questa si riserva il diritto di scegliere il mezzo di spedizione più economico.

5) IMBALLO - L'imballo è fatturato al prezzo di costo.

6) RESI - Non si accettano ritorni di merce per qualsiasi causa se non preventivamente autorizzati e con imballi, eventuale sdoganamento e resa a totale carico dell'acquirente. A copertura degli oneri di magazzino ed amministrativi sarà emessa nota di addebito in ragione del 15% del valore della merce resa.

7) GARANZIA - La ditta CHIARAVALLI GROUP S.p.A. si impegna a riparare o sostituire gratuitamente quei pezzi da essa riconosciuti difettosi. La merce contestata dev'essere resa alla sede della CHIARAVALLI GROUP S.p.A., franco di ogni spesa. La garanzia decade qualora i pezzi resi come difettosi siano stati riparati o manomessi. Le riparazioni di pezzi difettosi eseguite dal committente saranno riconosciute solamente dietro autorizzazione dalla CHIARAVALLI GROUP S.p.A. e dopo approvazione di essa del preventivo di spesa. La CHIARAVALLI GROUP S.p.A. non assume responsabilità né riconosce indennizzi di sorta per danni che si verificassero durante l'impiego dei suoi prodotti anche se difettosi. Non viene riconosciuta la garanzia per perdita di lubrificante determinata da normale usura degli anelli di tenuta.

8) RESPONSABILITÀ - La ditta CHIARAVALLI GROUP S.p.A. non assume responsabilità né riconosce indennizzi di sorta per danni che si verificassero durante l'impiego dei suoi prodotti anche se difettosi. La CHIARAVALLI GROUP S.p.A. declina ogni responsabilità nell'esecuzione di particolari su disegno del cliente sottostanti ad eventuali brevetti.

9) PAGAMENTI - Saranno riconosciuti validi solo i pagamenti effettuati nei modi e nei termini pattuiti. Trascorso il termine di pagamento la CHIARAVALLI GROUP S.p.A. conteggerà gli interessi di mora al tasso del 3% superiore a quello legale, fermo il diritto di esigere il pagamento. In caso di ritardato o mancato pagamento da parte del committente la ditta CHIARAVALLI GROUP S.p.A. si riserva il diritto di sospendere le consegne degli ordini in corso o di pretendere il pagamento anticipato senza riconoscere al committente indennizzi di sorta o risarcimenti. Qualsiasi contestazione dei materiali in corso di fabbricazione o già in possesso del committente non libera quest'ultimo dall'effettuare il pagamento alla scadenza stabilita e per l'intero ammontare della fattura senza alcuna detrazione.

10) PROPRIETÀ - Tutta la merce spedita rimane sempre di proprietà della Ditta CHIARAVALLI GROUP S.p.A. fino al pagamento completo delle sue fatture.

11) FORO COMPETENTE - Qualsiasi controversia inerente ai rapporti commerciali con la CHIARAVALLI GROUP S.p.A. sarà di competenza del Tribunale di Busto Arsizio.

1) ORDERS - Orders for special and standard material must always refer to offers made by CHIARAVALLI GROUP S.p.A. The orders are binding for the client. Once work has commenced no cancellations or order reductions will be accepted unless the client reimburses the costs of the material and the work carried out up to the moment in which the order was suspended. The quantity despatched can vary by \pm 5% compared to the quantity ordered.

2) PRICES - The prices are those in force at the date of order. All prices are for goods delivered ex-works Premezzo, packing excluded. If there should be any increase in production and material costs over the duration of the supply, CHIARAVALLI GROUP S.p.A. reserves the right to adapt the prices accordingly, even for orders in course.

3) TERMS OF DELIVERY - Only the terms of delivery indicated by CHIARAVALLI GROUP SpA are to be considered valid. However, they must only be considered as indicative. In the event of difficulty in the procurement of materials, strikes or in any event in all cases of force majeure, the terms of delivery will be automatically extended without CHIARAVALLI GROUP S.p.A. having to pay any reimbursement for damages. The client is obligated to collect special material ordered when ready.

4) DELIVERIES - Deliveries are the responsibility of the purchaser and are carried out at his own risk and peril. Any claims for shortages must be presented within 8 days of receipt of the goods. If it is agreed that the cost of transport is to be paid, even if only in part, by CHIARAVALLI GROUP S.p.A., the latter reserves the right to choose the most economical means of transport.

5) PACKING - Packing will be invoiced at cost.

6) RETURNS - No returns for any reason will be accepted unless previously authorised and with packing, any customs clearance and the return paid for by the purchaser. To cover warehouse and administrative expenses a debit note will be issued for approx. 15% of the value of the goods returned.

7) WARRANTY - CHIARAVALLI GROUP S.p.A. promises to repair or substitute free of charge any parts that they recognise as being defective. The questioned goods must be returned to the factory of CHIARAVALLI GROUP S.p.A., free of all expenses. The warranty will be considered cancelled in the event that the parts returned as defective have been repaired or tampered with. The repair of defective parts carried out by the purchaser will only be accepted after authorisation from CHIARAVALLI GROUP S.p.A. and after their approval of the cost estimate. CHIARAVALLI GROUP S.p.A. does not accept responsibility or pay any reimbursement for damages that occur during the use of their products, even if defective. Warranty is excluded for leakage of lubricant caused by wear of the oil seals.

8) RESPONSIBILITY - CHIARAVALLI GROUP S.p.A. does not accept responsibility or pay any reimbursement for damages that occur during the use of their products, even if defective. CHIARAVALLI GROUP S.p.A. declines all responsibility in the execution of parts to a client's design under any patents.

9) PAYMENTS - Only payments carried out in the manner and terms agreed will be considered valid. Once the due date of payment has passed, CHIARAVALLI GROUP S.p.A. will calculate the interest on delayed payment at a rate that is 3% higher than the legal one, retaining the right to demand payment. In the event of delayed or missing payment by the purchaser, the company CHIARAVALLI GROUP S.p.A. reserves the right to suspend deliveries of the orders in course or to demand advance payment without having to pay any reimbursement or compensation to the purchaser. Any dispute regarding materials in manufacture or already possessed by the purchaser does not free the latter from the commitment of making the payment by the agreed date and for the whole amount of the invoice without making any deductions.

10) OWNERSHIP - All of the goods despatched remain the property of CHIARAVALLI GROUP S.p.A. until the invoice is fully paid.

11) COMPETENT COURT - Any controversy concerning business relations with CHIARAVALLI GROUP SpA will be dealt with under the jurisdiction of the Court of Busto Arsizio.

Chiaravalli Group S.p.A. declina qualsiasi responsabilità per eventuali errori in cui possa essere incorsa nella compilazione del presente catalogo e si riserva il diritto di apporre al disegno ed alle dimensioni dei prodotti elencati qualunque modifica richiesta da esigenze di costruzione o dallo sviluppo evolutivo del prodotto.

CHIARAVALLI GROUP SpA, do not accepts responsibility for any errors in the production of this catalogue and reserves the right to add to the drawings designs of the listed products any modification request by manufacturing requirements or due to evolution of the products.



CHIARAVALLI Cz a.s.
Průmyslová 2083
59401 Velké Meziříčí
Česká republika
Tel. +420 566 502 030
www.chiaravalli.cz



CHIARAVALLI POLSKA Sp. z o. o.
ul. Polna 133
87 - 100 Toruń
Polska
Tel. + 48 56 623 30 00
www.chiaravalli.pl



Via per Cedrate, 476
21044 Cavarina con Premezzo (VA)
Italy
Tel. +39 0331 214 511
Fax +39 0331 218 175
www.chiaravalli.com
chiaravalli@chiaravalli.com



Localizzazione satellitare: coordinate N 45° 41.394 · E8° 48.726